



SB-10058788-9690

Service Bulletin

Bulletin No.: 15356
Date: August 2015

SPECIAL COVERAGE

SUBJECT: Special Coverage Adjustment – Loss of Electric Power Steering Assist

**MODELS: 2007-2012 Chevrolet Malibu
2007-2010 Pontiac G6
2007-2010 Saturn AURA
Equipped with Electric Power Steering Assist (EPS)**

CONDITION

On some 2007-2012 model year Chevrolet Malibu, Pontiac G6, and Saturn AURA vehicles equipped with electric power steering assist (EPS), the steering column torque sensor or the EPS motor/controller may cause the vehicle to suddenly lose EPS. If the vehicle loses EPS, the vehicle's driver information center will display a warning message and a warning chime will be heard. The vehicle will revert to a manual steering mode, which requires greater driver effort to operate at low vehicle speeds.

SPECIAL COVERAGE ADJUSTMENT

This special coverage covers the condition described above for a period of 10 years or 150,000 miles (240,000 km), whichever occurs first, from the date the vehicle was originally placed in service, regardless of ownership.

Dealers are to replace the steering column torque sensor or EPS motor/controller based on DTC. The repairs will be made at no charge to the customer.

For vehicles covered by Vehicle Service Contracts, all eligible claims with repair orders on or after August 28, 2015, are covered by this special coverage and must be submitted using the labor operation codes provided with this bulletin. Claims with repair orders prior to August 28, 2015, must be submitted to the Service Contract provider.

VEHICLES INVOLVED

All involved vehicles are identified by Vehicle Identification Number on the Applicable Warranties section in GM Global Warranty Management system. Dealership service personnel should always check this site to confirm vehicle involvement prior to beginning any required inspections and/or repairs. It is important to routinely use this tool to verify eligibility because not all similar vehicles may be involved regardless of description or option content.

PART INFORMATION

Parts required to complete this recall are to be obtained from General Motors Customer Care and Aftersales (GMCCA). Please refer to your “involved vehicles listing” before ordering parts. Normal orders should be placed on a DRO = Daily Replenishment Order. In an emergency situation, parts should be ordered on a CSO = Customer Special Order.

Part Number	Description	Quantity/Vehicle
23232310	SENSOR KIT – STRG SHAFT TORQUE	1
22837369	MODULE, ELEK P/S MOT CONT	1

SPECIAL TOOLS

For countries / regions with vehicles involved in Recall 14116 (OCT2014), J-45126 (snap ring pliers) and GE-45126-5 (snap ring plier adapters) were previously distributed / used. These tools are also required for the repair outlined in this Service Procedure. To order J-45126 & GE-45126-5, contact your local GM / Bosch Special Tool distributor. The GM / Bosch Tool distributor will provide either J-45126 or OTC 4513 (snap ring pliers). A valid vehicle identification number (VIN) is required to order the tool. The tools are being provided to dealers at no-charge. The shipping cost of the tool is covered as a net item expense. This field action bulletin provides ONE free campaign tool per dealer. Additional tools must be purchased. Contact your local Bosch Sales Representative or your GM Special Tools website.

SERVICE PROCEDURE

1. Verify that the Steering Shaft Torque Sensor requires replacement. Refer to the appropriate diagnostic information in SI.

- If the Steering Shaft Torque Sensor requires replacement, replace Steering Shaft Torque Sensor. Refer to *Steering Shaft Torque Sensor Replacement* in SI.

Note: Carefully read and follow the important steering shaft torque sensor replacement tips below:

- Review the steering shaft torque sensor replacement video BEFORE completing the repair.
 - **For U.S.:** A video that demonstrates the steering shaft torque sensor replacement can be viewed at www.centerlearning.com (or use the link on Global Connect). Select "Resources" then "Video On Demand". The VOD portal will open. Select GM STC from the choices on the left. Search for 10214.07D. This will bring up the July 2014 Emerging Issues Seminar. The video is part of this seminar. Click on the thumbnail to launch the video.
 - **For Canada:** A video that demonstrates the steering shaft torque sensor replacement can be viewed on the GM Centre of Learning (LMS) web site which can be accessed via the Single Sign-on process through Global Connect. Click on the “Resources” menu option, and then select “Video on Demand,” “GM Pro – Centre of Learning” and “Service Technical.” The video will be in the list displayed on the page.
- Refer to *Steering Shaft Torque Sensor Replacement* in SI to review the service procedure. Follow the procedure as written to ensure a successful repair. The service procedure is updated often. To ensure that you are using the most current information, refer to SI BEFORE completing the procedure.
- Before starting the repair procedure, slightly turn the wheel in both directions to remove any load (torque).

- The new sensor should be handled with care while it is being prepared for installation.
 - The alignment pin should be centered during all of the installation steps and must not be removed until the new sensor is fully installed and aligned. It is very important to follow the alignment pin removal instructions included in the SI procedure.
 - It is critical to use the supplied alignment tool before, during and after the installation of the new sensor.
 - Before starting the calibration process, TURN ON the ignition with engine OFF and remove hands or any other objects from steering wheel to avoid any load (torque). Repeat step if needed. Cycle the ignition OFF then turn it ON.
2. Remove the steering shaft torque sensor. Refer to *Steering Shaft Torque Sensor Replacement* in SI.
 3. Install a new steering shaft torque sensor. Refer to *Steering Shaft Torque Sensor Replacement* in SI.

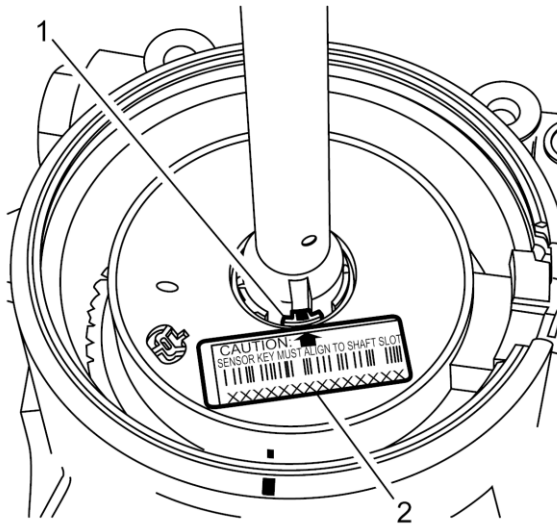

3824308

4. Document the last 9 digits of the NEW steering shaft torque sensor on the vehicle repair order. The serial number is located on the bottom of the caution label (2).
5. If necessary, remove the power steering assist motor. Refer to *Power Steering Assist Motor Replacement* in SI.
6. If necessary, install a new power steering assist motor. Refer to *Power Steering Assist Motor Replacement* in SI.

CUSTOMER REIMBURSEMENT - For US

Customer requests for reimbursement of previously paid repairs to correct the condition described in this bulletin are to be submitted to the dealer by September 30, 2016, unless otherwise specified by state law. If this is not convenient for the customer, the customer may mail the completed Customer Reimbursement Request Form and all required documents to the GM Customer Assistance Center. Repairs must have occurred within the 10 years of the date the vehicle was originally placed in service, or 150,000 miles, whichever occurs first.

All reasonable and customary costs to correct the condition described in this bulletin should be considered for reimbursement. Any questions or concerns should be reviewed with your GM representative prior to processing the request.

When a customer requests reimbursement, they must provide the following:

- A completed Customer Reimbursement Request Form. This form is mailed to the customer or can be obtained through GM GlobalConnect.
- The name and address of the person who paid for the repair.
- Paid receipt confirming the amount of the repair expense, a description of the repair, and the person or entity performing the repair.

IMPORTANT: GM requires dealers to approve or deny a reimbursement request within 30 days of receipt. If a reimbursement request is approved, the dealer should immediately issue a check to the customer and submit an appropriate warranty transaction for the incurred expense. If a reimbursement request is denied, the dealer MUST provide the customer with a clear and concise explanation, in writing, as to why the request was denied. The bottom portion of the Customer Reimbursement Request Form may be used for this purpose. If the denial was due to missing documents, the customer can resubmit the request when the missing documents are obtained, as long as it is still within the allowed reimbursement period.

Warranty transactions for customer reimbursement of previously paid repairs are to be submitted as required by GM Global Warranty Management. Additional information can also be found in Warranty Administration Bulletin 11-00-89-004.

CUSTOMER REIMBURSEMENT - For Canada and Export

Customer requests for reimbursement of previously paid repairs to correct the condition described in this bulletin are to be submitted to the dealer prior to or by September 30, 2016. Repairs must have occurred within the 10 years of the date the vehicle was originally placed in service, or 240,000 kilometers, whichever occurs first.

When a customer requests reimbursement, they must provide the following:

- Proof of ownership at time of repair.
- Original paid receipt confirming the amount of unreimbursed repair expense(s) (including Service Contract deductibles), a description of the repair, and the person or entity performing the repair.

All reasonable and customary costs to correct the condition described in this bulletin should be considered for reimbursement. Any questions or concerns should be reviewed with your GM representative prior to processing the request.

WARRANTY TRANSACTION INFORMATION

Submit a transaction using the table below. All transactions should be submitted as a ZREG transaction type, unless noted otherwise.

For Use With Vehicles <u>Still Covered</u> Under Applicable New Vehicle Limited Warranties			
Labor Code	Description	Labor Time	Net Item
7429949	Steering - Customer Concern Not Duplicated (CCND)	0.3	N/A
7441770	Replace Steering Shaft Torque Sensor* Add: Adjustable Foot Pedals	1.5 0.3	N/A
7480158	Steering Shaft Torque Sensor and Power Steering Assist Motor Replacement* Add: With Adjustable Foot Pedals	2.1 0.3	N/A
7420270	Power Steering Assist Motor Replacement	0.6	N/A

Note: For reimbursements on vehicles covered under warranty, refer to the Policies and Procedures Manual.

For Use With Vehicles <u>No Longer Covered</u> Under Applicable New Vehicle Limited Warranties			
Labor Code	Description	Labor Time	Net Item
9900228	Steering - Customer Concern Not Duplicated (CCND)	0.3	N/A
9900229	Replace Steering Shaft Torque Sensor* Add: With Adjustable Foot Pedals	1.5 0.3	N/A
9900231	Steering Shaft Torque Sensor and Power Steering Assist Motor Replacement* Add: With Adjustable Foot Pedals	2.1 0.3	N/A
9900230	Power Steering Assist Motor Replacement	0.6	N/A
9900232	Customer Reimbursement Approved	0.2	**
9900233	Customer Reimbursement Denied - For US dealers only	0.1	N/A

* To prevent a rejection of the warranty transaction, the last 9 digits of the NEW steering shaft torque sensor, which was recorded on the vehicle repair order, MUST be entered when submitting the warranty transaction.

** The amount identified in "Net Item" should represent the dollar amount reimbursed to the customer.

Note: To avoid having to "H" route the customer reimbursement transaction for approval, it must be submitted prior to the repair transaction.

Note: Customer reimbursement will not close this recall. The service procedure must also be performed on the vehicle.

CUSTOMER NOTIFICATION

General Motors will notify customers of this special coverage on their vehicles (see copy of typical customer letter included with this bulletin - actual divisional letter may vary slightly).



September 2015

This notice applies to your vehicle, **VIN:** _____

Dear General Motors Customer:

As the owner of a 2007-2012 model year Chevrolet Malibu, 2007-2010 model year Pontiac G6, or 2007-2010 model year Saturn AURA, your satisfaction with our product is very important to us.

This letter is intended to make you aware that on some 2007-2012 model year Chevrolet Malibu, 2007-2010 model year Pontiac G6, or 2007-2010 model year Saturn AURA vehicles equipped with electric power steering assist (EPS), the steering column torque sensor or the EPS motor/controller may cause the vehicle to suddenly lose EPS. If your vehicle loses EPS, your vehicle's driver information center will display a warning message and you will hear a warning chime. The vehicle will revert to a manual steering mode, which requires greater driver effort to operate at low vehicle speeds.

Do not take your vehicle to your GM dealer as a result of this letter unless you believe that your vehicle has the condition as described above.

What We Have Done: General Motors is providing owners with additional protection for the condition described above. If this condition occurs on your 2007-2012 model year Chevrolet Malibu, 2007-2010 model year Pontiac G6, or 2007-2010 model year Saturn AURA within 10 years of the date your vehicle was originally placed in service or 150,000 miles (240,000 km), whichever occurs first, the condition will be repaired for you at **no charge**. Diagnosis or repair for conditions other than the condition described above is not covered under this special coverage program.

What You Should Do: If you believe that your vehicle has the condition described above, repairs and adjustments qualifying under this special coverage must be performed by a General Motors dealer. You may want to contact your GM dealer to find out how long they will need to have your vehicle so that you may schedule the appointment at a time that is convenient for you. Keep this letter with your other important glove box literature for future reference.

Reimbursement: If you have paid for repairs for the condition described in this letter, please complete the enclosed reimbursement form and present it to your dealer with all required documents. Working with your dealer will expedite your request, however, if this is not convenient, you may mail the completed reimbursement form and all required documents to Reimbursement Department, PO Box 33170, Detroit, MI 48232-5170. The completed form and required documents must be presented to your dealer or received by the Reimbursement Department by September 30, 2016, unless state law specifies a longer reimbursement period.

If you have any questions or need any assistance, just contact your dealer or the appropriate Customer Assistance Center at the number listed below.

Division	Number	Text Telephones (TTY)
Chevrolet	1-800-222-1020	1-800-833-2438
Pontiac	1-800-762-2737	1-800-833-7668
Saturn	1-800-553-6000	1-800-833-6000
Guam	65-6267-1752	
Puerto Rico – English	1-800-496-9992	
Puerto Rico – Español	1-800-496-9993	
Virgin Islands	1-800-496-9994	

We are sorry for any inconvenience you may experience; however, we have taken this action in the interest of your continued satisfaction with our products.

Terry M. Inch
Executive Director
Global Connected Customer Experience

Enclosure
15356