

# SAFETY RECALL

Volvo Trucks North America  
Greensboro, NC USA

**VOLVO**

---

Date	Number	Release	Page
10.2015	<b>RVXX1504</b>	<b>01</b>	1 (11)

## Trailer Hand Brake Trim Panel, Replacement

**VN**

### SAFETY RECALL INFORMATION:

(October 2015)

VOLVO Trucks North America has determined there is a defect related to the trailer hand brake trim panel in certain VOLVO VN trucks manufactured between 05/31/2011 and 12/01/2014. The cut out in the trailer hand brake trim panel may restrict the trailer hand brake handle from returning to the off position. Therefore, the trailer service brakes could drag, which may cause a wheel end to overheat, a potential wheel end fire, or tire blowout. An inspection and/or replacement of the current trim panel may be necessary to prevent a wheel end from overheating, a potential wheel end fire, or tire blowout. Follow the repair procedure outlined in this Safety Recall.

VOLVO has received no reports of wheel end fires or tire blowouts as a result of this condition. Therefore, VOLVO considers this as a proactive measure to protect the public and VOLVO's customers from the potential risk associated with this defect.

### VEHICLES AFFECTED:

Certain VOLVO VN model trucks manufactured from May 31, 2011 through December 01, 2014.

### VEHICLE IDENTIFICATION NUMBERS (VIN):

The number of vehicles affected by this recall is 2863 (2854 USA, and 9 Canada).

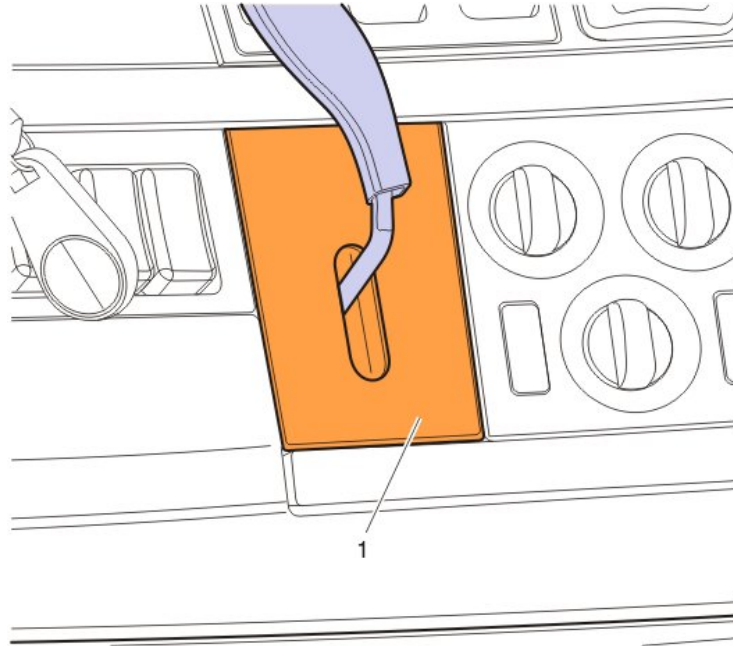

**Required Parts:**

To schedule parts orders and repairs, please call (877) 986-5862 with the Vehicle Identification Number (VIN) of the vehicle in need of this repair.

Trailer Hand Brake Trim Panel, Replacement Parts			
Item	Description	Part Number	Qty
1	Trim Panel, Trailer Brake	84708234	1

**Decommissioning the Truck for Inspection or Repair:**

1. Secure the vehicle for service by parking on a flat and level surface, placing the transmission in neutral, applying the parking brake, turning the ignition key to the OFF position, and chocking the front wheels.

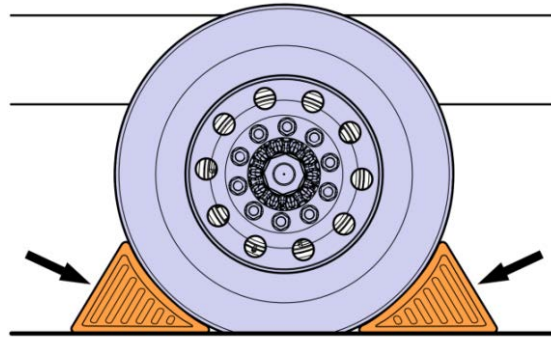

2. Disconnect the cable from the battery's negative (ground) terminal.

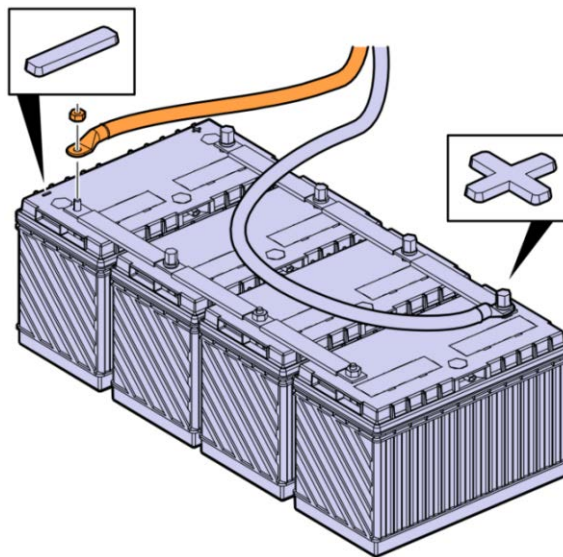

### Trailer Hand Brake Trim Panel, Replacement Procedure:

NOTE
The Illustrations shown in this document are used for reference only and may differ slightly from the actual vehicle being serviced. However, the replacement procedure is represented as accurately as possible.

1. Using a caliper, measure the length of slot surrounding the trailer hand brake in the trim panel to determine if replacement of the trim panel is necessary. If trim panel replacement is necessary, proceed to step 2.

NOTE
If the slot in the trim panel is less than 59.0 mm (2.3 in), replace the trailer hand brake trim panel with trim panel (part number 84708234).

NOTE
If the slot in the trim panel is greater than 59.0 mm (2.3 in), proceed to <b>Commissioning the Truck for Operation</b> section.

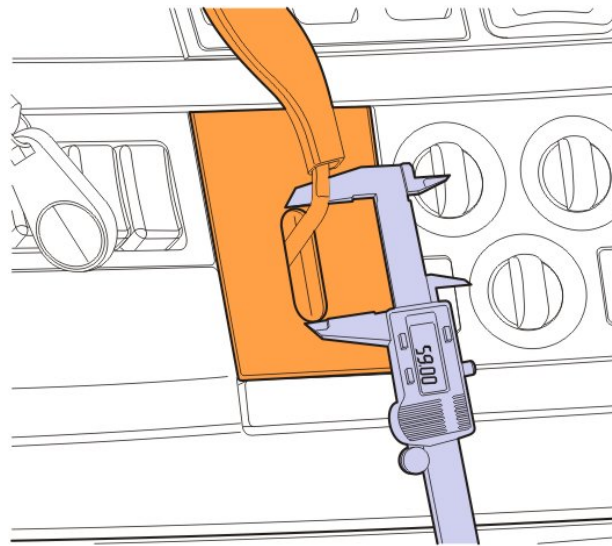

2. Open the cup holder.
3. Remove the panel screws.
4. Remove the fuse relay cover/cup holder.

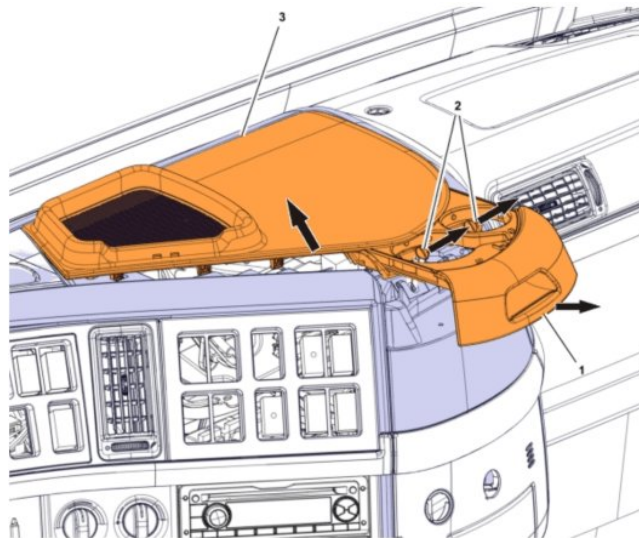

5. Remove the lower dash panel as shown in the figure below.

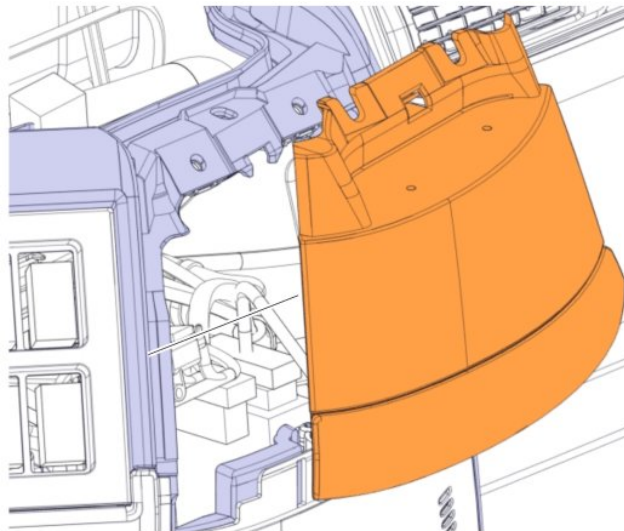

6. Remove the trailer hand brake knob.



7. Remove trim sections shown below and store installation.

**NOTE**

Take care not to damage the trim sections. Remove the trim sections starting from the left side to the right side to prevent damage to the trim retention tabs.

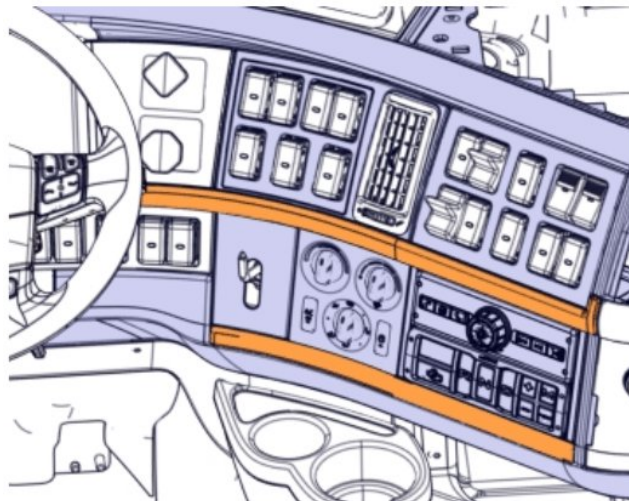

8. Grasp the trailer hand brake trim panel by the top, pull, lift up, and out.

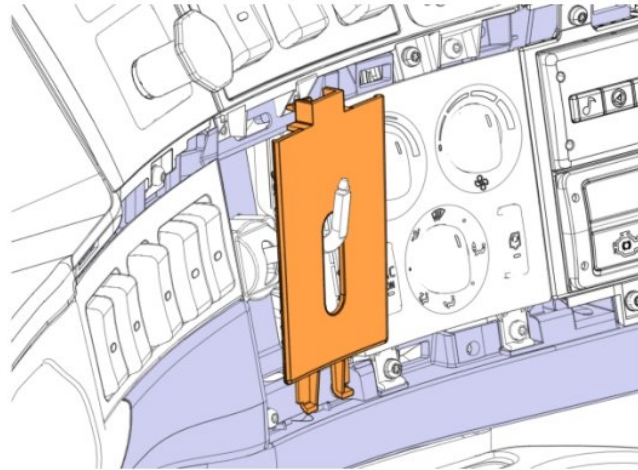

9. Install the replacement trailer brake trim panel.

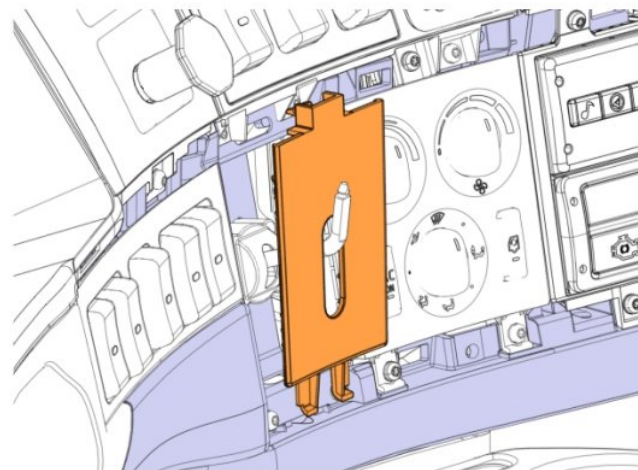

10. Install the previously removed trim sections.

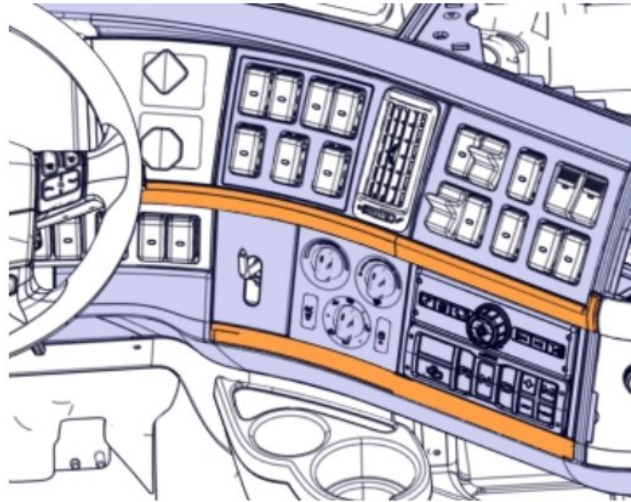

11. Install the trailer hand brake knob.





12. Install the lower dash panel.

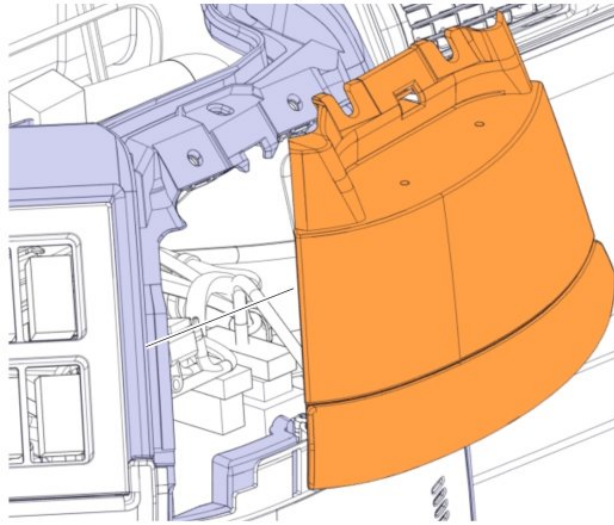

13. Install the previously removed fuse relay cover/cup holder.

14. Install the fasteners securing the fuse relay cover/cup holder.

15. Tighten the fasteners to  $3.4 \pm 0.6$  Nm ( $30 \pm 5$  in-lb).

16. Close the cup holder.

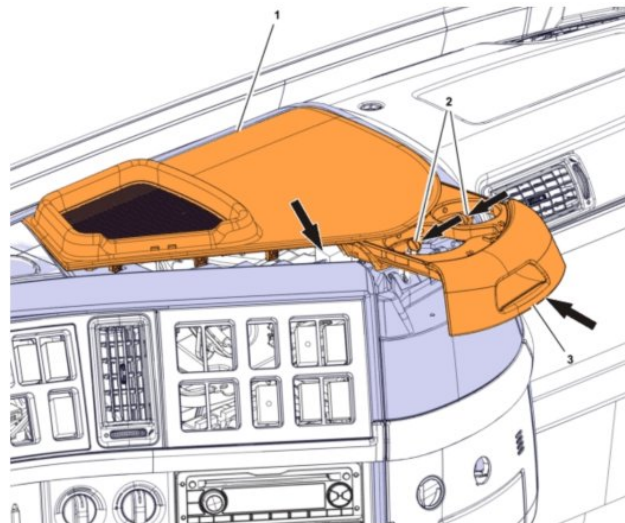

### Commissioning the Truck for Operation:

1. Connect the battery cable to the negative (ground) terminal.

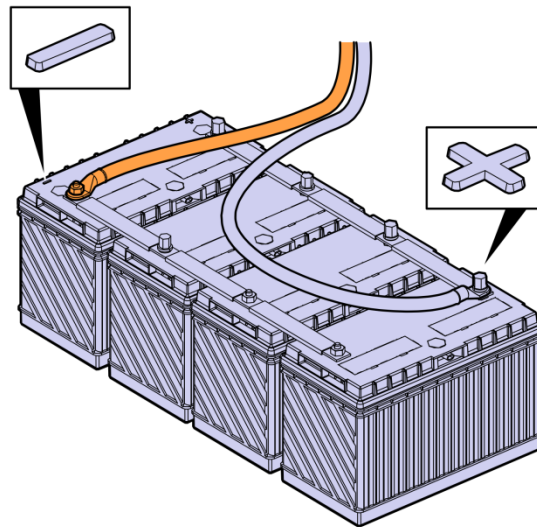

2. Remove the wheel chocks.

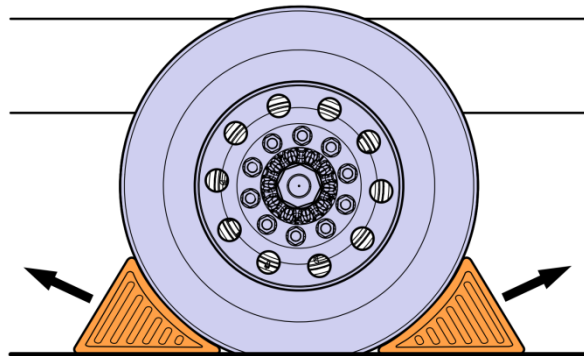

**Reimbursement:**

<b>This repair is covered by an authorized Safety Recall campaign. Reimbursement is obtained through the normal claim handling process.</b>		
	<b>UCHP Reimbursement</b>	<b>eWarranty Reimbursement</b>
<b>Claim Type</b> (used only when uploading from the Dealer Business System)	R	R
<b>Recall Status</b>		
Vehicle repaired per instructions		1-Modified per instructions
<b>Labor Code</b>		
Primary Labor Code (Trailer Hand Brake Trim Panel, Replacement)	8810-03-09-01 0.3 hrs	81724-0-01 0.3 hrs
Time to take charge of vehicle and determine campaign status	1700-16-01-01 0.3 hrs	17003-0-01 0.3 hrs
<b>Causal Part</b>	3175583	3175583
<b>Authorization Number</b>	C6560	RVXX1504

Take-charge time is not included in the labor code for this operation. Take charge may be eligible, but can only be used once per vehicle repair visit. If the vehicle is having other warranty repairs performed, take-charge should be charged to the warranty repair, otherwise take-charge can be charged to this Safety Recall campaign.