



MERCEDES-BENZ USA, LLC
303 Perimeter Center North, Suite 202
Atlanta, GA, 30346
Phone: (770) 705-0600
Fax: (770) 705-0117
MBUSA.com

Service

newschannel update

TO: Mercedes-Benz Dealer Principals, General Managers, Sales Managers, Service Managers, Parts Managers	FROM: Thomas Brunner, Department Manager, Vehicle Compliance and Analysis, Engineering Services
RE: Recall Campaign 2016 100004 MY 2016-2017 Model 217 (S-Class Coupe/Cabriolet) Base Headlamp Adjustment	DATE: November 23, 2016

IMPORTANT RECALL LAUNCH INFORMATION

Please see the attached document for the subject new recall campaign.





RECALL CAMPAIGN LAUNCH NOTIFICATION

November 23, 2016

Campaign No. :	Base Headlight Adjustment
2016 100004	
<p>This is to notify you of the launch of a Recall Campaign to check the low beam headlamps and repair as necessary on 1004 MY16-17 S-Class Coupe, Cabriolet (217) vehicles. Please review the recall information below. The recall will be launched on November 23, 2016 and all affected VINs will be flagged in VMI.</p>	
Background	
Issue	This Recall Campaign has been initiated because Daimler AG ('DAG'), the manufacturer of Mercedes-Benz vehicles has determined that on certain S-Class Coupe, Cabriolet vehicles, the low-beam headlamps were not adjusted to specifications due to production changes at the supplier. Illumination of the low-beam headlamps may not meet predefined legal requirements.
What We're Doing	MBUSA will conduct a voluntary recall. An authorized Mercedes-Benz Dealer will check and recalibrate the headlamps on the affected vehicles as necessary.
Vehicles Affected	
Vehicle Model Year	Model Year 2016-2017
Vehicle Model	S-Class Coupe, Cabriolet (S550, S550 4Matic, S63 AMG 4Matic, S65 AMG)
Vehicle Populations	
Total Recall Population	1004
Total Vehicles in Dealer Inventory	82 (AOMs will forward the VIN list of vehicles in dealer inventory)
<p>Given this notice, it is a violation of Federal law for a dealer to sell or lease any <u>new</u> Model Year 2016 S-Class covered by this notification in dealer inventory until the vehicle has been repaired.</p> <p>Dealers are advised to check <u>new</u> vehicle inventory for recall campaign applicability in VMI, and repair immediately. Once the repair is complete, the vehicle may be sold or leased.</p>	
Dealer Notification (NCU)	
Documentation pertaining to this recall will be received by dealers in NetStar and Star TekInfo on the following date:	November 23, 2016
Next Steps/Notes	
Owner notification letter timeline	Customer notification letters will be mailed on Friday, December 2, 2016.
AOMS/SOMS	AOMs – If your name is copied on this email, you may have a dealer that has a vehicle affected by this recall in inventory.
<p>While we regret any inconvenience this may cause, MBUSA is determined to maintain a high level of vehicle quality and customer satisfaction. Please refer all customer inquiries to the Customer Assistance Center at 1-800-FOR-MERCEDES. Please contact Allen Ambulo (x2579) or me with any questions.</p>	



Mercedes-Benz

Campaign No. 2016100004, November 2016

TO: ALL MERCEDES-BENZ CENTERS

SUBJECT: **Model 217, Model Years 2016 and 2017**
Check Left and Right Base Light in Low Beam Headlamp and Correct if Necessary

Daimler AG ('DAG'), the manufacturer of Mercedes-Benz vehicles has determined that on certain S-Class Coupe/Cabriolet (217 platform) vehicles, the base-light in the low-beam headlamp may not be adjusted according to specification and may deviate from the tolerance range required by Federal Motor Vehicle Safety Standard 108. A misaimed headlamp may not provide the optimal road illumination at night, and could increase the risk of a crash. An authorized Mercedes-Benz dealer will first check the base setting of the headlamps on the affected vehicles and correct it, if necessary.

Prior to performing this Recall Campaign:

- Please check VMI to determine if the vehicle is involved in the Campaign and if it has been previously repaired.
- Please review the entire Recall Campaign bulletin and follow the repair procedure exactly as described.

Please note that Recall Campaigns **do not expire** and may also be performed on a vehicle with a vehicle status indicator.

Approximately 1,004 vehicles are involved.

Order No. P-RC-2016100004

This bulletin has been created and maintained in accordance with MBUSA-SLP S423QH001, Document and Data Control, and MBUSA-SLP S424HH001, Control of Quality Records.

Procedure

A. Check Level of Right and Left Low Beams

1. Connect diagnostic system (XENTRY/DAS) and select "move to calibrated vehicle level (automatic)": Control units view → Chassis → ADS → Adaptive damping system → Actuators → Move to calibrated vehicle level (automatic). Follow on-screen instructions.
2.  Check level of right and left low beam; refer to WIS: AH82.10-P-1000-01A for general information on checking/correcting headlamp adjustment.

Equipment Note:

Deviating from the headlamp aimers specified in the above WIS instructions, the level of the low beams can be adjusted using a **current approved - required headlamp aimer**.

Note:

The side adjustment reference line (4, Figure 1) must pass through the central marking (3) of the height adjustment reference line (2).

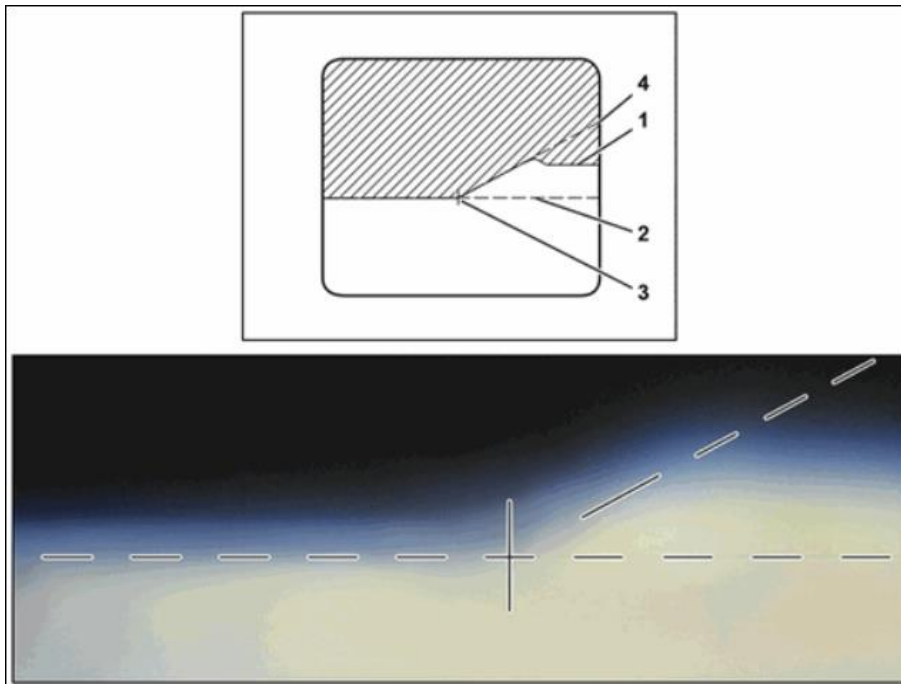

Figure 1

- If level of right and left low beams is correct (**OK**), Procedure is complete.
- If level of **right** low beams is **not** correct (**NOT OK**): Proceed to **Subject B**.
- If level of **left** low beams is **not** correct (**NOT OK**): Proceed to **Subject C**.

Note:

Record findings on repair order.

B. Adjust Right Low Beam and Headlamp Base Light

i Note:

Do **NOT** remove anti-tamper devices (lead seals).



1.  Remove right engine compartment cover (1, Figure 2).



Figure 2 (left cover shown)



Figure 3

2.  Remove heat exchanger (circled, Figure 4) from washer fluid reservoir (3, Figure 3) and place to one side with lines connected.
3.  Unfasten engine coolant reservoir (2, Figure 3) and washer fluid reservoir (3) and place to one side **with lines connected** (Figures 3 to 6). Refer also to WIS: AR20.30-P-4950LF (steps 1, 5, 8) and AR82.35-P-6000LF (step 12).

i Note:

- The engine coolant reservoir and the windshield washer reservoir do **NOT** have to be removed completely.
- Remove washer fluid from reservoir with suction gun then reinstall (previously removed fluid).



Figure 4

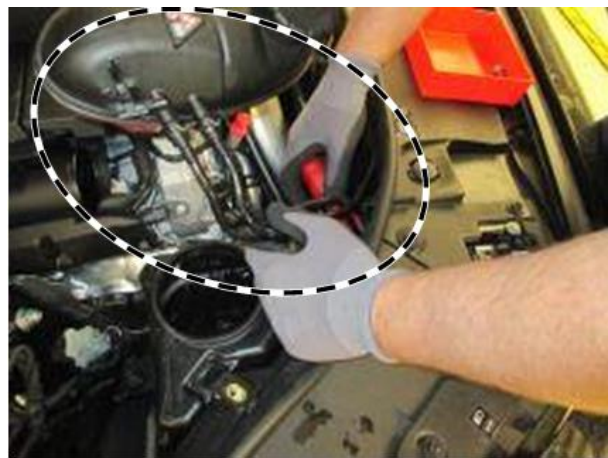

Figure 5



Figure 6

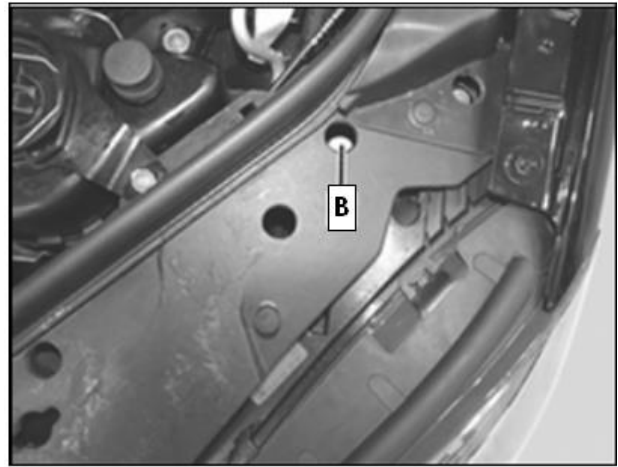

Figure 7

4. Use adjuster (B, Figure 7) to adjust right low beam.

i Note:

- Do **not** perform zero position adjustment with XENRY.
- To better see the spot (Figure 8) in the headlamp aimer, cover the headlamp with a sheet of paper (Figure 9).

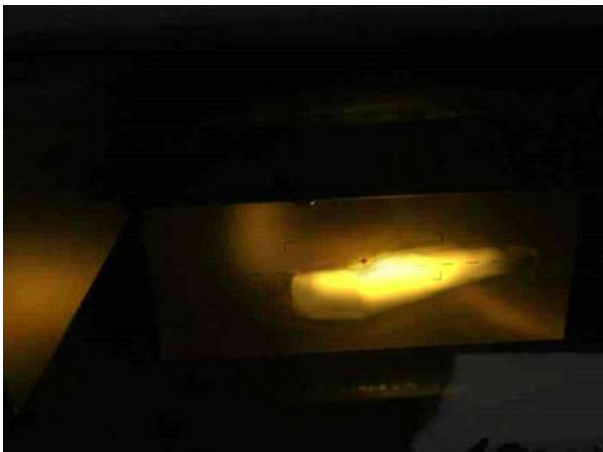

Figure 8

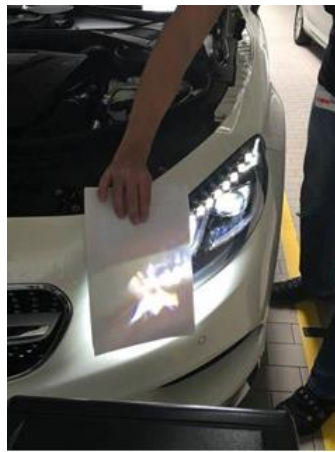

Figure 9

5. Cover outer headlamp (Figure 10).
6. Adjust base light of headlamp (Figure 11) by turning the adjustment screw (B, Figure 12) using a torx socket E5 (Figure 13).

i Note:

Move from the bottom to the top with the base light in the headlamp aimer to the height adjustment reference line.

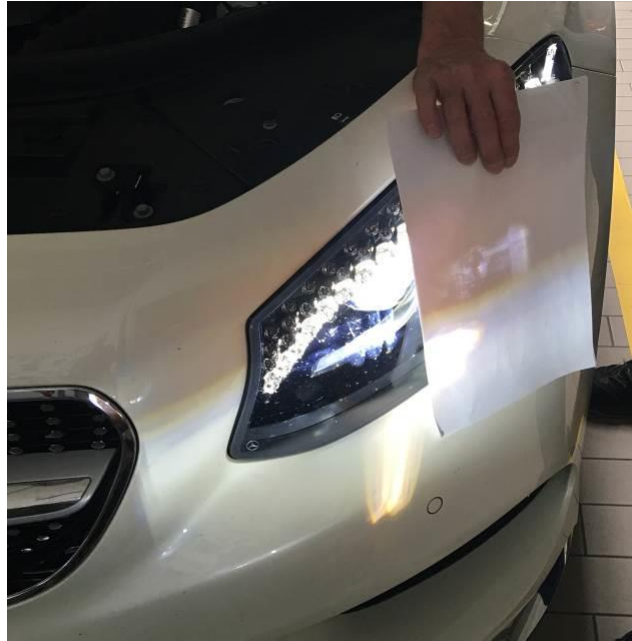

Figure 10

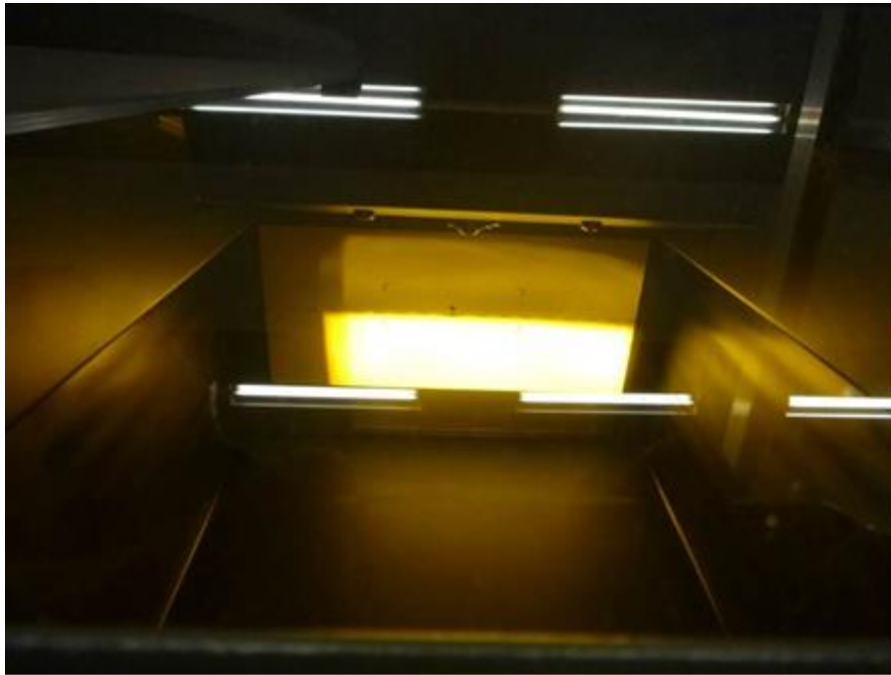

Figure 11 (view in headlamp aimer)

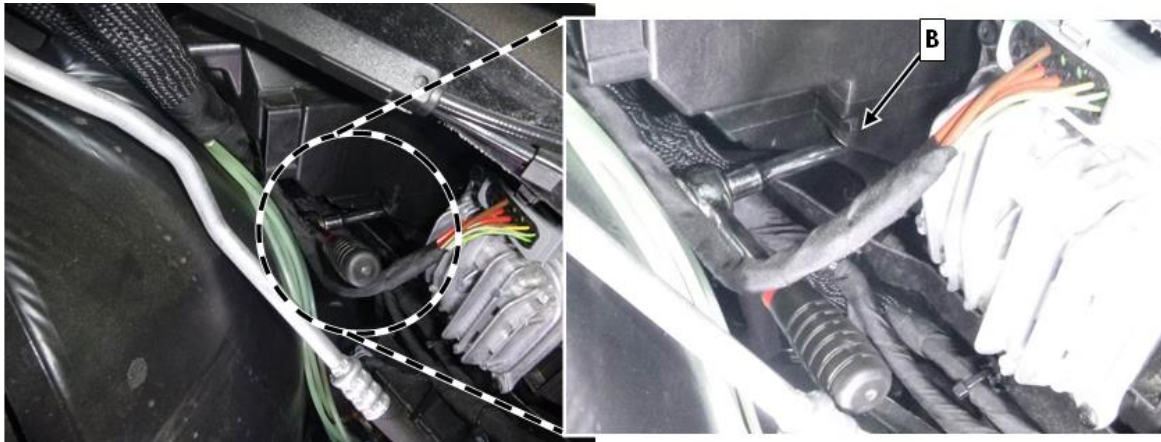

Figure 12 (shown on left headlamp)

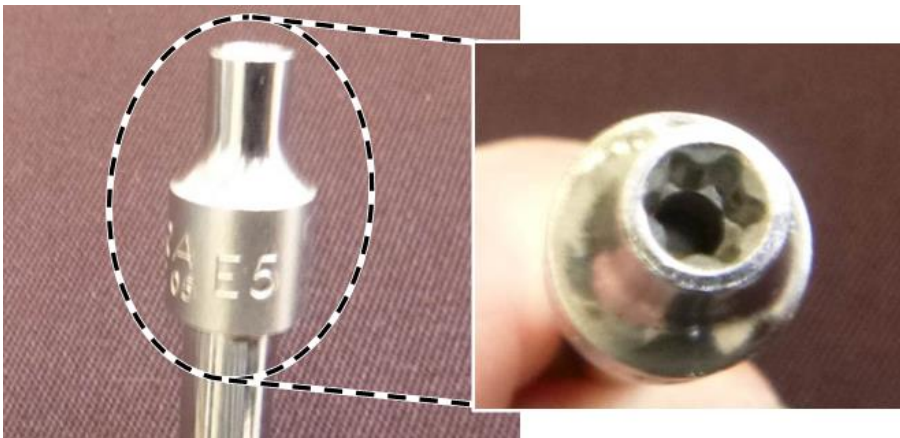





Figure 13

7.  Assemble in reverse order.

C. Adjust Left Low Beam and Headlamp Base Light

 **Note:** Do ***NOT*** remove anti-tamper devices (lead seals).

1.  Remove left engine compartment cover (1, Figure 2).
2. Use adjuster (B, Figure 7) to adjust left low beam.

 **Note:**

- Do ***not*** perform zero position adjustment with XENRY.
- To better see the spot (Figure 8) in the headlamp aimer, cover the headlamp with a sheet of paper (Figure 9).

3. Cover outer headlamp (Figure 10).
4. Adjust base light of headlamp (Figure 11) by turning the adjustment screw (B, Figure 12) using a torx socket E5 (Figure 13).

 **Note:**

Move from the bottom to the top with the base light in the headlamp aimer to the height adjustment reference line.

5.  Assemble in reverse order.

Workshop equipment

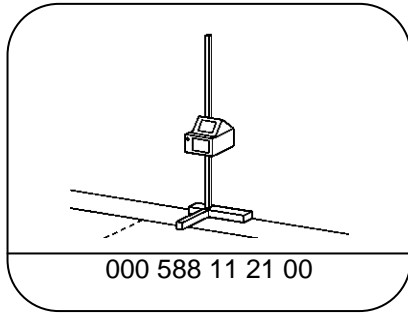

Headlamp aimer

i Note:

- Required equipment as per SSEP on-line catalog.
- Deviating from the headlamp aimers specified in the WIS instructions, the level of the low beams can be adjusted using a **current approved, required headlamp aimer**.

Warranty Information

Repair 1

Operation: Star Diagnosis System (SDS), Connect/disconnect (02-4762)
Check right and left headlamp adjustment (02-9682)

Damage Code	Operation Number	Labor Time (hrs.)
82 918 45 8	02-4762	0.1
	02-9682	0.3

Repair 2

Operation: Star Diagnosis System (SDS), Connect/disconnect (02-4762)
Check right and left headlamp adjustment (02-9682)
Correct base light of right headlamp (02-9683)

Damage Code	Operation Number	Labor Time (hrs.)
82 918 45 8	02-4762	0.1
	02-9682	0.3
	02-9683	0.7

Repair 3

Operation: Star Diagnosis System (SDS), Connect/disconnect (02-4762)
Check right and left headlamp adjustment (02-9682)
Correct base light of left headlamp (02-9684)

Damage Code	Operation Number	Labor Time (hrs.)
82 918 45 8	02-4762	0.1
	02-9682	0.3
	02-9684	0.2

Repair 4

Operation: Star Diagnosis System (SDS), Connect/disconnect (02-4762)
 Check right and left headlamp adjustment (02-9682)
 Correct base light of right headlamp (02-9683)
 Correct base light of left headlamp (02-9684)

Damage Code	Operation Number	Labor Time (hrs.)
82 918 45 8	02-4762	0.1
	02-9682	0.3
	02-9683	0.7
	02-9684	0.2

**Note**

Operation Number labor times are subject to change