

Ferrari

Ferrari North America, Inc.

March 10, 1998

Ms. Kathleen DeMeter, Director
Office of Defects Investigation
National Highway Traffic Safety Administration
400 Seventh Street, SW
Washington, D.C. 20590

98V-058 (01)



Dear Ms. DeMeter:

Enclosed please find Vehicle Safety Defect Initial Information Reports regarding the Recall Campaign which we are initiating in order to correct the following

On Ferrari vehicles, 1997 through 1998 F355 models with assembly numbers between 23604 and 27440, the potential for the fuel injection line to wear due to interference with the water hose clamp on the coolant pipe exists.

Should such a condition occur, the result would be leakage of fuel from the damaged line.

This condition was determined to exist after Ferrari factory laboratory testing showed that interference of the water hose clamp with the fuel injection line can cause the hose clamp to rub through the fuel injection line.

The remedy consists of checking and rotating the incorrectly fitted water hose clamps, as per the diagram.

For the above campaign, it is our intention to notify each Ferrari Dealer with a comprehensive letter explaining the remedy and to notify each potentially affected vehicle owner with a letter informing them of the required recall modification. Follow-up letters will be sent if necessary.

Enclosed are draft letters that Ferrari North America, Inc. will send to the potentially affected owners and to the Authorized Ferrari Dealers, as well as a draft of the technical instructions.



Please do not hesitate to contact me at 201-816-2652 with any questions that you may have regarding the foregoing.

Thank you.

98V-058 (02)

Best regards,

William S. Story - cc

William S. Story
Director of Technical Services

WSS:cc

Enclosures

FERRARI NORTH AMERICA, INC.
250 SYLVAN AVENUE
ENGLEWOOD CLIFFS, NJ 07632
March 6, 1998

VEHICLE SAFETY DEFECT
INITIAL INFORMATION REPORT
WATER HOSE CLAMP
RECALL No. 159

Date Submitted: March-98
Date Received: January-98
Campaign No.: 159
Campaign Date: March-98

<u>MAKE</u>	<u>MODEL</u>	<u>MODEL YEAR</u>	<u>NO. OF VEHICLES</u>	<u>ENCLOSED MFG. DATES</u> <u>From</u> <u>Through</u>	<u>OTHER VEHICLE</u> <u>IDENTIFICATION</u>
FERRARI	F 355	1997-1998	649	Sept. 1996 Sept. 1997	Assembly Numbers 23604-27440

VIN Numbers
106682-110416

98V-058 (03)

FERRARI NORTH AMERICA, INC.
250 SYLVAN AVENUE
ENGLEWOOD CLIFFS, NJ 07632
March 6, 1998

VEHICLE SAFETY DEFECT
INITIAL INFORMATION REPORT
WATER HOSE CLAMP
RECALL No. 159

A) DESCRIPTION OF DEFECT:

On Ferrari Vehicles: Model year 1997-1998 F 355 vehicles.

On Ferrari vehicles, 1997 through 1998 F355 models with assembly numbers between 23604 and 27440, the potential for the fuel injection line to wear due to interference with the water hose clamp on the coolant pipe exists. Should such a condition occur, the result would be leakage of fuel from the damaged line. As with any type of fuel system leakage, the possibility of a vehicle engine fire exists.

B) CHRONOLOGY OF EVENTS WHICH LED TO DETERMINATION OF A SAFETY DEFECT:

The Ferrari Factory informed us of the following:

This condition was determined to exist after laboratory tests have shown that interference of the water hose clamp with the fuel injection line can cause the hose clamp to rub through the fuel injection line.

C) MEASURES TO BE TAKEN TO REPAIR VEHICLE:

The remedy consists of checking and rotating the incorrectly fitted water hose clamps, as per the diagram. This inspection should be performed free of charge and will take approximately 0.2 hours to perform.

ESTIMATED INITIATION OF CORRECTIVE ACTION:

March-98

DRAFT

March 1998

98V-058 (05)

Dear Ferrari Customer,

This notice is sent to you in accordance with the requirements of the National Traffic and Motor Vehicle Safety Act

Ferrari S.p.A., the manufacturer of Ferrari automobiles, has determined that a defect exists in certain 1997 and 1998 model year F355 Ferrari vehicles.

On Ferrari vehicles, 1997 through 1998 F355 models with assembly numbers between 23604 and 27440, the potential for the fuel injection line to wear due to interference with the water hose clamp on the coolant pipe exists. As with any type of fuel system leakage, the possibility of a vehicle engine fire exists.

The remedy consists of checking and rotating the incorrectly fitted water hose clamps, as per the diagram.

The corrective action will require approximately 0.2 hours. Please plan, however, to leave your vehicle with the dealer all day to allow the dealer some flexibility for scheduling your repairs.

By the time you receive this letter, the Authorized Ferrari Dealer will have been supplied with the instructions to perform the repair. If the Dealer fails or is unable to make the necessary repairs free of charge within a reasonable time, you should inform the National Headquarters Office of Ferrari North America, Inc.

250 Sylvan Avenue
Englewood Cliffs, NJ 07632
(201) 816-2651 (National Technical Office)

Although we urge you to immediately call the number indicated above, if the vehicle is not repaired free of charge to you or within a reasonable time, you may also contact the Administrator of the National Traffic Safety Administration in Washington, D.C. 10590 or call the Auto Safety Hot line at 800-424-9393 nationally and (202) 366-0123 for Washington, D.C. area residents.

We urge you to comply with this notice promptly and we apologize for any inconvenience this may cause you.

Best Regards,

William S. Story
Directory of Technical Services

WSS:cc

DRAFT

March 1998

98V-058 (06)

Dear Ferrari Dealer :

Ferrari S.p.A., the manufacturer of Ferrari automobiles, has determined that a defect exists in certain 1997 and 1998 model year F355 Ferrari vehicles.

On Ferrari vehicles, 1997 through 1998 F355 models with assembly numbers between 23604 and 27440, the potential for the fuel injection line to wear due to interference with the water hose clamp on the coolant pipe exists. As with any type of fuel system leakage, the possibility of a vehicle engine fire exists.

The remedy consists of checking and rotating the incorrectly fitted water hose clamps, as per the diagram.

The corrective action will require approximately 0.2 hours.

We have accordingly sent notices to all owners of the affected vehicles advising them of this problem and requesting that they contact any Authorized Ferrari Dealer for the repairs, as per the attached notification letter.

Upon transmittal of the repair under the normal warranty system, we will of course reimburse you for the labor necessary to carry out this campaign.

Obviously, if you have any of the affected vehicles in your stock, you must not sell them until you have performed the necessary repairs. If you have already sold any vehicles with the chassis numbers specified in the enclosed instructions and have not yet sent in the retail sales cards, please do so at once so we may notify these owners.

Thank you for your cooperation.

Best Regards,

William S. Story
Directory of Technical Services

WSS:cc

DRAFT

RECALL CAMPAIGN NO. 159

98V-058 (07)

INTRODUCTION : Water Hose Clamp

SUBJECT : Recall Campaign No. 159
Ferrari F355 Water Hose Clamp

VEHICLES : Ferrari F 355 1997 through 1998 vehicles with a vehicle identification number between 106682 and 110416.

CONDITION : The potential for the fuel injection line to wear due to interference with the water hose clamp on the coolant pipe exists.

REMEDY : Checking and rotating the incorrectly fitted water hose clamps, as per the diagram.

PARTS : NONE

LABOR :	MEDEA Recall No.	1590	Defect Code	01
	Component Code	1776	Cost Code	24
	Labor Operation	17760	Time	0.2 Hours

REIMBURSEMENT : Upon receipt of claim via MEDEA

INSTRUCTIONS FOR WATER HOSE CLAMP ADJUSTMENT

A: Procedure for Adjustment

98V-058 (08)

WARNING : NO SMOKING

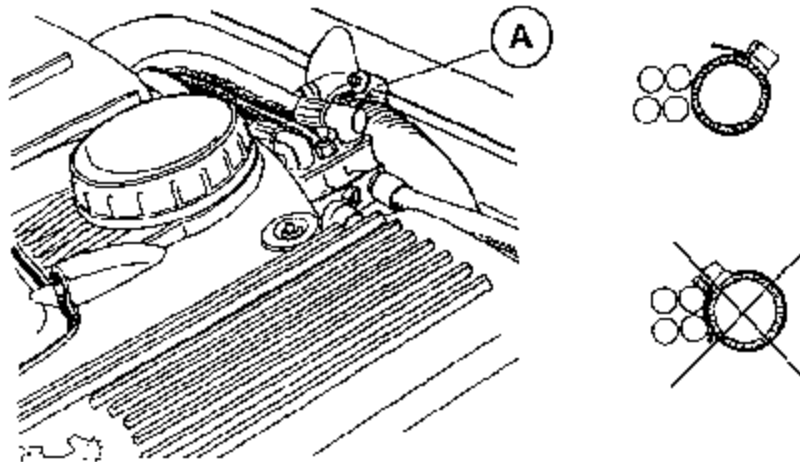

1. Rotate the clamp (p.n. 12177090) which connects the water hose to the coolant pipe as per the above diagram. Turn and tighten the clamp so there is enough clearance as to not interfere and damage the fuel line 171344 (old p.n. 165533).

NOTE: FOR IDENTIFICATION PURPOSES, PLEASE PAINT A YELLOW SPOT ON THE WATER HOSE

Ferrari

Ferrari North America, Inc.

RECEIVED

MAR 27 1998

61101

DEFECTS INVESTIGATION

March 24, 1998

Via U.S. Mail

98V-058

Ms. Kathleen DeMeter, Director
Office of Defects Investigation
National Highway Traffic Safety Administration
400 Seventh Street, SW
Washington, D.C. 20590



Ref: Recall 158 and 159

Dear Ms. DeMeter:

For your records, enclosed please find a the Ferrari North America Inc. booklets for Recalls 158 and 159, Fuel Injection Lines (Single Fuel Pump Vehicles) and Water Hose Clamp, which were sent to all of the dealers in our network.

Best regards,

Concetta Ciaccio
Executive Assistant

Enclosure

Q:RECALL158159-159-BOOK



Q8V-058

RECALL CAMPAIGN

REF. NO. 159
WATER HOSE CLAMP
F 355

MARCH 1998

READ, INITIAL
AND PASS ON »

Service Manager	Parts Manager	Service Writer	Technician				Warranty Clerk



March 1998

Dear Ferrari Dealer:

Ferrari S.p.A., the manufacturer of Ferrari automobiles, has determined that a defect exists in certain 1997 and 1998 model year F355 Ferrari vehicles.

On Ferrari vehicles, 1997 through 1998 F355 models with assembly numbers between 23604 and 27440, the potential for the fuel injection line to wear due to interference with the water hose clamp on the coolant pipe exists. As with any type of fuel system leakage, the possibility of a vehicle engine fire exists.

The remedy consists of checking and rotating the incorrectly fitted water hose clamps, as per the diagram.

The corrective action will require approximately 0.2 hours.

We have accordingly sent notices to all owners of the affected vehicles advising them of this problem and requesting that they contact any Authorized Ferrari Dealer for the repairs, as per the attached notification letter.

Upon transmittal of the repair under the normal warranty system, we will of course reimburse you for the labor necessary to carry out this campaign.

Obviously, if you have any of the affected vehicles in your stock, you must not sell them until you have performed the necessary repairs. If you have already sold any vehicles with the chassis numbers specified in the enclosed instructions and have not yet sent in the retail sales cards, please do so at once so we may notify these owners.

Thank you for your cooperation.

Best Regards,

A handwritten signature in black ink, appearing to read "William S. Story". The signature is written in a cursive style with a long horizontal stroke extending to the right.

William S. Story
Directory of Technical Services

WSS:cc



RECALL CAMPAIGN NO. 159

INTRODUCTION : Water Hose Clamp

SUBJECT : Recall Campaign No. 159
Ferrari F355 Water Hose Clamp

VEHICLES : Ferrari F 355 1997 through 1998 vehicles with a vehicle identification number between 106682 and 110416.

CONDITION : The potential for the fuel injection line to wear due to interference with the water hose clamp on the coolant pipe exists.

REMEDY : Checking and rotating the incorrectly fitted water hose clamps, as per the diagram.

PARTS : NONE

LABOR :	MEDEA Recall No.	1590	Defect Code	01
	Component Code	1776	Cost Code	24
	Labor Operation	17760	Time	0.2 Hours

REIMBURSEMENT : Upon receipt of claim via MEDEA



INSTRUCTIONS FOR WATER HOSE CLAMP ADJUSTMENT

A: Procedure for Adjustment

WARNING : **NO SMOKING**

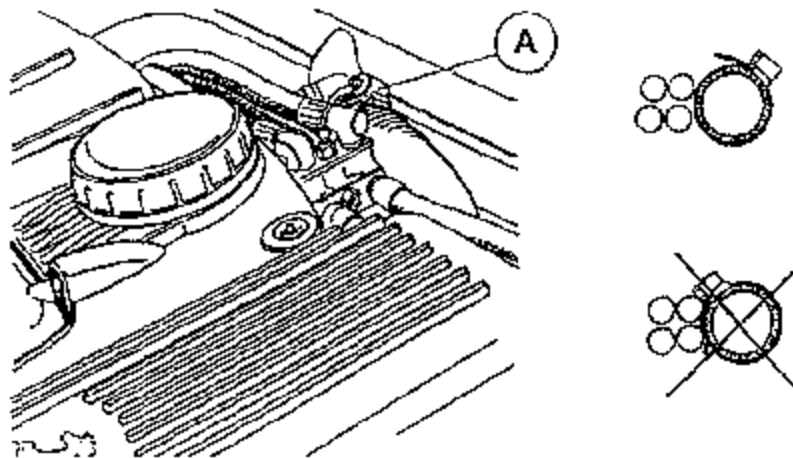

1. Rotate the clamp (p.n. 12177090) which connects the water hose to the coolant pipe as per the above diagram. Turn and tighten the clamp so there is enough clearance as to not interfere and damage the fuel line 171344 (old p.n. 165533).

NOTE: FOR IDENTIFICATION PURPOSES, PLEASE PAINT A YELLOW SPOT ON THE WATER HOSE



Recall Campaign No. 158
Serial Number List

<u>Serial Number</u>	<u>Assembly Number</u>	<u>Model Description</u>
106682	23604	F355 GTS USA MY97
106696	23806	F355 GTS USA MY97
106709	23814	F355 GTS USA MY97
106733	23609	F355 B USA MY97
106748	23631	F355 B USA MY97
106754	23623	F355 SPIDER USA MY97
106756	23635	F355 SPIDER USA MY97
106763	23629	F355 B USA MY97
106769	23612	F355 SPIDER USA MY97
106771	23621	F355 SPIDER USA MY97
106778	23675	F355 B USA MY97
106784	23643	F355 SPIDER USA MY97
106786	23650	F355 SPIDER USA MY97
106793	23711	F355 B USA MY97
106798	23660	F355 SPIDER USA MY97
106799	23653	F355 SPIDER USA MY97
106814	23677	F355 SPIDER USA MY97
106816	23666	F355 SPIDER USA MY97
106824	23694	F355 B USA MY97
106829	23690	F355 SPIDER USA MY97
106831	23683	F355 SPIDER USA MY97
106839	23726	F355 B USA MY97
106844	23704	F355 SPIDER USA MY97
106846	23701	F355 SPIDER USA MY97
106856	23736	F355 B USA MY97
106861	23749	F355 SPIDER USA MY97
106862	23720	F355 SPIDER USA MY97
106869	23752	F355 B USA MY97
106874	23728	F355 SPIDER USA MY97
106876	23730	F355 SPIDER USA MY97
106887	23739	F355 SPIDER USA MY97
106888	23759	F355 SPIDER USA MY97
106889	23765	F355 SPIDER USA MY97
106943	23782	F355 SPIDER USA MY97
106944	23768	F355 SPIDER USA MY97
106946	23794	F355 SPIDER USA MY97
106968	23812	F355 B USA MY97
106976	23790	F355 SPIDER USA MY97
106979	23871	F355 B USA MY97
106988	23802	F355 SPIDER USA MY97
106989	23818	F355 SPIDER USA MY97
106993	23829	F355 B USA MY97
106998	23823	F355 GTS USA MY97
107002	23844	F355 GTS USA MY97
107004	23862	F355 SPIDER USA MY97
107009	23842	F355 B USA MY97



107018	23860	F355 GTS USA MY97
107019	23836	F355 SPIDER USA MY97
107027	23877	F355 B USA MY97
107036	23852	F355 GTS USA MY97
107038	23850	F355 SPIDER USA MY97
107039	23855	F355 SPIDER USA MY97
107043	23883	F355 B USA MY97
107052	23875	F355 GTS USA MY97
107053	23897	F355 GTS USA MY97
107064	23904	F355 B USA MY97
107066	23906	F355 B USA MY97
107069	23889	F355 GTS USA MY97
107072	23894	F355 SPIDER USA MY97
107083	23939	F355 B USA MY97
107086	23924	F355 GTS USA MY97
107091	23902	F355 SPIDER USA MY97
107092	23918	F355 SPIDER USA MY97
107103	23987	F355 B USA MY97
107106	23930	F355 GTS USA MY97
107107	24692	F355 GTS CANADA MY97
107109	23915	F355 SPIDER USA MY97
107121	25207	F355 GTS CANADA MY97
107123	23932	F355 SPIDER USA MY97
107124	23947	F355 SPIDER USA MY97
107126	23945	F355 SPIDER USA MY97
107138	23926	F355 SPIDER USA MY97
107139	23964	F355 SP USAMY97
107141	23961	F355 SP USAMY97
107152	23974	F355 SP USAMY97
107153	23952	F355 SPIDER USA MY97
107154	23977	F355 SP USAMY97
107167	23980	F355 SP USAMY97
107168	23970	F355 SP USAMY97
107169	23989	F355 SP USAMY97
107182	24003	F355 SP USAMY97
107183	24006	F355 SP USAMY97
107196	24023	F355 SP USAMY97
107197	24019	F355 SP USAMY97
107198	24025	F355 SP USAMY97
107211	24016	F355 SP USAMY97
107212	24027	F355 SP USAMY97
107223	24036	F355 SP USAMY97
107224	24046	F355 SP USAMY97
107227	24050	F355 SP USAMY97
107242	24075	F355 SP USAMY97
107243	24062	F355 SP USAMY97
107256	24064	F355 SP USAMY97
107257	24048	F355 SP USAMY97
107258	24032	F355 SP USAMY97
107309	23928	F355 GTS USA MY97
107311	23943	F355 GTS USA MY97



107312	24021	F355 SP CDNMY97
107324	24054	F355 SP USAMY97
107325	24086	F355 SP USAMY97
107336	24079	F355 SP USAMY97
107337	24139	F355 SP USAMY97
107371	24434	F355 B USA MY97
107376	24128	F355 GTS USA MY97
107378	24158	F355 SP USAMY97
107381	24126	F355 B USA MY97
107387	24136	F355 GTS USA MY97
107389	24170	F355 SP CDNMY97
107393	24153	F355 B USA MY97
107399	24159	F355 GTS USA MY97
107405	24184	F355 B USA MY97
107411	24181	F355 GTS USA MY97
107414	24166	F355 SP USAMY97
107418	24201	F355 B USA MY97
107423	24211	F355 GTS USA MY97
107426	24168	F355 SP USAMY97
107434	24225	F355 B USA MY97
107437	24172	F355 SP USAMY97
107438	24209	F355 SP USAMY97
107449	24222	F355 SP USAMY97
107450	24213	F355 SP USAMY97
107461	24227	F355 SP USAMY97
107462	24234	F355 SP USAMY97
107473	24257	F355 SP USAMY97
107474	24250	F355 SP USAMY97
107475	24252	F355 SP USAMY97
107486	24261	F355 SP USAMY97
107487	24259	F355 SP USAMY97
107498	24269	F355 SP USAMY97
107499	24285	F355 SP USAMY97
107501	24314	F355 SP USAMY97
107512	24299	F355 SP USAMY97
107513	24293	F355 SP USAMY97
107524	24302	F355 SP USAMY97
107525	24326	F355 SP USAMY97
107526	24316	F355 SP USAMY97
107539	24318	F355 SP USAMY97
107540	24311	F355 SP USAMY97
107549	24331	F355 SP USAMY97
107550	24329	F355 SP USAMY97
107551	24342	F355 SP USAMY97
107561	24339	F355 SP USAMY97
107562	24355	F355 SP USAMY97
107571	24346	F355 SP USAMY97
107572	24364	F355 SP USAMY97
107573	24373	F355 SP USAMY97
107584	24368	F355 SP USAMY97
107585	24380	F355 SP USAMY97



107647	24652	F355 SPIDER G.D.REGNO U.
107648	24384	F355 SP USAMY97
107650	24390	F355 SP USAMY97
107652	24387	F355 SP USAMY97
107654	24402	F355 SP USAMY97
107656	24405	F355 SP USAMY97
107658	24408	F355 SP USAMY97
107660	24410	F355 SP USAMY97
107662	24419	F355 SP USAMY97
107665	24461	F355 SP USAMY97
107668	24426	F355 B USA MY97
107670	24422	F355 GTS USA MY97
107677	24446	F355 GTS USA MY97
107683	24442	F355 B USA MY97
107689	24455	F355 SP USAMY97
107690	24465	F355 SP USAMY97
107694	24473	F355 GTS USA MY97
107697	24476	F355 SP USAMY97
107698	24463	F355 SP USAMY97
107704	24929	F355 B USA MY97
107707	24491	F355 SP USAMY97
107708	24481	F355 SP USAMY97
107709	24485	F355 SP USAMY97
107721	24493	F355 SP USAMY97
107722	24495	F355 SP USAMY97
107728	24981	F355 B USA MY97
107733	24509	F355 SP USAMY97
107734	24513	F355 SP USAMY97
107735	24515	F355 SP USAMY97
107748	24518	F355 SP USAMY97
107749	24532	F355 SP USAMY97
107750	24524	F355 SP USAMY97
107751	24534	F355 SP USAMY97
107760	24536	F355 SP USAMY97
107761	24543	F355 SP USAMY97
107762	24542	F355 SP USAMY97
107763	24547	F355 SP USAMY97
107771	24560	F355 SP USAMY97
107772	24557	F355 SP USAMY97
107773	24548	F355 SP USAMY97
107774	24545	F355 SP USAMY97
107783	24562	F355 SP USAMY97
107784	24584	F355 SP USAMY97
107785	24563	F355 SP USAMY97
107786	24566	F355 SP USAMY97
107796	24578	F355 SP USAMY97
107797	24576	F355 SP USAMY97
107798	24588	F355 SP USAMY97
107799	24501	F355 SP USAMY97
107808	24593	F355 SP USAMY97
107809	24601	F355 SP USAMY97



107810	24605	F355 SP USAMY97
107811	24607	F355 SP USAMY97
107817	24622	F355 SP USAMY97
107818	24620	F355 SP USAMY97
107819	24610	F355 SP USAMY97
107820	24612	F355 SP USAMY97
107832	24636	F355 SP USAMY97
107833	24690	F355 SP USAMY97
107834	24697	F355 SP USAMY97
107835	24716	F355 SP USAMY97
107869	24747	F 355 CHALLENGE
107882	24772	F 355 CHALLENGE
107893	25062	F355 B USA MY97
107895	24668	F355 B CANADA MY97
107899	24708	F355 SP USAMY97
107904	24710	F355 SP USAMY97
107915	24503	F355 GTS USA MY97
107927	24729	F355 SP USAMY97
107928	24733	F355 SP USAMY97
107929	24723	F355 SP USAMY97
107930	24517	F355 GTS USA MY97
107933	24726	F355 SP CDNMY97
107936	24735	F355 SP USAMY97
107937	24737	F355 SP USAMY97
107938	24753	F355 SP USAMY97
107939	24759	F355 SP USAMY97
107954	24982	F 355 CHALLENGE
107961	25075	F 355 CHALLENGE
107962	25084	F 355 CHALLENGE
107980	25090	F 355 CHALLENGE
107961	25097	F 355 CHALLENGE
107990	25104	F 355 CHALLENGE
107997	24769	F355 SP USAMY97
107998	24771	F355 SP USAMY97
108009	24789	F355 SP USAMY97
108010	24786	F355 SP USAMY97
108015	24801	F355 SP USAMY97
108016	24792	F355 SP USAMY97
108023	24816	F355 SP USAMY97
108024	24805	F355 SP USAMY97
108035	24818	F355 SP USAMY97
108036	24842	F355 SP USAMY97
108046	24836	F355 SP USAMY97
108054	24847	F355 SP USAMY97
108055	24872	F355 SP USAMY97
108056	24850	F355 SP USAMY97
108066	24860	F355 SP USAMY97
108067	24891	F355 SP USAMY97
108076	24863	F355 SP USAMY97
108077	24874	F355 SP USAMY97
108078	24877	F355 SP USAMY97



108120	24934	F355 B CANADA MY97
108126	24938	F355 SP CDNMY97
108132	24972	F355 B CANADA MY97
108137	24948	F355 SP CDNMY97
108143	24924	F355 GTS USA MY97
108145	25116	F 355 CHALLENGE
108146	24935	F355 SP USAMY97
108149	24968	F355 SP CDNMY97
108155	25113	F 355 CHALLENGE
108161	24983	F355 SP CDNMY97
108165	25005	F355 B USA MY97
108170	24978	F355 GTS USA MY97
108173	24915	F355 SP USAMY97
108174	25024	F355 SP CDNMY97
108184	24926	F355 SP USAMY97
108186	24940	F355 SP USAMY97
108191	25039	F355 B USA MY97
108197	24980	F355 SP USAMY97
108198	25067	F355 SP USAMY97
108199	25026	F355 SP USAMY97
108206	24993	F355 GTS USA MY97
108211	25037	F355 SP USAMY97
108212	25028	F355 SP USAMY97
108226	24999	F355 GTS USA MY97
108232	25045	F355 SP USAMY97
108233	25052	F355 SP USAMY97
108238	25009	F355 GTS USA MY97
108245	25057	F355 SP USAMY97
108246	25059	F355 SP USAMY97
108253	25025	F355 GTS USA MY97
108256	25035	F355 SP CDNMY97
108258	25060	F355 SP USAMY97
108259	25061	F355 SP USAMY97
108260	25067	F355 SP USAMY97
108265	25041	F355 GTS USA MY97
108270	25069	F355 SP USAMY97
108271	25071	F355 SP USAMY97
108272	25076	F355 SP USAMY97
108281	25089	F355 SP USAMY97
108282	25091	F355 SP USAMY97
108283	25100	F355 SP USAMY97
108284	25128	F355 SP USAMY97
108295	25102	F355 SP USAMY97
108296	25120	F355 SP USAMY97
108350	25121	F 355 CHALLENGE
108351	25131	F 355 CHALLENGE
108361	25132	F355 SP USAMY97
108362	25140	F355 SP USAMY97
108363	25142	F355 SP USAMY97
108364	25147	F355 SP USAMY97
108365	25145	F355 SP USAMY97



108366	25163	F355 SP USAMY97
108375	25150	F355 SP USAMY97
108376	25166	F355 SP USAMY97
108377	25159	F355 SP USAMY97
108378	25173	F355 SP USAMY97
108385	25192	F355 GTS USA MY97
108388	25176	F355 SP USAMY97
108389	25196	F355 SP CDNMY97
108394	25144	F355 B USA MY97
108400	25190	F355 SP USAMY97
108401	25202	F355 SP USAMY97
108413	25204	F355 SP USAMY97
108414	25232	F355 SP USAMY97
108415	25234	F355 SP CDNMY97
108426	25249	F355 GTS USA MY97
108428	25218	F355 SP USAMY97
108437	25264	F355 B USA MY97
108442	25221	F355 SP USAMY97
108443	25248	F355 SP USAMY97
108444	25252	F355 SP CDNMY97
108455	25266	F355 GTS USA MY97
108456	25240	F355 SP USAMY97
108457	25254	F355 SP USAMY97
108458	25262	F355 SP USAMY97
108472	25269	F355 SP USAMY97
108473	25295	F355 SP USAMY97
108474	25288	F355 SP CDNMY97
108484	25293	F355 GTS USA MY97
108485	25304	F355 GTS USA MY97
108487	25276	F355 SP USAMY97
108488	25282	F355 SP USAMY97
108501	25306	F355 SP USAMY97
108502	25318	F355 SP USAMY97
108503	25312	F355 SP CDNMY97
108508	25321	F355 B USA MY97
108509	25335	F355 B USA MY97
108516	25320	F355 SP USAMY97
108517	25326	F355 SP USAMY97
108530	25328	F355 SP USAMY97
108531	25339	F355 SP USAMY97
108532	25348	F355 SP USAMY97
108533	25346	F355 SP CDNMY97
108542	25354	F355 GTS USA MY97
108543	25365	F355 GTS USA MY97
108547	25344	F355 SP USAMY97
108548	25355	F355 SP USAMY97
108556	25372	F355 B USA MY97
108559	25375	F355 GTS USA MY97
108562	25363	F355 SP USAMY97
108563	25374	F355 SP USAMY97
108572	25395	F355 B USA MY97



108573	25399	F355 B USA MY97
108577	25378	F355 SP USAMY97
108578	25392	F355 SP USAMY97
108593	25394	F355 SP USAMY97
108594	25406	F355 SP USAMY97
108595	25410	F355 SP USAMY97
108605	25447	F355 B USA MY97
108606	25425	F355 B USA MY97
108609	25408	F355 SP USAMY97
108610	25420	F355 SP USAMY97
108621	25430	F355 B USA MY97
108625	25424	F355 SP USAMY97
108626	25433	F355 SP USAMY97
108636	25445	F355 B USA MY97
108638	25442	F355 SP USAMY97
108639	25444	F355 SP USAMY97
108640	25461	F355 SP USAMY97
108663	25451	F355 SP USAMY97
108664	25465	F355 SP USAMY97
108665	25449	F355 SP USAMY97
108674	25467	F355 SP USAMY97
108675	25469	F355 SP USAMY97
108677	25495	F355 B USA MY97
108680	25502	F355 GTS USA MY97
108684	25481	F355 SP USAMY97
108685	25486	F355 SP USAMY97
108688	25521	F355 B USA MY97
108691	25506	F355 GTS USA MY97
108694	25507	F355 SP USAMY97
108695	25503	F355 SP USAMY97
108697	25531	F355 B USA MY97
108700	25535	F355 GTS USA MY97
108704	25517	F355 SP USAMY97
108705	25519	F355 SP USAMY97
108706	25525	F355 SP USAMY97
108707	25536	F355 SP USAMY97
108724	25561	F355 B USA MY97
108727	25544	F355 GTS USA MY97
108736	25547	F355 B USA MY97
108737	25549	F355 B USA MY97
108741	25546	F355 SP USA MY97
108742	25548	F355 SP USA MY97
108750	25568	F355 B USA MY97
108751	25599	F355 B USA MY97
108755	25555	F355 SP USA MY97
108756	25557	F355 SP USA MY97
108765	25580	F355 B USA MY97
108770	25567	F355 SP USA MY97
108771	25595	F355 GTS USA MY97
108772	25585	F355 SP USA MY97
108781	25616	F355 GTS USA MY97



108785	25571	F355 SP USA MY97
108786	25594	F355 SP USA MY97
108787	25611	F355 SP CANADA MY 97
108800	25607	F355 SP USA MY97
108801	25601	F355 SP USA MY97
108802	25613	F355 SP USA MY97
108803	25626	F355 SP CANADA MY 97
108814	25615	F355 SP USA MY97
108815	25624	F355 SP USA MY97
108816	25628	F355 SP USA MY97
108817	25643	F355 SP CANADA MY 97
108823	25664	F355 B USA MY97
108829	25630	F355 SP USA MY97
108830	25641	F355 SP USA MY97
108831	25645	F355 SP USA MY97
108845	25647	F355 SP USA MY97
108846	25649	F355 SP USA MY97
108858	25659	F355 SP USA MY97
108859	25661	F355 SP USA MY97
108860	25674	F355 SP USA MY97
108874	25676	F355 SP USA MY97
108875	25680	F355 SP USA MY97
108876	25689	F355 SP USA MY97
108889	25692	F355 SP USA MY97
108890	25694	F355 SP USA MY97
108891	25709	F355 SP USA MY97
108892	25707	F355 SP USA MY97
108893	25711	F355 SP USA MY97
108905	25705	F355 SP USA MY97
108906	25740	F355 SP USA MY97
108907	25721	F355 SP USA MY97
108908	25723	F355 SP USA MY97
108917	25727	F355 SP USA MY97
108918	25725	F355 SP USA MY97
108919	25784	F355 SP USA MY97
108920	25742	F355 SP USA MY97
108921	25751	F355 SP USA MY97
108934	25775	F355 B USA MY97
108938	25754	F355 SP USA MY97
108941	25749	F355 SP USA MY97
108942	25757	F355 SP USA MY97
108956	25766	F355 SP USA MY97
108957	25773	F355 SP USA MY97
108958	25771	F355 SP USA MY97
108985	25806	F355 B CANADA MY 97
108987	25812	F355 GTS USA MY97
108999	25819	F355 B USA MY97
109000	25835	F355 B CANADA MY 97
109007	25818	F355 SP USA MY97
109008	25817	F355 SP USA MY97
109020	25821	F355 SP USA MY97



109021	25832	F355 SP CANADA MY 97
109022	25834	F355 SP CANADA MY 97
109030	25860	F355 B USA MY97
109036	25853	F355 SP USA MY97
109037	25845	F355 SP USA MY97
109038	25847	F355 SP USA MY97
109045	25928	F355 B USA MY97
109051	25859	F355 SP USA MY97
109052	25862	F355 SP USA MY97
109053	25864	F355 SP USA MY97
109061	25896	F355 B USA MY97
109067	25892	F355 SP USA MY97
109068	25875	F355 SP USA MY97
109069	25876	F355 SP USA MY97
109076	25908	F355 B USA MY97
109082	25893	F355 SP USA MY97
109083	25878	F355 SP USA MY97
109084	25884	F355 SP USA MY97
109087	25900	F355 SP USA MY97
109098	25907	F355 SP USA MY97
109099	25911	F355 SP USA MY97
109112	25920	F355 SP USA MY97
109113	25921	F355 SP USA MY97
109114	25924	F355 SP USA MY97
109122	25944	F355 B USA MY97
109127	25937	F355 SP USA MY97
109128	25939	F355 SP USA MY97
109129	25942	F355 SP USA MY97
109136	25975	F355 B USA MY97
109142	25951	F355 SP USA MY97
109143	25953	F355 SP USA MY97
109144	25961	F355 SP USA MY97
109156	25977	F355 SP USA MY97
109157	25956	F355 SP USA MY97
109158	25984	F355 SP USA MY97
109169	25969	F355 SP USA MY97
109170	25986	F355 SP USA MY97
109171	25991	F355 SP USA MY97
109184	26004	F355 SP USA MY97
109185	25999	F355 SP USA MY97
109186	26002	F355 SP USA MY97
109187	26006	F355 SP USA MY97
109201	26015	F355 SP USA MY97
109202	26017	F355 SP USA MY97
109203	26019	F355 SP USA MY97
109204	26021	F355 SP USA MY97
109214	26033	F355 SP USA MY97
109215	26029	F355 SP USA MY97
109216	26031	F355 SP USA MY97
109217	26035	F355 SP USA MY97
109229	26050	F355 SP USA MY97



109230	26046	F355 SP USA MY97
109231	26044	F355 SP USA MY97
109232	26048	F355 SP USA MY97
109245	26060	F355 SP USA MY97
109246	26090	F355 SP USA MY97
109331	26175	F355 B USA MY97
109333	26188	F355 GTS USA MY97
109335	26168	F355 SP USA MY97
109336	26177	F355 SP USA MY97
109346	26170	F355 SP USA MY97
109347	26186	F355 SP USA MY97
109350	26218	F355 B USA MY97
109354	26197	F355 SP USA MY97
109355	26206	F355 SP USA MY97
109356	26214	F355 SP USA MY97
109360	26222	F355 B USA MY97
109366	26200	F355 SP USA MY97
109367	26215	F355 SP USA MY97
109368	26202	F355 SP USA MY97
109372	26447	F355 B CANADA MY 97
109377	26228	F355 SP USA MY97
109378	26232	F355 SP USA MY97
109379	26221	F355 SP USA MY97
109386	26235	F355 SP USA MY97
109387	26446	F355 SP USA MY97
109388	26448	F355 SP USA MY97
109389	26464	F355 SP USA MY97
109397	26450	F355 SP USA MY97
109398	26459	F355 SP USA MY97
109399	26462	F355 SP USA MY97
109400	26465	F355 SP USA MY97
109407	26470	F355 SP USA MY97
109408	26476	F355 SP USA MY97
109409	26477	F355 SP USA MY97
109410	26478	F355 SP USA MY97
109415	26483	F355 SP USA MY97
109416	26492	F355 SP USA MY97
109417	26494	F355 SP USA MY97
109418	26495	F355 SP USA MY97
109427	26498	F355 SP USA MY97
109428	26506	F355 SP USA MY97
109429	26508	F355 SP USA MY97
109430	26511	F355 SP USA MY97
109437	26526	F355 SP USA MY97
109438	26513	F355 SP USA MY97
109439	26515	F355 SP USA MY97
109440	26523	F355 SP USA MY97
109448	26528	F355 SP USA MY97
109449	26529	F355 SP USA MY97
109450	26531	F355 SP USA MY97
109603	26708	F355 SP USA MY98



109604	26721	F355 SP USA MY98
109615	26731	F355 B USA MY98
109621	26746	F355 SP USA MY98
109622	26728	F355 SP USA MY98
109634	26749	F355 B USA MY98
109635	26770	F355 B USA MY98
109640	26742	F355 SP USA MY98
109641	26732	F355 SP USA MY98
109642	26762	F355 SP USA MY98
109650	26710	F355 B CANADA MY98
109651	26696	F355 GTS USA MY98
109652	26724	F355 GTS USA MY98
109658	26768	F355 SP USA MY98
109659	26774	F355 SP USA MY98
109660	26781	F355 SP USA MY98
109670	26763	F355 B USA MY98
109675	26784	F355 SP USA MY98
109676	26799	F355 SP USA MY98
109677	26802	F355 SP USA MY98
109678	26804	F355 SP USA MY98
109690	26757	F355 GTS USA MY98
109694	26816	F355 SP USA MY98
109695	26832	F355 SP USA MY98
109696	26819	F355 SP USA MY98
109708	26791	F355 B USA MY98
109715	26817	F355 SP USA MY98
109716	26830	F355 SP USA MY98
109717	26834	F355 SP USA MY98
109726	26807	F355 B USA MY98
109727	26824	F355 B USA MY98
109736	26838	F355 SP USA MY98
109750	26772	F355 GTS USA MY98
109753	26848	F355 SP USA MY98
109754	26850	F355 SP USA MY98
109755	26726	F355 SP CANADA MY98
109763	26853	F355 B USA MY98
109764	26868	F355 B USA MY98
109770	26865	F355 SP USA MY98
109771	26863	F355 SP USA MY98
109784	26776	F355 GTS USA MY98
109786	26856	F355 SP USA MY98
109787	26871	F355 SP USA MY98
109798	26857	F355 B USA MY98
109803	26885	F355 SP USA MY98
109804	26887	F355 SP USA MY98
109805	26924	F355 SP USA MY98
109814	26891	F355 B USA MY98
109819	26901	F355 SP USA MY98
109820	26890	F355 SP USA MY98
109828	26909	F355 B USA MY98
109833	26893	F355 SP USA MY98



109834	26897	F355 SP USA MY98
109855	26922	F355 B USA MY98
109856	27148	F355 B USA MY98
109867	26916	F355 SP USA MY98
109868	26912	F355 SP USA MY98
109872	27157	F355 B USA MY98
109909	26938	F355 B CANADA MY98
110045	27088	F355 GTS CANADA MY98
110047	27079	F355 SP CANADA MY98
110062	27128	F355 GTS USA MY98
110079	27099	F355 GTS USA MY98
110110	27175	F355 B USA MY98
110131	27160	F355 SP USA MY98
110133	27162	F355 GTS USA MY98
110141	27218	F355 B USA MY98
110146	27187	F355 GTS USA MY98
110147	27178	F355 SP USA MY98
110156	27222	F355 B USA MY98
110159	27191	F355 GTS USA MY98
110162	27193	F355 SP USA MY98
110171	27236	F355 B USA MY98
110179	27207	F355 SP USA MY98
110189	27253	F355 B USA MY98
110204	27266	F355 B USA MY98
110208	27234	F355 GTS USA MY98
110210	27231	F355 SP USA MY97
110220	27283	F355 B USA MY98
110222	27249	F355 GTS USA MY98
110225	27251	F355 SP USA MY98
110234	27340	F355 B USA MY98
110237	27262	F355 GTS USA MY98
110240	27264	F355 SP USA MY98
110252	27288	F355 GTS USA MY98
110255	27279	F355 SP USA MY98
110269	27290	F355 SP USA MY98
110270	27292	F355 SP USA MY98
110284	27308	F355 SP USA MY98
110298	27320	F355 SP USA MY98
110299	27324	F355 SP USA MY98
110414	27369	F355 B USA MY98
110415	27382	F355 B USA MY98
110416	27398	F355 B USA MY98



March 1998

Dear Ferrari Customer:

This notice is sent to you in accordance with the requirements of the National Traffic and Motor Vehicle Safety Act.

Ferrari S.p.A., the manufacturer of Ferrari automobiles, has determined that a defect exists in certain 1997 and 1998 model year F355 Ferrari vehicles.

On Ferrari vehicles, 1997 through 1998 F355 models with assembly numbers between 23604 and 27440, the potential for the fuel injection line to wear due to interference with the water hose clamp on the coolant pipe exists. As with any type of fuel system leakage, the possibility of a vehicle engine fire exists.

The remedy consists of checking and rotating the incorrectly fitted water hose clamps, as per the diagram.

The corrective action will require approximately 0.2 hours. Please plan, however, to leave your vehicle with the dealer all day to allow the dealer some flexibility for scheduling your repairs.

By the time you receive this letter, the Authorized Ferrari Dealer will have been supplied with the instructions to perform the repair. If the Dealer fails or is unable to make the necessary repairs free of charge within a reasonable time, you should inform the National Headquarters Office of Ferrari North America, Inc.

250 Sylvan Avenue
Englewood Cliffs, NJ 07632
(201) 816-2651 (National Technical Office)

Although we urge you to immediately call the number indicated above, if the vehicle is not repaired free of charge to you or within a reasonable time, you may also contact the Administrator of the National Traffic Safety Administration in Washington, D.C. 10590 or call the Auto Safety Hot line at 800-424-9393 nationally and (202) 366-0123 for Washington, D.C. area residents.

We urge you to comply with this notice promptly and we apologize for any inconvenience this may cause you.

Best Regards,

William S. Story
Directory of Technical Services

WSS:cc