

Ferrari

Ferrari North America, Inc.
250 Sylvan Avenue
Englewood Cliffs, NJ 07632
201-816-2600
TLX: 248021
FAX: 201-816-2626

RECEIVED

92 SEP 15 PM 3:15

OFFICE
DEFECTS INVESTIGATION

September 11, 1992

Mr. Charles L. Gauthier, Director
Office of Defects Investigation
National Highway Traffic
Safety Administration
Washington, D.C.

Re: Recall Campaign No. 92V-071 -
Fuel Injection Lines
Ferrari 348 and Mondial T models

Dear Director:

Pursuant to my August 13, 1992 meeting with Mr. John Abbott, Ferrari S.p.A. has decided to expand the above referenced Recall Campaign. This Recall Campaign will now encompass all Ferrari 348 and Mondial T vehicles manufactured up to and including chassis number 92207.

Therefore, we have amended the Vehicle Safety Defect Initial Information Report to reflect the above mentioned change:

On vehicles with Vehicle Identification Number lower than 92208, the aluminum fuel line fittings on certain fuel injection lines can corrode under extreme environmental conditions. Should such condition remain unnoticed, the result could be breakage of the aluminum fuel line fitting resulting in fuel leakage. As with any type of fuel system leakage, the possibility of a vehicle engine fire may exist.

The corrective action will require approximately 1.5 hours.

It is our intention to notify our Authorized Ferrari Dealers with a comprehensive letter informing them



of the expansion of this campaign to include vehicles below chassis number 92202. Furthermore, it is our intention to notify each vehicle owner by letter by the first half of October, 1992, so as to explain the required recall modifications.

Enclosed are draft copies of the letters Ferrari North America, Inc. will send to the vehicle owners and to the Ferrari North America Dealers. Also, enclosed are the accompanying technical instructions.

Yours truly,

Kenneth W. McGay
Technical Director
Ferrari North America, Inc.

encl.

KWM/rlf



FERRARI NORTH AMERICA, INC.
250 SYLVAN AVENUE
ENGLEWOOD CLIFFS, N.J. 07632

**VEHICLE SAFETY DEFECT
INITIAL INFORMATION REPORT**

**348 ts/tb & Mondial t - Fuel injection lines
Recall No. 147**

A) DESCRIPTION OF DEFECT:

On vehicles with Vehicle Identification Number lower than 92208, the aluminum fuel line fittings on certain fuel injection lines can corrode under extreme environmental conditions. Should such condition remain unnoticed, the result could be breakage of the aluminum fuel line fitting resulting in fuel leakage.

B) CHRONOLOGY OF EVENTS WHICH LED TO DETERMINATION OF A SAFETY DEFECT:

As a result of extended durability testing, Ferrari S.p.A. discovered that the aluminum fittings on certain fuel injection lines may corrode if exposed extreme environmental conditions.

C) MEASURES TO BE TAKEN TO REPAIR VEHICLE:

The remedy consists in the replacement of the four fuel injection lines with modified fuel lines which are now constructed with a corrosion resistant coating to prevent fuel line surface corrosion. The operation is free-of-charge for the vehicle owner, and will require approximately .60 hours for 348 ts/tb and 1.2 hours for Mondial t coupe and cabriolet.

INITIATION OF CORRECTIVE ACTION:

JUNE 1992

ESTIMATED INITIATION OF RECALL REVISION:

SEPTEMBER-1992

October

**VEHICLE SAFETY DEFECT
INITIAL INFORMATION REPORT**

Fuel injection lines

Recall No. 147

Date submitted: August 24, 1992

Date received: August 30, 1992

Campaign No. : 147

Campaign Date: Rev. August 1992

ENCLOSED MFG. DATES

MAKE	MODEL	MODEL YEAR	NO. OF VEHICLES	FROM	THROUGH	OTHER VEHICLE IDENTIFICATION
FERRARI	348 TS / TB	1989	134	JULY 1989	JAN. 1990	
FERRARI	MONDIAL T CPE / CAB	1989	208	MAY 1989	AUG. 1989	
FERRARI	348 TS / TB	1990	380	MAR. 1990	DEC. 1990	
FERRARI	MONDIAL T CAB	1990	98	FEB. 1990	DEC. 1990	
FERRARI	348 TS / TB	1991	275	DEC. 1990	JUNE 1991	
FERRARI	MONDIAL T CAB	1991	50	MAR. 1991	JULY 1991	
FERRARI	348 TS / TB	1992	132	JUNE 1991	NOV. 1991	
FERRARI	MONDIAL T CAB	1992	34	JULY 1992	NOV. 1992	

**FOR INTEROFFICE
USE ONLY**

RECALL CAMPAIGN

DRAFT COPY

REF. NO. 147

FUEL INJECTION LINES

REF. NO. 148

**UPPER STEERING COLUMN
LOCKNUT**

REF. NO. 149

**STEERING BOX EXTENSION
FASTENER**

REVISION DATE: SEPTEMBER 1992

**READ, INITIAL
AND PASS ON >>**

Service Manager	Parts Manager	Service Writer	Technician				Warranty Clerk

TABLE OF CONTENTS

<u>TITLE</u>	<u>PAGE</u>
Letter to the Ferrari Dealer	2 - 3
<u>Recall Ref. No. 147</u> 348 ts/tb - Mondial t cpe. / cab. Fuel injection lines	4 - 8
<u>Recall Ref. No. 148</u> 348 ts/tb, Mondial t cpe. / cab. & Testarossa Upper steering column locknut	10 - 11
<u>Recall Ref. No. 149</u> 348 ts/tb Steering box extension fastener	12 - 13
Recall Claim form instructions	14 - 15
Letters to the Customer	16 - 31
Vehicle Master List	30 - 61

Ferrari

Ferrari North America, Inc.
250 Sylvan Avenue
Englewood Cliffs, NJ 07632
201-816-2600
TLX: 6162616
FAX: 201-816-2626

September 1992

Dear Ferrari Dealer:

Ferrari S.p.A., the manufacturer of Ferrari automobiles, has determined that certain defects exist on certain 1989, 1990 and 1991 model year Ferrari vehicles.



- 1) On 348 ts/tb and Mondial t vehicles with Vehicle Identification Number lower than 922, the aluminum fittings on certain *fuel injection lines* can corrode under extreme environmental conditions. Should such condition remain unnoticed, the result could be breakage of the aluminum fuel line fitting resulting in fuel leakage. As with any type of fuel system leak, the possibility of a vehicle engine fire may exist.
- 2) On 348 ts/tb, Mondial t, and Testarossa vehicles with Vehicle Identification Number lower than 87898, the *upper steering column locknut* was manufactured with a lower class of material and self-locking properties. This may result in a loss of tightening torque on the steering column fastener. Should such condition remain unnoticed and the use of the car be prolonged for an extensive period of time, loosening of the fastener could occur resulting in play in the steering system and consequential impairment of handling.
- 3) On 348 ts/tb vehicles with Vehicle Identification Number lower than 86232, the *steering extension fastener* was manufactured with a lower class of material and self-locking properties. This may result in a loss of tightening torque on the upper steering column fastener. Should such condition remain unnoticed and the use of the car be prolonged for an extensive period of time, loosening of the fastener could occur resulting in play in the steering system and consequential impairment of handling.

Instructions for performing the necessary remedies are herewith enclosed. The corrective action will require approximately 1.5 hours.

Accordingly, we have sent notices to all owners of the potentially affected vehicles advising them of these problems and requesting that they contact any authorized Ferrari dealer for the necessary remedy as per the attached notification letter.

Cont.....



Upon receipt of the campaign notice properly signed by the customer and by you or your authorized representative, we will, of course, reimburse you for the labor and applicable parts expended in carrying out these campaigns.

Obviously, if you have any of the potentially affected vehicles in your stock, you must not sell them until you have performed the necessary repairs. If you have already sold any vehicles with the chassis number specified in the enclosed instructions and have not yet sent in the retail sales cards, please do so at once so we may notify these owners.

Thank you for your cooperation.
Very truly yours,

Kenneth McCay
Technical Director
Ferrari North America, Inc.

RECALL CAMPAIGN NO. 147

INTRODUCTION - Fuel injection lines

- SUBJECT:** Recall Campaign No. 147
Ferrari 348 ts/tb - Mondial t Models - Fuel injection lines
- VEHICLES:** All Ferrari 348 ts/tb and Mondial t Models with the following serial number ranges:
- Ferrari 348 ts/tb, Model Year 1989 through 1992, starting from serial number 82277 up to serial number 92208 included.
 - Ferrari Mondial t coupe and cabriolet, Model Year 1989 through 1992, starting from serial number 81342 up to serial number 92115 included.
- CONDITION:** The aluminum fuel line fittings on certain fuel Injection lines can corrode under extreme environmental conditions. Should such condition remain unnoticed, the result could be breakage of the aluminum fuel line fitting resulting in fuel leakage.
- REMEDY:** Replacement of the Fuel injection system lines "A & B" with the modified fuel lines (shown on Fig 1, page 6).
- PARTS:** Quantities required for each vehicle and identification of the new Fuel lines with the new part numbers, are shown on the Parts List Table "A" on Page 8). The new part fittings are now aluminum with a non-corrosive coating.
- COST:**
- a) An initial supply of new fuel lines will be shipped to your dealership. Your parts account will be charged accordingly. The Table on page 8 indicates the part numbers and quantity required per vehicle.
 - b) Additional fuel return lines can be ordered from the Ferrari North America Parts Department in Englewood Cliffs, New Jersey.
- LABOR:**
- | | |
|---------------|-----------------------|
| Operation No. | 147 |
| Time | 348 ts/tb - 0.8 hours |
| | Mondial t - 1.2 hours |

RECALL CAMPAIGN NO. 147

REIMBURSEMENT: On receipt of the correctly completed recall campaign claim (see Recall Claim form Instructions, page 14).

INSTRUCTIONS FOR FUEL LINE REPLACEMENT

A. Preliminary: The replacement Fuel lines (Fig.#1) are supplied as a spare parts by the part numbers on Table "A", Page 8.

B. Procedure for installation

WARNING: NO SMOKING

HIGHLY FLAMMABLE MATERIAL. KEEP AWAY FROM SPARKS OR OPEN FLAMES. PROVIDE ADEQUATE VENTILATION. FUEL, WHEN SATURATED ON CLOTHING, WILL CAUSE SKIN IRRITATION. PROCEED ACCORDINGLY.

NOTE: BE SURE TO UTILIZE PROPER EQUIPMENT FOR SAFE TRANSFER OF FUEL FROM CAR TO APPROVED FUEL CONTAINER.

DO NOT PERFORM THIS PROCEDURE ON A WARM ENGINE.

- 1) Disconnect battery (Main switch).
- 2) Cover rear fenders (also Trunk lid area) with fender covers.
- 3) Remove Fuel tank fill cap to release pressure from the fuel tank.
- 4) Place a catch pan under the fuel filter and loosen upper filter connection. While fuel is draining, loosen fuel line fitting at regulator end of the Fuel Injection rail. This will allow the remainder of fuel in rail to drain.
- 5) Remove both fuel lines "A & B" as shown in Fig.# 1 and replace with new lines.
- 6) Inspect 1/4 bank Fuel Injection return line for any damage due to contact with the timing cover. If damage is found the line must be replaced using the procedure "C - Procedure for replacement of fuel return line" found on page # 7 of this booklet. If no damage is found, please insure that the return line is secured on the clip found on the timing cover (Fig.#3). Also the Return Fuel line must not contact the Timing cover or A/C Compressor lines.
- 7) Repeat procedure #4 through #6 for 5/8 bank fuel lines.
- 8) Replace fuel tank filler cap.
- 9) Start engine, run for 30 seconds and then shut off. Check for leaks.

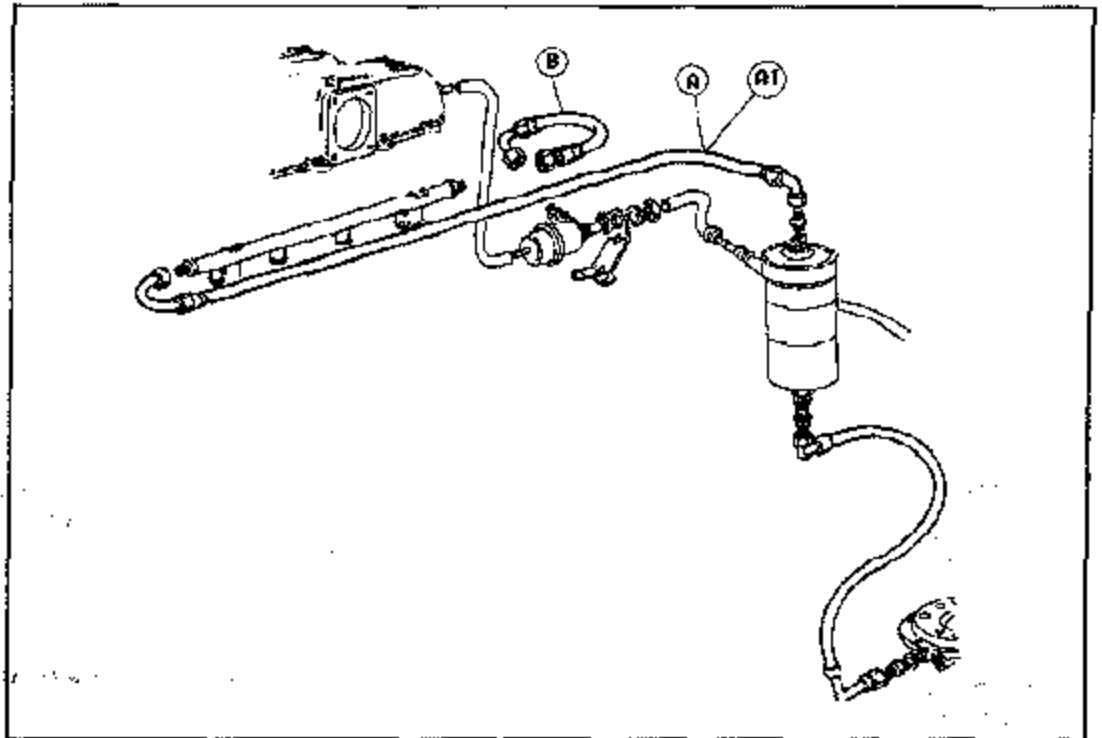
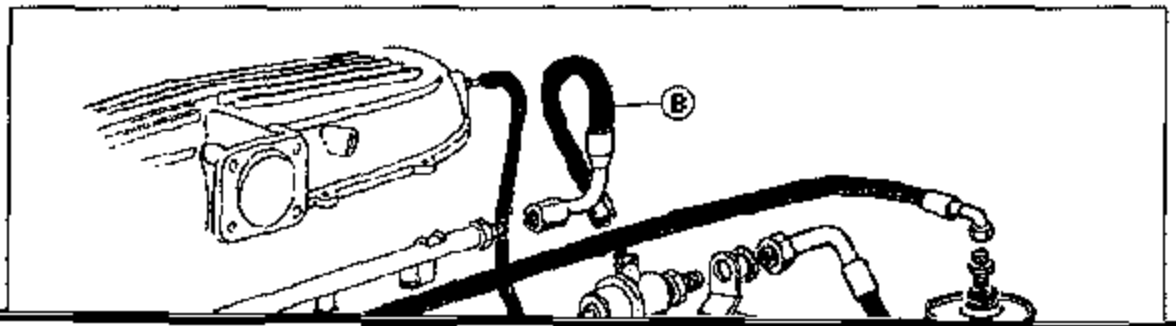

Fig.#1



Recall #147

TABLE "A" PARTS LIST

<u>VEHICLE</u>	<u>PART DESCRIPTION</u>	<u>PART NUMBER</u>	<u>QTY. NEEDED</u>
MONDIAL T COUPE	Sx Fuel line (filter to fuel rail)	143789	1
	Dx Fuel line (filter to fuel rail)	143788	1
	Fuel line (fuel rail to pressure regulator)	149812	2
MONDIAL T CABRIOLET	Sx Fuel line (filter to fuel rail)	143785	1
	Dx Fuel line (filter to fuel rail)	143784	1
	Fuel line (fuel rail to pressure regulator)	149812	2
348 TS / TB	Sx Fuel line (filter to fuel rail)	143787	1
	Dx Fuel line (filter to fuel rail)	143786	1
	Fuel line (fuel rail to pressure regulator)	149812	2

RECALL CAMPAIGN NO. 148

INTRODUCTION - Upper steering column locknut

SUBJECT: Recall Campaign No. 148
Ferrari 348 ts/tb, Mondial t and Testarossa Models
Upper steering column locknut

VEHICLES: All Ferrari 348 ts/tb, Mondial t & Testarossa Models with the following serial number ranges:

- Ferrari 348 ts/tb, Model Year 1990 and 1991, starting from serial number 85389 up to serial number 87898 included.
- Ferrari Mondial t coupe and cabriolet, Model Year 1990, starting from serial number 85927 up to serial number 87908 included.
- Ferrari Testarossa, Model Year 1990 and 1991, starting from serial number 85658 up to serial number 87483 included.

CONDITION: *The upper steering column locknut was manufactured with a lower class of material and self-locking properties. This may result in a loss of tightening torque on the upper steering column fastener. Should such condition remain unnoticed and the use of the car be prolonged for an extensive period of time, loosening of the fastener could occur resulting in play in the steering system and consequential impairment of handling.*

REMEDY: Replacement of the Upper steering column locknut with the improved self-locking nut (shown on Fig 1, page 11).

PARTS: Only one locknut (PN# 150428) required for each vehicle.

COST: An initial supply of new self-locking nuts will be shipped to your dealership. Your parts account will be charged accordingly. Additional self-locking nuts can be ordered from the Ferrari North America Parts Department in Englewood Cliffs, New Jersey.

LABOR: Operation No. 148
Time ALL MODELS - 0.2 hours

REIMBURSEMENT: On receipt of the correctly completed recall campaign claim (see Recall Claim form Instructions, page x).

INSTRUCTIONS FOR LOCKNUT REPLACEMENT

- A. Preliminary: The replacement self-locking nut (Fig.#1a) is supplied as a spare part (PN# 150428) by the Ferrari North America parts department.
- B. Procedure for installation
- 1) Cover interior (seat and carpeting).
 - 2) Remove 13mm locknut from upper steering column fastener and replace with new 13mm self locking nut (PN# 150428) as shown in fig.# 1 below.
 - 3) Check that the steering column shaft is properly inserted into the steering column extension. Fastener must go through the groove provided in the steering column shaft.
 - 4) Torque self-locking nut to 2.3 daNm (17 lbs/ft).
 - 5) Check for binding in steering system. If there is binding, check system for faults.
 - 6) Remove all protective covers from interior and insure that the area is clean.

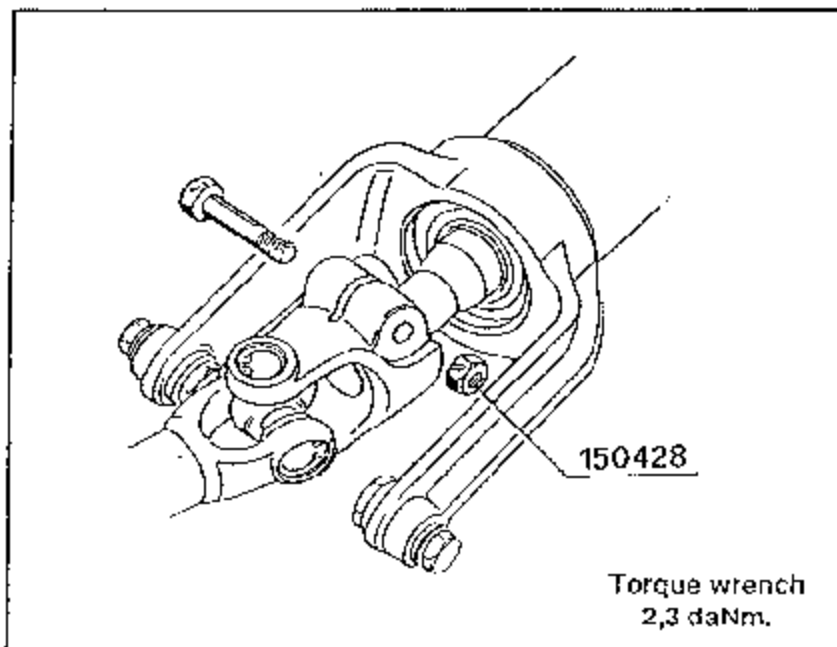

Fig.#1a

RECALL CAMPAIGN NO. 149

INTRODUCTION - Steering box extension fastener

SUBJECT: Recall Campaign No. 149
Ferrari 348 ts/tb Models
Steering box extension fastener

VEHICLES: All Ferrari 348 ts/tb Models with the following serial number ranges:

- Ferrari 348 ts/tb, Model Year 1989 and 1990, starting from serial number 82277 up to serial number 86212 included.

CONDITION: On 348 ts/tb vehicles with Vehicle Identification Number lower than 86212, the *steering box extension fastener* was manufactured with a lower class of material and self-locking properties. This may result in a loss of tightening torque on the upper steering column fastener. Should such condition remain unnoticed and the use of the car be prolonged for an extensive period of time, loosening of the fastener could occur resulting in play in the steering system and consequential impairment of handling.

REMEDY: Replacement of the Steering box extension fastener with the improved fastener (shown on Fig 1, page 13).

PARTS: One set of the following is required for each vehicle:

- | | | |
|------------------|-------------|--------------|
| a) Fastener bolt | PN#125518 | Quantity - 1 |
| b) Locknut | PN#12574221 | Quantity - 1 |
| c) Washer | PN#12601274 | Quantity - 2 |

COST: An initial supply of these parts will be shipped to your dealership. Your parts account will be charged accordingly. Additional supplies of these parts can be ordered from the Ferrari North America Parts Department in Englewood Cliffs, New Jersey.

LABOR: Operation No. 149
Time 0.1 hours

REIMBURSEMENT: On receipt of the correctly completed recall campaign claim (see Recall Claim form Instructions, page x).

INSTRUCTIONS FOR FASTENER REPLACEMENT

A. Preliminary: The replacement Fastener, bolt and washers (Fig.#1) are supplied as a spare parts by the Ferrari North America parts department using the part numbers listed on "parts" section of page 12.

B. Procedure for installation

- 1) Cover interior (seat and carpeting).
- 2) Move carpeting away from area of steering extension located under the dash at the base of the front cabin wall.
- 3) Remove 10mm locknut from steering extension fastener and remove the fastener.
- 4) Check that the steering box shaft is properly inserted into the steering column extension. Fastener must go through the groove provided in the steering box shaft.
- 5) Install new fastening bolt along with the two washers and locknut as shown in fig.# 1 below.
- 6) Torque Fastener nut to 1.2 daNm (9 lbs/ft).
- 7) Replace carpeting around area of steering extension.
- 8) Check for binding in steering system. If there is binding, check system for faults.
- 9) Remove all protective covers from interior and insure that the area is clean.

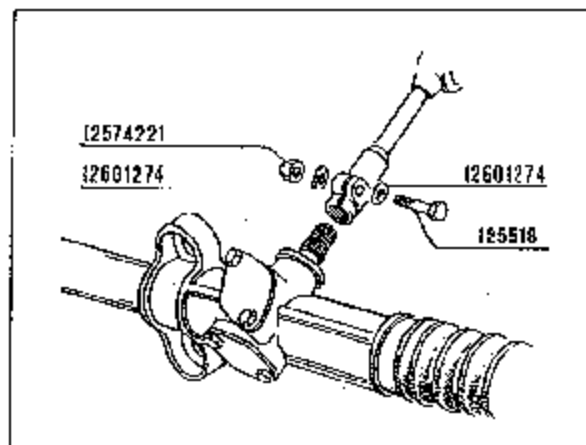

Fig.#1b

RECALL CLAIM FORM INSTRUCTIONS

FORWARD:

The enclosed recall claim form has been numbered in these areas to be completed by your dealership. The numbered areas indicate the necessary information needed to process the claim and promptly credit your account.

INSTRUCTIONS:

Information required to complete the recall claim form:

Area

Instructions

- 1) Enter your Ferrari 4-digit account number.
- 2) Enter vehicle mileage at time of repair.
- 3) Enter date of repair.
- 4) Enter Dealer claim calculations:
 - Parts Dealer Net
(Stock order price)
 - Parts Handling (33%)
 - Total Parts
 - Total Labor (hrs. x your approved WAR)
 - Amount Claimed
- 5) Enter name of authorized servicing Dealer.
- 6) Signature of Dealer or authorized designee.
- 7) Signature of vehicle's owner.
- 8) If VIN number listed in area 8 appears invalid, please show correct VIN in explanation space (9).

No repair order need be attached for the campaign unless an owner has lost or never received a recall claim form. If this occurs, record all pertinent data, as required by the recall claim form, on a repair order. **Owner signs the repair order.**

The repair order must not be submitted until the Ferrari Representative can provide a blank recall claim form. Transfer pertinent data from repair order to the recall claim form. In OWNER area (7), write "Owner's signature on repair order no. ." **Attach the repair order to the claim form** and submit for reimbursement.

MAILING:

Send the recall claim form to the Ferrari North America Warranty department in a Warranty claim return envelope (Part No. 3555).



NORTH AMERICA, INC.

DOCUMENT NUMBER FOR HISTORY USE ONLY

RECALL CAMPAIGN FORM

COPY #1 RETURN TO FACTORY		COPY #2 RETURN TO DEALER		COPY #3 PARTS COPY RETAIN WITH PARTS		COPY #4 FINAL TECHNICAL MANAGER	
OWNER:		SERV. O.R. ACCT. NO.	YR. VIN NO.	BELL O.R. ACCT. NO.	REPAIR DATE	WAVE CODE	RECALL CAMPAIGN NO.
OWNER'S SIGNATURE		①	⑧	③	②		
OWNER'S SIGNATURE				NO. /	HR.	MILEAGE	ALL RECALL CAMPAIGN WORK MUST BE ON AN APPROPRIATE RECALL CLAIM OR CLAIM FORM ATTACHED REPAIR ORDER COPY TO BACK
OWNER'S SIGNATURE						⑨	
OWNER'S SIGNATURE		WE CERTIFY THE COMPLETION OF REPAIRS, REQUISITES UNDER THE RECALL CAMPAIGN OF THIS VEHICLE		AUTHORIZED SERVING DEALER NAME		OPER. NO.	HOURS
OWNER'S SIGNATURE		AUTHORIZED SERVING DEALER NAME		SIGNATURE		DEALER CLAIM CALLED ACTIONS	
OWNER'S SIGNATURE		AUTHORIZED SERVING DEALER NAME		SIGNATURE		PARTS DEALER MET	
OWNER'S SIGNATURE		AUTHORIZED SERVING DEALER NAME		SIGNATURE		PARTS HANDLING	
OWNER'S SIGNATURE		AUTHORIZED SERVING DEALER NAME		SIGNATURE		TOTAL PARTS	
OWNER'S SIGNATURE		AUTHORIZED SERVING DEALER NAME		SIGNATURE		TOTAL LABOR	
OWNER'S SIGNATURE		AUTHORIZED SERVING DEALER NAME		SIGNATURE		SUBLET	
OWNER'S SIGNATURE		AUTHORIZED SERVING DEALER NAME		SIGNATURE		TOTAL	
OWNER'S SIGNATURE		AUTHORIZED SERVING DEALER NAME		SIGNATURE		AMOUNT CLAIMED	

Form No. 3740

Ferrari

Ferrari North America, Inc.
250 Sylvan Avenue
Englewood Cliffs, NJ 07632
201-818-2600
TLX: 8162616
FAX: 201-818-2626

September 1992

Letter "A"

This notice is sent to you in accordance with the requirements of the National Traffic and Motor Vehicles Safety Act.

Ferrari S.p.A., the manufacturer of Ferrari automobiles, has determined that certain defects exist in certain 1989 and 1990 model year Ferrari vehicles.



- 1) On 348 ts/tb vehicles with Vehicle Identification Number lower than 92208, the aluminum fittings on certain *fuel Injection lines* can corrode under extreme environmental conditions. Should such condition remain unnoticed, the result could be breakage of the aluminum fuel line fitting resulting in fuel leakage. As with any type of fuel system leakage, the possibility of a vehicle engine fire may exist.
- 2) On 348 ts/tb vehicles with Vehicle Identification Number lower than 86232, the *steering box extension fastener* was manufactured with a lower class of material and self-locking properties. This may result in a loss of tightening torque on the upper steering column fastener. Should such condition remain unnoticed and the use of the car be prolonged for an extensive period of time, loosening of the fastener could occur resulting in play in the steering system and consequential impairment of handling.

Since your car is among those potentially affected by the above conditions, we kindly ask you to contact any Ferrari Authorized Dealer immediately in order to arrange an inspection of your automobile, and if necessary, the Dealer will perform the required modifications.

The corrective action for the above listed repairs will be performed free of charge and will require approximately 1.5 hours, however please plan to leave your vehicle with the dealer all day to allow the dealer some flexibility for scheduling your repairs.

By the time you receive this letter, the Authorized Ferrari Dealer will have been supplied with the instructions and parts to perform the repairs.

Also, Ferrari S.p.A. has introduced a number of improvements into production that may be applicable to your vehicle. While your vehicle is at your Ferrari authorized dealer for the above listed recall campaign items, we would like the opportunity to extend these improvements to your car free of charge.

If the Dealer fails or is unable to make the necessary repairs free of charge within a reasonable time, you should inform the National Headquarters Office of Ferrari North America, Inc.

250 Sylvan Avenue,
Englewood Cliffs, NJ 07632
(201) 816-2651 (National Technical Office)
(201) 816-2652 (Customer Relations)



Although we urge you to immediately call one of the numbers indicated above, if the vehicle is not repaired free of charge or within a reasonable Time, you may also contact the Administrator of the National Traffic Safety Administration in Washington, D.C. 20590 or call the Auto Safety Hot line at 1-800-424-9393 nationally and (202) 366-0123 for Washington D.C. area residents.

We urge you to comply with this notice promptly and we apologize for any inconvenience this may cause you.

Sincerely,

A handwritten signature in black ink that reads "Kenneth McCay". The signature is written in a cursive style.

Kenneth McCay
Technical Director
Ferrari North America, Inc.

Ferrari

Ferrari North America, Inc.
250 Sylvan Avenue
Englewood Cliffs, NJ 07632
201-816-2600
TLX: 8162616
FAX: 201-816-2626

September 1992

Letter "B"

This notice is sent to you in accordance with the requirements of the National Traffic and Motor Vehicles Safety Act.

Ferrari S.p.A., the manufacturer of Ferrari automobiles, has determined that certain defects exist in certain 1990 model year Ferrari vehicles.



- 1) On 348 ts/tb vehicles with Vehicle Identification Number lower than 92208, the aluminum fittings on certain *fuel Injection lines* can corrode under extreme environmental conditions. Should such condition remain unnoticed, the result could be breakage of the aluminum fuel line fitting resulting in fuel leakage. As with any type of fuel system leakage, the possibility of a vehicle engine fire may exist.
- 2) On 348 ts/tb vehicles with Vehicle Identification Number lower than 87898, the *upper steering column locknut* was manufactured with a lower class of material and self-locking properties. This may result in a loss of tightening torque on the upper steering column fastener. Should such condition remain unnoticed and the use of the car be prolonged for an extensive period of time, loosening of the fastener could occur resulting in play in the steering system and consequential impairment of handling.
- 3) On 348 ts/tb vehicles with Vehicle Identification Number lower than 86232, the *steering box extension fastener* was manufactured with a lower class of material and self-locking properties. This may result in a loss of tightening torque on the steering box extension fastener. Should such condition remain unnoticed and the use of the car be prolonged for an extensive period of time, loosening of the fastener could occur resulting in play in the steering system and consequential impairment of handling.

Since your car is among those potentially affected by the above conditions, we kindly ask you to contact any Ferrari Authorized Dealer immediately in order to arrange an inspection of your automobile, and if necessary, the Dealer will perform the required modifications.

The corrective action for the above listed repairs will be performed free of charge and will require approximately 1.5 hours, however please plan to leave your vehicle with the dealer all day to allow the dealer some flexibility for scheduling your repairs.

Cont.....

By the time you receive this letter, the Authorized Ferrari Dealer will have been supplied with the instructions and parts to perform the repairs.

Also, Ferrari S.p.A. has introduced a number of improvements into production that may be applicable to your vehicle. While your vehicle is at your Ferrari authorized dealer for the above listed recall campaign items, we would like the opportunity to extend these improvements to your car free of charge.

If the Dealer fails or is unable to make the necessary repairs free of charge within a reasonable time, you should inform the National Headquarters Office of Ferrari North America, Inc.

250 Sylvan Avenue,
Englewood Cliffs, NJ 07632
(201) 816-2651 (National Technical Office)
(201) 816-2652 (Customer Relations)

Although we urge you to immediately call one of the numbers indicated above, if the vehicle is not repaired free of charge or within a reasonable Time, you may also contact the Administrator of the National Traffic Safety Administration in Washington, D.C. 20590 or call the Auto Safety Hot line at 1-800-424-9393 nationally and (202) 366-0123 for Washington D.C. area residents.

We urge you to comply with this notice promptly and we apologize for any inconvenience this may cause you.

Sincerely,



Kenneth McCay
Technical Director
Ferrari North America, Inc.



Ferrari

Ferrari North America, Inc.
250 Sylvan Avenue
Englewood Cliffs, NJ 07632
201-816-2600
TLX: 8162816
FAX: 201-816-2628

September 1992

Letter "C"

This notice is sent to you in accordance with the requirements of the National Traffic and Motor Vehicles Safety Act.



Ferrari S.p.A., the manufacturer of Ferrari automobiles, has determined that certain defects exist in certain 1990 model year Ferrari vehicles.

- 1) On 348 ts/tb vehicles with Vehicle Identification Number lower than 92208, the aluminum fittings on certain *fuel Injection lines* can corrode under extreme environmental conditions. Should such condition remain unnoticed, the result could be breakage of the aluminum fuel line fitting resulting in fuel leakage. As with any type of fuel system leakage, the possibility a vehicle engine fire may exist.
- 2) On 348 ts/tb vehicles with Vehicle Identification Number lower than 87898, the *upper steering column locknut* was manufactured with a lower class of material and self-locking properties. This may result in a loss of tightening torque on the upper steering column fastener. Should such condition remain unnoticed and the use of the car be prolonged for an extensive period of time, loosening of the fastener could occur resulting in play in the steering system and consequential impairment of handling.

Since your car is among those potentially affected by the above conditions, we kindly ask you to contact any Ferrari Authorized Dealer immediately in order to arrange an inspection of your automobile, and if necessary, the Dealer will perform the required modifications.

The corrective action for the above listed repairs will be performed free of charge and will require approximately 1.5 hours, however please plan to leave your vehicle with the dealer all day to allow the dealer some flexibility for scheduling your repairs.

By the time you receive this letter, the Authorized Ferrari Dealer will have been supplied with the instructions and parts to perform the repairs.

Also, Ferrari S.p.A. has introduced a number of improvements into production that may be applicable to your vehicle. While your vehicle is at your Ferrari authorized dealer for the above listed recall campaign items, we would like the opportunity to extend these improvements to your car free of charge.

If the Dealer fails or is unable to make the necessary repairs free of charge within a reasonable time, you should inform the National Headquarters Office of Ferrari North America, Inc.

250 Sylvan Avenue,
Englewood Cliffs, NJ 07632
(201) 816-2651 (National Technical Office)
(201) 816-2652 (Customer Relations)

Although we urge you to immediately call one of the numbers indicated above, if the vehicle is not repaired free of charge or within a reasonable Time, you may also contact the Administrator of the National Traffic Safety Administration in Washington, D.C. 20590 or call the Auto Safety Hot line at 1-800-424-9393 nationally and (202) 366-0123 for Washington D.C. area residents.

We urge you to comply with this notice promptly and we apologize for any inconvenience this may cause you.

Sincerely,



Kenneth McCay
Technical Director
Ferrari North America, Inc.



Ferrari

Ferrari North America, Inc.
250 Sylvan Avenue
Englewood Cliffs, NJ 07632
201-816-2600
TLX: 8162616
FAX: 201-816-2626

September 1992

Letter "D"

This notice is sent to you in accordance with the requirements of the National Traffic and Motor Vehicles Safety Act.



Ferrari S.p.A., the manufacturer of Ferrari automobiles, has determined that certain defects exist in certain 1990 and 1991 model year Ferrari vehicles.

On 348 ts/tb vehicles with Vehicle Identification Number lower than 87898, the *upper steering column locknut* was manufactured with a lower class of material and self-locking properties. This may result a loss of tightening torque on the *upper steering column fastener*. Should such condition remain unnoticed and the use of the car be prolonged for an extensive period of time, loosening of the fastener could occur resulting in play in the steering system and consequential impairment of handling.

Since your car is among those potentially affected by the above condition, we kindly ask you to contact any Ferrari Authorized Dealer immediately in order to arrange an inspection of your automobile, and, if necessary, the Dealer will perform the required modification.

The corrective action for the above listed repair will be performed free of charge and will require approximately 1.5 hours, however please plan to leave your vehicle with the dealer all day to allow the dealer some flexibility for scheduling your repairs.

By the time you receive this letter, the Authorized Ferrari Dealer will have been supplied with the instructions and parts to perform the repair.

Also, Ferrari S.p.A. has introduced a number of improvements into production that may be applicable to your vehicle. While your vehicle is at your Ferrari authorized dealer for the above listed recall campaign items, we would like the opportunity to extend these improvements to your car free of charge.

If the Dealer fails or is unable to make the necessary repairs free of charge within a reasonable time, you should inform the National Headquarters Office of Ferrari North America, Inc.

250 Sylvan Avenue,
Englewood Cliffs, NJ 07632
(201) 816-2651 (National Technical Office)
(201) 816-2652 (Customer Relations)

Although we urge you to immediately call one of the numbers indicated above, if the vehicle is not repaired free of charge or within a reasonable Time, you may also contact the Administrator of the National Traffic Safety Administration in Washington, D.C. 20590 or call the Auto Safety Hot line at 1-800-424-9393 nationally and (202) 366-0123 for Washington D.C. area residents.

We urge you to comply with this notice promptly and we apologize for any inconvenience this may cause you.

Sincerely,

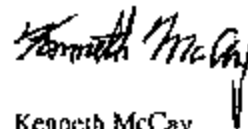

Kenneth McCay
Technical Director
Ferrari North America, Inc.



Ferrari

Ferrari North America, Inc.
250 Sylvan Avenue
Englewood Cliffs, NJ 07632
201-816-2600
TLX: 8162618
FAX: 201-816-2626

June 1992

Letter "E"



This notice is sent to you in accordance with the requirements of the National Traffic and Motor Vehicles Safety Act.

Ferrari S.p.A., the manufacturer of Ferrari automobiles, has determined that certain defects exist in certain 1990 and 1991 model year Ferrari vehicles.

On Testarossa vehicles with Vehicle Identification Number lower than 87483, the upper steering column locknut was manufactured with a lower class of material and self-locking properties. This result in a loss of tightening torque on the upper steering column fastener. Should such condition remain unnoticed and the use of the car be prolonged for an extensive period of time, loosening of fastener could occur resulting in play in the steering system and consequential impairment of handling.

Since your car is among those potentially affected by the above condition, we kindly ask you to contact any Ferrari Authorized Dealer immediately in order to arrange an inspection of your automobile, and if necessary, the Dealer will perform the required modification.

The corrective action for the above listed repair will be performed free of charge and will require approximately 1.5 hours, however please plan to leave your vehicle with the dealer all day to allow dealer some flexibility for scheduling your repair.

By the time you receive this letter, the Authorized Ferrari Dealer will have been supplied with the instructions and parts to perform the repair.

If the Dealer fails or is unable to make the necessary repair free of charge within a reasonable time, you should inform the National Headquarters Office of Ferrari North America, Inc.

250 Sylvan Avenue,
Englewood Cliffs, NJ 07632
(201) 816-2651 (National Technical Office)
(201) 816-2652 (Customer Relations)

Cont.....

Although we urge you to immediately call one of the numbers indicated above, if the vehicle is not repaired free of charge or within a reasonable Time, you may also contact the Administrator of the National Traffic Safety Administration in Washington, D.C. 20590 or call the Auto Safety Hot line at 1-800-424-9393 nationally and (202) 366-0123 for Washington D.C. area residents.

We urge you to comply with this notice promptly and we apologize for any inconvenience this may cause you.



Sincerely,

A handwritten signature in black ink that reads "Kenneth McCay". The signature is written in a cursive, slightly slanted style.

Kenneth McCay
Technical Director
Ferrari North America, Inc.

Ferrari

Ferrari North America, Inc.
250 Sylvan Avenue
Englewood Cliffs, NJ 07632
201-816-2600
FAX: 201-816-2626

September 1992

Letter "F"

This notice is sent to you in accordance with the requirements of the National Traffic and Motor Vehicles Safety Act.



Ferrari S.p.A., the manufacturer of Ferrari automobiles, has determined that certain defects exist in certain 1990 model year Ferrari vehicles.

On Mondial t coupe / cabriolet vehicles with Vehicle Identification Number lower than 92115, the aluminum fittings on certain *fuel Injection lines* can corrode under extreme environmental conditions. Should such condition remain unnoticed, the result could be breakage of the aluminum fuel line fittings resulting in fuel leakage. As with any type of fuel system leakage, the possibility of a vehicle engine fire may exist.

Since your car is among those potentially affected by the above condition, we kindly ask you to contact any Ferrari Authorized Dealer immediately in order to arrange an inspection of your automobile, and, if necessary, the Dealer will perform the required modification.

The corrective action for the above listed repair will be performed free of charge and will require approximately 1.5 hours, however please plan to leave your vehicle with the dealer all day to allow the dealer some flexibility for scheduling your repair.

By the time you receive this letter, the Authorized Ferrari Dealer will have been supplied with the instructions and parts to perform the repair.

If the Dealer fails or is unable to make the necessary repair free of charge within a reasonable time, you should inform the National Headquarters Office of Ferrari North America, Inc.

250 Sylvan Avenue,
Englewood Cliffs, NJ 07632
(201) 816-2651 (National Technical Office)
(201) 816-2652 (Customer Relations)

Cont.....

Although we urge you to immediately call one of the numbers indicated above, if the vehicle is not repaired free of charge or within a reasonable Time, you may also contact the Administrator of the National Traffic Safety Administration in Washington, D.C. 20590 or call the Auto Safety Hot line at 1-800-424-9393 nationally and (202) 366-0123 for Washington D.C. area residents.

We urge you to comply with this notice promptly and we apologize for any inconvenience this may cause you.

Sincerely,

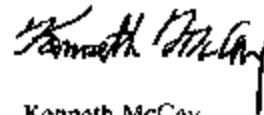

Kenneth McCay
Technical Director
Ferrari North America, Inc.



Ferrari

Ferrari North America, Inc.
250 Sylvan Avenue
Englewood Cliffs, NJ 07632
201-816-2600
FAX: 201-816-2628

September 1992

Letter "G"

This notice is sent to you in accordance with the requirements of the National Traffic and Motor Vehicles Safety Act.

Ferrari S.p.A., the manufacturer of Ferrari automobiles, has determined that certain defects exist in certain 1990 model year Ferrari vehicles.



- 1) On Mondial t coupe / cabriolet vehicles with Vehicle Identification Number lower than 92111, the aluminum fittings on certain *fuel injection lines* can corrode under extreme environmental conditions. Should such condition remain unnoticed, the result could be breakage of the aluminum fuel line fitting resulting in fuel leakage. As with any type of fuel system leakage, the possibility of a vehicle engine fire may exist.
- 2) On Mondial t coupe / cabriolet vehicles with Vehicle Identification Number lower than 87908, the *upper steering column locknut* was manufactured with a lower class of material and self-locking properties. This may result in a loss of tightening torque on the upper steering column fastener. Should such condition remain unnoticed and the use of the car be prolonged for an extensive period of time, loosening of the fastener could occur resulting in play in the steering system and consequential impairment of handling.

Since your car is among those potentially affected by the above conditions, we kindly ask you to contact any Ferrari Authorized Dealer immediately in order to arrange an inspection of your automobile, and if necessary, the Dealer will perform the required modifications.

The corrective action for the above listed repairs will be performed free of charge and will require approximately 1.5 hours, however please plan to leave your vehicle with the dealer all day to allow the dealer some flexibility for scheduling your repairs.

By the time you receive this letter, the Authorized Ferrari Dealer will have been supplied with the instructions and parts to perform the repairs.

If the Dealer fails or is unable to make the necessary repairs free of charge within a reasonable time, you should inform the National Headquarters Office of Ferrari North America, Inc.

250 Sylvan Avenue,
Englewood Cliffs, NJ 07632
(201) 816-2651 (National Technical Office)
(201) 816-2652 (Customer Relations)

Although we urge you to immediately call one of the numbers indicated above, if the vehicle is not repaired free of charge or within a reasonable Time, you may also contact the Administrator of the National Traffic Safety Administration in Washington, D.C. 20590 or call the Auto Safety Hot line at 1-800-424-9393 nationally and (202) 366-0123 for Washington D.C. area residents.

We urge you to comply with this notice promptly and we apologize for any inconvenience this may cause you.

Sincerely,

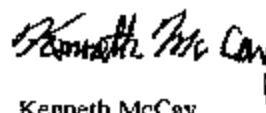

Kenneth McCay
Technical Director
Ferrari North America, Inc.



Ferrari

Ferrari North America, Inc.
250 Sylvan Avenue
Englewood Cliffs, NJ 07632
201-816-2600
FAX: 201-816-2626

September 1992

Letter "H"

This notice is sent to you in accordance with the requirements of the National Traffic and Motor Vehicles Safety Act.

Ferrari S.p.A., the manufacturer of Ferrari automobiles, has determined that certain defects exist in certain 1990 and 1991 model year Ferrari vehicles.

On 348 ts/tb vehicles with Vehicle Identification Number lower than 92208, the aluminum fittings on certain *fuel Injection lines* can corrode under extreme environmental conditions. Should such condition remain unnoticed, the result could be breakage of the aluminum fuel line fitting resulting in fuel leakage. As with any type of fuel system leakage, the possibility of a vehicle engine fire may exist.

Since your car is among those potentially affected by the above condition, we kindly ask you to contact any Ferrari Authorized Dealer immediately in order to arrange an inspection of your automobile, and if necessary, the Dealer will perform the required modification.

The corrective action for the above listed repair will be performed free of charge and will require approximately 1.5 hours, however please plan to leave your vehicle with the dealer all day to allow the dealer some flexibility for scheduling your repairs.

By the time you receive this letter, the Authorized Ferrari Dealer will have been supplied with the instructions and parts to perform the repair.

Also, Ferrari S.p.A. has introduced a number of improvements into production that may be applicable to your vehicle. While your vehicle is at your Ferrari authorized dealer for the above listed recall campaign items, we would like the opportunity to extend these improvements to your car free of charge.



If the Dealer fails or is unable to make the necessary repairs free of charge within a reasonable time, you should inform the National Headquarters Office of Ferrari North America, Inc.

250 Sylvan Avenue,
Englewood Cliffs, NJ 07632
(201) 816-2651 (National Technical Office)
(201) 816-2652 (Customer Relations)

Although we urge you to immediately call one of the numbers indicated above, if the vehicle is not repaired free of charge or within a reasonable Time, you may also contact the Administrator of the National Traffic Safety Administration in Washington, D.C. 20590 or call the Auto Safety Hot line at 1-800-424-9393 nationally and (202) 366-0123 for Washington D.C. area residents.

We urge you to comply with this notice promptly and we apologize for any inconvenience this may cause you.

Sincerely,

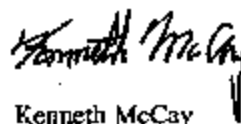

Kenneth McCay
Technical Director
Ferrari North America, Inc.



VEHICLE MASTER LIST

1989 348 ts / tb

<u>Serial Number</u>	<u>Model</u>	<u>Year</u>	<u>Letter</u>	<u>Recall #147</u>	<u>Recall #148</u>	<u>Recall #149</u>
82277	ts	89	"A"	Yes	No	Yes
82281	ts	89	"A"	Yes	No	Yes
82292	ts	89	"A"	Yes	No	Yes
82301	ts	89	"A"	Yes	No	Yes
82311	ts	89	"A"	Yes	No	Yes
82314	ts	89	"A"	Yes	No	Yes
82321	ts	89	"A"	Yes	No	Yes
82325	ts	89	"A"	Yes	No	Yes
82330	ts	89	"A"	Yes	No	Yes
82333	ts	89	"A"	Yes	No	Yes
82337	ts	89	"A"	Yes	No	Yes
82347	tb	89	"A"	Yes	No	Yes
82353	tb	89	"A"	Yes	No	Yes
82360	tb	89	"A"	Yes	No	Yes
82365	tb	89	"A"	Yes	No	Yes
82371	tb	89	"A"	Yes	No	Yes
82375	tb	89	"A"	Yes	No	Yes
82386	tb	89	"A"	Yes	No	Yes
82391	ts	89	"A"	Yes	No	Yes
82395	tb	89	"A"	Yes	No	Yes
82399	ts	89	"A"	Yes	No	Yes
82407	tb	89	"A"	Yes	No	Yes
82414	ts	89	"A"	Yes	No	Yes
82418	tb	89	"A"	Yes	No	Yes
82426	tb	89	"A"	Yes	No	Yes
82436	ts	89	"A"	Yes	No	Yes
82449	tb	89	"A"	Yes	No	Yes
82453	ts	89	"A"	Yes	No	Yes
82460	tb	89	"A"	Yes	No	Yes
82464	tb	89	"A"	Yes	No	Yes
82468	ts	89	"A"	Yes	No	Yes
82535	tb	89	"A"	Yes	No	Yes
82536	ts	89	"A"	Yes	No	Yes
82538	ts	89	"A"	Yes	No	Yes
82541	ts	89	"A"	Yes	No	Yes
82545	tb	89	"A"	Yes	No	Yes
82555	ts	89	"A"	Yes	No	Yes
82557	ts	89	"A"	Yes	No	Yes
82561	ts	89	"A"	Yes	No	Yes
82565	ts	89	"A"	Yes	No	Yes
82569	ts	89	"A"	Yes	No	Yes
82576	ts	89	"A"	Yes	No	Yes
82578	tb	89	"A"	Yes	No	Yes
82585	ts	89	"A"	Yes	No	Yes
82589	ts	89	"A"	Yes	No	Yes
82590	ts	89	"A"	Yes	No	Yes
82591	ts	89	"A"	Yes	No	Yes
82592	tb	89	"A"	Yes	No	Yes
82593	ts	89	"A"	Yes	No	Yes
82594	ts	89	"A"	Yes	No	Yes

<u>Serial Number</u>	<u>Model</u>	<u>Year</u>	<u>Letter</u>	<u>Recall #147</u>	<u>Recall #148</u>	<u>Recall #149</u>
82595	ts	89	"A"	Yes	No	Yes
82596	ts	89	"A"	Yes	No	Yes
82597	ts	89	"A"	Yes	No	Yes
82598	tb	89	"A"	Yes	No	Yes
82599	ts	89	"A"	Yes	No	Yes
82600	ts	89	"A"	Yes	No	Yes
82601	ts	89	"A"	Yes	No	Yes
82607	ts	89	"A"	Yes	No	Yes
82608	ts	89	"A"	Yes	No	Yes
82609	ts	89	"A"	Yes	No	Yes
82610	ts	89	"A"	Yes	No	Yes
82611	ts	89	"A"	Yes	No	Yes
82612	ts	89	"A"	Yes	No	Yes
82613	ts	89	"A"	Yes	No	Yes
82614	ts	89	"A"	Yes	No	Yes
82615	ts	89	"A"	Yes	No	Yes
82616	ts	89	"A"	Yes	No	Yes
82617	ts	89	"A"	Yes	No	Yes
82618	ts	89	"A"	Yes	No	Yes
82619	ts	89	"A"	Yes	No	Yes
82620	ts	89	"A"	Yes	No	Yes
82621	ts	89	"A"	Yes	No	Yes
82629	ts	89	"A"	Yes	No	Yes
82630	ts	89	"A"	Yes	No	Yes
82631	ts	89	"A"	Yes	No	Yes
82632	ts	89	"A"	Yes	No	Yes
82633	ts	89	"A"	Yes	No	Yes
82634	tb	89	"A"	Yes	No	Yes
82635	ts	89	"A"	Yes	No	Yes
82636	ts	89	"A"	Yes	No	Yes
82637	ts	89	"A"	Yes	No	Yes
82638	ts	89	"A"	Yes	No	Yes
82639	tb	89	"A"	Yes	No	Yes
82640	ts	89	"A"	Yes	No	Yes
82641	ts	89	"A"	Yes	No	Yes
82642	ts	89	"A"	Yes	No	Yes
82643	ts	89	"A"	Yes	No	Yes
82651	ts	89	"A"	Yes	No	Yes
82652	ts	89	"A"	Yes	No	Yes
82653	ts	89	"A"	Yes	No	Yes
82654	ts	89	"A"	Yes	No	Yes
82655	ts	89	"A"	Yes	No	Yes
82656	ts	89	"A"	Yes	No	Yes
82657	ts	89	"A"	Yes	No	Yes
82658	ts	89	"A"	Yes	No	Yes
82659	ts	89	"A"	Yes	No	Yes
82660	ts	89	"A"	Yes	No	Yes
82661	ts	89	"A"	Yes	No	Yes
82662	ts	89	"A"	Yes	No	Yes
82663	ts	89	"A"	Yes	No	Yes
82664	ts	89	"A"	Yes	No	Yes

<u>Serial Number</u>	<u>Model</u>	<u>Year</u>	<u>Letter</u>	<u>Recall #147</u>	<u>Recall #148</u>	<u>Recall #149</u>
82665	ts	89	" A "	Yes	No	Yes
82673	tb	89	" A "	Yes	No	Yes
82674	ts	89	" A "	Yes	No	Yes
82675	ts	89	" A "	Yes	No	Yes
82676	ts	89	" A "	Yes	No	Yes
82677	tb	89	" A "	Yes	No	Yes
82678	ts	89	" A "	Yes	No	Yes
82679	ts	89	" A "	Yes	No	Yes
82680	tb	89	" A "	Yes	No	Yes
82681	ts	89	" A "	Yes	No	Yes
82682	tb	89	" A "	Yes	No	Yes
82683	ts	89	" A "	Yes	No	Yes
82684	ts	89	" A "	Yes	No	Yes
82685	tb	89	" A "	Yes	No	Yes
82686	ts	89	" A "	Yes	No	Yes
82687	ts	89	" A "	Yes	No	Yes
84107	tb	89	" A "	Yes	No	Yes
84108	tb	89	" A "	Yes	No	Yes
84124	tb	89	" A "	Yes	No	Yes
84125	tb	89	" A "	Yes	No	Yes
84141	tb	89	" A "	Yes	No	Yes
84142	tb	89	" A "	Yes	No	Yes
84157	tb	89	" A "	Yes	No	Yes
84158	tb	89	" A "	Yes	No	Yes
84171	tb	89	" A "	Yes	No	Yes
84172	tb	89	" A "	Yes	No	Yes
84186	tb	89	" A "	Yes	No	Yes
84187	tb	89	" A "	Yes	No	Yes
84206	tb	89	" A "	Yes	No	Yes
84207	tb	89	" A "	Yes	No	Yes
84219	tb	89	" A "	Yes	No	Yes
84220	tb	89	" A "	Yes	No	Yes
84235	tb	89	" A "	Yes	No	Yes

**1989 vehicles
affected:**

134

0

134

1990 348 ts / tb

<u>Serial Number</u>	<u>Model</u>	<u>Year</u>	<u>Letter</u>	<u>Recall #147</u>	<u>Recall #148</u>	<u>Recall #149</u>
84547	ts	90	"A"	Yes	No	Yes
84548	ts	90	"A"	Yes	No	Yes
84561	ts	90	"A"	Yes	No	Yes
84582	ts	90	"A"	Yes	No	Yes
84583	ts	90	"A"	Yes	No	Yes
84564	ts	90	"A"	Yes	No	Yes
84805	ts	90	"A"	Yes	No	Yes
85389	ts	90	"B"	Yes	Yes	Yes
85406	ts	90	"B"	Yes	Yes	Yes
85407	ts	90	"B"	Yes	Yes	Yes
85427	ts	90	"B"	Yes	Yes	Yes
85446	ts	90	"B"	Yes	Yes	Yes
85466	ts	90	"B"	Yes	Yes	Yes
85486	ts	90	"B"	Yes	Yes	Yes
85506	ts	90	"B"	Yes	Yes	Yes
85882	ts	90	"B"	Yes	Yes	Yes
85893	ts	90	"B"	Yes	Yes	Yes
85912	ts	90	"B"	Yes	Yes	Yes
85929	ts	90	"B"	Yes	Yes	Yes
85930	ts	90	"B"	Yes	Yes	Yes
85950	ts	90	"B"	Yes	Yes	Yes
85969	ts	90	"B"	Yes	Yes	Yes
85970	ts	90	"B"	Yes	Yes	Yes
85987	ts	90	"B"	Yes	Yes	Yes
86006	ts	90	"B"	Yes	Yes	Yes
86007	ts	90	"B"	Yes	Yes	Yes
86024	ts	90	"B"	Yes	Yes	Yes
86043	ts	90	"B"	Yes	Yes	Yes
86044	ts	90	"B"	Yes	Yes	Yes
86048	ts	90	"B"	Yes	Yes	Yes
86049	ts	90	"B"	Yes	Yes	Yes
86062	ts	90	"B"	Yes	Yes	Yes
86068	ts	90	"B"	Yes	Yes	Yes
86086	ts	90	"B"	Yes	Yes	Yes
86087	ts	90	"B"	Yes	Yes	Yes
86104	ts	90	"B"	Yes	Yes	Yes
86105	ts	90	"B"	Yes	Yes	Yes
86123	ts	90	"B"	Yes	Yes	Yes
86141	ts	90	"B"	Yes	Yes	Yes
86142	ts	90	"B"	Yes	Yes	Yes
86160	ts	90	"B"	Yes	Yes	Yes
86161	ts	90	"B"	Yes	Yes	Yes
86162	ts	90	"B"	Yes	Yes	Yes
86178	ts	90	"B"	Yes	Yes	Yes
86196	ts	90	"B"	Yes	Yes	Yes
86197	ts	90	"B"	Yes	Yes	Yes
86211	ts	90	"B"	Yes	Yes	Yes
86212	ts	90	"B"	Yes	Yes	Yes

<u>Serial Number</u>	<u>Model</u>	<u>Year</u>	<u>Letter</u>	<u>Recall #147</u>	<u>Recall #148</u>	<u>Recall #149</u>
86232	ts	90	"C"	Yes	Yes	No
86238	ts	90	"C"	Yes	Yes	No
86239	ts	90	"C"	Yes	Yes	No
86253	ts	90	"C"	Yes	Yes	No
86254	ts	90	"C"	Yes	Yes	No
86255	ts	90	"C"	Yes	Yes	No
86273	ts	90	"C"	Yes	Yes	No
86274	ts	90	"C"	Yes	Yes	No
86275	ts	90	"C"	Yes	Yes	No
86276	ts	90	"C"	Yes	Yes	No
86291	ts	90	"C"	Yes	Yes	No
86292	ts	90	"C"	Yes	Yes	No
86293	ts	90	"C"	Yes	Yes	No
86294	ts	90	"C"	Yes	Yes	No
86310	ts	90	"C"	Yes	Yes	No
86312	ts	90	"C"	Yes	Yes	No
86313	ts	90	"C"	Yes	Yes	No
86314	ts	90	"C"	Yes	Yes	No
86340	ts	90	"C"	Yes	Yes	No
86350	ts	90	"C"	Yes	Yes	No
86380	ts	90	"C"	Yes	Yes	No
86383	ts	90	"C"	Yes	Yes	No
86389	ts	90	"C"	Yes	Yes	No
86410	ts	90	"C"	Yes	Yes	No
86424	ts	90	"C"	Yes	Yes	No
86425	ts	90	"C"	Yes	Yes	No
86426	ts	90	"C"	Yes	Yes	No
86427	ts	90	"C"	Yes	Yes	No
86428	ts	90	"C"	Yes	Yes	No
86429	ts	90	"C"	Yes	Yes	No
86430	ts	90	"C"	Yes	Yes	No
86443	ts	90	"C"	Yes	Yes	No
86444	ts	90	"C"	Yes	Yes	No
86445	ts	90	"C"	Yes	Yes	No
86446	ts	90	"C"	Yes	Yes	No
86447	ts	90	"C"	Yes	Yes	No
86464	ts	90	"C"	Yes	Yes	No
86465	ts	90	"C"	Yes	Yes	No
86466	ts	90	"C"	Yes	Yes	No
86467	ts	90	"C"	Yes	Yes	No
86488	ts	90	"C"	Yes	Yes	No
86481	ts	90	"C"	Yes	Yes	No
86487	ts	90	"C"	Yes	Yes	No
86483	ts	90	"C"	Yes	Yes	No
86484	ts	90	"C"	Yes	Yes	No
86485	ts	90	"C"	Yes	Yes	No
86501	ts	90	"C"	Yes	Yes	No
86502	ts	90	"C"	Yes	Yes	No
86503	ts	90	"C"	Yes	Yes	No
86504	ts	90	"C"	Yes	Yes	No
86507	ts	90	"C"	Yes	Yes	No

<u>Serial Number</u>	<u>Model</u>	<u>Year</u>	<u>Letter</u>	<u>Recall #147</u>	<u>Recall #148</u>	<u>Recall #149</u>
86521	ts	90	"C"	Yes	Yes	No
86522	ts	90	"C"	Yes	Yes	No
86523	ts	90	"C"	Yes	Yes	No
86524	ts	90	"C"	Yes	Yes	No
86538	ts	90	"C"	Yes	Yes	No
86540	ts	90	"C"	Yes	Yes	No
86541	ts	90	"C"	Yes	Yes	No
86542	ts	90	"C"	Yes	Yes	No
86556	ts	90	"C"	Yes	Yes	No
86557	ts	90	"C"	Yes	Yes	No
86558	ts	90	"C"	Yes	Yes	No
86559	ts	90	"C"	Yes	Yes	No
86563	ts	90	"C"	Yes	Yes	No
86573	ts	90	"C"	Yes	Yes	No
86574	ts	90	"C"	Yes	Yes	No
86575	ts	90	"C"	Yes	Yes	No
86576	ts	90	"C"	Yes	Yes	No
86592	ts	90	"C"	Yes	Yes	No
86593	ts	90	"C"	Yes	Yes	No
86594	ts	90	"C"	Yes	Yes	No
86595	ts	90	"C"	Yes	Yes	No
86612	ts	90	"C"	Yes	Yes	No
86613	ts	90	"C"	Yes	Yes	No
86614	ts	90	"C"	Yes	Yes	No
86615	ts	90	"C"	Yes	Yes	No
86616	ts	90	"C"	Yes	Yes	No
86630	ts	90	"C"	Yes	Yes	No
86631	ts	90	"C"	Yes	Yes	No
86632	ts	90	"C"	Yes	Yes	No
86633	ts	90	"C"	Yes	Yes	No
86634	ts	90	"C"	Yes	Yes	No
86639	ts	90	"C"	Yes	Yes	No
86649	ts	90	"C"	Yes	Yes	No
86650	ts	90	"C"	Yes	Yes	No
86651	ts	90	"C"	Yes	Yes	No
86652	ts	90	"C"	Yes	Yes	No
86653	ts	90	"C"	Yes	Yes	No
86668	ts	90	"C"	Yes	Yes	No
86669	ts	90	"C"	Yes	Yes	No
86670	ts	90	"C"	Yes	Yes	No
86671	ts	90	"C"	Yes	Yes	No
86672	ts	90	"C"	Yes	Yes	No
86673	ts	90	"C"	Yes	Yes	No
86674	ts	90	"C"	Yes	Yes	No
86675	ts	90	"C"	Yes	Yes	No
86689	ts	90	"C"	Yes	Yes	No
86690	ts	90	"C"	Yes	Yes	No
86691	ts	90	"C"	Yes	Yes	No
86692	ts	90	"C"	Yes	Yes	No
86693	ts	90	"C"	Yes	Yes	No
86694	ts	90	"C"	Yes	Yes	No

<u>Serial Number</u>	<u>Model</u>	<u>Year</u>	<u>Letter</u>	<u>Recall #147</u>	<u>Recall #148</u>	<u>Recall #149</u>
86695	TS	90	"C"	Yes	Yes	No
86696	TS	90	"C"	Yes	Yes	No
86706	TS	90	"C"	Yes	Yes	No
86716	TS	90	"C"	Yes	Yes	No
86717	TS	90	"C"	Yes	Yes	No
86718	TS	90	"C"	Yes	Yes	No
86719	TS	90	"C"	Yes	Yes	No
86720	TS	90	"C"	Yes	Yes	No
86721	TS	90	"C"	Yes	Yes	No
86722	TS	90	"C"	Yes	Yes	No
86723	TS	90	"C"	Yes	Yes	No
86724	TS	90	"C"	Yes	Yes	No
86735	TS	90	"C"	Yes	Yes	No
86736	TS	90	"C"	Yes	Yes	No
86754	TS	90	"C"	Yes	Yes	No
86772	TS	90	"C"	Yes	Yes	No
86773	TS	90	"C"	Yes	Yes	No
86781	TS	90	"C"	Yes	Yes	No
86853	TS	90	"C"	Yes	Yes	No
86854	TS	90	"C"	Yes	Yes	No
86857	TS	90	"C"	Yes	Yes	No
86869	TS	90	"C"	Yes	Yes	No
86870	TS	90	"C"	Yes	Yes	No
86871	TS	90	"C"	Yes	Yes	No
86872	TS	90	"C"	Yes	Yes	No
86874	TS	90	"C"	Yes	Yes	No
86888	TS	90	"C"	Yes	Yes	No
86889	TS	90	"C"	Yes	Yes	No
86890	TS	90	"C"	Yes	Yes	No
86891	TS	90	"C"	Yes	Yes	No
86906	TS	90	"C"	Yes	Yes	No
86907	TS	90	"C"	Yes	Yes	No
86908	TS	90	"C"	Yes	Yes	No
86909	TS	90	"C"	Yes	Yes	No
86910	TS	90	"C"	Yes	Yes	No
86912	TS	90	"C"	Yes	Yes	No
86913	TS	90	"C"	Yes	Yes	No
86925	TS	90	"C"	Yes	Yes	No
86926	TS	90	"C"	Yes	Yes	No
86927	TS	90	"C"	Yes	Yes	No
86928	TS	90	"C"	Yes	Yes	No
86933	TS	90	"C"	Yes	Yes	No
86946	TS	90	"C"	Yes	Yes	No
86947	TS	90	"C"	Yes	Yes	No
86948	TS	90	"C"	Yes	Yes	No
86949	TS	90	"C"	Yes	Yes	No
86963	TS	90	"C"	Yes	Yes	No
86964	TS	90	"C"	Yes	Yes	No
86965	TS	90	"C"	Yes	Yes	No
86966	TS	90	"C"	Yes	Yes	No
86970	TS	90	"C"	Yes	Yes	No

<u>Serial Number</u>	<u>Model</u>	<u>Year</u>	<u>Letter</u>	<u>Recall #147</u>	<u>Recall #148</u>	<u>Recall #149</u>
87077	ts	90	"C"	Yes	Yes	No
87078	ts	90	"C"	Yes	Yes	No
87079	ts	90	"C"	Yes	Yes	No
87080	ts	90	"C"	Yes	Yes	No
87081	ts	90	"C"	Yes	Yes	No
87091	ts	90	"C"	Yes	Yes	No
87092	ts	90	"C"	Yes	Yes	No
87093	ts	90	"C"	Yes	Yes	No
87094	ts	90	"C"	Yes	Yes	No
87108	ts	90	"C"	Yes	Yes	No
87109	ts	90	"C"	Yes	Yes	No
87110	ts	90	"C"	Yes	Yes	No
87111	ts	90	"C"	Yes	Yes	No
87112	ts	90	"C"	Yes	Yes	No
87124	ts	90	"C"	Yes	Yes	No
87125	ts	90	"C"	Yes	Yes	No
87126	ts	90	"C"	Yes	Yes	No
87127	ts	90	"C"	Yes	Yes	No
87145	ts	90	"C"	Yes	Yes	No
87146	ts	90	"C"	Yes	Yes	No
87147	ts	90	"C"	Yes	Yes	No
87151	ts	90	"C"	Yes	Yes	No
87152	ts	90	"C"	Yes	Yes	No
87167	ts	90	"C"	Yes	Yes	No
87168	ts	90	"C"	Yes	Yes	No
87169	ts	90	"C"	Yes	Yes	No
87170	ts	90	"C"	Yes	Yes	No
87171	ts	90	"C"	Yes	Yes	No
87173	ts	90	"C"	Yes	Yes	No
87188	ts	90	"C"	Yes	Yes	No
87189	ts	90	"C"	Yes	Yes	No
87190	ts	90	"C"	Yes	Yes	No
87206	ts	90	"C"	Yes	Yes	No
87207	ts	90	"C"	Yes	Yes	No
87208	ts	90	"C"	Yes	Yes	No
87209	ts	90	"C"	Yes	Yes	No
87210	ts	90	"C"	Yes	Yes	No
87228	ts	90	"C"	Yes	Yes	No
87227	ts	90	"C"	Yes	Yes	No
87228	ts	90	"C"	Yes	Yes	No
87229	ts	90	"C"	Yes	Yes	No
87244	ts	90	"C"	Yes	Yes	No
87245	ts	90	"C"	Yes	Yes	No
87246	ts	90	"C"	Yes	Yes	No
87247	ts	90	"C"	Yes	Yes	No
87248	ts	90	"C"	Yes	Yes	No
87264	ts	90	"C"	Yes	Yes	No
87265	ts	90	"C"	Yes	Yes	No
87266	ts	90	"C"	Yes	Yes	No
87267	ts	90	"C"	Yes	Yes	No
87282	ts	90	"C"	Yes	Yes	No

<u>Serial Number</u>	<u>Model</u>	<u>Year</u>	<u>Letter</u>	<u>Recall #147</u>	<u>Recall #148</u>	<u>Recall #149</u>
87283	ts	90	"C"	Yes	Yes	No
87284	ts	90	"C"	Yes	Yes	No
87285	ts	90	"C"	Yes	Yes	No
87286	ts	90	"C"	Yes	Yes	No
87301	ts	90	"C"	Yes	Yes	No
87302	ts	90	"C"	Yes	Yes	No
87303	ts	90	"C"	Yes	Yes	No
87319	ts	90	"C"	Yes	Yes	No
87320	ts	90	"C"	Yes	Yes	No
87321	ts	90	"C"	Yes	Yes	No
87322	ts	90	"C"	Yes	Yes	No
87339	ts	90	"C"	Yes	Yes	No
87340	ts	90	"C"	Yes	Yes	No
87341	ts	90	"C"	Yes	Yes	No
87342	ts	90	"C"	Yes	Yes	No
87357	ts	90	"C"	Yes	Yes	No
87358	ts	90	"C"	Yes	Yes	No
87359	ts	90	"C"	Yes	Yes	No
87360	ts	90	"C"	Yes	Yes	No
87378	ts	90	"C"	Yes	Yes	No
87379	ts	90	"C"	Yes	Yes	No
87380	ts	90	"C"	Yes	Yes	No
87381	ts	90	"C"	Yes	Yes	No
87396	ts	90	"C"	Yes	Yes	No
87397	ts	90	"C"	Yes	Yes	No
87398	ts	90	"C"	Yes	Yes	No
87413	ts	90	"C"	Yes	Yes	No
87414	ts	90	"C"	Yes	Yes	No
87415	ts	90	"C"	Yes	Yes	No
87416	ts	90	"C"	Yes	Yes	No
87431	ts	90	"C"	Yes	Yes	No
87432	ts	90	"C"	Yes	Yes	No
87433	ts	90	"C"	Yes	Yes	No
87434	ts	90	"C"	Yes	Yes	No
87450	ts	90	"C"	Yes	Yes	No
87451	ts	90	"C"	Yes	Yes	No
87452	ts	90	"C"	Yes	Yes	No
87468	ts	90	"C"	Yes	Yes	No
87469	ts	90	"C"	Yes	Yes	No
87470	ts	90	"C"	Yes	Yes	No
87471	ts	90	"C"	Yes	Yes	No
87487	ts	90	"C"	Yes	Yes	No
87488	ts	90	"C"	Yes	Yes	No
87489	ts	90	"C"	Yes	Yes	No
87490	ts	90	"C"	Yes	Yes	No
87506	ts	90	"C"	Yes	Yes	No
87507	ts	90	"C"	Yes	Yes	No
87508	ts	90	"C"	Yes	Yes	No
87509	ts	90	"C"	Yes	Yes	No
87525	ts	90	"C"	Yes	Yes	No
87526	ts	90	"C"	Yes	Yes	No

<u>Serial Number</u>	<u>Model</u>	<u>Year</u>	<u>Letter</u>	<u>Recall #147</u>	<u>Recall #148</u>	<u>Recall #149</u>
87527	ts	90	"C"	Yes	Yes	No
87528	ts	90	"C"	Yes	Yes	No
87544	ts	90	"C"	Yes	Yes	No
87545	ts	90	"C"	Yes	Yes	No
87546	ts	90	"C"	Yes	Yes	No
87547	ts	90	"C"	Yes	Yes	No
87563	ts	90	"C"	Yes	Yes	No
87564	ts	90	"C"	Yes	Yes	No
87565	ts	90	"C"	Yes	Yes	No
87566	ts	90	"C"	Yes	Yes	No
87572	tb	90	"C"	Yes	Yes	No
87573	tb	90	"C"	Yes	Yes	No
87574	tb	90	"C"	Yes	Yes	No
87575	tb	90	"C"	Yes	Yes	No
87582	ts	90	"C"	Yes	Yes	No
87583	ts	90	"C"	Yes	Yes	No
87584	ts	90	"C"	Yes	Yes	No
87585	ts	90	"C"	Yes	Yes	No
87604	ts	90	"C"	Yes	Yes	No
87605	ts	90	"C"	Yes	Yes	No
87606	ts	90	"C"	Yes	Yes	No
87607	ts	90	"C"	Yes	Yes	No
87622	tb	90	"C"	Yes	Yes	No
87623	ts	90	"C"	Yes	Yes	No
87624	ts	90	"C"	Yes	Yes	No
87625	ts	90	"C"	Yes	Yes	No
87626	ts	90	"C"	Yes	Yes	No
87641	ts	90	"C"	Yes	Yes	No
87642	ts	90	"C"	Yes	Yes	No
87643	ts	90	"C"	Yes	Yes	No
87644	ts	90	"C"	Yes	Yes	No
87660	ts	90	"C"	Yes	Yes	No
87661	ts	90	"C"	Yes	Yes	No
87662	ts	90	"C"	Yes	Yes	No
87663	ts	90	"C"	Yes	Yes	No
87679	ts	90	"C"	Yes	Yes	No
87680	ts	90	"C"	Yes	Yes	No
87681	ts	90	"C"	Yes	Yes	No
87682	ts	90	"C"	Yes	Yes	No
87698	ts	90	"C"	Yes	Yes	No
87699	ts	90	"C"	Yes	Yes	No
87700	ts	90	"C"	Yes	Yes	No
87701	ts	90	"C"	Yes	Yes	No
87718	ts	90	"C"	Yes	Yes	No
87719	ts	90	"C"	Yes	Yes	No
87720	ts	90	"C"	Yes	Yes	No
87721	ts	90	"C"	Yes	Yes	No
87736	ts	90	"C"	Yes	Yes	No
87737	ts	90	"C"	Yes	Yes	No
87738	ts	90	"C"	Yes	Yes	No
87739	ts	90	"C"	Yes	Yes	No

<u>Serial Number</u>	<u>Model</u>	<u>Year</u>	<u>Letter</u>	<u>Recall #147</u>	<u>Recall #148</u>	<u>Recall #149</u>
87755	ts	90	"C"	Yes	Yes	No
87756	ts	90	"C"	Yes	Yes	No
87757	ts	90	"C"	Yes	Yes	No
87774	ts	90	"C"	Yes	Yes	No
87775	ts	90	"C"	Yes	Yes	No
87776	ts	90	"C"	Yes	Yes	No
87793	ts	90	"C"	Yes	Yes	No
87794	ts	90	"C"	Yes	Yes	No
87795	ts	90	"C"	Yes	Yes	No
87812	ts	90	"C"	Yes	Yes	No
87813	ts	90	"C"	Yes	Yes	No
87814	ts	90	"C"	Yes	Yes	No
87815	ts	90	"C"	Yes	Yes	No
87831	ts	90	"C"	Yes	Yes	No
87832	ts	90	"C"	Yes	Yes	No
87833	ts	90	"C"	Yes	Yes	No
87834	ts	90	"C"	Yes	Yes	No
87876	ts	90	"C"	Yes	Yes	No
87877	ts	90	"C"	Yes	Yes	No
87878	ts	90	"C"	Yes	Yes	No
87879	ts	90	"C"	Yes	Yes	No
87880	ts	90	"C"	Yes	Yes	No
87888	ts	90	"C"	Yes	Yes	No
87966	ts	90	"D"	Yes	Yes	No
88050	ts	90	"D"	Yes	Yes	No
88177	ts	90	"D"	Yes	Yes	No

1990 vehicles
affected:

360 373 48

1991 348 ts / tb

<u>Serial Number</u>	<u>Model</u>	<u>Year</u>	<u>Letter</u>	<u>Recall #147</u>	<u>Recall #148</u>	<u>Recall #149</u>
87896	ts	91	"D"	Yes	Yes	No
87897	ts	91	"D"	Yes	Yes	No
87898	ts	91	"D"	Yes	Yes	No
87917	ts	91	"H"	Yes	No	No
87918	ts	91	"H"	Yes	No	No
87934	ts	91	"H"	Yes	No	No
87935	ts	91	"H"	Yes	No	No
87953	ts	91	"H"	Yes	No	No
87964	ts	91	"H"	Yes	No	No
87966	ts	91	"H"	Yes	No	No
87975	ts	91	"H"	Yes	No	No
87976	ts	91	"H"	Yes	No	No
87977	ts	91	"H"	Yes	No	No
87985	ts	91	"H"	Yes	No	No
87996	ts	91	"H"	Yes	No	No
88014	ts	91	"H"	Yes	No	No
88015	ts	91	"H"	Yes	No	No
88032	ts	91	"H"	Yes	No	No
88033	ts	91	"H"	Yes	No	No
88053	ts	91	"H"	Yes	No	No
88054	ts	91	"H"	Yes	No	No
88072	ts	91	"H"	Yes	No	No
88073	ts	91	"H"	Yes	No	No
88091	ts	91	"H"	Yes	No	No
88092	ts	91	"H"	Yes	No	No
88223	ts	91	"H"	Yes	No	No
88232	ts	91	"H"	Yes	No	No
88272	ts	91	"H"	Yes	No	No
88288	ts	91	"H"	Yes	No	No
88335	ts	91	"H"	Yes	No	No
88386	ts	91	"H"	Yes	No	No
88434	ts	91	"H"	Yes	No	No
88479	ts	91	"H"	Yes	No	No
88527	ts	91	"H"	Yes	No	No
88528	ts	91	"H"	Yes	No	No
88532	ts	91	"H"	Yes	No	No
88545	ts	91	"H"	Yes	No	No
88544	ts	91	"H"	Yes	No	No
88558	ts	91	"H"	Yes	No	No
88559	ts	91	"H"	Yes	No	No
88560	ts	91	"H"	Yes	No	No
88576	ts	91	"H"	Yes	No	No
88577	ts	91	"H"	Yes	No	No
88591	ts	91	"H"	Yes	No	No
88594	ts	91	"H"	Yes	No	No
88595	ts	91	"H"	Yes	No	No
88613	ts	91	"H"	Yes	No	No
88614	ts	91	"H"	Yes	No	No
88629	ts	91	"H"	Yes	No	No
88646	ts	91	"H"	Yes	No	No
88661	ts	91	"H"	Yes	No	No

<u>Serial Number</u>	<u>Model</u>	<u>Year</u>	<u>Letter</u>	<u>Recall #147</u>	<u>Recall #148</u>	<u>Recall #149</u>
88677	tr	91	"H"	Yes	No	No
88678	tr	91	"H"	Yes	No	No
88690	tr	91	"H"	Yes	No	No
88695	tr	91	"H"	Yes	No	No
88696	tr	91	"H"	Yes	No	No
88712	tr	91	"H"	Yes	No	No
88713	tr	91	"H"	Yes	No	No
88731	tr	91	"H"	Yes	No	No
88732	tr	91	"H"	Yes	No	No
88733	tr	91	"H"	Yes	No	No
88749	tr	91	"H"	Yes	No	No
88804	tr	91	"H"	Yes	No	No
88874	tr	91	"H"	Yes	No	No
88923	tr	91	"H"	Yes	No	No
88924	tr	91	"H"	Yes	No	No
88941	tr	91	"H"	Yes	No	No
88959	tr	91	"H"	Yes	No	No
88985	tr	91	"H"	Yes	No	No
88986	tr	91	"H"	Yes	No	No
88987	tr	91	"H"	Yes	No	No
89012	tr	91	"H"	Yes	No	No
89031	tr	91	"H"	Yes	No	No
89040	tr	91	"H"	Yes	No	No
89051	tr	91	"H"	Yes	No	No
89060	tr	91	"H"	Yes	No	No
89070	tr	91	"H"	Yes	No	No
89071	tr	91	"H"	Yes	No	No
89084	tr	91	"H"	Yes	No	No
89090	tr	91	"H"	Yes	No	No
89095	tr	91	"H"	Yes	No	No
89107	tr	91	"H"	Yes	No	No
89108	tr	91	"H"	Yes	No	No
89126	tr	91	"H"	Yes	No	No
89127	tr	91	"H"	Yes	No	No
89145	tr	91	"H"	Yes	No	No
89148	tr	91	"H"	Yes	No	No
89164	tr	91	"H"	Yes	No	No
89165	tr	91	"H"	Yes	No	No
89181	tr	91	"H"	Yes	No	No
89183	tr	91	"H"	Yes	No	No
89194	tr	91	"H"	Yes	No	No
89202	tr	91	"H"	Yes	No	No
89203	tr	91	"H"	Yes	No	No
89221	tr	91	"H"	Yes	No	No
89222	tr	91	"H"	Yes	No	No
89240	tr	91	"H"	Yes	No	No
89241	tr	91	"H"	Yes	No	No
89259	tr	91	"H"	Yes	No	No
89260	tr	91	"H"	Yes	No	No
89278	tr	91	"H"	Yes	No	No
89279	tr	91	"H"	Yes	No	No

<u>Serial Number</u>	<u>Model</u>	<u>Year</u>	<u>Letter</u>	<u>Recall #147</u>	<u>Recall #148</u>	<u>Recall #149</u>
89297	ts	91	"H"	Yes	No	No
89298	ts	91	"H"	Yes	No	No
89316	ts	91	"H"	Yes	No	No
89317	ts	91	"H"	Yes	No	No
89337	ts	91	"H"	Yes	No	No
89338	ts	91	"H"	Yes	No	No
89345	tb	91	"H"	Yes	No	No
89353	ts	91	"H"	Yes	No	No
89354	ts	91	"H"	Yes	No	No
89380	tb	91	"H"	Yes	No	No
89372	ts	91	"H"	Yes	No	No
89373	ts	91	"H"	Yes	No	No
89392	ts	91	"H"	Yes	No	No
89393	ts	91	"H"	Yes	No	No
89411	ts	91	"H"	Yes	No	No
89448	tb	91	"H"	Yes	No	No
89450	ts	91	"H"	Yes	No	No
89451	ts	91	"H"	Yes	No	No
89470	ts	91	"H"	Yes	No	No
89488	ts	91	"H"	Yes	No	No
89489	ts	91	"H"	Yes	No	No
89508	ts	91	"H"	Yes	No	No
89527	ts	91	"H"	Yes	No	No
89548	ts	91	"H"	Yes	No	No
89563	ts	91	"H"	Yes	No	No
89568	ts	91	"H"	Yes	No	No
89569	ts	91	"H"	Yes	No	No
89588	ts	91	"H"	Yes	No	No
89589	ts	91	"H"	Yes	No	No
89606	ts	91	"H"	Yes	No	No
89607	ts	91	"H"	Yes	No	No
89625	ts	91	"H"	Yes	No	No
89626	ts	91	"H"	Yes	No	No
89639	tb	91	"H"	Yes	No	No
89645	ts	91	"H"	Yes	No	No
89648	ts	91	"H"	Yes	No	No
89663	ts	91	"H"	Yes	No	No
89664	ts	91	"H"	Yes	No	No
89682	ts	91	"H"	Yes	No	No
89693	ts	91	"H"	Yes	No	No
89700	ts	91	"H"	Yes	No	No
89701	ts	91	"H"	Yes	No	No
89720	ts	91	"H"	Yes	No	No
89721	ts	91	"H"	Yes	No	No
89735	ts	91	"H"	Yes	No	No
89736	ts	91	"H"	Yes	No	No
89752	tb	91	"H"	Yes	No	No
89753	ts	91	"H"	Yes	No	No
89754	ts	91	"H"	Yes	No	No
89772	ts	91	"H"	Yes	No	No
89773	ts	91	"H"	Yes	No	No

<u>Serial Number</u>	<u>Model</u>	<u>Year</u>	<u>Letter</u>	<u>Recall #147</u>	<u>Recall #148</u>	<u>Recall #149</u>
89791	89	91	"H"	Yes	No	No
89792	89	91	"H"	Yes	No	No
89805	89	91	"H"	Yes	No	No
89810	89	91	"H"	Yes	No	No
89811	89	91	"H"	Yes	No	No
89829	89	91	"H"	Yes	No	No
89830	89	91	"H"	Yes	No	No
89847	89	91	"H"	Yes	No	No
89848	89	91	"H"	Yes	No	No
89863	89	91	"H"	Yes	No	No
89887	89	91	"H"	Yes	No	No
89888	89	91	"H"	Yes	No	No
89886	89	91	"H"	Yes	No	No
89887	89	91	"H"	Yes	No	No
89900	89	91	"H"	Yes	No	No
89904	89	91	"H"	Yes	No	No
89905	89	91	"H"	Yes	No	No
89921	89	91	"H"	Yes	No	No
89924	89	91	"H"	Yes	No	No
89925	89	91	"H"	Yes	No	No
89928	89	91	"H"	Yes	No	No
89943	89	91	"H"	Yes	No	No
89964	89	91	"H"	Yes	No	No
89978	89	91	"H"	Yes	No	No
89980	89	91	"H"	Yes	No	No
89981	89	91	"H"	Yes	No	No
89999	89	91	"H"	Yes	No	No
90002	89	91	"H"	Yes	No	No
90019	89	91	"H"	Yes	No	No
90035	89	91	"H"	Yes	No	No
90037	89	91	"H"	Yes	No	No
90058	89	91	"H"	Yes	No	No
90073	89	91	"H"	Yes	No	No
90080	89	91	"H"	Yes	No	No
90094	89	91	"H"	Yes	No	No
90114	89	91	"H"	Yes	No	No
90135	89	91	"H"	Yes	No	No
90153	89	91	"H"	Yes	No	No
90154	89	91	"H"	Yes	No	No
90163	89	91	"H"	Yes	No	No
90173	89	91	"H"	Yes	No	No
90193	89	91	"H"	Yes	No	No
90210	89	91	"H"	Yes	No	No
90212	89	91	"H"	Yes	No	No
90231	89	91	"H"	Yes	No	No
90250	89	91	"H"	Yes	No	No
90268	89	91	"H"	Yes	No	No
90285	89	91	"H"	Yes	No	No
90286	89	91	"H"	Yes	No	No
90287	89	91	"H"	Yes	No	No
90297	89	91	"H"	Yes	No	No

<u>Serial Number</u>	<u>Model</u>	<u>Year</u>	<u>Letter</u>	<u>Recall #147</u>	<u>Recall #148</u>	<u>Recall #149</u>
90298	tz	91	"H"	Yes	No	No
90304	tz	91	"H"	Yes	No	No
90305	tz	91	"H"	Yes	No	No
90323	ts	91	"H"	Yes	No	No
90324	ts	91	"H"	Yes	No	No
90325	ts	91	"H"	Yes	No	No
90340	ts	91	"H"	Yes	No	No
90341	ts	91	"H"	Yes	No	No
90342	ts	91	"H"	Yes	No	No
90358	ts	91	"H"	Yes	No	No
90359	ts	91	"H"	Yes	No	No
90376	ts	91	"H"	Yes	No	No
90377	ts	91	"H"	Yes	No	No
90378	ts	91	"H"	Yes	No	No
90379	ts	91	"H"	Yes	No	No
90396	ts	91	"H"	Yes	No	No
90397	ts	91	"H"	Yes	No	No
90398	ts	91	"H"	Yes	No	No
90414	ts	91	"H"	Yes	No	No
90415	ts	91	"H"	Yes	No	No
90416	ts	91	"H"	Yes	No	No
90417	ts	91	"H"	Yes	No	No
90434	ts	91	"H"	Yes	No	No
90435	ts	91	"H"	Yes	No	No
90452	ts	91	"H"	Yes	No	No
90453	ts	91	"H"	Yes	No	No
90454	ts	91	"H"	Yes	No	No
90455	ts	91	"H"	Yes	No	No
90472	ts	91	"H"	Yes	No	No
90473	ts	91	"H"	Yes	No	No
90474	ts	91	"H"	Yes	No	No
90498	ts	91	"H"	Yes	No	No
90499	ts	91	"H"	Yes	No	No
90490	ts	91	"H"	Yes	No	No
90496	ts	91	"H"	Yes	No	No
90510	ts	91	"H"	Yes	No	No
90511	ts	91	"H"	Yes	No	No
90516	ts	91	"H"	Yes	No	No
90517	ts	91	"H"	Yes	No	No
90531	ts	91	"H"	Yes	No	No
90536	ts	91	"H"	Yes	No	No
90537	ts	91	"H"	Yes	No	No
90538	ts	91	"H"	Yes	No	No
90555	ts	91	"H"	Yes	No	No
90556	ts	91	"H"	Yes	No	No
90557	ts	91	"H"	Yes	No	No
90573	ts	91	"H"	Yes	No	No
90576	ts	91	"H"	Yes	No	No
90577	ts	91	"H"	Yes	No	No
90578	ts	91	"H"	Yes	No	No
90593	ts	91	"H"	Yes	No	No

<u>Serial Number</u>	<u>Model</u>	<u>Year</u>	<u>Letter</u>	<u>Recall #147</u>	<u>Recall #148</u>	<u>Recall #149</u>
90594	ts	91	"H"	Yes	No	No
90595	ts	91	"H"	Yes	No	No
90613	tb	91	"H"	Yes	No	No
90614	ts	91	"H"	Yes	No	No
90615	ts	91	"H"	Yes	No	No
90616	ts	91	"H"	Yes	No	No
90632	ts	91	"H"	Yes	No	No
90633	ts	91	"H"	Yes	No	No
90634	ts	91	"H"	Yes	No	No
90649	tb	91	"H"	Yes	No	No
90653	ts	91	"H"	Yes	No	No
90654	ts	91	"H"	Yes	No	No
90655	ts	91	"H"	Yes	No	No
90679	tb	91	"H"	Yes	No	No
90773	tb	91	"H"	Yes	No	No
90811	ts	91	"H"	Yes	No	No
90848	ts	91	"H"	Yes	No	No
90882	tb	91	"H"	Yes	No	No
90941	tb	91	"H"	Yes	No	No
90967	tb	91	"H"	Yes	No	No

1991 vehicles

affected: 275 3 0

1992 348 ts / tb

<u>Serial Number</u>	<u>Model</u>	<u>Year</u>	<u>Letter</u>	<u>Recall #147</u>	<u>Recall #148</u>	<u>Recall #149</u>
90672	ts	92	"H"	Yes	No	No
90673	ts	92	"H"	Yes	No	No
90674	ts	92	"H"	Yes	No	No
90690	ts	92	"H"	Yes	No	No
90691	ts	92	"H"	Yes	No	No
90692	ts	92	"H"	Yes	No	No
90710	ts	92	"H"	Yes	No	No
90711	ts	92	"H"	Yes	No	No
90712	ts	92	"H"	Yes	No	No
90728	ts	92	"H"	Yes	No	No
90729	ts	92	"H"	Yes	No	No
90730	ts	92	"H"	Yes	No	No
90747	ts	92	"H"	Yes	No	No
90748	ts	92	"H"	Yes	No	No
90749	ts	92	"H"	Yes	No	No
90766	ts	92	"H"	Yes	No	No
90767	ts	92	"H"	Yes	No	No
90768	ts	92	"H"	Yes	No	No
90785	ts	92	"H"	Yes	No	No
90786	ts	92	"H"	Yes	No	No
90810	ts	92	"H"	Yes	No	No

<u>Serial Number</u>	<u>Model</u>	<u>Year</u>	<u>Letter</u>	<u>Recall #147</u>	<u>Recall #148</u>	<u>Recall #149</u>
90828	ts	92	"H"	Yes	No	No
90829	ts	92	"H"	Yes	No	No
90846	ts	92	"H"	Yes	No	No
90847	ts	92	"H"	Yes	No	No
90862	ts	92	"H"	Yes	No	No
90878	ts	92	"H"	Yes	No	No
90881	ts	92	"H"	Yes	No	No
90901	ts	92	"H"	Yes	No	No
90902	ts	92	"H"	Yes	No	No
90919	ts	92	"H"	Yes	No	No
90930	ts	92	"H"	Yes	No	No
90985	ts	92	"H"	Yes	No	No
90989	ts	92	"H"	Yes	No	No
91007	ts	92	"H"	Yes	No	No
91009	ts	92	"H"	Yes	No	No
91029	ts	92	"H"	Yes	No	No
91049	ts	92	"H"	Yes	No	No
91057	ts	92	"H"	Yes	No	No
91065	ts	92	"H"	Yes	No	No
91076	ts	92	"H"	Yes	No	No
91082	ts	92	"H"	Yes	No	No
91094	ts	92	"H"	Yes	No	No
91113	ts	92	"H"	Yes	No	No
91128	ts	92	"H"	Yes	No	No
9113C	ts	92	"H"	Yes	No	No
91139	ts	92	"H"	Yes	No	No
91141	ts	92	"H"	Yes	No	No
91154	ts	92	"H"	Yes	No	No
91177	ts	92	"H"	Yes	No	No
91195	ts	92	"H"	Yes	No	No
91197	ts	92	"H"	Yes	No	No
91208	ts	92	"H"	Yes	No	No
91213	ts	92	"H"	Yes	No	No
91231	ts	92	"H"	Yes	No	No
91248	ts	92	"H"	Yes	No	No
91263	ts	92	"H"	Yes	No	No
91278	ts	92	"H"	Yes	No	No
91298	ts	92	"H"	Yes	No	No
91315	ts	92	"H"	Yes	No	No
91350	ts	92	"H"	Yes	No	No
91370	ts	92	"H"	Yes	No	No
91406	ts	92	"H"	Yes	No	No
91526	ts	92	"H"	Yes	No	No
91547	ts	92	"H"	Yes	No	No
91578	ts	92	"H"	Yes	No	No
91598	ts	92	"H"	Yes	No	No
91621	ts	92	"H"	Yes	No	No
91653	ts	92	"H"	Yes	No	No
91670	ts	92	"H"	Yes	No	No
91673	ts	92	"H"	Yes	No	No
91897	ts	92	"H"	Yes	No	No

<u>Serial Number</u>	<u>Model</u>	<u>Year</u>	<u>Letter</u>	<u>Recall #147</u>	<u>Recall #148</u>	<u>Recall #149</u>
91729	B	92	"H"	Yes	No	No
91746	B	92	"H"	Yes	No	No
91754	B	92	"H"	Yes	No	No
91776	B	92	"H"	Yes	No	No
91796	B	92	"H"	Yes	No	No
91810	B	92	"H"	Yes	No	No
91839	B	92	"H"	Yes	No	No
91858	B	92	"H"	Yes	No	No
91879	B	92	"H"	Yes	No	No
91896	B	92	"H"	Yes	No	No
91926	B	92	"H"	Yes	No	No
91956	B	92	"H"	Yes	No	No
91980	B	92	"H"	Yes	No	No
91991	B	92	"H"	Yes	No	No
92007	B	92	"H"	Yes	No	No
92026	B	92	"H"	Yes	No	No
92042	B	92	"H"	Yes	No	No
92045	B	92	"H"	Yes	No	No
92046	B	92	"H"	Yes	No	No
92083	B	92	"H"	Yes	No	No
92092	B	92	"H"	Yes	No	No
92100	B	92	"H"	Yes	No	No
92108	B	92	"H"	Yes	No	No
92121	B	92	"H"	Yes	No	No
92137	B	92	"H"	Yes	No	No
92155	B	92	"H"	Yes	No	No
92173	B	92	"H"	Yes	No	No
92174	B	92	"H"	Yes	No	No
92191	B	92	"H"	Yes	No	No
92208	B	92	"H"	Yes	No	No

1992 vehicles
affected:

102 0 0

1990 Testarossa

<u>Serial Number</u>	<u>Model</u>	<u>Year</u>	<u>Letter</u>	<u>Recall #148</u>	<u>Serial Number</u>	<u>Model</u>	<u>Year</u>	<u>Letter</u>	<u>Recall #148</u>
85658	512	90	'E'	Yes	86206	512	90	'E'	Yes
85659	512	90	'E'	No	86207	512	90	'E'	Yes
85661	512	90	'E'	No	86222	512	90	'E'	Yes
85678	512	90	'E'	Yes	86224	512	90	'E'	Yes
85679	512	90	'E'	Yes	86227	512	90	'E'	Yes
85680	512	90	'F'	Yes	86242	512	90	'E'	Yes
85698	512	90	'E'	Yes	86244	512	90	'E'	Yes
85699	512	90	'E'	Yes	86261	512	90	'E'	Yes
85717	512	90	'E'	Yes	86265	512	90	'E'	Yes
85721	512	90	'E'	Yes	86300	512	90	'E'	Yes
85737	512	90	'E'	Yes	86318	512	90	'F'	Yes
85774	512	90	'E'	Yes	86322	512	90	'E'	Yes
85777	512	90	'E'	Yes	86335	512	90	'E'	Yes
85785	512	90	'E'	Yes	86354	512	90	'E'	Yes
85795	512	90	'F'	Yes	86508	512	90	'E'	Yes
85799	512	90	'E'	Yes	86509	512	90	'E'	Yes
85816	512	90	'E'	Yes	86786	512	90	'E'	Yes
85819	512	90	'E'	Yes	86787	512	90	'E'	Yes
85836	512	90	'E'	Yes	86983	512	90	'E'	Yes
85837	512	90	'E'	Yes	86864	512	90	'E'	Yes
85862	512	90	'E'	No	86865	512	90	'E'	Yes
85863	512	90	'E'	No	86957	512	90	'E'	Yes
85881	512	90	'E'	No	86960	512	90	'E'	Yes
85884	512	90	'E'	No	86975	512	90	'E'	Yes
85901	512	90	'E'	No	86977	512	90	'E'	Yes
85923	512	90	'E'	No	86985	512	90	'E'	Yes
85938	512	90	'E'	No	86997	512	90	'E'	Yes
85941	512	90	'E'	No	87012	512	90	'E'	Yes
85942	512	90	'E'	No	87013	512	90	'E'	Yes
85956	512	90	'E'	No	87014	512	90	'E'	Yes
85976	512	90	'E'	No	87096	512	90	'E'	Yes
85978	512	90	'E'	No	87097	512	90	'E'	Yes
85997	512	90	'E'	No	87098	512	90	'E'	Yes
85998	512	90	'E'	No	87099	512	90	'E'	Yes
86018	512	90	'E'	No	87100	512	90	'E'	Yes
86031	512	90	'E'	No	87113	512	90	'E'	Yes
86032	512	90	'E'	No	87114	512	90	'E'	Yes
86051	512	90	'E'	No	87115	512	90	'E'	Yes
86063	512	90	'E'	No	87116	512	90	'E'	Yes
86070	512	90	'E'	No	87117	512	90	'E'	Yes
86069	512	90	'E'	Yes	87118	512	90	'E'	Yes
86090	512	90	'E'	No	87132	512	90	'E'	Yes
86092	512	90	'E'	No	87134	512	90	'E'	Yes
86093	512	90	'E'	No	87135	512	90	'E'	Yes
86111	512	90	'E'	No	87136	512	90	'E'	Yes
86155	512	90	'E'	No	87137	512	90	'E'	Yes
86166	512	90	'E'	No	87138	512	90	'E'	Yes
86170	512	90	'E'	No	87140	512	90	'E'	Yes
86180	512	90	'E'	No	87231	512	90	'E'	Yes
86183	512	90	'E'	No	87232	512	90	'E'	Yes
86184	512	90	'E'	No					
86186	512	90	'E'	No					
86202	512	90	'E'	Yes					
86204	512	90	'E'	Yes					
86206	512	90	'E'	Yes					

1991 Testarossa

<u>Serial Number</u>	<u>Model</u>	<u>Year</u>	<u>Letter</u>	<u>Recall #148</u>	<u>Serial Number</u>	<u>Model</u>	<u>Year</u>	<u>Letter</u>	<u>Recall #148</u>
87233	512	90	"E"	Yes	86355	512	91	"E"	Yes
87234	512	90	"E"	Yes	86356	512	91	"E"	Yes
87235	512	90	"E"	Yes	86372	512	91	"E"	Yes
87236	512	90	"E"	Yes	86374	512	91	"E"	Yes
87250	512	90	"E"	Yes	86376	512	91	"E"	Yes
87251	512	90	"E"	Yes	86387	512	91	"E"	Yes
87252	512	90	"E"	Yes	86411	512	91	"E"	Yes
87253	512	90	"E"	Yes	86414	512	91	"E"	Yes
87254	512	90	"E"	Yes	86416	512	91	"E"	Yes
87255	512	90	"E"	Yes	86432	512	91	"E"	Yes
87269	512	90	"E"	Yes	86436	512	91	"E"	Yes
87270	512	90	"E"	Yes	86437	512	91	"E"	Yes
87271	512	90	"E"	Yes	86452	512	91	"E"	Yes
87272	512	90	"E"	Yes	86453	512	91	"E"	Yes
87273	512	90	"E"	Yes	86454	512	91	"E"	Yes
87274	512	90	"E"	Yes	86455	512	91	"E"	Yes
87289	512	90	"E"	Yes	86456	512	91	"E"	Yes
87290	512	90	"E"	Yes	86457	512	91	"E"	Yes
87291	512	90	"E"	Yes	86458	512	91	"E"	Yes
87292	512	90	"E"	Yes	86471	512	91	"E"	Yes
87293	512	90	"E"	Yes	86472	512	91	"E"	Yes
87368	512	90	"E"	Yes	86473	512	91	"E"	Yes
					86474	512	91	"E"	Yes
					86490	512	91	"E"	Yes
					86491	512	91	"E"	Yes
					86492	512	91	"E"	Yes
					86493	512	91	"E"	Yes
					86494	512	91	"E"	Yes
					86495	512	91	"E"	Yes
					86737	512	91	"E"	Yes
					86738	512	91	"E"	Yes
					86739	512	91	"E"	Yes
					86740	512	91	"E"	Yes
					86741	512	91	"E"	Yes
					86742	512	91	"E"	Yes
					86747	512	91	"E"	Yes
					86748	512	91	"E"	Yes
					86749	512	91	"E"	Yes
					86750	512	91	"E"	Yes
					86751	512	91	"E"	Yes
					86752	512	91	"E"	Yes
					86753	512	91	"E"	Yes
					86756	512	91	"E"	Yes
					86757	512	91	"E"	Yes
					86758	512	91	"E"	Yes
					86759	512	91	"E"	Yes
					86760	512	91	"E"	Yes
					86764	512	91	"E"	Yes
1990 Vehicles									
Affected:	94								

Serial Number Model Year Letter Recall #148

Serial Number Model Year Letter Recall #148

80785

512

07

HEB

MS

07400

510

07

HEB

MS

1989 Mondial 1

<u>Serial Number</u>	<u>Model</u>	<u>Year</u>	<u>Letter</u>	<u>Recap #147</u>	<u>Recap #148</u>
81342	cpe	89	F	Yes	No
81374	cab	89	F	Yes	No
81380	cab	89	F	Yes	No
81390	cab	89	F	Yes	No
81396	cab	89	F	Yes	No
81481	cab	89	F	Yes	No
81487	cab	89	F	Yes	No
81498	cpe	89	F	Yes	No
81504	cpe	89	F	Yes	No
81514	cpe	89	F	Yes	No
81515	cab	89	F	Yes	No
81520	cpe	89	F	Yes	No
81534	cab	89	F	Yes	No
81545	cab	89	F	Yes	No
81551	cab	89	F	Yes	No
81563	cab	89	F	Yes	No
81575	cpe	89	F	Yes	No
81588	cab	89	F	Yes	No
81598	cab	89	F	Yes	No
81605	cpe	89	F	Yes	No
81611	cab	89	F	Yes	No
81629	cab	89	F	Yes	No
81641	cab	89	F	Yes	No
81757	cab	89	F	Yes	No
81774	cab	89	F	Yes	No
81791	cpe	89	F	Yes	No
81801	cpe	89	F	Yes	No
81802	cpe	89	F	Yes	No
81809	cab	89	F	Yes	No
81815	cpe	89	F	Yes	No
81820	cpe	89	F	Yes	No
81821	cpe	89	F	Yes	No
81822	cpe	89	F	Yes	No
81834	cpe	89	F	Yes	No
81835	cpe	89	F	Yes	No
81844	cab	89	F	Yes	No
81850	cab	89	F	Yes	No
81861	cpe	89	F	Yes	No
81862	cpe	89	F	Yes	No
81876	cab	89	F	Yes	No
81880	cab	89	F	Yes	No
81881	cab	89	F	Yes	No
81883	cab	89	F	Yes	No
81885	cab	89	F	Yes	No
81896	cab	89	F	Yes	No
81899	cab	89	F	Yes	No
81900	cab	89	F	Yes	No
81901	cab	89	F	Yes	No
81902	cab	89	F	Yes	No
81909	cab	89	F	Yes	No
81914	cab	89	F	Yes	No
81916	cpe	89	F	Yes	No
81917	cab	89	F	Yes	No
81920	cab	89	F	Yes	No
81923	cab	89	F	Yes	No
81936	cab	89	F	Yes	No

<u>Serial Number</u>	<u>Model</u>	<u>Year</u>	<u>Letter</u>	<u>Recall #147</u>	<u>Recall #148</u>
81939	cab	89	"F"	Yes	No
81943	cab	89	"F"	Yes	No
81947	cab	89	"F"	Yes	No
81955	cab	89	"F"	Yes	No
81968	cab	89	"F"	Yes	No
81969	cab	89	"F"	Yes	No
81963	cab	89	"F"	Yes	No
81964	cab	89	"F"	Yes	No
81968	cab	89	"F"	Yes	No
81970	cab	89	"F"	Yes	No
81973	cab	89	"F"	Yes	No
81974	cpe	89	"F"	Yes	No
81975	cab	89	"F"	Yes	No
81976	cab	89	"F"	Yes	No
81980	cpe	89	"F"	Yes	No
81984	cab	89	"F"	Yes	No
81987	cab	89	"F"	Yes	No
81990	cab	89	"F"	Yes	No
81991	cab	89	"F"	Yes	No
81993	cab	89	"F"	Yes	No
81998	cab	89	"F"	Yes	No
82012	cab	89	"F"	Yes	No
82016	cpe	89	"F"	Yes	No
82019	cab	89	"F"	Yes	No
82022	cab	89	"F"	Yes	No
82032	cab	89	"F"	Yes	No
82036	cab	89	"F"	Yes	No
82040	cab	89	"F"	Yes	No
82043	cab	89	"F"	Yes	No
82052	cab	89	"F"	Yes	No
82056	cab	89	"F"	Yes	No
82059	cpe	89	"F"	Yes	No
82061	cab	89	"F"	Yes	No
82070	cab	89	"F"	Yes	No
82073	cab	89	"F"	Yes	No
82077	cab	89	"F"	Yes	No
82083	cab	89	"F"	Yes	No
82090	cab	89	"F"	Yes	No
82093	cab	89	"F"	Yes	No
82097	cpe	89	"F"	Yes	No
82100	cab	89	"F"	Yes	No
82111	cab	89	"F"	Yes	No
82114	cab	89	"F"	Yes	No
82118	cab	89	"F"	Yes	No
82121	cab	89	"F"	Yes	No
82131	cab	89	"F"	Yes	No
82134	cab	89	"F"	Yes	No
82136	cpe	89	"F"	Yes	No
82139	cab	89	"F"	Yes	No
82142	cab	89	"F"	Yes	No
82154	cab	89	"F"	Yes	No
82156	cpe	89	"F"	Yes	No

<u>Serial Number</u>	<u>Model</u>	<u>Year</u>	<u>Letter</u>	<u>Recall #147</u>	<u>Recall #148</u>
82159	cab	89	"F"	Yes	No
82162	cab	89	"F"	Yes	No
82165	cab	89	"F"	Yes	No
82172	cab	89	"F"	Yes	No
82176	cab	89	"F"	Yes	No
82182	cab	89	"F"	Yes	No
82195	cab	89	"F"	Yes	No
82198	cab	89	"F"	Yes	No
82200	ope	89	"F"	Yes	No
82203	cab	89	"F"	Yes	No
82215	cab	89	"F"	Yes	No
82218	cab	89	"F"	Yes	No
82222	cab	89	"F"	Yes	No
82226	cab	89	"F"	Yes	No
82235	cab	89	"F"	Yes	No
82238	cab	89	"F"	Yes	No
82242	ope	89	"F"	Yes	No
82246	cab	89	"F"	Yes	No
82255	cab	89	"F"	Yes	No
82257	cab	89	"F"	Yes	No
82262	cab	89	"F"	Yes	No
82266	cab	89	"F"	Yes	No
82275	cab	89	"F"	Yes	No
82279	cab	89	"F"	Yes	No
82283	cab	89	"F"	Yes	No
82287	ope	89	"F"	Yes	No
82295	cab	89	"F"	Yes	No
82299	cab	89	"F"	Yes	No
82303	cab	89	"F"	Yes	No
82307	cab	89	"F"	Yes	No
82315	cab	89	"F"	Yes	No
82319	ope	89	"F"	Yes	No
82323	cab	89	"F"	Yes	No
82327	cab	89	"F"	Yes	No
82334	cab	89	"F"	Yes	No
82338	cab	89	"F"	Yes	No
82341	cab	89	"F"	Yes	No
82344	cab	89	"F"	Yes	No
82348	cab	89	"F"	Yes	No
82351	ope	89	"F"	Yes	No
82354	cab	89	"F"	Yes	No
82357	cab	89	"F"	Yes	No
82364	cab	89	"F"	Yes	No
82367	cab	89	"F"	Yes	No
82370	cab	89	"F"	Yes	No
82373	cab	89	"F"	Yes	No
82378	cab	89	"F"	Yes	No
82381	ope	89	"F"	Yes	No
82384	cab	89	"F"	Yes	No
82388	cab	89	"F"	Yes	No
82394	cab	89	"F"	Yes	No
82397	cab	89	"F"	Yes	No

<u>Serial Number</u>	<u>Model</u>	<u>Year</u>	<u>Letter</u>	<u>Recall #147</u>	<u>Recall #149</u>
82401	cab	89	"F"	Yes	No
82405	cab	89	"F"	Yes	No
82408	cab	89	"F"	Yes	No
82412	cab	89	"F"	Yes	No
82416	cpe	89	"F"	Yes	No
82420	cab	89	"F"	Yes	No
82424	cab	89	"F"	Yes	No
82428	cab	89	"F"	Yes	No
82431	cab	89	"F"	Yes	No
82434	cab	89	"F"	Yes	No
82438	cab	89	"F"	Yes	No
82442	cab	89	"F"	Yes	No
82445	cpe	89	"F"	Yes	No
82447	cab	89	"F"	Yes	No
82451	cab	89	"F"	Yes	No
82455	cab	89	"F"	Yes	No
82458	cab	89	"F"	Yes	No
82462	cab	89	"F"	Yes	No
82466	cab	89	"F"	Yes	No
82472	cab	89	"F"	Yes	No
82475	cpe	89	"F"	Yes	No
82479	cab	89	"F"	Yes	No
82483	cab	89	"F"	Yes	No
82490	cab	89	"F"	Yes	No
82494	cab	89	"F"	Yes	No
82498	cab	89	"F"	Yes	No
82502	cab	89	"F"	Yes	No
82508	cab	89	"F"	Yes	No
82511	cab	89	"F"	Yes	No
82515	cpe	89	"F"	Yes	No
82519	cab	89	"F"	Yes	No
82523	cab	89	"F"	Yes	No
82527	cab	89	"F"	Yes	No
82530	cab	89	"F"	Yes	No
82533	cab	89	"F"	Yes	No
82539	cab	89	"F"	Yes	No
82543	cab	89	"F"	Yes	No
82547	cpe	89	"F"	Yes	No
82550	cab	89	"F"	Yes	No
82553	cpe	89	"F"	Yes	No
82559	cab	89	"F"	Yes	No
82563	cab	89	"F"	Yes	No
82567	cab	89	"F"	Yes	No
82571	cab	89	"F"	Yes	No
82574	cpe	89	"F"	Yes	No
82590	cpe	89	"F"	Yes	No
82583	cpe	89	"F"	Yes	No
82587	cpe	89	"F"	Yes	No

1989 Vehicles

Affected:	Cabriolet	156	TOTAL
	Coupe	42	208

1990 Mondial I

<u>Serial Number</u>	<u>Model</u>	<u>Year</u>	<u>Letter</u>	<u>Recall #147</u>	<u>Recall #148</u>
84665	cab	90	"F"	Yes	No
85307	cab	90	"F"	Yes	No
85380	cab	90	"F"	Yes	No
85439	cab	90	"F"	Yes	No
85507	cab	90	"F"	Yes	No
85558	cab	90	"F"	Yes	No
85573	cab	90	"F"	Yes	No
85615	cab	90	"F"	Yes	No
85674	cab	90	"F"	Yes	No
85714	cab	90	"F"	Yes	No
85771	cab	90	"F"	Yes	No
85831	cab	90	"F"	Yes	No
85868	cab	90	"F"	Yes	No
85927	cab	90	"G"	Yes	Yes
85966	cab	90	"G"	Yes	Yes
86079	cab	90	"G"	Yes	Yes
86115	cab	90	"G"	Yes	Yes
86152	cab	90	"G"	Yes	Yes
86190	cab	90	"G"	Yes	Yes
86247	cab	90	"G"	Yes	Yes
86306	cab	90	"G"	Yes	Yes
86364	cab	90	"G"	Yes	Yes
86423	cab	90	"G"	Yes	Yes
86441	cab	90	"G"	Yes	Yes
86463	cab	90	"G"	Yes	Yes
86480	cab	90	"G"	Yes	Yes
86500	cab	90	"G"	Yes	Yes
86520	cab	90	"G"	Yes	Yes
86551	cab	90	"G"	Yes	Yes
86570	cab	90	"G"	Yes	Yes
86589	cab	90	"G"	Yes	Yes
86528	cab	90	"G"	Yes	Yes
86647	cab	90	"G"	Yes	Yes
86666	cab	90	"G"	Yes	Yes
86687	cab	90	"G"	Yes	Yes
86688	cab	90	"G"	Yes	Yes
86704	cab	90	"G"	Yes	Yes
86715	cab	90	"G"	Yes	Yes
86734	cab	90	"G"	Yes	Yes
86753	cab	90	"G"	Yes	Yes
86771	cab	90	"G"	Yes	Yes
86791	cab	90	"G"	Yes	Yes
86810	cab	90	"G"	Yes	Yes
86829	cab	90	"G"	Yes	Yes
86848	cab	90	"G"	Yes	Yes
86866	cab	90	"G"	Yes	Yes
86894	cab	90	"G"	Yes	Yes
86914	cab	90	"G"	Yes	Yes
86934	cab	90	"G"	Yes	Yes
86950	cab	90	"G"	Yes	Yes

Serial Number Model Year Letter Recall #147 Recall #148

86951	cab	90	"G"	Yes	Yes
86971	cab	90	"G"	Yes	Yes
86990	cab	90	"G"	Yes	Yes
87009	cab	90	"G"	Yes	Yes
87010	cab	90	"G"	Yes	Yes
87027	cab	90	"G"	Yes	Yes
87028	cab	90	"G"	Yes	Yes
87029	cab	90	"G"	Yes	Yes
87047	cab	90	"G"	Yes	Yes

1991 Mondial t

<u>Serial Number</u>	<u>Model</u>	<u>Year</u>	<u>Letter</u>	<u>Recall #147</u>	<u>Recall #148</u>
88028	cab	91	"F"	Yes	No
88048	cab	91	"F"	Yes	No
88106	cab	91	"F"	Yes	No
88147	cab	91	"F"	Yes	No
88184	cab	91	"F"	Yes	No
88240	cab	91	"F"	Yes	No
88298	cab	91	"F"	Yes	No
88333	cab	91	"F"	Yes	No
88353	cab	91	"F"	Yes	No
88394	cab	91	"F"	Yes	No
88408	cab	91	"F"	Yes	No
88428	cab	91	"F"	Yes	No
88447	cab	91	"F"	Yes	No
88602	cab	91	"F"	Yes	No
88750	cab	91	"F"	Yes	No
88811	cab	91	"F"	Yes	No
88911	cab	91	"F"	Yes	No
88975	cab	91	"F"	Yes	No
89035	cab	91	"F"	Yes	No
89094	cab	91	"F"	Yes	No
89155	cab	91	"F"	Yes	No
89215	cab	91	"F"	Yes	No
89275	cab	91	"F"	Yes	No
89335	cab	91	"F"	Yes	No
89362	cab	91	"F"	Yes	No
89413	cab	91	"F"	Yes	No
89432	cab	91	"F"	Yes	No
89458	cab	91	"F"	Yes	No
89479	cab	91	"F"	Yes	No
89498	cab	91	"F"	Yes	No
89517	cab	91	"F"	Yes	No
89536	cab	91	"F"	Yes	No
89556	cab	91	"F"	Yes	No
89577	cab	91	"F"	Yes	No
89596	cab	91	"F"	Yes	No
89858	cab	91	"F"	Yes	No
89909	cab	91	"F"	Yes	No
89947	cab	91	"F"	Yes	No
89984	cab	91	"F"	Yes	No
90021	cab	91	"F"	Yes	No
90060	cab	91	"F"	Yes	No
90096	cab	91	"F"	Yes	No
90138	cab	91	"F"	Yes	No
90175	cab	91	"F"	Yes	No
90198	cab	91	"F"	Yes	No
90233	cab	91	"F"	Yes	No

<u>Serial Number</u>	<u>Model</u>	<u>Year</u>	<u>Letter</u>	<u>Recall #147</u>	<u>Recall #148</u>
90270	cab	91	"F"	Yes	No
90306	cab	91	"F"	Yes	No
90392	cab	91	"F"	Yes	No
90461	cab	91	"F"	Yes	No

1991 Vehicles

Affected: 50 0

1992 Mondial t

<u>Serial Number</u>	<u>Model</u>	<u>Year</u>	<u>Letter</u>	<u>Recall #147</u>	<u>Recall #148</u>
90607	cab	92	"F"	Yes	No
90724	cab	92	"F"	Yes	No
90731	cab	92	"F"	Yes	No
90763	cab	92	"F"	Yes	No
90801	cab	92	"F"	Yes	No
90818	cab	92	"F"	Yes	No
90863	cab	92	"F"	Yes	No
90904	cab	92	"F"	Yes	No
90956	cab	92	"F"	Yes	No
91030	cab	92	"F"	Yes	No
91059	cab	92	"F"	Yes	No
91096	cab	92	"F"	Yes	No
91134	cab	92	"F"	Yes	No
91173	cab	92	"F"	Yes	No
91210	cab	92	"F"	Yes	No
91246	cab	92	"F"	Yes	No
91258	cab	92	"F"	Yes	No
91292	cab	92	"F"	Yes	No
91322	cab	92	"F"	Yes	No
91346	cab	92	"F"	Yes	No
91374	cab	92	"F"	Yes	No
91395	cab	92	"F"	Yes	No
91433	cab	92	"F"	Yes	No
91454	cab	92	"F"	Yes	No
91480	cab	92	"F"	Yes	No
91500	cab	92	"F"	Yes	No
91519	cab	92	"F"	Yes	No
91538	cab	92	"F"	Yes	No
91557	cab	92	"F"	Yes	No
91576	cab	92	"F"	Yes	No
91900	cab	92	"F"	Yes	No
91953	cab	92	"F"	Yes	No
92020	cab	92	"F"	Yes	No
92115	cab	92	"F"	Yes	No

1992 Vehicles

Affected: 34 0

Ferrari

Ferrari North America, Inc.
250 Sylvan Avenue
Englewood Cliffs, NJ 07632
201-816-2600
TLX: 248021
FAX: 201-816-2926

August 12, 1992

Mr. James P. Talentino
Office of Defects Investigation
National Highway Traffic Safety Administration
Washington, D.C. 20590

SUBJECT: Recall Campaigns No. 92V-071, 92V-072 and
92V-073

Dear Director:

As a follow-up to our previous correspondence regarding the above mentioned Recall Campaigns that were initiated by Ferrari, we would like to provide you with the following updated information:

- An initial supply of the necessary spare parts was distributed throughout our Authorized Dealer network during the week of June 15, 1992.
- Ferrari North America had sufficient spare parts in stock to update seventy percent (70%) of the vehicles involved in the campaigns, with the balance of the parts available within sixty (60) days.
- The Recall Booklet was distributed throughout our Authorized Dealer network during the week of June 15, 1992.
- The Customer Notification Letters, along with the Recall Forms, were distributed between June 29 and July 18. All customers having potentially affected vehicles have been notified except for those where the notices were returned to us as non-deliverable. Those notices returned to Ferrari North America as non-deliverable are currently being researched.



- There was a slight delay of two weeks in sending out the Customer Notification Letters due to a problem with the printing of the recall envelopes.

Should you have any further questions or require additional information, please feel free to contact me.

Yours truly,



Kenneth W. McCay
Director of Service & Parts





Ferrari
NORTH AMERICA, INC.
250 SYLVAN AVENUE
ENGLEWOOD CLIFFS, N.J. 07632

URGENT - RECALL CAMPAIGN NOTIFICATION

Ferruzzi

NORTH AMERICA, INC.

1 LOCATION NUMBER PER FACTORY USE ONLY

RECALL CAMPAIGN FORM

COPY #1 RETURN TO FACTORY		COPY #2 PARTS COPY RETAIN WITH PARTS		COPY #3 RECALL CAMPAIGN FORM	
OWNER:		SERV. DLE. ACCT. NO.	VEH. VIN. NO.	SALE CODE	RECALL CAMPAIGN NO.
OWNER'S SIGNATURE		QUOTA NO. 4101	SPRINT R. ACC. NO.	REPAIR DATE / /	RE-LOG.
CLAIMS PAID SUBJECT TO AUDIT AND PARTS INSPECTION		NO. VERIFY THE COMPLETION OF ALL REPAIRS REQUIREMENTS UNDER THIS MODEL CAMPAIGN ON THIS VEHICLE		OPER. NO.	REQUIRE
AUTHORIZED SIGNING DEPARTMENT		SIGNATURE		RECALL CAMPAIGN AMOUNT CALCULATIONS	
FACTORY QUALITY		REJECT		PARTS CENTER	
RETURN		SUBJECT		AMOUNT CLAIMED	

FACTORY COPY



NO POSTAGE
NECESSARY
IF MAILED
IN THE
UNITED STATES

BUSINESS REPLY MAIL
FIRST CLASS MAIL PERMIT NO. 1394 ENGLEWOOD CLIFFS, NJ

POSTAGE WILL BE PAID BY ADDRESSEE

FERRARI NORTH AMERICA INC
250 SYLVAN AVE
ENGLEWOOD CLIFFS NJ 07632-9987



RECALL CAMPAIGN

REF. NO. 147
FUEL INJECTION LINES

REF. NO. 148
UPPER STEERING COLUMN
LOCKNUT

REF. NO. 149
STEERING BOX EXTENSION
FASTENER

JUNE 1992

READ, INITIAL
AND PASS ON >

Service Manager	Parts Manager	Service Writer	Technician				Warranty Clerk

TABLE OF CONTENTS

<u>TITLE</u>	<u>PAGE</u>
Letter to the Ferrari Dealer	2 - 3
<u>Recall Ref. No. 147</u> 348 ts/tb - Mondial t cpe. / cab. Fuel injection lines	4 - 8
<u>Recall Ref. No. 148</u> 348 ts/tb, Mondial t cpe. / cab. & Testarossa Upper steering column locknut	10 - 11
<u>Recall Ref. No. 149</u> 348 ts/tb Steering box extension fastener	12 - 13
Recall Claim form instructions	14 - 15
Letters to the Customer	16 - 29
Vehicle Master List	30 - 49

Ferrari

Ferrari North America, Inc.
250 Sylvan Avenue
Englewood Cliffs, NJ 07632
201-816-2600
TLX: 8182616
FAX: 201-816-2626

June 1992

Dear Ferrari Dealer:

Ferrari S.p.A., the manufacturer of Ferrari automobiles, has determined that certain defects exist in certain 1989, 1990 and 1991 model year Ferrari vehicles.



- 1) On 348 ts/tb and Mondial t vehicles with Vehicle Identification Number lower than 88386, the aluminum fittings on certain *fuel injection lines* can corrode under extreme environmental conditions. Should such condition remain unnoticed, the result could be breakage of the aluminum fuel line fitting resulting in fuel leakage. As with any type of fuel system leakage, the possibility of a vehicle engine fire may exist.
- 2) On 348 ts/tb, Mondial t, and Testarossa vehicles with Vehicle Identification Number lower than 87898, the *upper steering column locknut* was manufactured with a lower class of material and self-locking properties. This may result in a loss of tightening torque on the upper steering column fastener. Should such condition remain unnoticed and the use of the car be prolonged for an extensive period of time, loosening of the fastener could occur resulting in play in the steering system and consequential impairment of handling.
- 3) On 348 ts/tb vehicles with Vehicle Identification Number lower than 86232, the *steering box extension fastener* was manufactured with a lower class of material and self-locking properties. This may result in a loss of tightening torque on the upper steering column fastener. Should such condition remain unnoticed and the use of the car be prolonged for an extensive period of time, loosening of the fastener could occur resulting in play in the steering system and consequential impairment of handling.

Instructions for performing the necessary remedies are herewith enclosed. The corrective action will require approximately 1.5 hours.

Accordingly, we have sent notices to all owners of the potentially affected vehicles advising them of these problems and requesting that they contact any authorized Ferrari dealer for the necessary repairs, as per the attached notification letter.

Cont.....



Upon receipt of the campaign notice properly signed by the customer and by you or your authorized representative, we will, of course, reimburse you for the labor and applicable parts expended in carrying out these campaigns.

Obviously, if you have any of the potentially affected vehicles in your stock, you must not sell them until you have performed the necessary repairs. If you have already sold any vehicles with the chassis number specified in the enclosed instructions and have not yet sent in the retail sales cards, please do so at once so we may notify these owners.

Thank you for your cooperation.
Very truly yours,

A handwritten signature in black ink that reads "Kenneth McCay". The signature is written in a cursive, slightly slanted style.

Kenneth McCay
Technical Director
Ferrari North America, Inc.

RECALL CAMPAIGN NO. 147

INTRODUCTION - Fuel injection lines

- SUBJECT:** Recall Campaign No. 147
Ferrari 348 ts/tb - Mondial t Models - Fuel injection lines
- VEHICLES:** All Ferrari 348 ts/tb and Mondial t Models with the following serial number ranges:
- Ferrari 348 ts/tb, Model Year 1989 and 1990, starting from serial number 82277 up to serial number 87888 included.
 - Ferrari Mondial t coupe and cabriolet, Model Year 1989 and 1990, starting from serial number 81342 up to serial number 87908 included.
- CONDITION:** The aluminum fuel line fittings on certain fuel Injection lines may corrode under extreme environmental conditions. Should such condition remain unnoticed, the result could be breakage of the aluminum fuel line fitting resulting in fuel leakage.
- REMEDY:** Replacement of the Fuel injection system lines "A & B" with the modified fuel lines (shown on Fig 1, page 6).
- PARTS:** Quantities required for each vehicle and identification of the new Fuel lines with the new part numbers, are shown on the Parts List Table "A" on Page 8). The new part fittings are now aluminum with a non corrosive coating.
- COST:**
- a) An initial supply of new fuel lines will be shipped to your dealership. Your parts account will be charged accordingly. The Table on page 8 indicates the part numbers and quantity required per vehicle.
 - b) Additional fuel return lines can be ordered from the Ferrari North America Parts Department in Englewood Cliffs, New Jersey.
- LABOR:**
- | | |
|---------------|-----------------------|
| Operation No. | 147 |
| Time | 348 ts/tb - 0.8 hours |
| | Mondial t - 1.2 hours |

RECALL CAMPAIGN NO. 148

INTRODUCTION - Upper steering column locknut

SUBJECT: Recall Campaign No. 148
Ferrari 348 ts/tb, Mondial t and Testarossa Models
Upper steering column locknut

VEHICLES: All Ferrari 348 ts/tb, Mondial t & Testarossa Models with the following serial number ranges:

- Ferrari 348 ts/tb, Model Year 1990 and 1991, starting from serial number 85389 up to serial number 87898 included.
- Ferrari Mondial t coupe and cabriolet, Model Year 1990, starting from serial number 85927 up to serial number 87908 included.
- Ferrari Testarossa, Model Year 1990 and 1991, starting from serial number 85658 up to serial number 87483 included.

CONDITION: The *upper steering column locknut* may have been manufactured with a lower class of material and self-locking properties. This may result in a loss of tightening torque on the upper steering column fastener. Should such condition remain unnoticed and the use of the car be prolonged for an extensive period of time, loosening of the fastener could occur resulting in play in the steering system and consequential impairment of handling.

REMEDY: Replacement of the Upper steering column locknut with the improved self-locking nut (shown on Fig 1, page 11).

PARTS: Only one locknut (PN# 150428) required for each vehicle.

COST: An initial supply of new self-locking nuts will be shipped to your dealership. Your parts account will be charged accordingly. Additional self-locking nuts can be ordered from the Ferrari North America Parts Department in Englewood Cliffs, New Jersey.

LABOR: Operation No. 148
Time ALL MODELS - 0.2 hours

REIMBURSEMENT: On receipt of the correctly completed recall campaign claim (see Recall Claim form Instructions, page x).

INSTRUCTIONS FOR LOCKNUT REPLACEMENT

- A. Preliminary: The replacement self-locking nut (Fig.#1a) is supplied as a spare part (PN# 150428) by the Ferrari North America parts department.
- B. Procedure for installation
- 1) Cover interior (seat and carpeting).
 - 2) Remove 13mm locknut from upper steering column fastener and replace with new 13mm self locking nut (PN# 150428) as shown in fig.# 1 below.
 - 3) Check that the steering column shaft is properly inserted into the steering column extension. Fastener must go through the groove provided in the steering column shaft.
 - 4) Torque self-locking nut to 2.3 daNm (17 lbs/ft).
 - 5) Check for binding in steering system. If there is binding, check system for faults.
 - 6) Remove all protective covers from interior and insure that the area is clean.

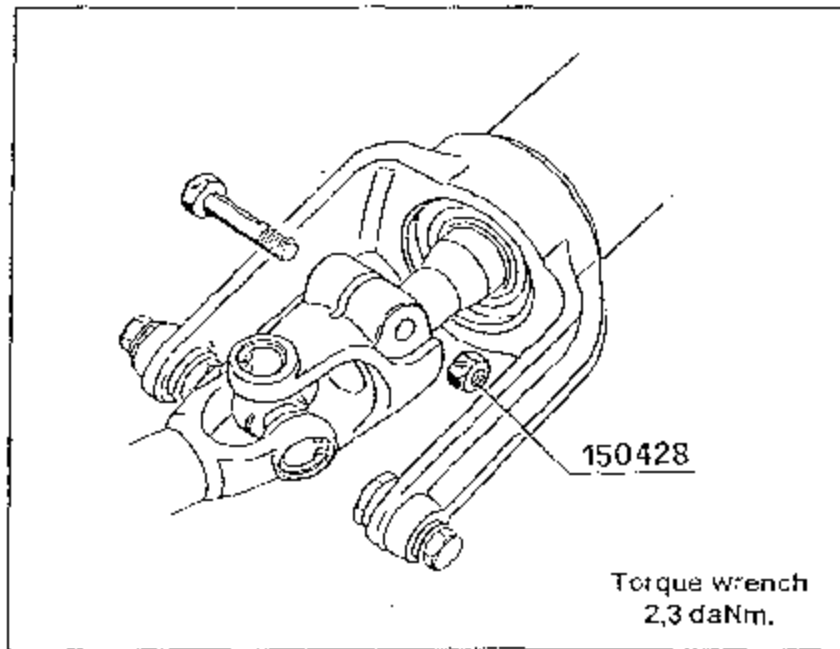

Fig.#1a

RECALL CAMPAIGN NO. 149

INTRODUCTION - Steering box extension fastener

SUBJECT: Recall Campaign No. 149
Ferrari 348 ts/tb Models
Steering box extension fastener

VEHICLES: All Ferrari 348 ts/tb Models with the following serial number ranges:

- Ferrari 348 ts/tb, Model Year 1989 and 1990, starting from serial number 82277 up to serial number 86212 included.

CONDITION: On 348 ts/tb vehicles with Vehicle Identification Number lower than 86212, the *steering box extension fastener* may have been manufactured with a lower class of material and self-locking properties. This may result in a loss of tightening torque on the upper steering column fastener. Should such condition remain unnoticed and the use of the car be prolonged for an extensive period of time, loosening of the fastener could occur resulting in play in the steering system and consequential impairment of handling.

REMEDY: Replacement of the Steering box extension fastener with the improved fastener (shown on Fig 1, page 13).

PARTS: One set of the following is required for each vehicle:

- | | | |
|------------------|-------------|--------------|
| a) Fastener bolt | PN#125518 | Quantity - 1 |
| b) Locknut | PN#12574221 | Quantity - 1 |
| c) Washer | PN#12601274 | Quantity - 2 |

COST: An initial supply of these parts will be shipped to your dealership. Your parts account will be charged accordingly. Additional supplies of these parts can be ordered from the Ferrari North America Parts Department in Englewood Cliffs, New Jersey.

LABOR: Operation No. 149
Time 0.1 hours

REIMBURSEMENT: On receipt of the correctly completed recall campaign claim (see Recall Claim form Instructions, page x).

INSTRUCTIONS FOR FASTENER REPLACEMENT

- A. Preliminary: The replacement Fastener, bolt and washers (Fig.#1) are supplied as a spare parts by the Ferrari North America parts department using the part numbers listed on "parts" section of page 12.
- B. Procedure for installation
- 1) Cover interior (seat and carpeting).
 - 2) Move carpeting away from area of steering extension located under the dash at the base of the front cabin wall.
 - 3) Remove 10mm locknut from steering extension fastener and remove the fastener.
 - 4) Check that the steering box shaft is properly inserted into the steering column extension. Fastener must go through the groove provided in the steering box shaft.
 - 5) Install new fastening bolt along with the two washers and locknut as shown in fig.# 1 below.
 - 6) Torque Fastener nut to 1.2 daNm (9 lbs/ft).
 - 7) Replace carpeting around area of steering extension.
 - 8) Check for binding in steering system. If there is binding, check system for faults.
 - 9) Remove all protective covers from interior and insure that the area is clean.

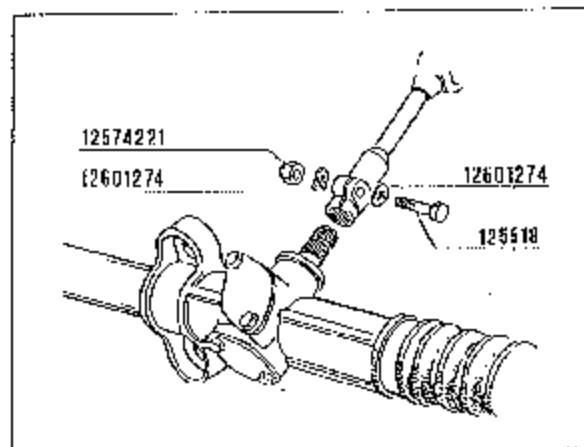

Fig.#1b

RECALL CLAIM FORM INSTRUCTIONS

FORWARD: The enclosed recall claim form has been numbered in these areas to be completed by your dealership. The numbered areas indicate the necessary information needed to process the claim and promptly credit your account.

INSTRUCTIONS: Information required to complete the recall claim form:

<u>Area</u>	<u>Instructions</u>
--------------------	----------------------------

- 1) Enter your Ferrari 4-digit account number.
- 2) Enter vehicle mileage at time of repair.
- 3) Enter date of repair.
- 4) Enter Dealer claim calculations:

Parts Dealer Net (Stock order price) Parts Handling (33%) Total Parts Total Labor (hrs. x your approved WAR) Amount Claimed
--
- 5) Enter name of authorized servicing Dealer.
- 6) Signature of Dealer or authorized designee.
- 7) Signature of vehicle's owner.
- 8) If VIN number listed in area 8 appears invalid, please show correct VIN in explanation space (9).

No repair order need be attached for the campaign unless an owner has lost or never received a recall claim form. If this occurs, record all pertinent data, as required by the recall claim form, on a repair order. **Owner signs the repair order.**

The repair order must not be submitted until the Ferrari Representative can provide a blank recall claim form. Transfer pertinent data from repair order to the recall claim form. In OWNER area (7), write "Owner's signature on repair order no. ." **Attach the repair order to the claim form** and submit for reimbursement.

MAILING: Send the recall claim form to the Ferrari North America Warranty department in a Warranty claim return envelope (Part No. 3555).



NORTH AMERICA, INC.

DOCUMENT NUMBER FOR FACTORY USE ONLY

RECALL CAMPAIGN FORM

COPY #1 RETURN TO FACTORY		COPY #2 DEALER COPY RETAIN FOR YOUR RECORDS		COPY #3 PARTS COPY RETAIN WITH PARTS		COPY #4 PNA TECHNICIAN MANAGER	
OWNER:		SERV. DLR ACCT. NO. 1		VEH. VIN. NO. 8		RECALL CAMPAIGN NO.	
OWNER'S SIGNATURE: 7		CLAIMING		SELL. DLR. ACCT. NO.		RECALL CODE	
CLAIMS PAID SUBJECT TO AUDIT AND PARTS SPECIFICATION		NO. / 3 /		DEPARTMENT / /		MILEAGE 2	
WE CERTIFY THE COMPLETION OF SERVICES REQUISITE UNDER THE RECALL CAMPAIGN ON THIS VEHICLE		FACTORY COMMENTS		OPER. NO.		HOURS	
ALT-ORZED SERVICING DEALER NAME 5		SIGNATURE 6		DEALER CLAIM CALCULATIONS		AMOUNT CLAIMED	
REJECT <input type="checkbox"/>		RETURN <input type="checkbox"/>		PARTS DEALER NET		TOTAL PARTS	
TOTAL PARTS		TOTAL LABOR		TOTAL		TOTAL	
TOTAL		TOTAL		TOTAL		TOTAL	

Form No 3140

Ferrari

Ferrari North America, Inc.
250 Sylvan Avenue
Englewood Cliffs, NJ 07632
201-816-2600
TLX: 8162616
FAX: 201-816-2626

June 1992

Letter "A"

This notice is sent to you in accordance with the requirements of the National Traffic and Motor Vehicles Safety Act.

Ferrari S.p.A., the manufacturer of Ferrari automobiles, has determined that certain defects exist in certain 1989 and 1990 model year Ferrari vehicles.

- 1) On 348 ts/tb vehicles with Vehicle Identification Number lower than 88386, the aluminum fittings on certain *fuel Injection lines* can corrode under extreme environmental conditions. Should such condition remain unnoticed, the result could be breakage of the aluminum fuel line fitting resulting in fuel leakage. As with any type of fuel system leakage, the possibility of a vehicle engine fire may exist.
- 2) On 348 ts/tb vehicles with Vehicle Identification Number lower than 86232, the *steering box extension fastener* was manufactured with a lower class of material and self-locking properties. This may result in a loss of tightening torque on the upper steering column fastener. Should such condition remain unnoticed and the use of the car be prolonged for an extensive period of time, loosening of the fastener could occur resulting in play in the steering system and consequential impairment of handling.

Since your car is among those potentially affected by the above conditions, we kindly ask you to contact any Ferrari Authorized Dealer immediately in order to arrange an inspection of your automobile, and if necessary, the Dealer will perform the required modifications.

The corrective action for the above listed repairs will be performed free of charge and will require approximately 1.5 hours, however please plan to leave your vehicle with the dealer all day to allow the dealer some flexibility for scheduling your repairs.

By the time you receive this letter, the Authorized Ferrari Dealer will have been supplied with the instructions and parts to perform the repairs.





Also, Ferrari S.p.A. has introduced a number of improvements into production that may be applicable to your vehicle. While your vehicle is at your Ferrari authorized dealer for the above listed recall campaign items, we would like the opportunity to extend these improvements to your car free of charge.

If the Dealer fails or is unable to make the necessary repairs free of charge within a reasonable time, you should inform the National Headquarters Office of Ferrari North America, Inc.

250 Sylvan Avenue,
Englewood Cliffs, NJ 07632
(201) 816-2651 (National Technical Office)
(201) 816-2652 (Customer Relations)

Although we urge you to immediately call one of the numbers indicated above, if the vehicle is not repaired free of charge or within a reasonable time, you may also contact the Administrator of the National Traffic Safety Administration in Washington, D.C. 20590 or call the Auto Safety Hot line at 1-800-424-9393 nationally and (202) 366-0123 for Washington D.C. area residents.

We urge you to comply with this notice promptly and we apologize for any inconvenience this may cause you.

Sincerely,

A handwritten signature in black ink that reads "Kenneth McCay". The signature is written in a cursive, slightly slanted style.

Kenneth McCay
Technical Director
Ferrari North America, Inc.

Ferrari

Ferrari North America, Inc.
250 Sylvan Avenue
Englewood Cliffs, NJ 07632
201-816-2000
TLX: 8182618
FAX: 201-816-2628

June 1992

Letter "B"

This notice is sent to you in accordance with the requirements of the National Traffic and Motor Vehicles Safety Act.

Ferrari S.p.A., the manufacturer of Ferrari automobiles, has determined that certain defects exist in certain 1990 model year Ferrari vehicles.



- 1) On 348 ts/tb vehicles with Vehicle Identification Number lower than 88386, the aluminum fittings on certain *fuel injection lines* can corrode under extreme environmental conditions. Should such condition remain unnoticed, the result could be breakage of the aluminum fuel line fitting resulting in fuel leakage. As with any type of fuel system leakage, the possibility of a vehicle engine fire may exist.
- 2) On 348 ts/tb vehicles with Vehicle Identification Number lower than 87898, the *upper steering column locknut* was manufactured with a lower class of material and self-locking properties. This may result in a loss of tightening torque on the upper steering column fastener. Should such condition remain unnoticed and the use of the car be prolonged for an extensive period of time, loosening of the fastener could occur resulting in play in the steering system and consequential impairment of handling.
- 3) On 348 ts/tb vehicles with Vehicle Identification Number lower than 86232, the *steering box extension fastener* was manufactured with a lower class of material and self-locking properties. This may result in a loss of tightening torque on the steering box extension fastener. Should such condition remain unnoticed and the use of the car be prolonged for an extensive period of time, loosening of the fastener could occur resulting in play in the steering system and consequential impairment of handling.

Since your car is among those potentially affected by the above conditions, we kindly ask you to contact any Ferrari Authorized Dealer immediately in order to arrange an inspection of your automobile, and if necessary, the Dealer will perform the required modifications.

The corrective action for the above listed repairs will be performed free of charge and will require approximately 1.5 hours, however please plan to leave your vehicle with the dealer all day to allow the dealer some flexibility for scheduling your repairs.



By the time you receive this letter, the Authorized Ferrari Dealer will have been supplied with the instructions and parts to perform the repairs.

Also, Ferrari S.p.A. has introduced a number of improvements into production that may be applicable to your vehicle. While your vehicle is at your Ferrari authorized dealer for the above listed recall campaign items, we would like the opportunity to extend these improvements to your car free of charge.

If the Dealer fails or is unable to make the necessary repairs free of charge within a reasonable time, you should inform the National Headquarters Office of Ferrari North America, Inc.

250 Sylvan Avenue,
Englewood Cliffs, NJ 07632
(201) 816-2651 (National Technical Office)
(201) 816-2652 (Customer Relations)

Although we urge you to immediately call one of the numbers indicated above, if the vehicle is not repaired free of charge or within a reasonable time, you may also contact the Administrator of the National Traffic Safety Administration in Washington, D.C. 20590 or call the Auto Safety Hot line at 1-800-424-9393 nationally and (202) 366-0123 for Washington D.C. area residents.

We urge you to comply with this notice promptly and we apologize for any inconvenience this may cause you.

Sincerely,

Kenneth McCay
Technical Director
Ferrari North America, Inc.

Ferrari

Ferrari North America, Inc.
250 Sylvan Avenue
Englewood Cliffs, NJ 07632
201-816-2600
TLX: 8162616
FAX: 201-816-2626

June 1992

Letter "C"

This notice is sent to you in accordance with the requirements of the National Traffic and Motor Vehicles Safety Act.

Ferrari S.p.A., the manufacturer of Ferrari automobiles, has determined that certain defects exist in certain 1990 model year Ferrari vehicles.

- 1) On 348 ts/tb vehicles with Vehicle Identification Number lower than 88386, the aluminum fittings on certain *fuel Injection lines* can corrode under extreme environmental conditions. Should such condition remain unnoticed, the result could be breakage of the aluminum fuel line fitting resulting in fuel leakage. As with any type of fuel system leakage, the possibility of a vehicle engine fire may exist.
- 2) On 348 ts/tb vehicles with Vehicle Identification Number lower than 87898, the *upper steering column locknut* was manufactured with a lower class of material and self-locking properties. This may result in a loss of tightening torque on the upper steering column fastener. Should such condition remain unnoticed and the use of the car be prolonged for an extensive period of time, loosening of the fastener could occur resulting in play in the steering system and consequential impairment of handling.

Since your car is among those potentially affected by the above conditions, we kindly ask you to contact any Ferrari Authorized Dealer immediately in order to arrange an inspection of your automobile, and if necessary, the Dealer will perform the required modifications.

The corrective action for the above listed repairs will be performed free of charge and will require approximately 1.5 hours, however please plan to leave your vehicle with the dealer all day to allow the dealer some flexibility for scheduling your repairs.

By the time you receive this letter, the Authorized Ferrari Dealer will have been supplied with the instructions and parts to perform the repairs.

Also, Ferrari S.p.A. has introduced a number of improvements into production that may be applicable to your vehicle. While your vehicle is at your Ferrari authorized dealer for the above listed recall campaign items, we would like the opportunity to extend these improvements to your car free of charge.



If the Dealer fails or is unable to make the necessary repairs free of charge within a reasonable time, you should inform the National Headquarters Office of Ferrari North America, Inc.

250 Sylvan Avenue,
Englewood Cliffs, NJ 07632
(201) 816-2651 (National Technical Office)
(201) 816-2652 (Customer Relations)

Although we urge you to immediately call one of the numbers indicated above, if the vehicle is not repaired free of charge or within a reasonable time, you may also contact the Administrator of the National Traffic Safety Administration in Washington, D.C. 20590 or call the Auto Safety Hot line at 1-800-424-9393 nationally and (202) 366-0123 for Washington D.C. area residents.

We urge you to comply with this notice promptly and we apologize for any inconvenience this may cause you.

Sincerely,

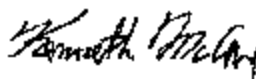

Kenneth McCay
Technical Director
Ferrari North America, Inc.



Ferrari

Ferrari North America, Inc.
250 Sylvan Avenue
Englewood Cliffs, NJ 07632
201 816-2600
TLX: 8162616
FAX: 201-816-2626

June 1992

Letter "D"

This notice is sent to you in accordance with the requirements of the National Traffic and Motor Vehicles Safety Act.

Ferrari S.p.A., the manufacturer of Ferrari automobiles, has determined that certain defects exist in certain 1990 and 1991 model year Ferrari vehicles.

On 348 ts/tb vehicles with Vehicle Identification Number lower than 87893, the *upper steering column locknut* was manufactured with a lower class of material and self-locking properties. This may result in a loss of tightening torque on the upper steering column fastener. Should such condition remain unnoticed and the use of the car be prolonged for an extensive period of time, loosening of the fastener could occur resulting in play in the steering system and consequential impairment of handling.

Since your car is among those potentially affected by the above condition, we kindly ask you to contact any Ferrari Authorized Dealer immediately in order to arrange an inspection of your automobile, and if necessary, the Dealer will perform the required modification.

The corrective action for the above listed repair will be performed free of charge and will require approximately 1.5 hours, however please plan to leave your vehicle with the dealer all day to allow the dealer some flexibility for scheduling your repairs.

By the time you receive this letter, the Authorized Ferrari Dealer will have been supplied with the instructions and parts to perform the repair.

Also, Ferrari S.p.A. has introduced a number of improvements into production that may be applicable to your vehicle. While your vehicle is at your Ferrari authorized dealer for the above listed recall campaign items, we would like the opportunity to extend these improvements to your car free of charge.



If the Dealer fails or is unable to make the necessary repairs free of charge within a reasonable time, you should inform the National Headquarters Office of Ferrari North America, Inc.

250 Sylvan Avenue,
Englewood Cliffs, NJ 07632
(201) 816-2651 (National Technical Office)
(201) 816-2652 (Customer Relations)

Although we urge you to immediately call one of the numbers indicated above, if the vehicle is not repaired free of charge or within a reasonable Time, you may also contact the Administrator of the National Traffic Safety Administration in Washington, D.C. 20590 or call the Auto Safety Hot line at 1-800-424-9393 nationally and (202) 366-0123 for Washington D.C. area residents.

We urge you to comply with this notice promptly and we apologize for any inconvenience this may cause you.

Sincerely,

Kenneth McCay
Technical Director
Ferrari North America, Inc.



Ferrari

Ferrari North America, Inc.
250 Sylvan Avenue
Englewood Cliffs, NJ 07632
201-816-2600
TLX: 8162616
FAX: 201-816-2626

June 1992

Letter "E"

This notice is sent to you in accordance with the requirements of the National Traffic and Motor Vehicles Safety Act.

Ferrari S.p.A., the manufacturer of Ferrari automobiles, has determined that certain defects exist in certain 1990 and 1991 model year Ferrari vehicles.

On Testarossa vehicles with Vehicle Identification Number lower than 87483, the *upper steering column locknut* was manufactured with a lower class of material and self-locking properties. This may result in a loss of tightening torque on the upper steering column fastener. Should such condition remain unnoticed and the use of the car be prolonged for an extensive period of time, loosening of the fastener could occur resulting in play in the steering system and consequential impairment of handling.

Since your car is among those potentially affected by the above condition, we kindly ask you to contact any Ferrari Authorized Dealer immediately in order to arrange an inspection of your automobile, and if necessary, the Dealer will perform the required modification.

The corrective action for the above listed repair will be performed free of charge and will require approximately 1.5 hours, however please plan to leave your vehicle with the dealer all day to allow the dealer some flexibility for scheduling your repair.

By the time you receive this letter, the Authorized Ferrari Dealer will have been supplied with the instructions and parts to perform the repair.

If the Dealer fails or is unable to make the necessary repair free of charge within a reasonable time, you should inform the National Headquarters Office of Ferrari North America, Inc.

250 Sylvan Avenue,
Englewood Cliffs, NJ 07632
(201) 816-2651 (National Technical Office)
(201) 816-2652 (Customer Relations)



Although we urge you to immediately call one of the numbers indicated above, if the vehicle is not repaired free of charge or within a reasonable Time, you may also contact the Administrator of the National Traffic Safety Administration in Washington, D.C. 20590 or call the Auto Safety Hot line at 1-800-424-9393 nationally and (202) 366-0123 for Washington D.C. area residents.

We urge you to comply with this notice promptly and we apologize for any inconvenience this may cause you.

Sincerely,

Kenneth McCay
Technical Director
Ferrari North America, Inc.



Ferrari

Ferrari North America, Inc.
250 Sylvan Avenue
Englewood Cliffs, NJ 07632
201-816-2600
TLX: 8162616
FAX: 201-816-2626

June 1992

Letter "F"

This notice is sent to you in accordance with the requirements of the National Traffic and Motor Vehicles Safety Act.

Ferrari S.p.A., the manufacturer of Ferrari automobiles, has determined that certain defects exist in certain 1990 model year Ferrari vehicles.

On Mondial t coupe / cabriolet vehicles with Vehicle Identification Number lower than 88386, the aluminum fittings on certain *fuel Injection lines* can corrode under extreme environmental conditions. Should such condition remain unnoticed, the result could be breakage of the aluminum fuel line fitting resulting in fuel leakage. As with any type of fuel system leakage, the possibility of a vehicle engine fire may exist.

Since your car is among those potentially affected by the above condition, we kindly ask you to contact any Ferrari Authorized Dealer immediately in order to arrange an inspection of your automobile, and if necessary, the Dealer will perform the required modification.

The corrective action for the above listed repair will be performed free of charge and will require approximately 1.5 hours, however please plan to leave your vehicle with the dealer all day to allow the dealer some flexibility for scheduling your repair.

By the time you receive this letter, the Authorized Ferrari Dealer will have been supplied with the instructions and parts to perform the repair.

If the Dealer fails or is unable to make the necessary repair free of charge within a reasonable time, you should inform the National Headquarters Office of Ferrari North America, Inc.

250 Sylvan Avenue,
Englewood Cliffs, NJ 07632
(201) 816-2651 (National Technical Office)
(201) 816-2652 (Customer Relations)

CONL.....



Although we urge you to immediately call one of the numbers indicated above, if the vehicle is not repaired free of charge or within a reasonable Time, you may also contact the Administrator of the National Traffic Safety Administration in Washington, D.C. 20590 or call the Auto Safety Hot line at 1-800-424-9393 nationally and (202) 366-0123 for Washington D.C. area residents.

We urge you to comply with this notice promptly and we apologize for any inconvenience this may cause you.

Sincerely,

Kenneth McCay
Technical Director
Ferrari North America, Inc.



Ferrari

Ferrari North America, Inc.
250 Sylvan Avenue
Englewood Cliffs, NJ 07632
201-816-2600
TLX: 8162616
FAX: 201-816-2626

June 1992

Letter "G"

This notice is sent to you in accordance with the requirements of the National Traffic and Motor Vehicles Safety Act.



Ferrari S.p.A., the manufacturer of Ferrari automobiles, has determined that certain defects exist in certain 1990 model year Ferrari vehicles.

- 1) On Mondial t coupe / cabriolet vehicles with Vehicle Identification Number lower than 88386, the aluminum fittings on certain *fuel Injection lines* can corrode under extreme environmental conditions. Should such condition remain unnoticed, the result could be breakage of the aluminum fuel line fitting resulting in fuel leakage. As with any type of fuel system leakage, the possibility of a vehicle engine fire may exist.
- 2) On Mondial t coupe / cabriolet vehicles with Vehicle Identification Number lower than 87908, the *upper steering column locknut* was manufactured with a lower class of material and self-locking properties. This may result in a loss of tightening torque on the upper steering column fastener. Should such condition remain unnoticed and the use of the car be prolonged for an extensive period of time, loosening of the fastener could occur resulting in play in the steering system and consequential impairment of handling.

Since your car is among those potentially affected by the above conditions, we kindly ask you to contact any Ferrari Authorized Dealer immediately in order to arrange an inspection of your automobile, and if necessary, the Dealer will perform the required modifications.

The corrective action for the above listed repairs will be performed free of charge and will require approximately 1.5 hours, however please plan to leave your vehicle with the dealer all day to allow the dealer some flexibility for scheduling your repairs.

By the time you receive this letter, the Authorized Ferrari Dealer will have been supplied with the instructions and parts to perform the repairs.

If the Dealer fails or is unable to make the necessary repairs free of charge within a reasonable time, you should inform the National Headquarters Office of Ferrari North America, Inc.

250 Sylvan Avenue,
Englewood Cliffs, NJ 07632
(201) 816-2651 (National Technical Office)
(201) 816-2652 (Customer Relations)

Although we urge you to immediately call one of the numbers indicated above, if the vehicle is not repaired free of charge or within a reasonable Time, you may also contact the Administrator of the National Traffic Safety Administration in Washington, D.C. 20590 or call the Auto Safety Hot line at 1-800-424-9393 nationally and (202) 366-0123 for Washington D.C. area residents.

We urge you to comply with this notice promptly and we apologize for any inconvenience this may cause you.

Sincerely,



Kenneth McCay
Technical Director
Ferrari North America, Inc.

VEHICLE MASTER LIST

1989 348 ts / tb

<i>Serial Number</i>	<i>Model</i>	<i>Year</i>	<i>Letter</i>	<i>Recall #147</i>	<i>Recall #148</i>	<i>Recall #149</i>
82277	ts	89	"A"	Yes	No	Yes
82281	ts	89	"A"	Yes	No	Yes
82292	ts	89	"A"	Yes	No	Yes
82301	ts	89	"A"	Yes	No	Yes
82311	ts	89	"A"	Yes	No	Yes
82314	ts	89	"A"	Yes	No	Yes
82321	ts	89	"A"	Yes	No	Yes
82325	ts	89	"A"	Yes	No	Yes
82330	ts	89	"A"	Yes	No	Yes
82333	ts	89	"A"	Yes	No	Yes
82337	ts	89	"A"	Yes	No	Yes
82347	tb	89	"A"	Yes	No	Yes
82353	tb	89	"A"	Yes	No	Yes
82360	tb	89	"A"	Yes	No	Yes
82365	tb	89	"A"	Yes	No	Yes
82371	tb	89	"A"	Yes	No	Yes
82375	tb	89	"A"	Yes	No	Yes
82386	tb	89	"A"	Yes	No	Yes
82391	ts	89	"A"	Yes	No	Yes
82395	tb	89	"A"	Yes	No	Yes
82399	ts	89	"A"	Yes	No	Yes
82407	tb	89	"A"	Yes	No	Yes
82414	ts	89	"A"	Yes	No	Yes
82418	tb	89	"A"	Yes	No	Yes
82426	tb	89	"A"	Yes	No	Yes
82436	ts	89	"A"	Yes	No	Yes
82449	tb	89	"A"	Yes	No	Yes
82453	ts	89	"A"	Yes	No	Yes
82460	tb	89	"A"	Yes	No	Yes
82464	tb	89	"A"	Yes	No	Yes
82468	ts	89	"A"	Yes	No	Yes
82535	tb	89	"A"	Yes	No	Yes
82536	ts	89	"A"	Yes	No	Yes
82539	ts	89	"A"	Yes	No	Yes
82541	ts	89	"A"	Yes	No	Yes
82545	tb	89	"A"	Yes	No	Yes
82555	ts	89	"A"	Yes	No	Yes
82557	ts	89	"A"	Yes	No	Yes
82561	ts	89	"A"	Yes	No	Yes
82565	ts	89	"A"	Yes	No	Yes
82569	ts	89	"A"	Yes	No	Yes
82576	ts	89	"A"	Yes	No	Yes
82578	tb	89	"A"	Yes	No	Yes
82585	ts	89	"A"	Yes	No	Yes
82589	ts	89	"A"	Yes	No	Yes
82590	ts	89	"A"	Yes	No	Yes
82591	ts	89	"A"	Yes	No	Yes
82592	tb	89	"A"	Yes	No	Yes
82593	ts	89	"A"	Yes	No	Yes
82594	ts	89	"A"	Yes	No	Yes

<u>Serial Number</u>	<u>Model</u>	<u>Year</u>	<u>Letter</u>	<u>Recall #147</u>	<u>Recall #148</u>	<u>Recall #149</u>
82595	ts	89	" A "	Yes	No	Yes
82596	ts	89	" A "	Yes	No	Yes
82597	ts	89	" A "	Yes	No	Yes
82598	tb	89	" A "	Yes	No	Yes
82599	ts	89	" A "	Yes	No	Yes
82600	ts	89	" A "	Yes	No	Yes
82601	ts	89	" A "	Yes	No	Yes
82607	ts	89	" A "	Yes	No	Yes
82608	ts	89	" A "	Yes	No	Yes
82609	ts	89	" A "	Yes	No	Yes
82610	ts	89	" A "	Yes	No	Yes
82611	ts	89	" A "	Yes	No	Yes
82612	ts	89	" A "	Yes	No	Yes
82613	ts	89	" A "	Yes	No	Yes
82614	ts	89	" A "	Yes	No	Yes
82615	ts	89	" A "	Yes	No	Yes
82616	ts	89	" A "	Yes	No	Yes
82617	ts	89	" A "	Yes	No	Yes
82618	ts	89	" A "	Yes	No	Yes
82619	ts	89	" A "	Yes	No	Yes
82620	ts	89	" A "	Yes	No	Yes
82621	ts	89	" A "	Yes	No	Yes
82629	ts	89	" A "	Yes	No	Yes
82630	ts	89	" A "	Yes	No	Yes
82631	ts	89	" A "	Yes	No	Yes
82632	ts	89	" A "	Yes	No	Yes
82633	ts	89	" A "	Yes	No	Yes
82634	tb	89	" A "	Yes	No	Yes
82635	ts	89	" A "	Yes	No	Yes
82636	ts	89	" A "	Yes	No	Yes
82637	ts	89	" A "	Yes	No	Yes
82638	ts	89	" A "	Yes	No	Yes
82639	tb	89	" A "	Yes	No	Yes
82640	ts	89	" A "	Yes	No	Yes
82641	ts	89	" A "	Yes	No	Yes
82642	ts	89	" A "	Yes	No	Yes
82643	tb	89	" A "	Yes	No	Yes
82651	ts	89	" A "	Yes	No	Yes
82652	ts	89	" A "	Yes	No	Yes
82653	ts	89	" A "	Yes	No	Yes
82654	ts	89	" A "	Yes	No	Yes
82655	ts	89	" A "	Yes	No	Yes
82656	ts	89	" A "	Yes	No	Yes
82657	ts	89	" A "	Yes	No	Yes
82658	ts	89	" A "	Yes	No	Yes
82659	ts	89	" A "	Yes	No	Yes
82650	ts	89	" A "	Yes	No	Yes
82661	ts	89	" A "	Yes	No	Yes
82662	ts	89	" A "	Yes	No	Yes
82663	ts	89	" A "	Yes	No	Yes
82664	ts	89	" A "	Yes	No	Yes

<u>Serial Number</u>	<u>Model</u>	<u>Year</u>	<u>Letter</u>	<u>Recall #147</u>	<u>Recall #148</u>	<u>Recall #149</u>
82665	ts	89	" A "	Yes	No	Yes
82673	tb	89	" A "	Yes	No	Yes
82674	ts	89	" A "	Yes	No	Yes
82675	ts	89	" A "	Yes	No	Yes
82676	ts	89	" A "	Yes	No	Yes
82677	tb	89	" A "	Yes	No	Yes
82678	ts	89	" A "	Yes	No	Yes
82679	ts	89	" A "	Yes	No	Yes
82680	tb	89	" A "	Yes	No	Yes
82681	ts	89	" A "	Yes	No	Yes
82682	tb	89	" A "	Yes	No	Yes
82683	ts	89	" A "	Yes	No	Yes
82684	ts	89	" A "	Yes	No	Yes
82685	tb	89	" A "	Yes	No	Yes
82686	ts	89	" A "	Yes	No	Yes
82687	ts	89	" A "	Yes	No	Yes
84107	tb	89	" A "	Yes	No	Yes
84108	tb	89	" A "	Yes	No	Yes
84124	tb	89	" A "	Yes	No	Yes
84125	tb	89	" A "	Yes	No	Yes
84141	tb	89	" A "	Yes	No	Yes
84142	tb	89	" A "	Yes	No	Yes
84157	tb	89	" A "	Yes	No	Yes
84158	tb	89	" A "	Yes	No	Yes
84171	tb	89	" A "	Yes	No	Yes
84172	tb	89	" A "	Yes	No	Yes
84186	tb	89	" A "	Yes	No	Yes
84187	tb	89	" A "	Yes	No	Yes
84206	tb	89	" A "	Yes	No	Yes
84207	tb	89	" A "	Yes	No	Yes
84219	tb	89	" A "	Yes	No	Yes
84220	tb	89	" A "	Yes	No	Yes
84235	tb	89	" A "	Yes	No	Yes
1989 vehicles						
affected:				134	0	134

1990 348 ts / tb

<u>Serial Number</u>	<u>Model</u>	<u>Year</u>	<u>Letter</u>	<u>Recall #147</u>	<u>Recall #148</u>	<u>Recall #149</u>
84547	ts	90	"A"	Yes	No	Yes
84548	ts	90	"A"	Yes	No	Yes
84561	ts	90	"A"	Yes	No	Yes
84562	ts	90	"A"	Yes	No	Yes
84563	ts	90	"A"	Yes	No	Yes
84564	ts	90	"A"	Yes	No	Yes
84805	ts	90	"A"	Yes	No	Yes
85389	ts	90	"B"	Yes	Yes	Yes
85400	ts	90	"B"	Yes	Yes	Yes
85407	ts	90	"B"	Yes	Yes	Yes
85427	ts	90	"B"	Yes	Yes	Yes
85446	ts	90	"B"	Yes	Yes	Yes
85466	ts	90	"B"	Yes	Yes	Yes
85466	ts	90	"B"	Yes	Yes	Yes
85506	ts	90	"B"	Yes	Yes	Yes
85892	ts	90	"B"	Yes	Yes	Yes
85893	ts	90	"B"	Yes	Yes	Yes
85912	ts	90	"B"	Yes	Yes	Yes
85929	ts	90	"B"	Yes	Yes	Yes
85930	ts	90	"B"	Yes	Yes	Yes
85950	ts	90	"B"	Yes	Yes	Yes
85969	ts	90	"B"	Yes	Yes	Yes
85970	ts	90	"B"	Yes	Yes	Yes
85987	ts	90	"B"	Yes	Yes	Yes
86006	ts	90	"B"	Yes	Yes	Yes
86007	ts	90	"B"	Yes	Yes	Yes
86024	ts	90	"B"	Yes	Yes	Yes
86043	ts	90	"B"	Yes	Yes	Yes
86044	ts	90	"B"	Yes	Yes	Yes
86048	tb	90	"B"	Yes	Yes	Yes
86049	tb	90	"B"	Yes	Yes	Yes
86062	ts	90	"B"	Yes	Yes	Yes
86068	ts	90	"B"	Yes	Yes	Yes
86086	ts	90	"B"	Yes	Yes	Yes
86087	ts	90	"B"	Yes	Yes	Yes
86104	ts	90	"B"	Yes	Yes	Yes
86105	ts	90	"B"	Yes	Yes	Yes
86123	ts	90	"B"	Yes	Yes	Yes
86141	ts	90	"B"	Yes	Yes	Yes
86142	ts	90	"B"	Yes	Yes	Yes
86160	tb	90	"B"	Yes	Yes	Yes
86161	ts	90	"B"	Yes	Yes	Yes
86162	ts	90	"B"	Yes	Yes	Yes
86178	ts	90	"B"	Yes	Yes	Yes
86196	ts	90	"B"	Yes	Yes	Yes
86197	ts	90	"B"	Yes	Yes	Yes
86211	tb	90	"B"	Yes	Yes	Yes
86212	ts	90	"B"	Yes	Yes	Yes

<u>Serial Number</u>	<u>Model</u>	<u>Year</u>	<u>Letter</u>	<u>Recall #147</u>	<u>Recall #148</u>	<u>Recall #149</u>
86232	ts	90	"C"	Yes	Yes	No
86238	ts	90	"C"	Yes	Yes	No
86239	ts	90	"C"	Yes	Yes	No
86253	ts	90	"C"	Yes	Yes	No
86254	ts	90	"C"	Yes	Yes	No
86255	ts	90	"C"	Yes	Yes	No
86273	ts	90	"C"	Yes	Yes	No
86274	ts	90	"C"	Yes	Yes	No
86275	ts	90	"C"	Yes	Yes	No
86276	ts	90	"C"	Yes	Yes	No
86291	ts	90	"C"	Yes	Yes	No
86292	ts	90	"C"	Yes	Yes	No
86293	ts	90	"C"	Yes	Yes	No
86294	ts	90	"C"	Yes	Yes	No
86310	ts	90	"C"	Yes	Yes	No
86312	ts	90	"C"	Yes	Yes	No
86313	ts	90	"C"	Yes	Yes	No
86314	ts	90	"C"	Yes	Yes	No
86340	ts	90	"C"	Yes	Yes	No
86360	ts	90	"C"	Yes	Yes	No
86380	ts	90	"C"	Yes	Yes	No
86388	ts	90	"C"	Yes	Yes	No
86389	ts	90	"C"	Yes	Yes	No
86410	ts	90	"C"	Yes	Yes	No
86424	ts	90	"C"	Yes	Yes	No
86425	ts	90	"C"	Yes	Yes	No
86426	ts	90	"C"	Yes	Yes	No
86427	ts	90	"C"	Yes	Yes	No
86428	ts	90	"C"	Yes	Yes	No
86429	ts	90	"C"	Yes	Yes	No
86430	ts	90	"C"	Yes	Yes	No
86443	ts	90	"C"	Yes	Yes	No
86444	ts	90	"C"	Yes	Yes	No
86445	ts	90	"C"	Yes	Yes	No
86446	ts	90	"C"	Yes	Yes	No
86447	ts	90	"C"	Yes	Yes	No
86464	ts	90	"C"	Yes	Yes	No
86465	ts	90	"C"	Yes	Yes	No
86466	ts	90	"C"	Yes	Yes	No
86467	ts	90	"C"	Yes	Yes	No
86468	ts	90	"C"	Yes	Yes	No
86481	ts	90	"C"	Yes	Yes	No
86482	ts	90	"C"	Yes	Yes	No
86483	ts	90	"C"	Yes	Yes	No
86484	ts	90	"C"	Yes	Yes	No
86485	ts	90	"C"	Yes	Yes	No
86501	ts	90	"C"	Yes	Yes	No
86502	ts	90	"C"	Yes	Yes	No
86503	ts	90	"C"	Yes	Yes	No
86504	ts	90	"C"	Yes	Yes	No
86507	ts	90	"C"	Yes	Yes	No

<u>Serial Number</u>	<u>Model</u>	<u>Year</u>	<u>Letter</u>	<u>Recall #147</u>	<u>Recall #148</u>	<u>Recall #149</u>
86521	ts	90	"C"	Yes	Yes	No
86522	ts	90	"C"	Yes	Yes	No
86523	ts	90	"C"	Yes	Yes	No
86524	ts	90	"C"	Yes	Yes	No
86539	ts	90	"C"	Yes	Yes	No
86540	ts	90	"C"	Yes	Yes	No
86541	ts	90	"C"	Yes	Yes	No
86542	ts	90	"C"	Yes	Yes	No
86556	ts	90	"C"	Yes	Yes	No
86557	ts	90	"C"	Yes	Yes	No
86558	ts	90	"C"	Yes	Yes	No
86559	ts	90	"C"	Yes	Yes	No
86563	ts	90	"C"	Yes	Yes	No
86573	ts	90	"C"	Yes	Yes	No
86574	ts	90	"C"	Yes	Yes	No
86575	ts	90	"C"	Yes	Yes	No
86576	ts	90	"C"	Yes	Yes	No
86592	ts	90	"C"	Yes	Yes	No
86593	ts	90	"C"	Yes	Yes	No
86594	ts	90	"C"	Yes	Yes	No
86595	ts	90	"C"	Yes	Yes	No
86612	ts	90	"C"	Yes	Yes	No
86613	ts	90	"C"	Yes	Yes	No
86614	ts	90	"C"	Yes	Yes	No
86615	ts	90	"C"	Yes	Yes	No
86616	ts	90	"C"	Yes	Yes	No
86630	ts	90	"C"	Yes	Yes	No
86631	ts	90	"C"	Yes	Yes	No
86632	ts	90	"C"	Yes	Yes	No
86633	ts	90	"C"	Yes	Yes	No
86634	ts	90	"C"	Yes	Yes	No
86639	ts	90	"C"	Yes	Yes	No
86649	ts	90	"C"	Yes	Yes	No
86650	ts	90	"C"	Yes	Yes	No
86651	ts	90	"C"	Yes	Yes	No
86652	ts	90	"C"	Yes	Yes	No
86653	ts	90	"C"	Yes	Yes	No
86668	ts	90	"C"	Yes	Yes	No
86669	ts	90	"C"	Yes	Yes	No
86670	ts	90	"C"	Yes	Yes	No
86671	ts	90	"C"	Yes	Yes	No
86672	ts	90	"C"	Yes	Yes	No
86673	ts	90	"C"	Yes	Yes	No
86674	ts	90	"C"	Yes	Yes	No
86675	ts	90	"C"	Yes	Yes	No
86689	ts	90	"C"	Yes	Yes	No
86690	ts	90	"C"	Yes	Yes	No
86691	ts	90	"C"	Yes	Yes	No
86692	ts	90	"C"	Yes	Yes	No
86693	ts	90	"C"	Yes	Yes	No
86694	ts	90	"C"	Yes	Yes	No

<u>Serial Number</u>	<u>Model</u>	<u>Year</u>	<u>Letter</u>	<u>Recall #147</u>	<u>Recall #148</u>	<u>Recall #149</u>
86695	ts	90	"C"	Yes	Yes	No
86696	ts	90	"C"	Yes	Yes	No
86706	ts	90	"C"	Yes	Yes	No
86716	ts	90	"C"	Yes	Yes	No
86717	ts	90	"C"	Yes	Yes	No
86718	ts	90	"C"	Yes	Yes	No
86719	ts	90	"C"	Yes	Yes	No
86720	ts	90	"C"	Yes	Yes	No
86721	ts	90	"C"	Yes	Yes	No
86722	ts	90	"C"	Yes	Yes	No
86723	ts	90	"C"	Yes	Yes	No
86724	ts	90	"C"	Yes	Yes	No
86735	ts	90	"C"	Yes	Yes	No
86736	ts	90	"C"	Yes	Yes	No
86754	ts	90	"C"	Yes	Yes	No
86772	ts	90	"C"	Yes	Yes	No
86773	ts	90	"C"	Yes	Yes	No
86781	ts	90	"C"	Yes	Yes	No
86853	ts	90	"C"	Yes	Yes	No
86854	ts	90	"C"	Yes	Yes	No
86857	ts	90	"C"	Yes	Yes	No
86869	ts	90	"C"	Yes	Yes	No
86870	ts	90	"C"	Yes	Yes	No
86871	ts	90	"C"	Yes	Yes	No
86872	ts	90	"C"	Yes	Yes	No
86874	ts	90	"C"	Yes	Yes	No
86888	ts	90	"C"	Yes	Yes	No
86889	ts	90	"C"	Yes	Yes	No
86890	ts	90	"C"	Yes	Yes	No
86891	ts	90	"C"	Yes	Yes	No
86906	ts	90	"C"	Yes	Yes	No
86907	ts	90	"C"	Yes	Yes	No
86908	ts	90	"C"	Yes	Yes	No
86909	ts	90	"C"	Yes	Yes	No
86910	ts	90	"C"	Yes	Yes	No
86912	ts	90	"C"	Yes	Yes	No
86913	ts	90	"C"	Yes	Yes	No
86925	ts	90	"C"	Yes	Yes	No
86926	ts	90	"C"	Yes	Yes	No
86927	ts	90	"C"	Yes	Yes	No
86928	ts	90	"C"	Yes	Yes	No
86933	ts	90	"C"	Yes	Yes	No
86946	ts	90	"C"	Yes	Yes	No
86947	ts	90	"C"	Yes	Yes	No
86948	ts	90	"C"	Yes	Yes	No
86949	ts	90	"C"	Yes	Yes	No
86963	ts	90	"C"	Yes	Yes	No
86964	ts	90	"C"	Yes	Yes	No
86965	ts	90	"C"	Yes	Yes	No
86966	ts	90	"C"	Yes	Yes	No
86970	ts	90	"C"	Yes	Yes	No

<u>Serial Number</u>	<u>Model</u>	<u>Year</u>	<u>Letter</u>	<u>Recall #147</u>	<u>Recall #148</u>	<u>Recall #149</u>
87077	ts	90	"C"	Yes	Yes	No
87078	ts	90	"C"	Yes	Yes	No
87079	ts	90	"C"	Yes	Yes	No
87080	ts	90	"C"	Yes	Yes	No
87081	ts	90	"C"	Yes	Yes	No
87091	ts	90	"C"	Yes	Yes	No
87092	ts	90	"C"	Yes	Yes	No
87093	ts	90	"C"	Yes	Yes	No
87094	ts	90	"C"	Yes	Yes	No
87108	ts	90	"C"	Yes	Yes	No
87109	ts	90	"C"	Yes	Yes	No
87110	ts	90	"C"	Yes	Yes	No
87111	ts	90	"C"	Yes	Yes	No
87112	ts	90	"C"	Yes	Yes	No
87124	ts	90	"C"	Yes	Yes	No
87125	ts	90	"C"	Yes	Yes	No
87126	ts	90	"C"	Yes	Yes	No
87127	ts	90	"C"	Yes	Yes	No
87145	ts	90	"C"	Yes	Yes	No
87146	ts	90	"C"	Yes	Yes	No
87147	ts	90	"C"	Yes	Yes	No
87151	ts	90	"C"	Yes	Yes	No
87152	ts	90	"C"	Yes	Yes	No
87167	ts	90	"C"	Yes	Yes	No
87168	ts	90	"C"	Yes	Yes	No
87169	ts	90	"C"	Yes	Yes	No
87170	ts	90	"C"	Yes	Yes	No
87171	ts	90	"C"	Yes	Yes	No
87173	ts	90	"C"	Yes	Yes	No
87188	ts	90	"C"	Yes	Yes	No
87189	ts	90	"C"	Yes	Yes	No
87190	ts	90	"C"	Yes	Yes	No
87206	ts	90	"C"	Yes	Yes	No
87207	ts	90	"C"	Yes	Yes	No
87208	ts	90	"C"	Yes	Yes	No
87209	ts	90	"C"	Yes	Yes	No
87210	ts	90	"C"	Yes	Yes	No
87226	ts	90	"C"	Yes	Yes	No
87227	ts	90	"C"	Yes	Yes	No
87228	ts	90	"C"	Yes	Yes	No
87229	ts	90	"C"	Yes	Yes	No
87244	ts	90	"C"	Yes	Yes	No
87245	ts	90	"C"	Yes	Yes	No
87246	ts	90	"C"	Yes	Yes	No
87247	ts	90	"C"	Yes	Yes	No
87248	ts	90	"C"	Yes	Yes	No
87264	ts	90	"C"	Yes	Yes	No
87265	ts	90	"C"	Yes	Yes	No
87266	ts	90	"C"	Yes	Yes	No
87267	ts	90	"C"	Yes	Yes	No
87292	ts	90	"C"	Yes	Yes	No

<u>Serial Number</u>	<u>Model</u>	<u>Year</u>	<u>Letter</u>	<u>Recall #147</u>	<u>Recall #148</u>	<u>Recall #149</u>
87283	ts	90	"C"	Yes	Yes	No
87284	ts	90	"C"	Yes	Yes	No
87285	ts	90	"C"	Yes	Yes	No
87286	ts	90	"C"	Yes	Yes	No
87301	ts	90	"C"	Yes	Yes	No
87302	ts	90	"C"	Yes	Yes	No
87303	ts	90	"C"	Yes	Yes	No
87319	ts	90	"C"	Yes	Yes	No
87320	ts	90	"C"	Yes	Yes	No
87321	ts	90	"C"	Yes	Yes	No
87322	ts	90	"C"	Yes	Yes	No
87339	ts	90	"C"	Yes	Yes	No
87340	ts	90	"C"	Yes	Yes	No
87341	ts	90	"C"	Yes	Yes	No
87342	ts	90	"C"	Yes	Yes	No
87357	ts	90	"C"	Yes	Yes	No
87358	ts	90	"C"	Yes	Yes	No
87359	ts	90	"C"	Yes	Yes	No
87360	ts	90	"C"	Yes	Yes	No
87378	ts	90	"C"	Yes	Yes	No
87379	ts	90	"C"	Yes	Yes	No
87380	ts	90	"C"	Yes	Yes	No
87381	ts	90	"C"	Yes	Yes	No
87396	ts	90	"C"	Yes	Yes	No
87397	ts	90	"C"	Yes	Yes	No
87398	ts	90	"C"	Yes	Yes	No
87413	ts	90	"C"	Yes	Yes	No
87414	ts	90	"C"	Yes	Yes	No
87415	ts	90	"C"	Yes	Yes	No
87416	ts	90	"C"	Yes	Yes	No
87431	ts	90	"C"	Yes	Yes	No
87432	ts	90	"C"	Yes	Yes	No
87433	ts	90	"C"	Yes	Yes	No
87434	ts	90	"C"	Yes	Yes	No
87450	ts	90	"C"	Yes	Yes	No
87451	ts	90	"C"	Yes	Yes	No
87452	ts	90	"C"	Yes	Yes	No
87468	ts	90	"C"	Yes	Yes	No
87469	ts	90	"C"	Yes	Yes	No
87470	ts	90	"C"	Yes	Yes	No
87471	ts	90	"C"	Yes	Yes	No
87487	ts	90	"C"	Yes	Yes	No
87488	ts	90	"C"	Yes	Yes	No
87489	ts	90	"C"	Yes	Yes	No
87490	ts	90	"C"	Yes	Yes	No
87506	ts	90	"C"	Yes	Yes	No
87507	ts	90	"C"	Yes	Yes	No
87508	ts	90	"C"	Yes	Yes	No
87509	ts	90	"C"	Yes	Yes	No
87525	ts	90	"C"	Yes	Yes	No
87526	ts	90	"C"	Yes	Yes	No

<u>Serial Number</u>	<u>Model</u>	<u>Year</u>	<u>Letter</u>	<u>Recall #147</u>	<u>Recall #148</u>	<u>Recall #149</u>
87527	ts	90	"C"	Yes	Yes	No
87528	ts	90	"C"	Yes	Yes	No
87544	ts	90	"C"	Yes	Yes	No
87545	ts	90	"C"	Yes	Yes	No
87546	ts	90	"C"	Yes	Yes	No
87547	ts	90	"C"	Yes	Yes	No
87563	ts	90	"C"	Yes	Yes	No
87564	ts	90	"C"	Yes	Yes	No
87565	ts	90	"C"	Yes	Yes	No
87566	ts	90	"C"	Yes	Yes	No
87572	ts	90	"C"	Yes	Yes	No
87573	ts	90	"C"	Yes	Yes	No
87574	ts	90	"C"	Yes	Yes	No
87575	ts	90	"C"	Yes	Yes	No
87582	ts	90	"C"	Yes	Yes	No
87583	ts	90	"C"	Yes	Yes	No
87584	ts	90	"C"	Yes	Yes	No
87585	ts	90	"C"	Yes	Yes	No
87604	ts	90	"C"	Yes	Yes	No
87605	ts	90	"C"	Yes	Yes	No
87606	ts	90	"C"	Yes	Yes	No
87607	ts	90	"C"	Yes	Yes	No
87622	ts	90	"C"	Yes	Yes	No
87623	ts	90	"C"	Yes	Yes	No
87624	ts	90	"C"	Yes	Yes	No
87625	ts	90	"C"	Yes	Yes	No
87626	ts	90	"C"	Yes	Yes	No
87641	ts	90	"C"	Yes	Yes	No
87642	ts	90	"C"	Yes	Yes	No
87643	ts	90	"C"	Yes	Yes	No
87644	ts	90	"C"	Yes	Yes	No
87660	ts	90	"C"	Yes	Yes	No
87661	ts	90	"C"	Yes	Yes	No
87662	ts	90	"C"	Yes	Yes	No
87663	ts	90	"C"	Yes	Yes	No
87679	ts	90	"C"	Yes	Yes	No
87680	ts	90	"C"	Yes	Yes	No
87681	ts	90	"C"	Yes	Yes	No
87682	ts	90	"C"	Yes	Yes	No
87698	ts	90	"C"	Yes	Yes	No
87699	ts	90	"C"	Yes	Yes	No
87700	ts	90	"C"	Yes	Yes	No
87701	ts	90	"C"	Yes	Yes	No
87718	ts	90	"C"	Yes	Yes	No
87719	ts	90	"C"	Yes	Yes	No
87720	ts	90	"C"	Yes	Yes	No
87721	ts	90	"C"	Yes	Yes	No
87736	ts	90	"C"	Yes	Yes	No
87737	ts	90	"C"	Yes	Yes	No
87738	ts	90	"C"	Yes	Yes	No
87739	ts	90	"C"	Yes	Yes	No

<u>Serial Number</u>	<u>Model</u>	<u>Year</u>	<u>Letter</u>	<u>Recall #147</u>	<u>Recall #148</u>	<u>Recall #149</u>
87755	ts	90	"C"	Yes	Yes	No
87756	ts	90	"C"	Yes	Yes	No
87767	ts	90	"C"	Yes	Yes	No
87774	ts	90	"C"	Yes	Yes	No
87775	ts	90	"C"	Yes	Yes	No
87776	ts	90	"C"	Yes	Yes	No
87793	ts	90	"C"	Yes	Yes	No
87794	ts	90	"C"	Yes	Yes	No
87795	ts	90	"C"	Yes	Yes	No
87812	tb	90	"C"	Yes	Yes	No
87813	ts	90	"C"	Yes	Yes	No
87814	ts	90	"C"	Yes	Yes	No
87815	ts	90	"C"	Yes	Yes	No
87831	ts	90	"C"	Yes	Yes	No
87832	ts	90	"C"	Yes	Yes	No
87833	ts	90	"C"	Yes	Yes	No
87834	ts	90	"C"	Yes	Yes	No
87876	ts	90	"C"	Yes	Yes	No
87877	ts	90	"C"	Yes	Yes	No
87878	ts	90	"C"	Yes	Yes	No
87879	ts	90	"C"	Yes	Yes	No
87880	ts	90	"C"	Yes	Yes	No
87888	tb	90	"C"	Yes	Yes	No
87966	tb	90	"D"	No	Yes	No
88050	tb	90	"D"	No	Yes	No
88177	tb	90	"D"	No	Yes	No
1990 vehicles affected:				377	373	48

1991 348 ts / tb

<u>Serial Number</u>	<u>Model</u>	<u>Year</u>	<u>Letter</u>	<u>Recall #147</u>	<u>Recall #148</u>	<u>Recall #149</u>
87895	ts	91	"D"	No	Yes	No
87897	ts	91	"D"	No	Yes	No
87898	ts	91	"D"	No	Yes	No

1990 Testarossa

<u>Serial Number</u>	<u>Model</u>	<u>Year</u>	<u>Letter</u>	<u>Recall #148</u>	<u>Serial Number</u>	<u>Model</u>	<u>Year</u>	<u>Letter</u>	<u>Recall #148</u>
85658	512	90	"E"	Yes	86206	512	90	"E"	Yes
85659	512	90	"E"	No	86207	512	90	"E"	Yes
85661	512	90	"E"	No	86222	512	90	"E"	Yes
85678	512	90	"E"	Yes	86224	512	90	"E"	Yes
85679	512	90	"E"	Yes	86227	512	90	"E"	Yes
85680	512	90	"E"	Yes	86242	512	90	"E"	Yes
85698	512	90	"E"	Yes	86244	512	90	"E"	Yes
85699	512	90	"E"	Yes	86261	512	90	"E"	Yes
85717	512	90	"E"	Yes	86265	512	90	"E"	Yes
85721	612	90	"E"	Yes	86300	512	90	"E"	Yes
85737	512	90	"E"	Yes	86318	612	90	"E"	Yes
85774	512	90	"E"	Yes	86322	512	90	"E"	Yes
85777	512	90	"E"	Yes	86335	512	90	"E"	Yes
85795	512	90	"E"	Yes	86354	512	90	"E"	Yes
85796	512	90	"E"	Yes	86508	512	90	"E"	Yes
85799	512	90	"E"	Yes	86509	512	90	"E"	Yes
85816	512	90	"E"	Yes	86766	512	90	"E"	Yes
85819	512	90	"E"	Yes	86767	512	90	"E"	Yes
85836	512	90	"E"	Yes	86863	512	90	"E"	Yes
85837	512	90	"E"	Yes	86864	512	90	"E"	Yes
85862	512	90	"E"	No	86865	512	90	"E"	Yes
85863	512	90	"E"	No	86957	512	90	"E"	Yes
85881	512	90	"E"	No	86960	512	90	"E"	Yes
85884	512	90	"E"	No	86975	512	90	"E"	Yes
85901	512	90	"E"	No	86977	512	90	"E"	Yes
85923	512	90	"E"	No	86995	512	90	"E"	Yes
85938	512	90	"E"	No	86997	512	90	"E"	Yes
85941	512	90	"E"	No	87012	512	90	"E"	Yes
85942	512	90	"E"	No	87013	512	90	"E"	Yes
85955	512	90	"E"	No	87014	512	90	"E"	Yes
85976	512	90	"E"	No	87096	512	90	"E"	Yes
85978	512	90	"E"	No	87097	512	90	"E"	Yes
85997	512	90	"E"	No	87098	512	90	"E"	Yes
85998	512	90	"E"	No	87099	512	90	"E"	Yes
86018	512	90	"E"	No	87100	512	90	"E"	Yes
86031	512	90	"E"	No	87113	512	90	"E"	Yes
86032	512	90	"E"	No	87114	512	90	"E"	Yes
86051	512	90	"E"	No	87115	512	90	"E"	Yes
86053	512	90	"E"	No	87116	512	90	"E"	Yes
86070	512	90	"E"	No	87117	512	90	"E"	Yes
86089	512	90	"E"	Yes	87118	512	90	"E"	Yes
86090	512	90	"E"	No	87132	512	90	"E"	Yes
86092	512	90	"E"	No	87134	512	90	"E"	Yes
86093	512	90	"E"	No	87135	512	90	"E"	Yes
86111	512	90	"E"	No	87136	512	90	"E"	Yes
86165	512	90	"E"	No	87137	512	90	"E"	Yes
86166	512	90	"E"	No	87138	512	90	"E"	Yes
86170	512	90	"E"	No	87140	512	90	"E"	Yes
86180	512	90	"E"	No	87231	512	90	"E"	Yes
86183	512	90	"E"	No	87232	512	90	"E"	Yes
86184	512	90	"E"	No					
86186	512	90	"E"	No					
86202	512	90	"E"	Yes					
86204	512	90	"E"	Yes					
86235	512	90	"E"	Yes					

1991 Testarossa

<u>Serial Number</u>	<u>Model</u>	<u>Year</u>	<u>Letter</u>	<u>Recall #148</u>	<u>Serial Number</u>	<u>Model</u>	<u>Year</u>	<u>Letter</u>	<u>Recall #148</u>
87233	512	90	"E"	Yes	86355	512	91	"E"	Yes
87234	512	90	"E"	Yes	86356	512	91	"E"	Yes
87235	512	90	"E"	Yes	86372	512	91	"E"	Yes
87236	512	90	"E"	Yes	86374	512	91	"E"	Yes
87250	512	90	"E"	Yes	86376	512	91	"E"	Yes
87251	512	90	"E"	Yes	86397	512	91	"E"	Yes
87252	512	90	"E"	Yes	86411	512	91	"E"	Yes
87253	512	90	"E"	Yes	86414	512	91	"E"	Yes
87254	512	90	"E"	Yes	86416	512	91	"E"	Yes
87255	512	90	"E"	Yes	86432	512	91	"E"	Yes
87269	512	90	"E"	Yes	86436	512	91	"E"	Yes
87270	512	90	"E"	Yes	86437	512	91	"E"	Yes
87271	512	90	"E"	Yes	86452	512	91	"E"	Yes
87272	512	90	"E"	Yes	86453	512	91	"E"	Yes
87273	512	90	"E"	Yes	86454	512	91	"E"	Yes
87274	512	90	"E"	Yes	86455	512	91	"E"	Yes
87289	512	90	"E"	Yes	86456	512	91	"E"	Yes
87290	512	90	"E"	Yes	86457	512	91	"E"	Yes
87291	512	90	"E"	Yes	86458	512	91	"E"	Yes
87292	512	90	"E"	Yes	86471	512	91	"E"	Yes
87293	512	90	"E"	Yes	86472	512	91	"E"	Yes
87368	512	90	"E"	Yes	86473	512	91	"E"	Yes
					86474	512	91	"E"	Yes
					86490	512	91	"E"	Yes
					86491	512	91	"E"	Yes
					86492	512	91	"E"	Yes
					86493	512	91	"E"	Yes
					86494	512	91	"E"	Yes
					86495	512	91	"E"	Yes
					86737	512	91	"E"	Yes
					86738	512	91	"E"	Yes
					86739	512	91	"E"	Yes
					86740	512	91	"E"	Yes
					86741	512	91	"E"	Yes
					86742	512	91	"E"	Yes
					86747	512	91	"E"	Yes
					86748	512	91	"E"	Yes
					86749	512	91	"E"	Yes
					86750	512	91	"E"	Yes
					86751	512	91	"E"	Yes
					86752	512	91	"E"	Yes
					86755	512	91	"E"	Yes
					86756	512	91	"E"	Yes
					86757	512	91	"E"	Yes
					86758	512	91	"E"	Yes
					86759	512	91	"E"	Yes
					86760	512	91	"E"	Yes
					86764	512	91	"E"	Yes

1990 Vehicles

Affected: 94

<u>Serial Number</u>	<u>Model</u>	<u>Year</u>	<u>Letter</u>	<u>Recall #148</u>	<u>Serial Number</u>	<u>Model</u>	<u>Year</u>	<u>Letter</u>	<u>Recall #148</u>
86765	512	91	"E"	Yes	87403	512	91	"E"	Yes
86824	512	91	"E"	Yes	87404	512	91	"E"	Yes
86825	512	91	"E"	Yes	87405	512	91	"E"	Yes
86826	512	91	"E"	Yes	87406	512	91	"E"	Yes
86827	512	91	"E"	Yes	87407	512	91	"E"	Yes
86830	512	91	"E"	Yes	87408	512	91	"E"	No
86831	512	91	"E"	Yes	87409	512	91	"E"	Yes
86832	512	91	"E"	Yes	87410	512	91	"E"	No
86833	512	91	"E"	Yes	87423	512	91	"E"	Yes
86834	512	91	"E"	Yes	87424	512	91	"E"	Yes
86835	512	91	"E"	Yes	87425	512	91	"E"	Yes
86836	512	91	"E"	Yes	87426	512	91	"E"	Yes
86841	512	91	"E"	Yes	87427	512	91	"E"	No
86842	512	91	"E"	Yes	87481	512	91	"E"	Yes
86843	512	91	"E"	Yes	87482	512	91	"E"	No
86844	512	91	"E"	Yes	87483	512	91	"E"	Yes
86845	512	91	"E"	Yes					
86846	512	91	"E"	Yes					
86860	512	91	"E"	Yes	1991 Vehicles				
86861	512	91	"E"	Yes	Affected:	108			
86862	512	91	"E"	Yes					
86955	512	91	"E"	Yes					
86956	512	91	"E"	Yes					
86958	512	91	"E"	Yes					
86959	512	91	"E"	Yes					
86974	512	91	"E"	Yes					
86976	512	91	"E"	Yes					
86978	512	91	"E"	Yes					
86979	512	91	"E"	Yes					
86993	512	91	"E"	Yes					
86994	512	91	"E"	Yes					
86996	512	91	"E"	Yes					
86998	512	91	"E"	Yes					
87015	512	91	"E"	Yes					
87095	512	91	"E"	Yes					
87131	512	91	"E"	Yes					
87133	512	91	"E"	Yes					
87139	512	91	"E"	Yes					
87294	512	91	"E"	Yes					
87369	512	91	"E"	Yes					
87370	512	91	"E"	Yes					
87371	512	91	"E"	Yes					
87383	512	91	"E"	Yes					
87384	512	91	"E"	Yes					
87385	512	91	"E"	Yes					
87386	512	91	"E"	Yes					
87387	512	91	"E"	No					
87388	512	91	"E"	Yes					
87402	512	91	"E"	Yes					

1989 Mondial t

<u>Serial Number</u>	<u>Model</u>	<u>Year</u>	<u>Letter</u>	<u>Recall #147</u>	<u>Recall #149</u>
81342	cpe	89	"F"	Yes	No
81374	cab	89	"F"	Yes	No
81380	cab	89	"F"	Yes	No
81390	cab	89	"F"	Yes	No
81396	cab	89	"F"	Yes	No
81481	cab	89	"F"	Yes	No
81487	cab	89	"F"	Yes	No
81498	cpe	89	"F"	Yes	No
81504	cpe	89	"F"	Yes	No
81514	cpe	89	"F"	Yes	No
81515	cab	89	"F"	Yes	No
81520	cpe	89	"F"	Yes	No
81534	cab	89	"F"	Yes	No
81545	cab	89	"F"	Yes	No
81551	cab	89	"F"	Yes	No
81563	cab	89	"F"	Yes	No
81575	cpe	89	"F"	Yes	No
81598	cab	89	"F"	Yes	No
81598	cab	89	"F"	Yes	No
81605	cpe	89	"F"	Yes	No
81611	cab	89	"F"	Yes	No
81629	cab	89	"F"	Yes	No
81661	cab	89	"F"	Yes	No
81757	cab	89	"F"	Yes	No
81774	cab	89	"F"	Yes	No
81791	cpe	89	"F"	Yes	No
81801	cpe	89	"F"	Yes	No
81802	cpe	89	"F"	Yes	No
81809	cab	89	"F"	Yes	No
81815	cpe	89	"F"	Yes	No
81820	cpe	89	"F"	Yes	No
81821	cpe	89	"F"	Yes	No
81822	cpe	89	"F"	Yes	No
81834	cpe	89	"F"	Yes	No
81835	cpe	89	"F"	Yes	No
81844	cab	89	"F"	Yes	No
81850	cab	89	"F"	Yes	No
81881	cpe	89	"F"	Yes	No
81882	cpe	89	"F"	Yes	No
81883	cab	89	"F"	Yes	No
81885	cab	89	"F"	Yes	No
81896	cab	89	"F"	Yes	No
81899	cab	89	"F"	Yes	No
81900	cab	89	"F"	Yes	No
81901	cab	89	"F"	Yes	No
81902	cab	89	"F"	Yes	No
81909	cab	89	"F"	Yes	No
81914	cab	89	"F"	Yes	No
81916	cpe	89	"F"	Yes	No
81917	cab	89	"F"	Yes	No
81920	cab	89	"F"	Yes	No
81923	cab	89	"F"	Yes	No
81936	cab	89	"F"	Yes	No

<u>Serial Number</u>	<u>Model</u>	<u>Year</u>	<u>Letter</u>	<u>Recall #147</u>	<u>Recall #148</u>
81939	cab	89	"F"	Yes	No
81943	cab	89	"F"	Yes	No
81947	cab	89	"F"	Yes	No
81955	cab	89	"F"	Yes	No
81958	cab	89	"F"	Yes	No
81959	cab	89	"F"	Yes	No
81963	cab	89	"F"	Yes	No
81964	cab	89	"F"	Yes	No
81968	cab	89	"F"	Yes	No
81970	cab	89	"F"	Yes	No
81973	cab	89	"F"	Yes	No
81974	cpe	89	"F"	Yes	No
81975	cab	89	"F"	Yes	No
81976	cab	89	"F"	Yes	No
81980	cpe	89	"F"	Yes	No
81984	cab	89	"F"	Yes	No
81987	cab	89	"F"	Yes	No
81990	cab	89	"F"	Yes	No
81991	cab	89	"F"	Yes	No
81993	cab	89	"F"	Yes	No
81998	cab	89	"F"	Yes	No
82012	cab	89	"F"	Yes	No
82018	cpe	89	"F"	Yes	No
82019	cab	89	"F"	Yes	No
82022	cab	89	"F"	Yes	No
82032	cab	89	"F"	Yes	No
82035	cab	89	"F"	Yes	No
82040	cab	89	"F"	Yes	No
82043	cab	89	"F"	Yes	No
82052	cab	89	"F"	Yes	No
82056	cab	89	"F"	Yes	No
82059	cpe	89	"F"	Yes	No
82061	cab	89	"F"	Yes	No
82070	cab	89	"F"	Yes	No
82073	cab	89	"F"	Yes	No
82077	cab	89	"F"	Yes	No
82083	cab	89	"F"	Yes	No
82090	cab	89	"F"	Yes	No
82093	cab	89	"F"	Yes	No
82097	cpe	89	"F"	Yes	No
82100	cab	89	"F"	Yes	No
82111	cab	89	"F"	Yes	No
82114	cab	89	"F"	Yes	No
82118	cab	89	"F"	Yes	No
82121	cab	89	"F"	Yes	No
82131	cab	89	"F"	Yes	No
82134	cab	89	"F"	Yes	No
82136	cpe	89	"F"	Yes	No
82139	cab	89	"F"	Yes	No
82142	cab	89	"F"	Yes	No
82154	cab	89	"F"	Yes	No
82156	cpe	89	"F"	Yes	No

<u>Serial Number</u>	<u>Model</u>	<u>Year</u>	<u>Letter</u>	<u>Recall #147</u>	<u>Recall #149</u>
82159	cab	89	"F"	Yes	No
82162	cab	89	"F"	Yes	No
82165	cab	89	"F"	Yes	No
82172	cab	89	"F"	Yes	No
82176	cab	89	"F"	Yes	No
82182	cab	89	"F"	Yes	No
82195	cab	89	"F"	Yes	No
82198	cab	89	"F"	Yes	No
82200	cpe	89	"F"	Yes	No
82203	cab	89	"F"	Yes	No
82215	cab	89	"F"	Yes	No
82218	cab	89	"F"	Yes	No
82222	cab	89	"F"	Yes	No
82226	cab	89	"F"	Yes	No
82235	cab	89	"F"	Yes	No
82238	cab	89	"F"	Yes	No
82242	cpe	89	"F"	Yes	No
82246	cab	89	"F"	Yes	No
82255	cab	89	"F"	Yes	No
82257	cab	89	"F"	Yes	No
82262	cab	89	"F"	Yes	No
82266	cab	89	"F"	Yes	No
82275	cab	89	"F"	Yes	No
82279	cab	89	"F"	Yes	No
82283	cab	89	"F"	Yes	No
82287	cpe	89	"F"	Yes	No
82295	cab	89	"F"	Yes	No
82299	cab	89	"F"	Yes	No
82303	cab	89	"F"	Yes	No
82307	cab	89	"F"	Yes	No
82315	cab	89	"F"	Yes	No
82319	cpe	89	"F"	Yes	No
82323	cab	89	"F"	Yes	No
82327	cab	89	"F"	Yes	No
82334	cab	89	"F"	Yes	No
82338	cab	89	"F"	Yes	No
82341	cab	89	"F"	Yes	No
82344	cab	89	"F"	Yes	No
82348	cab	89	"F"	Yes	No
82351	cpe	89	"F"	Yes	No
82354	cab	89	"F"	Yes	No
82357	cab	89	"F"	Yes	No
82364	cab	89	"F"	Yes	No
82367	cab	89	"F"	Yes	No
82370	cab	89	"F"	Yes	No
82373	cab	89	"F"	Yes	No
82378	cab	89	"F"	Yes	No
82381	cpe	89	"F"	Yes	No
82384	cab	89	"F"	Yes	No
82388	cab	89	"F"	Yes	No
82394	cab	89	"F"	Yes	No
82397	cab	89	"F"	Yes	No

<u>Serial Number</u>	<u>Model</u>	<u>Year</u>	<u>Letter</u>	<u>Recall #137</u>	<u>Recall #146</u>
82401	cab	89	"F"	Yes	No
82405	cab	89	"F"	Yes	No
82408	cab	89	"F"	Yes	No
82412	cab	89	"F"	Yes	No
82416	cpe	89	"F"	Yes	No
82420	cab	89	"F"	Yes	No
82424	cab	89	"F"	Yes	No
82428	cab	89	"F"	Yes	No
82431	cab	89	"F"	Yes	No
82434	cab	89	"F"	Yes	No
82438	cab	89	"F"	Yes	No
82442	cab	89	"F"	Yes	No
82445	cpe	89	"F"	Yes	No
82447	cab	89	"F"	Yes	No
82451	cab	89	"F"	Yes	No
82455	cab	89	"F"	Yes	No
82458	cab	89	"F"	Yes	No
82462	cab	89	"F"	Yes	No
82466	cab	89	"F"	Yes	No
82472	cab	89	"F"	Yes	No
82475	cpe	89	"F"	Yes	No
82479	cab	89	"F"	Yes	No
82483	cab	89	"F"	Yes	No
82490	cab	89	"F"	Yes	No
82494	cab	89	"F"	Yes	No
82498	cab	89	"F"	Yes	No
82502	cab	89	"F"	Yes	No
82508	cab	89	"F"	Yes	No
82511	cab	89	"F"	Yes	No
82515	cpe	89	"F"	Yes	No
82519	cab	89	"F"	Yes	No
82523	cab	89	"F"	Yes	No
82527	cab	89	"F"	Yes	No
82530	cab	89	"F"	Yes	No
82533	cab	89	"F"	Yes	No
82539	cab	89	"F"	Yes	No
82543	cab	89	"F"	Yes	No
82547	cpe	89	"F"	Yes	No
82550	cab	89	"F"	Yes	No
82553	cpe	89	"F"	Yes	No
82559	cab	89	"F"	Yes	No
82563	cab	89	"F"	Yes	No
82567	cab	89	"F"	Yes	No
82571	cab	89	"F"	Yes	No
82574	cpe	89	"F"	Yes	No
82580	cpe	89	"F"	Yes	No
82583	cpe	89	"F"	Yes	No
82587	cpe	89	"F"	Yes	No

1989 Vehicles

Affected:	Cabriolet	166	<u>TOTAL</u>
	Coupe	42	208

1990 Mondial t

<u>Serial Number</u>	<u>Model</u>	<u>Year</u>	<u>Letter</u>	<u>Recall #147</u>	<u>Recall #148</u>
84665	cab	90	"F"	Yes	no
85307	cab	90	"F"	Yes	no
85380	cab	90	"F"	Yes	no
85439	cab	90	"F"	Yes	no
85507	cab	90	"F"	Yes	no
85558	cab	90	"F"	Yes	no
85573	cab	90	"F"	Yes	no
85615	cab	90	"F"	Yes	no
85674	cab	90	"F"	Yes	no
85714	cab	90	"F"	Yes	no
85771	cab	90	"F"	Yes	no
85831	cab	90	"F"	Yes	no
85868	cab	90	"F"	Yes	no
85927	cab	90	"G"	Yes	Yes
85966	cab	90	"G"	Yes	Yes
86079	cab	90	"G"	Yes	Yes
86115	cab	90	"G"	Yes	Yes
86152	cab	90	"G"	Yes	Yes
86190	cab	90	"G"	Yes	Yes
86247	cab	90	"G"	Yes	Yes
86306	cab	90	"G"	Yes	Yes
86364	cab	90	"G"	Yes	Yes
86423	cab	90	"G"	Yes	Yes
86441	cab	90	"G"	Yes	Yes
86463	cab	90	"G"	Yes	Yes
86480	cab	90	"G"	Yes	Yes
86500	cab	90	"G"	Yes	Yes
86520	cab	90	"G"	Yes	Yes
86551	cab	90	"G"	Yes	Yes
86570	cab	90	"G"	Yes	Yes
86593	cab	90	"G"	Yes	Yes
86628	cab	90	"G"	Yes	Yes
86647	cab	90	"G"	Yes	Yes
86666	cab	90	"G"	Yes	Yes
86667	cab	90	"G"	Yes	Yes
86688	cab	90	"G"	Yes	Yes
86704	cab	90	"G"	Yes	Yes
86716	cab	90	"G"	Yes	Yes
86734	cab	90	"G"	Yes	Yes
86753	cab	90	"G"	Yes	Yes
86771	cab	90	"G"	Yes	Yes
86791	cab	90	"G"	Yes	Yes
86810	cab	90	"G"	Yes	Yes
86829	cab	90	"G"	Yes	Yes
86848	cab	90	"G"	Yes	Yes
86866	cab	90	"G"	Yes	Yes
86894	cab	90	"G"	Yes	Yes
86914	cab	90	"G"	Yes	Yes
86934	cab	90	"G"	Yes	Yes
86950	cab	90	"G"	Yes	Yes

<u>Serial Number</u>	<u>Model</u>	<u>Year</u>	<u>Letter</u>	<u>Recall #147</u>	<u>Recall #148</u>
86951	cab	90	"G"	Yes	Yes
86971	cab	90	"G"	Yes	Yes
86990	cab	90	"G"	Yes	Yes
87009	cab	90	"G"	Yes	Yes
87010	cab	90	"G"	Yes	Yes
87027	cab	90	"G"	Yes	Yes
87028	cab	90	"G"	Yes	Yes
87029	cab	90	"G"	Yes	Yes
87047	cab	90	"G"	Yes	Yes
87065	cab	90	"G"	Yes	Yes
87084	cab	90	"G"	Yes	Yes
87102	cab	90	"G"	Yes	Yes
87121	cab	90	"G"	Yes	Yes
87142	cab	90	"G"	Yes	Yes
87160	cab	90	"G"	Yes	Yes
87198	cab	90	"G"	Yes	Yes
87218	cab	90	"G"	Yes	Yes
87238	cab	90	"G"	Yes	Yes
87257	cab	90	"G"	Yes	Yes
87276	cab	90	"G"	Yes	Yes
87295	cab	90	"G"	Yes	Yes
87352	cab	90	"G"	Yes	Yes
87309	cab	90	"C"	Yes	Yes
87429	cab	90	"G"	Yes	Yes
87446	cab	90	"G"	Yes	Yes
87467	cab	90	"G"	Yes	Yes
87486	cab	90	"G"	Yes	Yes
87505	cab	90	"G"	Yes	Yes
87524	cab	90	"G"	Yes	Yes
87543	cab	90	"G"	Yes	Yes
87562	cab	90	"G"	Yes	Yes
87728	cab	90	"G"	Yes	Yes
87746	cab	90	"G"	Yes	Yes
87747	cab	90	"G"	Yes	Yes
87761	cab	90	"G"	Yes	Yes
87782	cab	90	"G"	Yes	Yes
87802	cab	90	"G"	Yes	Yes
87819	cab	90	"G"	Yes	Yes
87838	cab	90	"G"	Yes	Yes
87855	cab	90	"G"	Yes	Yes
87872	cab	90	"G"	Yes	Yes
87893	cab	90	"G"	Yes	Yes
87908	cab	90	"G"	Yes	Yes
87930	cab	90	None	No	No
87949	cab	90	None	No	No
87970	cab	90	None	No	No
87991	cab	90	None	No	No
88008	cab	90	None	No	No

1990 Vehicles

Affected:

93

90

P 040 532 500



**Receipt for
Certified Mail**

No Insurance Coverage Provided
Do not use for International Mail
(See Reverse)

Sender	
K. McCay	
Recipient No.	
Ferrari	
P.O. Number ZIP Code	
Weight	\$
Permit No.	
Special Delivery fee	
Postnet Delivery fee	
Return Receipt showing to Whom & Date Delivered	
Return Receipt showing to Whom Date and Addressee's Address	
TOTAL Postage & Fees	\$
Postmark or Date	
92V-071 PAW	

PS Form 3800, June 1991

ADDITIONAL INFORMATION REQUIRED

In order for us to complete our file on this matter, please provide the following additional information:

Under Part 573.5(c)(8), we request that Ferrari identify and describe how the remedial program will be conducted. It is otherwise assumed that this recall shall begin nationally, and uniformly, within 30 calendar days. We request that Ferrari provide a proposed schedule for the implementation of this recall. The schedule should include, but not be limited to, the date the manufacturer press release to the media will be published, the date(s) of notification to distributors and dealers/retailers, and the date(s) of notification to purchasers. Identify the date on which parts necessary for remedy of this recall will be available. The schedule must also include an explanation for any delay in the implementation of this recall.

Please provide this information, referencing the National Highway Traffic Safety Administration identification codes, to this office **by July 2, 1992**. A copy of a Defect/Noncompliance Information Report guide is enclosed to assist in providing this information in the future.

Ferrari is responsible for the remedy of these vehicles from this date forward, regardless of vehicle age, mileage, or ownership.

You should know that the agency provides a listing of safety recalls to the media at the end of each month. This recall will be a part of that listing.

NOTIFICATION TO PURCHASERS

This office reviews all documents concerning a safety recall campaign. The notification letter to purchasers of all recalled vehicles or items of motor vehicle equipment is required by Section 153 of the Act and Part 577.

Part 577.5(c) requires that the manufacturer who has determined a **safety defect/noncompliance exists** in his vehicles or items of equipment must state that the defect or noncompliance does exist in his vehicles or items of vehicle equipment specifically using one of the two sentences provided in Part 577.5(c) as appropriate. You **cannot state that the defect or noncompliance "may" exist** (or use any other similar word such as could, might, can, etc.). The word "**may**" implies that the defect **may not exist** on any of the vehicles and is considered to be a disclaimer specifically prohibited by Part 577.8(a). Stating that the safety defect exists in certain vehicles or items of equipment as discussed in Part 577.5(d) is permissible.

Telephone Numbers for the Auto Safety Hotline:

The telephone number for the Auto Safety Hotline must be given as required by Part 577.5(g)(1)(vii). However, the correct telephone numbers for the Hotline are: (800) 424-9393 nationally, and (202) 366-0123 for Washington, DC area residents. These numbers are to be used in the notification for this recall and any future safety recall notification.

QUARTERLY STATUS REPORTS

The first quarterly status report for this campaign, as required in Part 573.6, is required to be submitted within 25 working days after the close of the calendar quarter in which notification to purchasers begins. For instance, the current calendar quarter ends on June 30, 1992, and the first quarterly report for recalls where owner notification begins in this quarter is due by August 4, 1992. A Quarterly Report Guide is enclosed to assist in providing the information.

For the first quarterly report, we request that Ferrari identify the number of vehicles which were returned or otherwise remedied prior to sale to owners.

Quarterly reports are due for the first 6 consecutive quarters once owner notification has begun. In the case where the recall appears to be completed, quarterly reporting is required until your company is notified otherwise by this office. Each report is due within 25 working days after the close of the respective quarter.

Sincerely,



James P. Talentino, Chief
Defect Identification Division
Office of Defects Investigation
Enforcement

Enclosures:
Defect/Noncompliance Information Report Guide
Quarterly Report Guide

NHTSA:NEF:ODI
PWALLACE:kjs:6-2-92
Assign to: Powertrain:cc: NEF-01, NEF-10, NEF-11:JPTalentino
NEF-111 Subj/Working/Chron File--Document #L:\patw\92v071.ack

Ferrari

Ferrari North America, Inc.
250 Sylvan Avenue
Englewood Cliffs, NJ 07632
201-816-2600
TLX: 248021
FAX: 201-816-2626

RECEIVED
MAY 12 1992
GENERAL SERVICE
SALES & SERVICE DIVISION

May 11, 1992

92V-071 (U)

Mr. Charles L. Gauthier, Director
Office of Defects Investigation
National Highway Traffic Safety Administration
Washington, D.C. 20590

Dear Director:

Please find herewith enclosed Vehicle Safety Defect Initial Information Reports with respect to three Recall Campaigns which we are initiating in order to correct the following.

- 1) On vehicles with Vehicle Identification Number lower than 88386, the aluminum fuel line fittings on certain fuel Injection lines may corrode under extreme environmental conditions. Should such condition remain unnoticed, the result could be breakage of the aluminum fuel line fitting resulting in fuel leakage. As with any type of fuel system leakage, the possibility of a vehicle engine fire may exist.

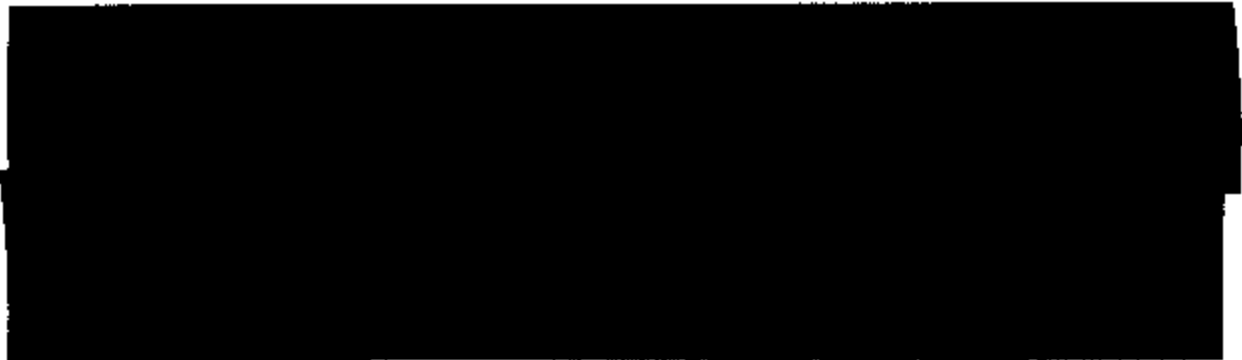

The corrective action will require approximately 1.5 hours.

For the above campaign, it is our intention to notify the Ferrari Dealers with a comprehensive letter explaining the remedy; furthermore it is our intention to notify each vehicle owner with a single letter mentioning the recall modification required.

Draft copies of the letters that Ferrari North America, Inc. will send to the owners and to the Ferrari Dealers along with the technical instructions will be submitted to your office by may 15, 1992.

Yours truly,

Kenneth W. McCay
Technical Director
Ferrari North America, Inc.

Enclosure

FERRARI NORTH AMERICA, INC.
250 SYLVAN AVENUE
ENGLEWOOD CLIFFS, N.J. 07632

**VEHICLE SAFETY DEFECT
INITIAL INFORMATION REPORT**

**348 ts/tb & Mondial t - Fuel Injection lines
Recall No. 147**

A) DESCRIPTION OF DEFECT:

On vehicles with Vehicle Identification Number lower than 883866, the aluminum fuel line fittings on certain fuel Injection lines may corrode under extreme environmental conditions. Should such condition remain unnoticed, the result could be breakage of the aluminum fuel line fitting resulting in fuel leakage.

B) CHRONOLOGY OF EVENTS WHICH LED TO DETERMINATION OF A SAFETY DEFECT:

As a result of extended durability testing, Ferrari S.p.A. discovered that the aluminum fittings on certain fuel injection lines may corrode if exposed extreme environmental conditions.

C) MEASURES TO BE TAKEN TO REPAIR VEHICLE:

The remedy consists in the replacement of the four fuel injection lines with modified fuel lines which are now constructed with a corrosion resistant coating to prevent fuel line surface corrosion. The operation is free-of-charge for the vehicle owner, and will require approximately .80 hours for 348 ts/tb and 1.2 hours for Mondial t coupe and cabriolet.

ESTIMATED INITIATION OF CORRECTIVE ACTION: JUNE 1992

92V-071 (02)

**VEHICLE SAFETY DEFECT
INITIAL INFORMATION REPORT**

Fuel injection lines

Recall No. 147

Date submitted: May 14, 1992
 Date received: May 11, 1992
 Campaign No.: 147
 Campaign Date: June 1992

ENCLOSED MFG. DATES

MAKE	MODEL	MODEL YEAR	NO. OF VEHICLES	FROM	THROUGH	OTHER VEHICLE IDENTIFICATION
FERRARI	348 TS / TB	1989	134	JULY 1989	JAN. 1990	
FERRARI	MONDIAL T CPE / CAB	1989	208	MAY 1989	AUG. 1989	
FERRARI	348 TS / TB	1990	377	MAR. 1990	DEC. 1990	
FERRARI	MONDIAL T CAB	1990	93	FEB. 1990	DEC. 1990	

Ferrari

Ferrari North America, Inc.
250 Sylvan Avenue
Englewood Cliffs, NJ 07632
201-816-2600
TLX: 248021
FAX: 201-816-2626

RECEIVED
MAY 12 1992
OFFICE
DEFECT INVESTIGATION

May 11, 1992

92V-071 (01)

Mr. Charles L. Gauthier, Director
Office of Defects Investigation
National Highway Traffic Safety Administration
Washington, D.C. 20590

Dear Director:

Please find herewith enclosed Vehicle Safety Defect Initial Information Reports with respect to three Recall Campaigns which we are initiating in order to correct the following.

- 1) On vehicles with Vehicle Identification Number lower than 88386, the aluminum fuel line fittings on certain fuel injection lines may corrode under extreme environmental conditions. Should such condition remain unnoticed, the result could be breakage of the aluminum fuel line fitting resulting in fuel leakage. As with any type of fuel system leakage, the possibility of a vehicle engine fire may exist.

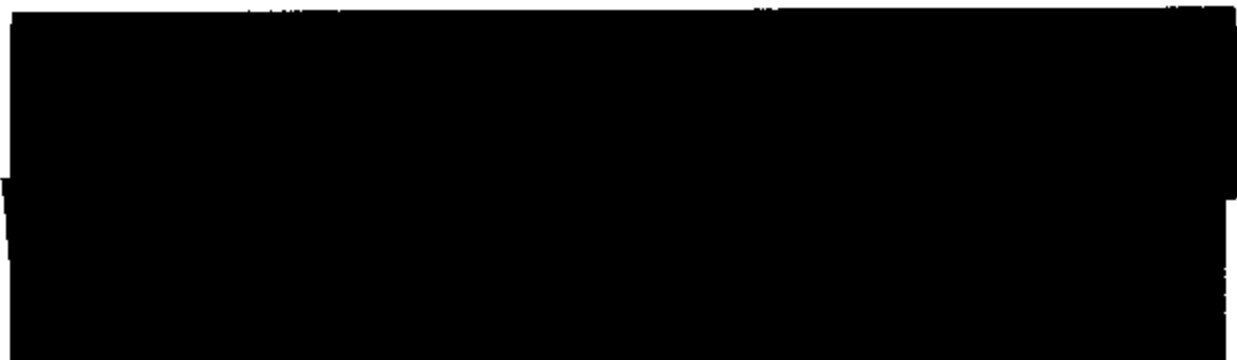

The corrective action will require approximately 1.5 hours.

For the above campaign, it is our intention to notify the Ferrari Dealers with a comprehensive letter explaining the remedy; furthermore it is our intention to notify each vehicle owner with a single letter mentioning the recall modification required.

Draft copies of the letters that Ferrari North America, Inc. will send to the owners and to the Ferrari Dealers along with the technical instructions will be submitted to your office by May 15, 1992.

Yours truly,

Kenneth W. McCay
Technical Director
Ferrari North America, Inc.



FERRARI NORTH AMERICA, INC.
250 SYLVAN AVENUE
ENGLEWOOD CLIFFS, N.J. 07632

**VEHICLE SAFETY DEFECT
INITIAL INFORMATION REPORT**

348 ts/tb & Mondial t - Fuel Injection Lines
Recall No. 147

A) DESCRIPTION OF DEFECT:

On vehicles with Vehicle Identification Number lower than 86386, the aluminum fuel line fittings on certain fuel injection lines may corrode under extreme environmental conditions. Should such condition remain unnoticed, the result could be breakage of the aluminum fuel line fitting resulting in fuel leakage.

B) CHRONOLOGY OF EVENTS WHICH LED TO DETERMINATION OF A SAFETY DEFECT:

As a result of extended durability testing, Ferrari S.p.A. discovered that the aluminum fittings on certain fuel injection lines may corrode if exposed extreme environmental conditions.

C) MEASURES TO BE TAKEN TO REPAIR VEHICLE:

The remedy consists in the replacement of the four fuel injection lines with modified fuel lines which are now constructed with a corrosion resistant coating to prevent fuel line surface corrosion. The operation is free-of-charge for the vehicle owner, and will require approximately .80 hours for 348 ts/tb and 1.2 hours for Mondial t coupe and cabriolet.

ESTIMATED INITIATION OF CORRECTIVE ACTION: JUNE 1992

92V-071 (02)

**VEHICLE SAFETY DEFECT
INITIAL INFORMATION REPORT**

Fuel injection lines

Recall No. 147

Date submitted: May 14, 1992
 Date received: May 11, 1992
 Campaign No. : 147
 Campaign Date: June 1992

ENCLOSED MFG. DATES

MAKE	MODEL	MODEL YEAR	NO. OF VEHICLES	FROM	THROUGH	OTHER VEHICLE IDENTIFICATION
FERRARI	348 TS / TB	1989	134	JULY 1989	JAN. 1990	
FERRARI	MONDIAL T CPE / CAB	1989	208	MAY 1989	AUG. 1989	
FERRARI	348 TS / TB	1990	377	MAR. 1990	DEC. 1990	
FERRARI	MONDIAL T CAB	1990	93	FEB. 1990	DEC. 1990	

Ferrari

Ferrari North America, Inc.
250 Sylvan Avenue
Englewood Cliffs, NJ 07632
201-816-2600
TLX: 248021
FAX: 201-816-2626

RECEIVED
MAY 21 1992
OFFICE
DEFECTS INVESTIGATION

May 15, 1992

Mr. William A. Bochly
Associate Administrator
National Highway Traffic Safety Administration
Washington, D.C. 20590

SUBJECT: Recall campaign no. 92V-071, 92V-072, and 92V-073

Dear Director:

We are, in receipt of your telefax of May 14, 1992, acknowledging receipt of Ferrari's initial defect notification. We are forwarding today to your attention under separate cover (Federal express), the following documents for your review regarding the above mentioned Recall campaign:

- Letter of notification for Ferrari Authorized Dealers.
- Letters to Ferrari Owners.
- Technical instructions for performing remedies.
- Administration instructions for Authorized dealer reimbursement.

The scheduled dates for implementation of the above recall campaigns are planned as follows:

- Availability of required spare parts - an initial supply of the required spare parts will be shipped the week of June 1, 1992 to each authorized dealer.
- Recall booklet for dealer which includes the letter to dealer, letter to vehicle owner, and Technical / Administrative procedures will be sent the week of June 1, 1992.
- Ferrari North America Technical managers will contact each Service department at all United States Ferrari authorized dealers, advising them of the recall campaign. This will be done the week of June 1, 1992.
- Letters to Ferrari owners will be mailed from Monday June 15, 1992 to June 30, 1992.

Please advise us of any changes or modifications you may find necessary after your review.

Yours truly,

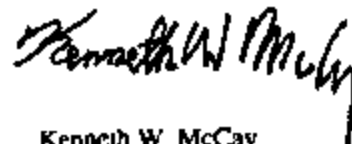

Kenneth W. McCay
Technical Director
Ferrari North America, Inc.



TECHNICAL

RECALL CAMPAIGN

**REF. NO. 147
FUEL INJECTION LINES**

**REF. NO. 148
UPPER STEERING COLUMN
LOCKNUT**

**REF. NO. 149
STEERING BOX EXTENSION
FASTENER**

JUNE 1992

READ, INITIAL
AND PASS ON »

Service Manager	Parts Manager	Service Writer	Technician				Warranty Clerk

TABLE OF CONTENTS

<u>TITLE</u>	<u>PAGE</u>
Letter to Ferrari Dealer	2 - 3
<u>Recall Ref. No. 147</u> 348 ts/tb - Mondial t cpe. / cab. Fuel injection lines	4 - 8
<u>Recall Ref. No. 148</u> 348 ts/tb, Mondial t cpe. / cab. & Testarossa Upper steering column locknut	10 - 11
<u>Recall Ref. No. 149 - 348 ts/tb</u> 348 ts/tb Steering box extension fastener	12 - 13
Recall Claim form Instructions	14 - 15
Letter to Customer	16 - 32
Vehicle Master List	32 - 45

Ferrari North America, Inc.
250 Sylvan Avenue
Englewood Cliffs, NJ 07532
201-816-2600
TLX: 248021
FAX: 201-816-2626

June 1992

Dear Ferrari Dealer:

Ferrari S.p.A., the manufacturer of Ferrari automobiles, has determined that certain defects may exist in particular 1989, 1990 and 1991 model year Ferrari vehicles.



- 1) On 348 ts/tb and Mondial t vehicles with Vehicle Identification Number lower than 88386, the aluminum fittings on certain *fuel injection lines* may corrode under extreme environmental conditions. Should such condition remain unnoticed, the result could be breakage of the aluminum fuel line fitting resulting in fuel leakage. As with any type of fuel system leakage, the possibility of a vehicle engine fire may exist.
- 2) On 348 ts/tb, Mondial t, and Testarossa vehicles with Vehicle Identification Number lower than 87898, the *upper steering column locknut* may have been manufactured with a lower class of material and self-locking properties. This may result in a loss of tightening torque on the upper steering column fastener. Should such condition remain unnoticed and the use of the car be prolonged for an extensive period of time, loosening of the fastener could occur resulting in play in the steering system and consequential impairment of handling.
- 3) On 348 ts/tb vehicles with Vehicle Identification Number lower than 86232, the *steering box extension fastener* may have been manufactured with a lower class of material and self-locking properties. This may result in a loss of tightening torque on the upper steering column fastener. Should such condition remain unnoticed and the use of the car be prolonged for an extensive period of time, loosening of the fastener could occur resulting in play in the steering system and consequential impairment of handling.

Instructions for performing the necessary remedies are herewith enclosed. The corrective action will require approximately 1.5 hours.

Accordingly, we have sent notices to all owners of the potentially affected vehicles advising them of these problems and requesting that they contact any authorized Ferrari dealer for the necessary repairs, as per the attached notification letter.

ConL.....

Upon receipt of the campaign notice properly signed by the customer and by you or your authorized representative, we will, of course, reimburse you for the labor and applicable parts expended in carrying out these campaigns.

Obviously, if you have any of the potentially affected vehicles in your stock, you must not sell them until you have performed the necessary repairs. If you have already sold any vehicles with the chassis number specified in the enclosed instructions and have not yet sent in the retail sales cards, please do so at once so we may notify these owners.



Thank you for your cooperation.
Very truly yours,

Kenneth McCay
Technical Director
Ferrari North America, Inc.

RECALL CAMPAIGN NO. 147

INTRODUCTION - Fuel injection lines

- SUBJECT:** Recall Campaign No. 147
Ferrari 348 ts/tb - Mondial t Models - Fuel injection lines
- VEHICLES:** All Ferrari 348 ts/tb and Mondial t Models with the following serial number ranges:
- Ferrari 348 ts/tb, Model Year 1989 and 1990, starting from serial number 82277 up to serial number 87888 included.
 - Ferrari Mondial t coupe and cabriolet, Model Year 1989 and 1990, starting from serial number 81342 up to serial number 87908 included.
- CONDITION:** The aluminum fuel line fittings on certain fuel Injection lines may corrode under extreme environmental conditions. Should such condition remain unnoticed, the result could be breakage of the aluminum fuel line fitting resulting in fuel leakage.
- REMEDY:** Replacement of the Fuel injection system lines "A & B" with the modified fuel lines (shown on Fig 1, page 6).
- PARTS:** Quantities required for each vehicle and identification of the new Fuel lines with the new part numbers, are shown on the Parts List Table "A" on Page 8). The new part fittings are now aluminum with a non-corrosive coating.
- COST:**
- a) An initial supply of new fuel lines will be shipped to your dealership. Your parts account will be charged accordingly. The Table on page 8 indicates the part numbers and quantity required per vehicle.
 - b) Additional fuel return lines can be ordered from the Ferrari North America Parts Department in Englewood Cliffs, New Jersey.
- LABOR:**
- | | |
|---------------|-----------------------|
| Operation No. | 147 |
| Time | 348 ts/tb - 0.8 hours |
| | Mondial t - 1.2 hours |

RECALL CAMPAIGN NO. 147

REIMBURSEMENT: On receipt of the correctly completed recall campaign claim (see Recall Claim form Instructions, page 14).

INSTRUCTIONS FOR FUEL LINE REPLACEMENT

A. Preliminary: The replacement Fuel lines (Fig.#1) are supplied as a spare parts by the part numbers on Table "A", Page 8.

B. Procedure for installation

WARNING: NO SMOKING

HIGHLY FLAMMABLE MATERIAL. KEEP AWAY FROM SPARKS OR OPEN FLAMES. PROVIDE ADEQUATE VENTILATION. FUEL, WHEN SATURATED ON CLOTHING, WILL CAUSE SKIN IRRITATION. PROCEED ACCORDINGLY.

NOTE: BE SURE TO UTILIZE PROPER EQUIPMENT FOR SAFE TRANSFER OF FUEL FROM CAR TO APPROVED FUEL CONTAINER.

DO NOT PERFORM THIS PROCEDURE ON A WARM ENGINE.

- 1) Disconnect battery (Main switch).
- 2) Cover rear fenders (also Trunk lid area) with fender covers.
- 3) Remove Fuel tank fill cap to release pressure from the fuel tank.
- 4) Place a catch pan under the fuel filter and loosen upper filter connection. While fuel is draining, loosen fuel line fitting at regulator end of the Fuel Injection rail. This will allow the remainder of fuel in rail to drain.
- 5) Remove both fuel lines "A & B" as shown in Fig.# 1 and replace with new lines.
- 6) Inspect 1/4 bank Fuel Injection return line for any damage due to contact with the timing cover. If damage is found the line must be replaced using the procedure "C - Procedure for replacement of fuel return line" found on page # 7 of this booklet. If no damage is found, please insure that the return line is secured on the clip found on the timing cover (Fig.#3). Also the Return Fuel line **must not** contact the Timing cover or A/C Compressor lines.
- 7) Repeat procedure #4 through #6 for 5/8 bank fuel lines.
- 8) Replace fuel tank filler cap.
- 9) Start engine, run for 30 seconds and then shut off. Check for leaks.

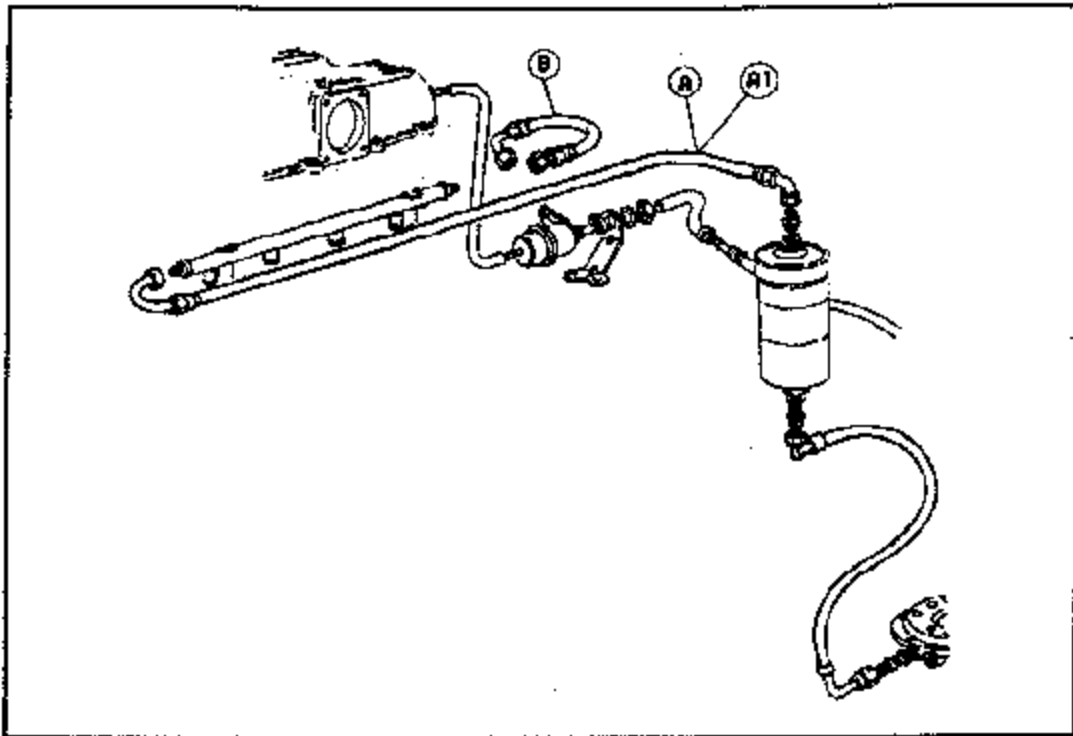

Fig.#1

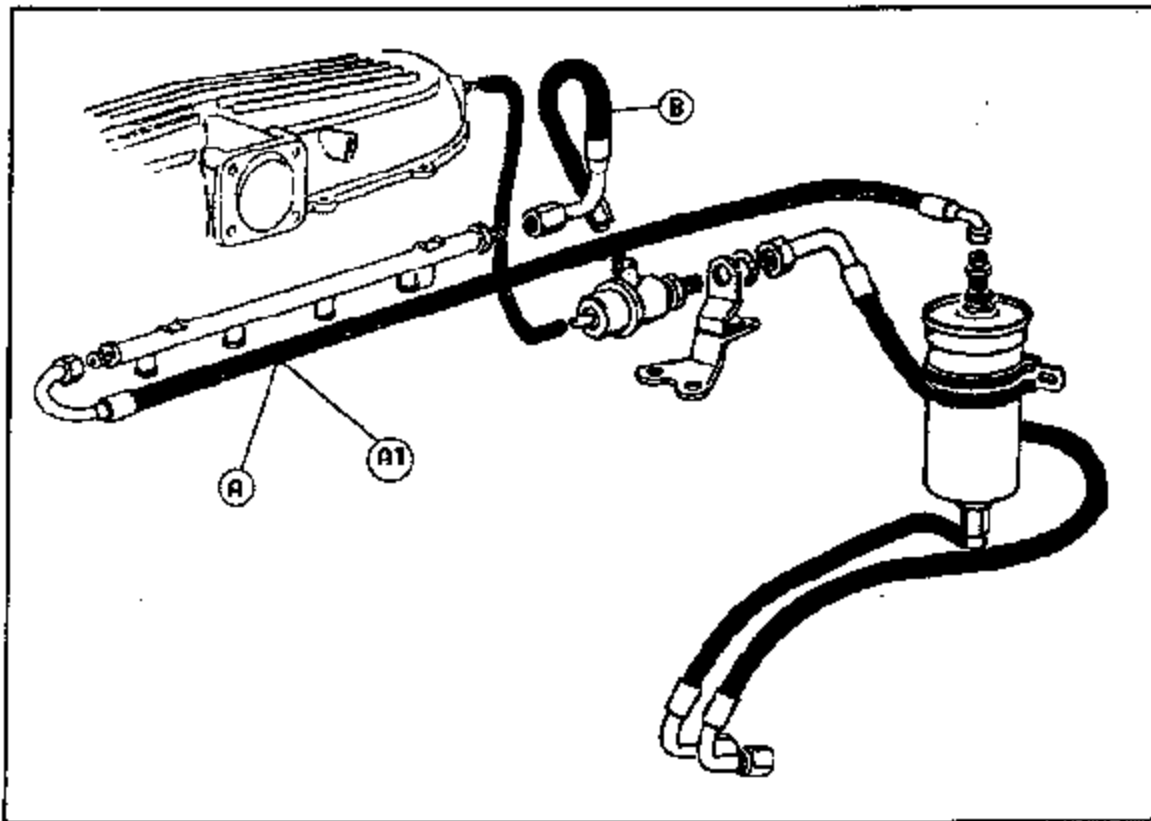

Fig.#2

Recall #147**TABLE "A" PARTS LIST**

VEHICLE	PART DESCRIPTION	PART NUMBER	QTY. NEEDED
MONDIAL T COUPE	Sx Fuel line (filter to fuel rail)	143789	1
	Dx Fuel line (filter to fuel rail)	143788	1
	Fuel line (fuel rail to pressure regulator)	149812	2
MONDIAL T CABRIOLET	Sx Fuel line (filter to fuel rail)	143785	1
	Dx Fuel line (filter to fuel rail)	143784	1
	Fuel line (fuel rail to pressure regulator)	149812	2
348 TS / TB	Sx Fuel line (filter to fuel rail)	143787	1
	Dx Fuel line (filter to fuel rail)	143786	1
	Fuel line (fuel rail to pressure regulator)	149812	2

RECALL CAMPAIGN NO. 148

INTRODUCTION - Upper steering column locknut

SUBJECT: Recall Campaign No. 148
Ferrari 348 ts/tb, Mondial t and Testarossa Models
Upper steering column locknut

VEHICLES: All Ferrari 348 ts/tb, Mondial t & Testarossa Models with the following serial number ranges:

- Ferrari 348 ts/tb, Model Year 1990 and 1991, starting from serial number 85389 up to serial number 87898 included.
- Ferrari Mondial t coupe and cabriolet, Model Year 1990, starting from serial number 85927 up to serial number 87908 included.
- Ferrari Testarossa, Model Year 1990 and 1991, starting from serial number 85658 up to serial number 87483 included.

CONDITION: *The upper steering column locknut* may have been manufactured with a lower class of material and self-locking properties. This may result in a loss of tightening torque on the upper steering column fastener. Should such condition remain unnoticed and the use of the car be prolonged for an extensive period of time, loosening of the fastener could occur resulting in play in the steering system and consequential impairment of handling.

REMEDY: Replacement of the Upper steering column locknut with the improved self-locking nut (shown on Fig 1, page 11).

PARTS: Only one locknut (PN# 150428) required for each vehicle.

COST: An initial supply of new self-locking nuts will be shipped to your dealership. Your parts account will be charged accordingly. Additional self-locking nuts can be ordered from the Ferrari North America Parts Department in Englewood Cliffs, New Jersey.

LABOR: Operation No. 148
Time ALL MODELS - 0.2 hours

REIMBURSEMENT: On receipt of the correctly completed recall campaign claim (see Recall Claim form Instructions, page x).

INSTRUCTIONS FOR LOCKNUT REPLACEMENT

- A. Preliminary: The replacement self-locking nut (Fig.#1a) is supplied as a spare part (PN# 150428) by the Ferrari North America parts department.
- B. Procedure for installation
- 1) Cover interior (seat and carpeting).
 - 2) Remove 13mm locknut from upper steering column fastener and replace with new 13mm self locking nut (PN# 150428) as shown in fig.# 1 below.
 - 3) Check that the steering column shaft is properly inserted into the steering column extension. Fastener must go through the groove provided in the steering column shaft.
 - 4) Torque self-locking nut to 2.3 daNm (17 lbs/ft).
 - 5) Check for binding in steering system. If there is binding, check system for faults.
 - 6) Remove all covers from interior and insure that the area is clean.

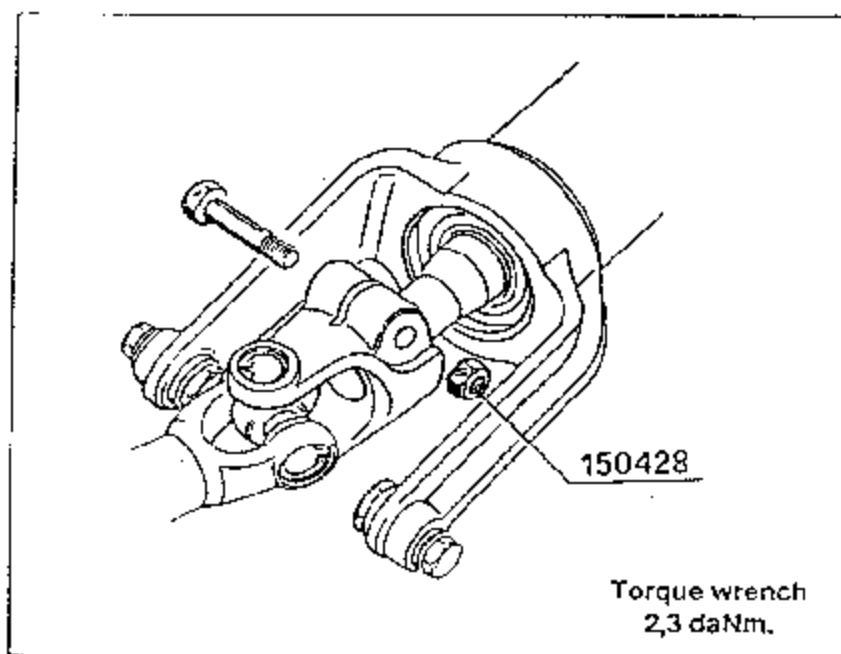

Fig.#1a

RECALL CAMPAIGN NO. 149

INTRODUCTION - Steering box extension fastener

SUBJECT: Recall Campaign No. 149
Ferrari 348 ts/tb Models
Steering box extension fastener

VEHICLES: All Ferrari 348 ts/tb Models with the following serial number ranges:

- Ferrari 348 ts/tb, Model Year 1989 and 1990, starting from serial number 82277 up to serial number 86212 included.

CONDITION: On 348 ts/tb vehicles with Vehicle Identification Number lower than 86212, the *steering box extension fastener* may have been manufactured with a lower class of material and self-locking properties. This may result in a loss of tightening torque on the upper steering column fastener. Should such condition remain unnoticed and the use of the car be prolonged for an extensive period of time, loosening of the fastener could occur resulting in play in the steering system and consequential impairment of handling.

REMEDY: Replacement of the Steering box extension fastener with the improved fastener (shown on Fig 1, page 13).

PARTS: One set of the following is required for each vehicle:

- | | | |
|-----------------|-------------|--------------|
| a) Fastner bolt | PN#125518 | Quantity - 1 |
| b) Locknut | PN#12574221 | Quantity - 1 |
| c) Washer | PN#12601274 | Quantity - 2 |

COST: An initial supply of these parts will be shipped to your dealership. Your parts account will be charged accordingly. Additional supplies of these parts can be ordered from the Ferrari North America Parts Department in Englewood Cliffs, New Jersey.

LABOR: Operation No. 149
Time 0.1 hours

REIMBURSEMENT: On receipt of the correctly completed recall campaign claim (see Recall Claim form Instructions, page x).

INSTRUCTIONS FOR FASTENER REPLACEMENT

- A. Preliminary: The replacement Fastener, bolt and washers (Fig.#1) are supplied as a spare parts by the Ferrari North America parts department using the part numbers listed on "parts" section of page 12.
- B. Procedure for installation
- 1) Cover interior (seat and carpeting).
 - 2) Move carpeting away from area of steering extension located under the dash at the base of the front cabin wall.
 - 3) Remove 10mm locknut from steering extension fastener and remove the fastener.
 - 4) Check that the steering box shaft is properly inserted into the steering column extension. Fastener must go through the groove provided in the steering box shaft.
 - 5) Install new fastening bolt along with the two washers and locknut as shown in fig. # 1 below.
 - 6) Torque Fastener nut to 1.2 daNm (9 lbs/ft).
 - 7) Replace carpeting around area of steering extension.
 - 8) Check for binding in steering system. If there is binding, check system for faults.
 - 9) Remove all covers from interior and insure that the area is clean.

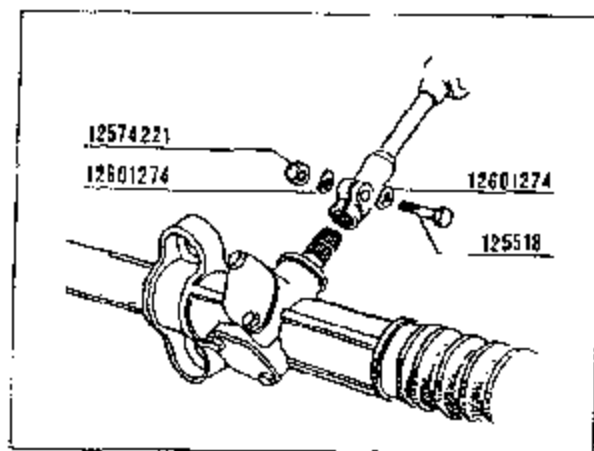

Fig.#1b

RECALL CLAIM FORM INSTRUCTIONS

FORWARD: The enclosed recall claim form has been numbered in these areas to be completed by your dealership. The numbered areas indicate the necessary information needed to process the claim and promptly credit your account.

INSTRUCTIONS: Information required to complete the recall claim form:

- | <u>Area</u> | <u>Instructions</u> |
|-------------|--|
| 1) | Enter your Ferrari 5-digit account number. |
| 2) | Enter vehicle mileage at time of repair. |
| 3) | Enter date of repair. |
| 4) | Enter Dealer claim calculations:

Parts Dealer Net
(Stock order price)
Parts Handling (33%)
Total Parts
Total Labor (hrs. x your approved WAR)
Amount Claimed |
| 5) | Enter name of authorized servicing Dealer. |
| 6) | Signature of Dealer or authorized designee. |
| 7) | Signature of vehicle's owner. |
| 8) | If VIN number listed in area 8 appears invalid, please show correct VIN in explanation space (9). |

No repair order need be attached for the campaign unless an owner has lost or never received a recall claim form. If this occurs, record all pertinent data, as required by the recall claim form, on a repair order. **Owner signs the repair order.**

The repair order must not be submitted until the Ferrari Representative can provide a blank recall claim form. Transfer pertinent data from repair order to the recall claim form. In OWNER area (7), write "Owner's signature on repair order no. ." **Attach the repair order to the claim form** and submit for reimbursement.

MAILING: In a Recall campaign form envelope (Print No. 3540) send recall claim



NORTH AMERICA, INC.

DOCUMENT NUMBER FOR FACTORY USE ONLY

RECALL CAMPAIGN FORM

RECALL CAMPAIGN NO.

SERV. ORDER NO.

YR. VEH. NO.

UNIT CODE

1

8

CLAIM NO.

SERIAL ORDER NO.

REPAIR DATE

MILEAGE

2

ALL RECALL CAMPAIGN WORK MUST BE ON AN APPROPRIATE RECALL CAMPAIGN CLAIM FORM. NOT A WORKMANSHIP CLAIM FORM. ATTACH REPAIR ORDER/DOCT TO BACK

COPY #2
PARTS COPY
RETAIN WITH PARTS

COPY #1
RETURN TO
FACTORY

OWNER:

OWNER'S SIGNATURE

7

Form No. 3780

CLAIMS PAID SUBJECT TO AUDIT AND PARTS INSPECTION

WE CERTIFY THE COMPLETION OF SERVICES REQUIREMENTS UNDER THE FEDERAL SAFETY CAMPAIGN ON THIS VEHICLE

AUTHORIZED SERVICE DEALER NAME

5

6

REPAIR SUBJECT

REJECT
RETURN

9

OPER. NO. HOURS

OFFICIAL FERRARI QUALIFIER
PARTS CHECKER

NET
PARTS HANDLING
TOTAL PARTS
TOTAL LABOR
SUBLET

4

TOTAL
AMOUNT CLAIMED

Ferrari

Ferrari North America, Inc.
250 Sylvan Avenue
Englewood Cliffs, NJ 07632
201-816-2600
TLX: 248021
FAX: 201-816-2626

June 1992

Letter "A":

This notice is sent to you in accordance with the requirements of the National Traffic and Motor Vehicles Safety Act.

Ferrari S.p.A., the manufacturer of Ferrari automobiles, has determined that certain defects may exist in particular 1989 and 1990 model year Ferrari vehicles.

- 1) On 348 ts/tb vehicles with Vehicle Identification Number lower than 88386, the aluminum fittings on certain *fuel injection lines* may corrode under extreme environmental conditions. Should such condition remain unnoticed, the result could be breakage of the aluminum fuel line fitting resulting in fuel leakage. As with any type of fuel system leakage, the possibility of a vehicle engine fire may exist.
- 2) On 348 ts/tb vehicles with Vehicle Identification Number lower than 86232, the *steering box extension fastener* may have been manufactured with a lower class of material and self-locking properties. This may result in a loss of tightening torque on the upper steering column fastener. Should such condition remain unnoticed and the use of the car be prolonged for an extensive period of time, loosening of the fastener could occur resulting in play in the steering system and consequential impairment of handling.

Since your car is among those potentially affected by the above conditions, we kindly ask you to contact any Ferrari Authorized Dealer immediately in order to arrange an inspection of your automobile, and if necessary, the Dealer will perform the required modifications.

The corrective action for the above listed repairs will be performed free of charge and will require approximately 1.5 hours, however please plan to leave your vehicle with the dealer all day to allow the dealer some flexibility for scheduling your repairs.

By the time you receive this letter, the Authorized Ferrari Dealer will have been supplied with the instructions and parts to perform the repairs.

Cont.....





NORTH AMERICA, INC.

DOCUMENT NUMBER FOR FACTORY USE ONLY

RECALL CAMPAIGN FORM

COPY #1 RETURN TO FACTORY		COPY #3 PARTS COPY RETAIN WITH PARTS	
OWNER: OWNERS SIGNATURE (7)		CLAIM NO. (1)	
CLAIM NO. PAID SUBJECT TO ALGT. AND PARTS INSPECTION		VEH. VIN. NO. (8)	
WE CERTIFY THE COMPLETION OF SERVICES RECOMMENDED UNDER THE RECALL CAMPAIGN ON THIS VEHICLE.		RECALL CAMPAIGN NO.	
AUTHORIZED SERVICE DEALER NAME (5) SIGNATURE (6)		REPAIR DATE (3) / (3) / (3) WUP CODE (2)	
FACTORY CODES: <input type="checkbox"/> REJECT <input type="checkbox"/> RETURN		ALL RECALL CAMPAIGN WORK MUST BE DONE APPROPRIATE RECALL CAMPAIGN CLAIM FORM WITH REPAIR ORDER COPY TO EACH	
OPER. NO. HOURS		PARTS LABOR	
LEADERSHIP NAME PARTS LEADER NET PARTS & LABOR TOTAL PARTS TOTAL LABOR SUBLET TOTAL AMOUNT CLAIMED		(4)	

Print. No. 3740

Also, Ferrari S.p.A. has introduced a number of improvements into production that may be applicable to your vehicle. While your vehicle is at your Ferrari authorized dealer for the above listed recall campaign items, we would like the opportunity to extend these improvements to your car free of charge.

If the Dealer fails or is unable to make the necessary repairs free of charge within a reasonable time, you should inform the National Headquarters Office of Ferrari North America, Inc.

250 Sylvan Avenue,
Englewood Cliffs, NJ 07632
(201) 816-2651 (National Technical Office)
(201) 816-2652 (Customer Relations)

Although we urge you to immediately call one of the numbers indicated above, if the vehicle is not repaired free of charge or within a reasonable time, you may also contact the Administrator of the National Traffic Safety Administration in Washington, D.C. 20590 or call the Auto Safety Hot line at 1-800-424-9393.

We urge you to comply with this notice promptly and we apologize for any inconvenience this may cause you.

Sincerely,

Kenneth McCay
Technical Director
Ferrari North America, Inc.



Ferrari

Ferrari North America, Inc.
250 Sylvan Avenue
Englewood Cliffs, NJ 07632
201-816-2600
TLX: 248021
FAX: 201-816-2626

June 1992

Letter "B":

This notice is sent to you in accordance with the requirements of the National Traffic and Motor Vehicles Safety Act.

Ferrari S.p.A., the manufacturer of Ferrari automobiles, has determined that certain defects may exist in particular 1990 model year Ferrari vehicles.



- 1) On 348 ts/tb vehicles with Vehicle Identification Number lower than 88386, the aluminum fittings on certain *fuel Injection lines* may corrode under extreme environmental conditions. Should such condition remain unnoticed, the result could be breakage of the aluminum fuel line fitting resulting in fuel leakage. As with any type of fuel system leakage, the possibility of a vehicle engine fire may exist.
- 2) On 348 ts/tb vehicles with Vehicle Identification Number lower than 86232, the *upper steering column locknut* may have been manufactured with a lower class of material and self-locking properties. This may result in a loss of tightening torque on the upper steering column fastener. Should such condition remain unnoticed and the use of the car be prolonged for an extensive period of time, loosening of the fastener could occur resulting in play in the steering system and consequential impairment of handling.
- 3) On 348 ts/tb vehicles with Vehicle Identification Number lower than 86232, the *steering box extension fastener* may have been manufactured with a lower class of material and self-locking properties. This may result in a loss of tightening torque on the steering box extension fastener. Should such condition remain unnoticed and the use of the car be prolonged for an extensive period of time, loosening of the fastener could occur resulting in play in the steering system and consequential impairment of handling.

Since your car is among those potentially affected by the above conditions, we kindly ask you to contact any Ferrari Authorized Dealer immediately in order to arrange an inspection of your automobile, and if necessary, the Dealer will perform the required modifications.

The corrective action for the above listed repairs will be performed free of charge and will require approximately 1.5 hours, however please plan to leave your vehicle with the dealer all day to allow the dealer some flexibility for scheduling your repairs.

Cont.....

By the time you receive this letter, the Authorized Ferrari Dealer will have been supplied with the instructions and parts to perform the repairs.

Also, Ferrari S.p.A. has introduced a number of improvements into production that may be applicable to your vehicle. While your vehicle is at your Ferrari authorized dealer for the above listed recall campaign items, we would like the opportunity to extend these improvements to your car free of charge.

If the Dealer fails or is unable to make the necessary repairs free of charge within a reasonable time, you should inform the National Headquarters Office of Ferrari North America, Inc.

250 Sylvan Avenue,
Englewood Cliffs, NJ 07632
(201) 816-2651 (National Technical Office)
(201) 816-2652 (Customer Relations)

Although we urge you to immediately call one of the numbers indicated above, if the vehicle is not repaired free of charge or within a reasonable Time, you may also contact the Administrator of the National Traffic Safety Administration in Washington, D.C. 20590 or call the Auto Safety Hot line at 1-800-424-9393.

We urge you to comply with this notice promptly and we apologize for any inconvenience this may cause you.

Sincerely,

Kenneth McCay
Technical Director
Ferrari North America, Inc.



Ferrari

Ferrari North America, Inc.
250 Sylvan Avenue
Englewood Cliffs, NJ 07632
201 816-2800
TLX: 248021
FAX: 201-816-2626

June 1992

Letter "C":

This notice is sent to you in accordance with the requirements of the National Traffic and Motor Vehicles Safety Act.

Ferrari S.p.A., the manufacturer of Ferrari automobiles, has determined that certain defects may exist in particular 1990 model year Ferrari vehicles.

- 1) On 348 ts/tb vehicles with Vehicle Identification Number lower than 88386, the aluminum fittings on certain *fuel injection lines* may corrode under extreme environmental conditions. Should such condition remain unnoticed, the result could be breakage of the aluminum fuel line fitting resulting in fuel leakage. As with any type of fuel system leakage, the possibility of a vehicle engine fire may exist.
- 2) On 348 ts/tb vehicles with Vehicle Identification Number lower than 86232, the *upper steering column locknut* may have been manufactured with a lower class of material and self-locking properties. This may result in a loss of tightening torque on the upper steering column fastener. Should such condition remain unnoticed and the use of the car be prolonged for an extensive period of time, loosening of the fastener could occur resulting in play in the steering system and consequential impairment of handling.

Since your car is among those potentially affected by the above conditions, we kindly ask you to contact any Ferrari Authorized Dealer immediately in order to arrange an inspection of your automobile, and if necessary, the Dealer will perform the required modifications.

The corrective action for the above listed repairs will be performed free of charge and will require approximately 1.5 hours, however please plan to leave your vehicle with the dealer all day to allow the dealer some flexibility for scheduling your repairs.

By the time you receive this letter, the Authorized Ferrari Dealer will have been supplied with the instructions and parts to perform the repairs.

Also, Ferrari S.p.A. has introduced a number of improvements into production that may be applicable to your vehicle. While your vehicle is at your Ferrari authorized dealer for the above listed recall campaign items, we would like the opportunity to extend these improvements to your car free of charge.



If the Dealer fails or is unable to make the necessary repairs free of charge within a reasonable time, you should inform the National Headquarters Office of Ferrari North America, Inc.

250 Sylvan Avenue,
Englewood Cliffs, NJ 07632
(201) 816-2651 (National Technical Office)
(201) 816-2652 (Customer Relations)

Although we urge you to immediately call one of the numbers indicated above, if the vehicle is not repaired free of charge or within a reasonable Time, you may also contact the Administrator of the National Traffic Safety Administration in Washington, D.C. 20590 or call the Auto Safety Hot line at 1-800-424-9393.

We urge you to comply with this notice promptly and we apologize for any inconvenience this may cause you.

Sincerely,

Kenneth McCay
Technical Director
Ferrari North America, Inc.



Ferrari

Ferrari North America, Inc.
250 Sylvan Avenue
Englewood Cliffs, NJ 07632
201-816-2600
TLX: 248021
FAX: 201-816-2626

June 1992

Letter "D":

This notice is sent to you in accordance with the requirements of the National Traffic and Motor Vehicles Safety Act.

Ferrari S.p.A., the manufacturer of Ferrari automobiles, has determined that certain defects may exist in particular 1990 and 1991 model year Ferrari vehicles.

On 348 ts/tb vehicles with Vehicle Identification Number lower than 87898, the *upper steering column locknut* may have been manufactured with a lower class of material and self-locking properties. This may result in a loss of tightening torque on the upper steering column fastener. Should such condition remain unnoticed and the use of the car be prolonged for an extensive period of time, loosening of the fastener could occur resulting in play in the steering system and consequential impairment of handling.

Since your car is among those potentially affected by the above condition, we kindly ask you to contact any Ferrari Authorized Dealer immediately in order to arrange an inspection of your automobile, and if necessary, the Dealer will perform the required modification.

The corrective action for the above listed repair will be performed free of charge and will require approximately 1.5 hours, however please plan to leave your vehicle with the dealer all day to allow the dealer some flexibility for scheduling your repairs.

By the time you receive this letter, the Authorized Ferrari Dealer will have been supplied with the instructions and parts to perform the repair.

Also, Ferrari S.p.A. has introduced a number of improvements into production that may be applicable to your vehicle. While your vehicle is at your Ferrari authorized dealer for the above listed recall campaign items, we would like the opportunity to extend these improvements to your car free of charge.



If the Dealer fails or is unable to make the necessary repairs free of charge within a reasonable time, you should inform the National Headquarters Office of Ferrari North America, Inc.

250 Sylvan Avenue,
Englewood Cliffs, NJ 07632
(201) 816-2651 (National Technical Office)
(201) 816-2652 (Customer Relations)

Although we urge you to immediately call one of the numbers indicated above, if the vehicle is not repaired free of charge or within a reasonable Time, you may also contact the Administrator of the National Traffic Safety Administration in Washington, D.C. 20590 or call the Auto Safety Hot line at 1-800-424-9393.

We urge you to comply with this notice promptly and we apologize for any inconvenience this may cause you.

Sincerely,

Kenneth McCay
Technical Director
Ferrari North America, Inc.



Ferrari

Ferrari North America, Inc.
250 Sylvan Avenue
Englewood Cliffs, NJ 07632
201-816-2600
TLX: 248021
FAX: 201-816-2626

June 1992

Letter "E":

This notice is sent to you in accordance with the requirements of the National Traffic and Motor Vehicles Safety Act.

Ferrari S.p.A., the manufacturer of Ferrari automobiles, has determined that certain defects may exist in particular 1990 and 1991 model year Ferrari vehicles.

On Testarossa vehicles with Vehicle Identification Number lower than 86232, the *upper steering column locknut* may have been manufactured with a lower class of material and self-locking properties. This may result in a loss of tightening torque on the upper steering column fastener. Should such condition remain unnoticed and the use of the car be prolonged for an extensive period of time, loosening of the fastener could occur resulting in play in the steering system and consequential impairment of handling.

Since your car is among those potentially affected by the above condition, we kindly ask you to contact any Ferrari Authorized Dealer immediately in order to arrange an inspection of your automobile, and if necessary, the Dealer will perform the required modification.

The corrective action for the above listed repair will be performed free of charge and will require approximately 1.5 hours, however please plan to leave your vehicle with the dealer all day to allow the dealer some flexibility for scheduling your repair.

By the time you receive this letter, the Authorized Ferrari Dealer will have been supplied with the instructions and parts to perform the repair.

If the Dealer fails or is unable to make the necessary repair free of charge within a reasonable time, you should inform the National Headquarters Office of Ferrari North America, Inc.

250 Sylvan Avenue,
Englewood Cliffs, NJ 07632
(201) 816-2651 (National Technical Office)
(201) 816-2652 (Customer Relations)

Cont.....



Although we urge you to immediately call one of the numbers indicated, if the vehicle is not repaired free of charge or within a reasonable Time, you may also contact the Administrator of the National Traffic Safety Administration in Washington, D.C. 20590 or call the Auto Safety Hot line at 1-800-424-9393.

We urge you to comply with this notice promptly and we apologize for any inconvenience this may cause you.



Sincerely,

Kenneth McCay
Technical Director
Ferrari North America, Inc.

Ferrari

Ferrari North America, Inc.
250 Sylvan Avenue
Englewood Cliffs, NJ 07632
201-816-2600
TLX: 248021
FAX: 201-816-2626

June 1992

Letter "F":

This notice is sent to you in accordance with the requirements of the National Traffic and Motor Vehicles Safety Act.

Ferrari S.p.A., the manufacturer of Ferrari automobiles, has determined that certain defects may exist in particular 1990 model year Ferrari vehicles.

On Mondial t coupe / cabriolet vehicles with Vehicle Identification Number lower than 88386, the aluminum fittings on certain *fuel injection lines* may corrode under extreme environmental conditions. Should such condition remain unnoticed, the result could be breakage of the aluminum fuel line fitting resulting in fuel leakage. As with any type of fuel system leakage, the possibility of a vehicle engine fire may exist.

Since your car is among those potentially affected by the above condition, we kindly ask you to contact any Ferrari Authorized Dealer immediately in order to arrange an inspection of your automobile, and if necessary, the Dealer will perform the required modification.

The corrective action for the above listed repair will be performed free of charge and will require approximately 1.5 hours, however please plan to leave your vehicle with the dealer all day to allow the dealer some flexibility for scheduling your repair.

By the time you receive this letter, the Authorized Ferrari Dealer will have been supplied with the instructions and parts to perform the repair.

If the Dealer fails or is unable to make the necessary repair free of charge within a reasonable time, you should inform the National Headquarters Office of Ferrari North America, Inc.

250 Sylvan Avenue,
Englewood Cliffs, NJ 07632
(201) 816-2651 (National Technical Office)
(201) 816-2652 (Customer Relations)

Cont.....



Although we urge you to immediately call one of the numbers indicated, if the vehicle is not repaired free of charge or within a reasonable Time, you may also contact the Administrator of the National Traffic Safety Administration in Washington, D.C. 20590 or call the Auto Safety Hot line at 1-800-424-9393.

We urge you to comply with this notice promptly and we apologize for any inconvenience this may cause you.

Sincerely,



Kenneth McCay
Technical Director
Ferrari North America, Inc.

Ferrari

Ferrari North America, Inc.
250 Sylvan Avenue
Englewood Cliffs, NJ 07632
201-816-2600
TLX: 248021
FAX: 201-816-2626

June 1992

Letter "G":

This notice is sent to you in accordance with the requirements of the National Traffic and Motor Vehicles Safety Act.

Ferrari S.p.A., the manufacturer of Ferrari automobiles, has determined that certain defects may exist in particular 1990 model year Ferrari vehicles.

- 1) On Mondial t coupe / cabriolet vehicles with Vehicle Identification Number lower than 88386, the aluminum fittings on certain *fuel injection lines* may corrode under extreme environmental conditions. Should such condition remain unnoticed, the result could be breakage of the aluminum fuel line fitting resulting in fuel leakage. As with any type of fuel system leakage, the possibility of a vehicle engine fire may exist.
- 2) On Mondial t coupe / cabriolet vehicles with Vehicle Identification Number lower than 86232, the *upper steering column locknut* may have been manufactured with a lower class of material and self-locking properties. This may result in a loss of tightening torque on the upper steering column fastener. Should such condition remain unnoticed and the use of the car be prolonged for an extensive period of time, loosening of the fastener could occur resulting in play in the steering system and consequential impairment of handling.

Since your car is among those potentially affected by the above conditions, we kindly ask you to contact any Ferrari Authorized Dealer immediately in order to arrange an inspection of your automobile, and if necessary, the Dealer will perform the required modifications.

The corrective action for the above listed repairs will be performed free of charge and will require approximately 1.5 hours, however please plan to leave your vehicle with the dealer all day to allow the dealer some flexibility for scheduling your repairs.

By the time you receive this letter, the Authorized Ferrari Dealer will have been supplied with the instructions and parts to perform the repairs.

If the Dealer fails or is unable to make the necessary repairs free of charge within a reasonable time, you should inform the National Headquarters Office of Ferrari North America, Inc.

250 Sylvan Avenue,
Englewood Cliffs, NJ 07632
(201) 816-2651 (National Technical Office)
(201) 816-2652 (Customer Relations)

Cont.....



Although we urge you to immediately call one of the numbers indicated, if the vehicle is not repaired free of charge or within a reasonable Time, you may also contact the Administrator of the National Traffic Safety Administration in Washington, D.C. 20590 or call the Auto Safety Hot line at 1-800-424-9393.

We urge you to comply with this notice promptly and we apologize for any inconvenience this may cause you



Sincerely,

Kenneth McCay
Technical Director
Ferrari North America, Inc

Ferrari

Ferrari North America, Inc.
250 Sylvan Avenue
Englewood Cliffs, NJ 07632
201-816-2600
TLX: 248021
FAX: 201-816-2625

June 1992

Letter "F":

This notice is sent to you in accordance with the requirements of the National Traffic and Motor Vehicles Safety Act.

Ferrari S.p.A., the manufacturer of Ferrari automobiles, has determined that certain defects may exist in particular 1990 model year Ferrari vehicles.

On Mondial coupe / cabriolet vehicles with Vehicle Identification Number lower than 88386, the aluminum fittings on certain *fuel Injection lines* may corrode under extreme environmental conditions. Should such condition remain unnoticed, the result could be breakage of the aluminum fuel line fitting resulting in fuel leakage. As with any type of fuel system leakage, the possibility of a vehicle engine fire may exist.

Since your car is among those potentially affected by the above condition, we kindly ask you to contact any Ferrari Authorized Dealer immediately in order to arrange an inspection of your automobile, and if necessary, the Dealer will perform the required modification.

The corrective action for the above listed repair will be performed free of charge and will require approximately 1.5 hours, however please plan to leave your vehicle with the dealer all day to allow the dealer some flexibility for scheduling your repair.

By the time you receive this letter, the Authorized Ferrari Dealer will have been supplied with the instructions and parts to perform the repair.

If the Dealer fails or is unable to make the necessary repair free of charge within a reasonable time, you should inform the National Headquarters Office of Ferrari North America, Inc.

250 Sylvan Avenue,
Englewood Cliffs, NJ 07632
(201) 816-2651 (National Technical Office)
(201) 816-2652 (Customer Relations)

Cont.....



Although we urge you to immediately call one of the numbers indicated, if the vehicle is not repaired free of charge or within a reasonable Time, you may also contact the Administrator of the National Traffic Safety Administration in Washington, D.C. 20590 or call the Auto Safety Hot line at 1-800-424-9393.

We urge you to comply with this notice promptly and we apologize for any inconvenience this may cause you.



Sincerely,

Kenneth McCay
Technical Director
Ferrari North America, Inc.

Ferrari

Ferrari North America, Inc.
250 Sylvan Avenue
Englewood Cliffs, NJ 07632
201-816-2600
TLX: 248021
FAX: 201-816-2626

June 1992

Letter "G":

This notice is sent to you in accordance with the requirements of the National Traffic and Motor Vehicles Safety Act.

Ferrari S.p.A., the manufacturer of Ferrari automobiles, has determined that certain defects may exist in particular 1990 model year Ferrari vehicles.



- 1) On Mondial t coupe / cabriolet vehicles with Vehicle Identification Number lower than 88386, the aluminum fittings on certain *fuel injection lines* may corrode under extreme environmental conditions. Should such condition remain unnoticed, the result could be breakage of the aluminum fuel line fitting resulting in fuel leakage. As with any type of fuel system leakage, the possibility of a vehicle engine fire may exist.
- 2) On Mondial t coupe / cabriolet vehicles with Vehicle Identification Number lower than 86232, the *upper steering column locknut* may have been manufactured with a lower class of material and self-locking properties. This may result in a loss of tightening torque on the upper steering column fastener. Should such condition remain unnoticed and the use of the car be prolonged for an extensive period of time, loosening of the fastener could occur resulting in play in the steering system and consequential impairment of handling.

Since your car is among those potentially affected by the above conditions, we kindly ask you to contact any Ferrari Authorized Dealer immediately in order to arrange an inspection of your automobile, and if necessary, the Dealer will perform the required modifications.

The corrective action for the above listed repairs will be performed free of charge and will require approximately 1.5 hours, however please plan to leave your vehicle with the dealer all day to allow the dealer some flexibility for scheduling your repairs.

By the time you receive this letter, the Authorized Ferrari Dealer will have been supplied with the instructions and parts to perform the repairs.

If the Dealer fails or is unable to make the necessary repairs free of charge within a reasonable time, you should inform the National Headquarters Office of Ferrari North America, Inc.

250 Sylvan Avenue,
Englewood Cliffs, NJ 07632
(201) 816-2651 (National Technical Office)
(201) 816-2652 (Customer Relations)

Cont.....

Although we urge you to immediately call one of the numbers indicated, if the vehicle is not repaired free of charge or within a reasonable Time, you may also contact the Administrator of the National Traffic Safety Administration in Washington, D.C. 20590 or call the Auto Safety Hot line at 1-800-424-9393.

We urge you to comply with this notice promptly and we apologize for any inconvenience this may cause you.

Sincerely,

Kenneth McCay
Technical Director
Ferrari North America, Inc.



Ferrari

Ferrari North America, Inc.
250 Sylvan Avenue
Englewood Cliffs, NJ 07632
201-816-2600
TLX: 248021
FAX: 201-816-2626

May 11, 1992

Mr. Charles L. Gauthier, Director
Office of Defects Investigation
National Highway Traffic Safety Administration
Washington, D.C. 20590

Dear Director:

Please find herewith enclosed Vehicle Safety Defect Initial Information Reports with respect to three Recall Campaigns which we are initiating in order to correct the following.

- 92V-071
- 1) On vehicles with Vehicle Identification Number lower than 88386, the aluminum fuel line fittings on certain fuel injection lines may corrode under extreme environmental conditions. Should such condition remain unnoticed, the result could be breakage of the aluminum fuel line fitting resulting in fuel leakage. As with any type of fuel system leakage, the possibility of a vehicle engine fire may exist.
 - ~~2) On vehicles with Vehicle Identification Number lower than 87898, the Upper steering column locknut may have been manufactured with a lower class of material and self-locking properties. Should such condition remain unnoticed, loosening of the locknut could occur resulting in excessive play in the steering system and consequential impairment of handling.~~
 - ~~3) On vehicles with Vehicle Identification Number lower than 86232, the Steering box extension fastener may have been manufactured with a lower class of material. Should such condition remain unnoticed, loosening of the fastener could occur resulting in excessive play in the steering system and consequential impairment of handling.~~
- 92V-072
- 92V-073

The corrective action will require approximately 1.5 hours.

For the above campaign, it is our intention to notify the Ferrari Dealers with a comprehensive letter explaining the remedy; furthermore it is our intention to notify each vehicle owner with a single letter mentioning the recall modification required.

Draft copies of the letters that Ferrari North America, Inc. will send to the owners and to the Ferrari Dealers along with the technical instructions will be submitted to your office by may 15, 1992.

Yours truly,



Kenneth W. McCay
Technical Director
Ferrari North America, Inc.

Enclosures

FERRARI NORTH AMERICA, INC.
250 SYLVAN AVENUE
ENGLEWOOD CLIFFS, N.J. 07632

**VEHICLE SAFETY DEFECT
INITIAL INFORMATION REPORT**

348 ts/tb & Mondial t - Fuel Injection lines
Recall No. 147

A) DESCRIPTION OF DEFECT:

On vehicles with Vehicle Identification Number lower than 88386, the aluminum fuel line fittings on certain fuel injection lines may corrode under extreme environmental conditions. Should such condition remain unnoticed, the result could be breakage of the aluminum fuel line fitting resulting in fuel leakage.

B) CHRONOLOGY OF EVENTS WHICH LED TO DETERMINATION OF A SAFETY DEFECT:

As a result of extended durability testing, Ferrari S.p.A. discovered that the aluminum fittings on certain fuel injection lines may corrode if exposed extreme environmental conditions.

C) MEASURES TO BE TAKEN TO REPAIR VEHICLE:

The remedy consists in the replacement of the four fuel injection lines with modified fuel lines which are now constructed with a corrosion resistant coating to prevent fuel line surface corrosion. The operation is free-of-charge for the vehicle owner, and will require approximately 50 hours for 348 ts/tb and 1.2 hours for Mondial t coupe and cabriolet.

ESTIMATED INITIATION OF CORRECTIVE ACTION: JUNE 1982

92V-071

**VEHICLE SAFETY DEFECT
INITIAL INFORMATION REPORT**
Fuel injection lines
Recall No. 147

Date submitted: May 14, 1992
 Date received: May 11, 1992
 Campaign No.: 147
 Campaign Date: June 1992

ENCLOSED MFG. DATES

<u>MAKE</u>	<u>MODEL</u>	<u>MODEL YEAR</u>	<u>NO. OF VEHICLES</u>	<u>FROM</u>	<u>THROUGH</u>	<u>OTHER VEHICLE IDENTIFICATION</u>
FERRARI	348 TS / TB	1989	134	JULY 1989	JAN. 1990	
FERRARI	MONDIAL T CPE / CAB	1989	208	MAY 1989	AUG. 1989	
FERRARI	348 TS / TB	1990	377	MAR. 1990	DEC. 1990	
FERRARI	MONDIAL T CAB	1990	93	FEB. 1990	DEC. 1990	