



Stacy L. Balzer
Operating Director
Service Engineering Operations
Ford Customer Service Division

Ford Motor Company
P. O. Box 1904
Dearborn, Michigan 48121

September 20, 2023

TO: All U.S. Ford and Lincoln Dealers

**SUBJECT: NEW VEHICLE RECOMMENDED DELIVERY HOLD
Customer Satisfaction Program 23B19
Certain 2023 Model Year F-150 Raptor-R Vehicles
Front Axle Vibration Bumper Inspection**

PROGRAM TERMS

This program will be in effect through September 30, 2024. There is no mileage limit for this program.

AFFECTED VEHICLES

Vehicle	Model Year	Assembly Plant	Build Dates
F-150	2023	Dearborn	September 21, 2022 through March 9, 2023

US population of affected vehicles: 1,308. Affected vehicles are identified in OASIS and FSA VIN Lists.

Note: Some vehicles may be in the process of being repaired at the plant. Monitor OASIS before opening an RO and/or beginning a repair. Parts purchased for an FSA can be returned for credit if required. See the EXCESS STOCK RETURN details in Labor Allowances and Parts Ordering Information for more information.

REASON FOR THIS PROGRAM

In some of the affected vehicles, the Front Axle Vibration Bumper may have been installed improperly. A customer with an improperly installed vibration bumper may experience audible Noise, Vibration, and Harshness (NVH) issues while operating the vehicle under certain 4X4 or off-roading conditions.

SERVICE ACTION

Before delivering any new in-stock vehicles involved in this program, dealers are to inspect the Front Axle Vibration Bumper for the correct orientation. If the vibration bumper is not in the correct orientation, dealers are to remove the vibration bumper and re-install it into the correct position. This service must be performed on all affected vehicles at no charge to the vehicle owner. For new vehicle storage guidelines, refer to EFC13033.

To maximize customer satisfaction, ensure to check OASIS for any other open customer satisfaction program(s) against this VIN, and schedule the customer in for service only after parts are available for all open programs.

To assist vehicle owners to have this repair completed, dealers should:

- Arrange to pick up the owner's vehicle and drive it to the dealership for repairs.
- Re-deliver the owner's vehicle after repairs have been completed.
- Pick-up and delivery should be made available to all customers. Refer to the Claiming section for further details.

OWNER NOTIFICATION MAILING SCHEDULE

Owner letters are expected to be mailed the week of October 2, 2023. Dealers should repair any affected vehicles that arrive at their dealerships, whether or not the customer has received a letter.

ATTACHMENTS

- Administrative Information
- Labor Allowances and Parts Ordering Information
- Technical Instructions
- Mobile Service Repair Assessment
- Mobile or Pick-Up and Delivery Repair Record
- Owner Notification Letter

QUESTIONS & ASSISTANCE

For questions and assistance, contact the Special Service Support Center (SSSC) via the SSSC Web Contact Site. The SSSC Web Contact Site can be accessed through the Professional Technician System (PTS) website using the SSSC link listed at the bottom of the OASIS VIN report screen or listed under the SSSC tab.

Sincerely,



Stacy L. Balzer

Customer Satisfaction Program 23B19**MOBILE SERVICE REPAIR ASSESSMENT LEVEL**

Ⓢ - Not a Mobile Service Repair

OASIS ACTIVATION

OASIS will be activated on September 20, 2023.

FSA VIN LISTS ACTIVATION

FSA VIN Lists will be available through <https://web.fsavinlists.dealerconnection.com> on September 20, 2023. Owner names and addresses will be available by October 20, 2023.

NOTE: Your FSA VIN Lists may contain owner names and addresses obtained from motor vehicle registration records. The use of such motor vehicle registration data for any purpose other than in connection with this program is a violation of law in several states, provinces, and countries. Accordingly, you must limit the use of this listing to the follow-up necessary to complete this service action.

SOLD VEHICLES

- Owners of affected vehicles will be directed to dealers for repairs.
- Immediately contact any of your affected customers whose vehicles are not on your VIN list but are identified in OASIS. Give the customer a copy of the Owner Notification Letter (when available) and schedule a service date.
- Correct other affected vehicles identified in OASIS which are brought to your dealership.
- Dealers are to prioritize repairs of customer vehicles over repairs of new and used vehicle inventory.

STOCK VEHICLES

- Correct all affected units in your new vehicle inventory before delivery.
- Use OASIS to identify any affected vehicles in your used vehicle inventory.

BRANDED / SALVAGED TITLE VEHICLES

Affected branded / salvaged vehicles are eligible for this service action.

OWNER REFUNDS

Refunds are not approved for this program.

RENTAL VEHICLES

Rental vehicles should not be required for this program. If you have a unique owner circumstance or multiple programs, a rental vehicle may be approved. Please contact the SSSC via the SSSC Web Contact Site.

Customer Satisfaction Program 23B19

PICK-UP AND DELIVERY- Participating Dealers

Dealers participating in the Remote Experience Program:

- Refer to EFC12071, 2023 Remote Experience Program, Pickup & Delivery (PDL) Offset section for additional details.

PICK-UP AND DELIVERY- Non-participating Dealers

Dealers not participating in the 2023 Remote Experience Program for Pick-up & Delivery are authorized to claim unique services for completing this program.

- Dealers are authorized to claim one-half labor hour per repair visit for vehicle pick-up & delivery services. Refer to Labor Allowances for details.
- Dealers must retain a Vehicle Pick-up & Delivery Record with the repair order documentation.

ADDITIONAL REPAIR (LABOR TIME AND/OR PARTS)

Additional repairs identified as necessary to complete the FSA should be managed as follows:

- For related damage and access time requirements, refer to the Warranty and Policy Manual / Section 6 – Ford & Lincoln Program Policies / General Information & Special Circumstances for FSAs / Related Damage.
- For vehicles within new vehicle bumper-to-bumper warranty coverage, no SSSC approval is required, although related damage must be on a separate repair line with the “Related Damage” radio button checked.
 - Ford vehicles – 3 years or 36,000 miles
- For vehicles outside new vehicle bumper-to-bumper warranty coverage, submit an Approval Request to the SSSC Web Contact Site prior to completing the repair.

CLAIMS PREPARATION AND SUBMISSION

- **Claim Entry:** Enter claims using Dealer Management System (DMS) or One Warranty Solution (OWS) online.
 - When entering claims:
 - Claim type 31: Field Service Action
 - Sub Code: 23B19
 - Customer Concern Code (CCC): N18 – Unusual transmission noise, and/or (NVH)
 - Condition Code (CC): Improper Assembly – 12
 - Causal Part Number: 3020, Quantity 0
 - For additional claims preparation and submission information, refer to the Recall and Customer Satisfaction Program (CSP) Repairs in the OWS User Guide.
- **Related Damage/Additional labor and/or parts:** Must be claimed as Related Damage on a separate repair line from the FSA with same claim type and sub code as described in Claim Entry above.

IMPORTANT: Click the Related Damage Indicator radio button.

Customer Satisfaction Program 23B19

CLAIMS PREPARATION AND SUBMISSION (Continued)

- **Rentals:** For rental vehicle claiming, follow Extended Service Plan (ESP) guidelines for dollar amounts. Enter the total amount of the rental expense under the Miscellaneous Expense code RENTAL.
- **Pickup & Delivery:**
 - Dealers participating in the Remote Experience Program –
 - Refer to EFC12071, 2023 Remote Experience Program, Pickup & Delivery (PDL) Offset section for additional details.
 - Dealers NOT participating in the Remote Experience Program –
 - Dealers are authorized to claim one-half labor hour per repair for vehicle pick-up and delivery services.
 - Dealers must retain a Vehicle Pick-up and Delivery Record with the repair order documentation.

Customer Satisfaction Program 23B19

LABOR ALLOWANCES

Description	Labor Operation	Labor Time
Inspect Front Axle Vibration Bumper orientation - PASS - Front Axle Vibration Bumper is in the correct orientation, no further action is required.	23B19A	0.3 Hours
Inspect Front Axle Vibration Bumper orientation - FAIL - Front Axle Vibration Bumper is not in the correct orientation, remove and re-install vibration bumper in the correct orientation.	23B19B	0.5 Hours
Vehicle Pick-up and Delivery Allowance: This allowance is only for <u>non-eligible</u> 2023 Remote Experience Program dealers. NOTE: This allowance is for dealer-performed vehicle pick-up/delivery for dealership repairs only. Can only be claimed once per repair visit, regardless of outstanding FSAs repaired.	23B19PP	0.5 Hours

PARTS REQUIREMENTS / ORDERING INFORMATION

Parts are not required to complete this repair.



Ford Motor Company
Ford Customer Service Division
P. O. Box 1904
Dearborn, Michigan 48121

October 2023

Customer Satisfaction Program(s): 23B17, 23B18, 23B19, 23B20, 23B25
Mr. John Sample
123 Main Street
Anywhere, USA 12345

Your Vehicle Identification Number (VIN): 12345678901234567

At Ford Motor Company, we are committed not only to building high-quality, dependable products but also to building a community of happy, satisfied customers. To demonstrate that commitment, we are providing one or more a no-charge Customer Satisfaction Program(s) for your vehicle with the VIN shown above.

Why are you receiving this notice? Your vehicle may have one or more customer satisfaction program(s) open.

What is the effect? Depending on which program(s) apply, the effect on your vehicle may include oil/coolant leaks, unwanted noise from the front end and/or unwanted noise from underneath the vehicle.
To find the specific program(s) information for your vehicle, you can check service section of your FordPass app, visit the website below, or use the QR code: <https://www.ford.com/support/recalls>



What will Ford and your dealer do? In the interest of customer satisfaction, Ford Motor Company has authorized your dealer to make repairs to your vehicle following the instructions accompanying each applicable customer satisfaction program(s). Any required repairs will be made free of charge (parts and labor) under the terms of this program(s).

Any applicable program(s) related to this notification will be in effect until September 30, 2024 regardless of mileage. Coverage is automatically transferred to subsequent owners.

How long will it take? The time required to repair your vehicle will vary depending on the program(s) open on your vehicle.

What should you do? Please call your dealer without delay to determine the applicable customer satisfaction program(s) on your vehicle and to schedule a service appointment for the repairs. Provide the dealer with your VIN, which is printed near your name at the beginning of this letter, to inquire about the open program(s).
If you do not already have a servicing dealer, you can access [ford.com/support](https://www.ford.com/support) for dealer addresses, maps, and driving instructions.
Ford Motor Company wants you to have these service actions completed on your vehicle. The vehicle owner is responsible for making arrangements to have the work completed. Ford Motor Company can deny coverage for any vehicle damage that may result from the failure to have the actions performed on a timely basis. Therefore, please have the service actions performed as soon as possible.
NOTE: You can receive information about Recalls and Customer Satisfaction Program(s) through our FordPass App. The app can be downloaded through the App Store or Google Play. In addition, there are other features such as reserving parking in certain locations and controlling certain functions on your vehicle (lock or unlock doors, remote start) if it is equipped to allow control.

Do you need a rental vehicle?

If your dealer determines that the repairs will require your vehicle be kept overnight, your dealer may provide a rental vehicle for your personal transportation at no charge (except for fuel, insurance, and tax) while your vehicle is at the dealership for repairs. Please see your dealer for guidelines and limitations.

What if you no longer own this vehicle?

If you no longer own this vehicle and have an address for the current owner, please forward this letter to the new owner.

You received this notice because our records, which are based primarily on state registration and title data, indicate that you are the current owner.

Can we assist you further?

If you have difficulties getting your vehicle repaired promptly and without charge, please contact your dealership's Service Manager for assistance.

RETAIL OWNERS: If you have questions or concerns, please contact our **Ford Customer Relationship Center at 1-866-436-7332** and one of our representatives will be happy to assist you. If you wish to contact us through the Internet, our address is ford.com/support.

For the hearing impaired call 1-800-232-5952 (TDD). Representatives are available Monday through Friday: 8:00 AM – 8:00 PM (Eastern Time).

FLEET OWNERS: If you have questions or concerns, please contact our **Ford Pro Contact Center at 1-800-34-FLEET**, choose Option #1, and one of our representatives will be happy to assist you. If you wish to contact us through the Internet, our address is fleet.ford.com.

Representatives are available Monday through Friday: 7:00 AM – 11:00 PM and Saturday 7:00 AM – 5:00 PM (Eastern Time).

Thank you for your attention to this important matter.

Ford Customer Service Division

23B19

MOBILE REPAIR / VEHICLE PICK-UP AND DELIVERY RECORD

VIN _____ received (check one):

- Mobile Repair
- Pick-up and/or delivery service

As outlined below for the 23B19 Field Service Action program.

Mobile Repair – Date: _____

OR

Pick-up – Date: _____

Delivery – Date: _____

Repair Order #

Repair Order Date

Service Manager Signature

Date

Recall 23B19













Mobile Service Repair Assessment

Assessment levels have been identified to help determine the ease of performing eligible mobile service repairs for a Field Service Action (FSA) outside of the dealership service facility.

Dealer Bulletin



Within Attachment I of the dealer bulletin a mobile service repair assessment level(s) will be provided. These assessment levels have been determined using the amount of time, equipment and labor identified to perform the intended service action.

Assessment Levels

-  - Mobile Reprogramming
-   - Light Mobile Service
-    - Enhanced Mobile Service
-     - Advanced Mobile Service
-  - Wheel and Tire Mobile Service
-  - Not a Mobile Service Repair

Description of each level that is used to determine the overall assessment.

-  – Mobile Reprogramming
 - Module Programming or similar type services
 - Minimum tools maybe required other than an **IDS/FDRS** setup
 - FDRS programming that requires internet connection (wi-fi or mobile hotspot)
 - Make sure vehicle has a charge port to ensure battery voltage is maintained during flashing of the module(s)
 - Repairs not greater than 1 hour in length (including time to wait for programming)

Note: The location will need a charging station or wall box to maintain the 12-volt battery.
-   – Light Mobile Service
 - Interior repair procedures that do not require seat, dash, or headliner removal
 - Under hood repairs that do not require large component removal
 - Exterior repairs that do not require large component/panel removal
 - Repairs may require standard hand tools (Access to a Technician starter kit or similar)

Recall 23B19

   – Enhanced Mobile Service

- **A two-person process is required anytime a procedure requires work under the vehicle**
 - Brake Inspection and Brake Repair/Replacement
 - Limited Suspension Component replacement (no alignment)
 - Under Vehicle access for limited repairs (no large component removal)
 - Vehicle Check Up - VCU
 - Pre-Delivery Inspection - PDI
 - Used Car Inspection/Presale Inspection
 - May require floor jack, jack stands, and impact tools
- Note: Wheel lock may be required.*

    – Advanced Mobile Service

- Fluid Exchange/Oil Change
- Light Repairs
- Brake Hydraulic Repairs

 – Wheel and Tire Mobile Service

- Tire Removal from Wheel
- Tire Balancing
- Tire Repair

Note: Specialized Mobile Service unit and equipment including Tire balancer and Tire Changer required.

 – Not a Mobile Service Repair

- Large component removal
- BEV Battery Replacement
- Requires a vehicle hoist – to complete the repair (more than inspection)
- Required vehicle alignment
- Requires significant vehicle disassembly
- Repairs greater than 2-3 hours
- Any repairs that require M-Time
- Includes a service procedure where the vehicle owner may be distressed about the state of their vehicle

CERTAIN 2023 MODEL YEAR F-150 RAPTOR R VEHICLES — FRONT AXLE VIBRATION BUMPER INSPECTION

SERVICE PROCEDURE

1. Position the vehicle on a hoist.
2. Locate the front differential vibration dampener between the engine undershield and engine rear undershield. See Figure 1.

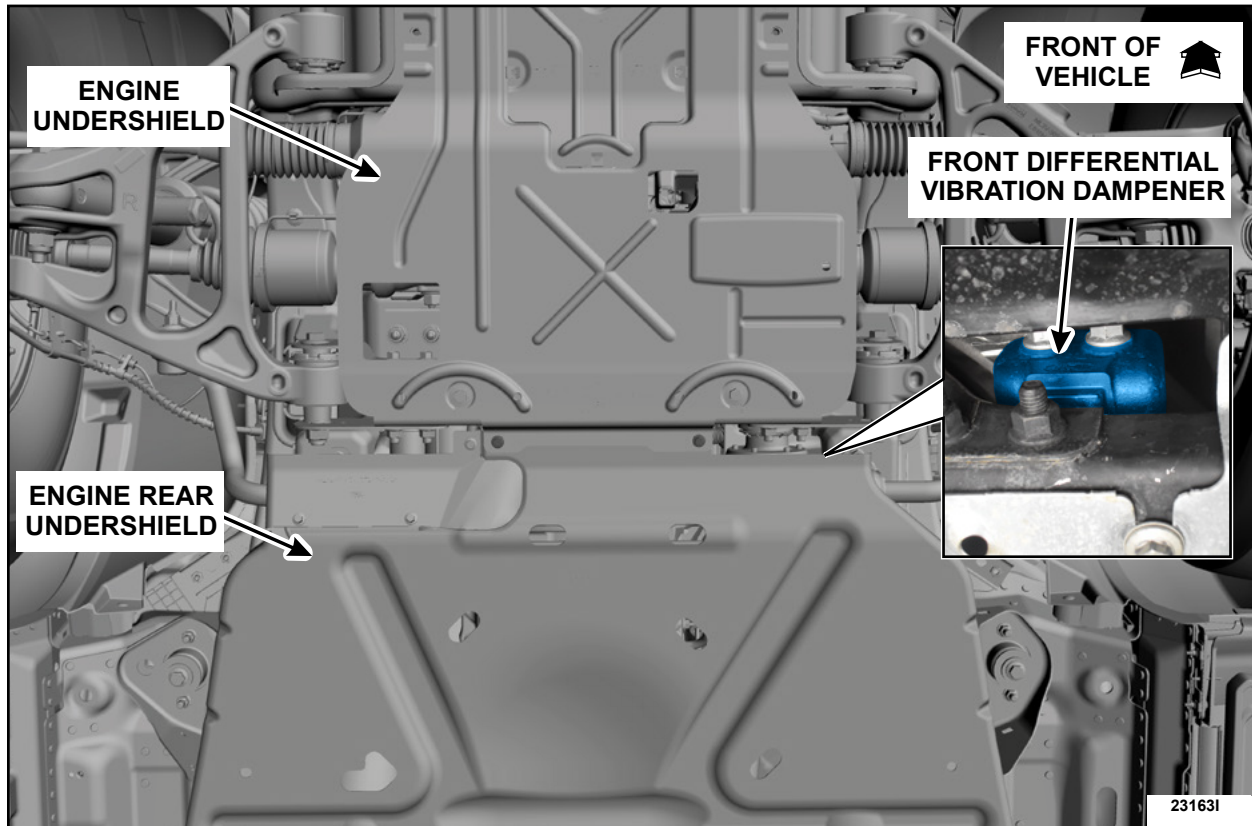

FIGURE 1



3. Inspect the front differential vibration dampener. See Figure 2. The front differential vibration dampener in the correct position will sit over top of the crossmember. In the incorrect position the front differential vibration dampener will sit out past the crossmember. Is the front differential vibration dampener installed correctly?

YES - This completes the Field Service Action (FSA)

NO - Proceed to Step 4.

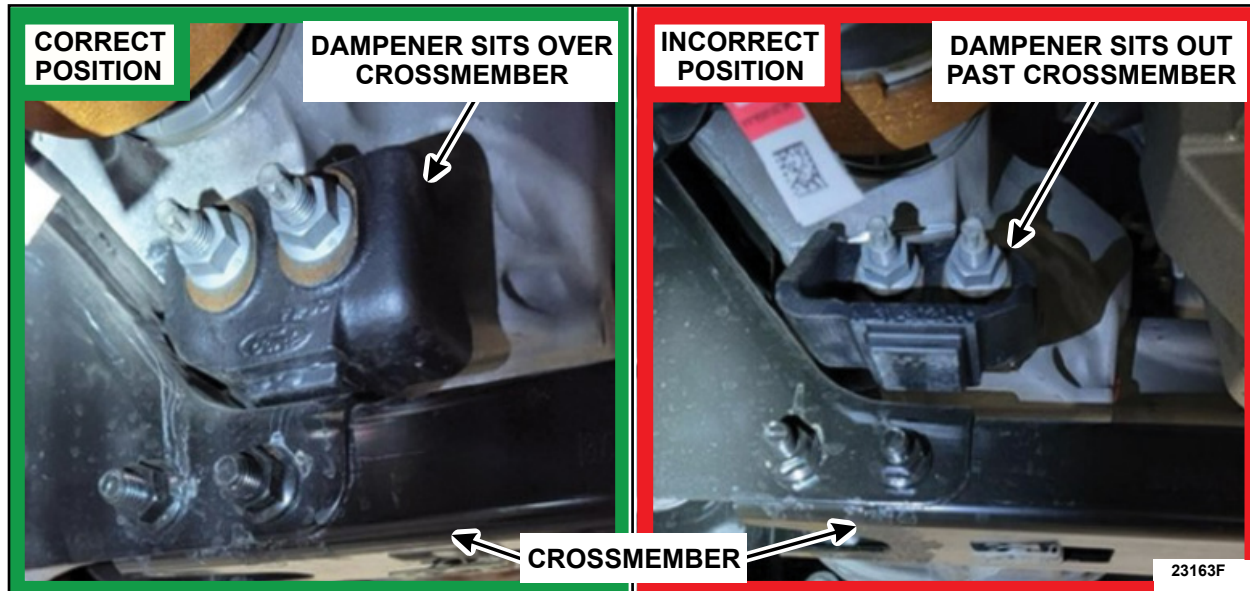

FIGURE 2



NOTICE: Using a second technician, support the engine rear undershield while the fasteners are being removed and installed. Do not allow the engine rear undershield to hang unsupported with less than 4 bolts.

4. Using the aid of another technician, remove the bolts and the underbody shield. See Figure 3.

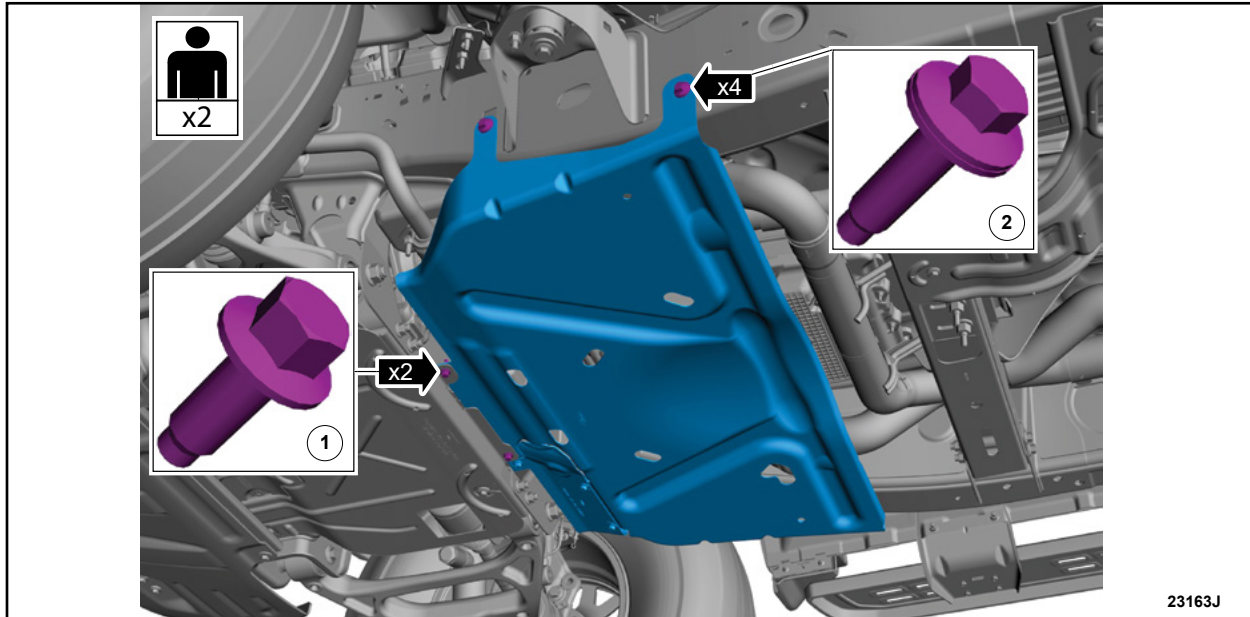

FIGURE 3

5. Remove the nuts and the front differential vibration dampener. See Figure 4.

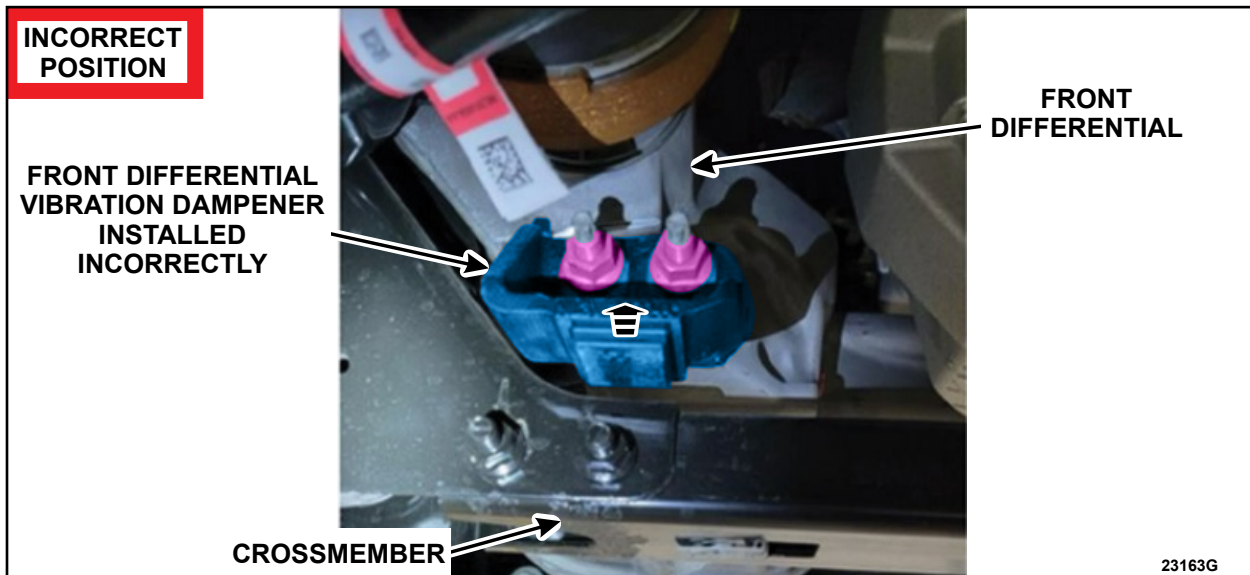

FIGURE 4



6. Flip the front differential vibration dampener to achieve the correct position and install the retainers. See Figure 5.

Torque: 76 lb.ft (103 Nm)

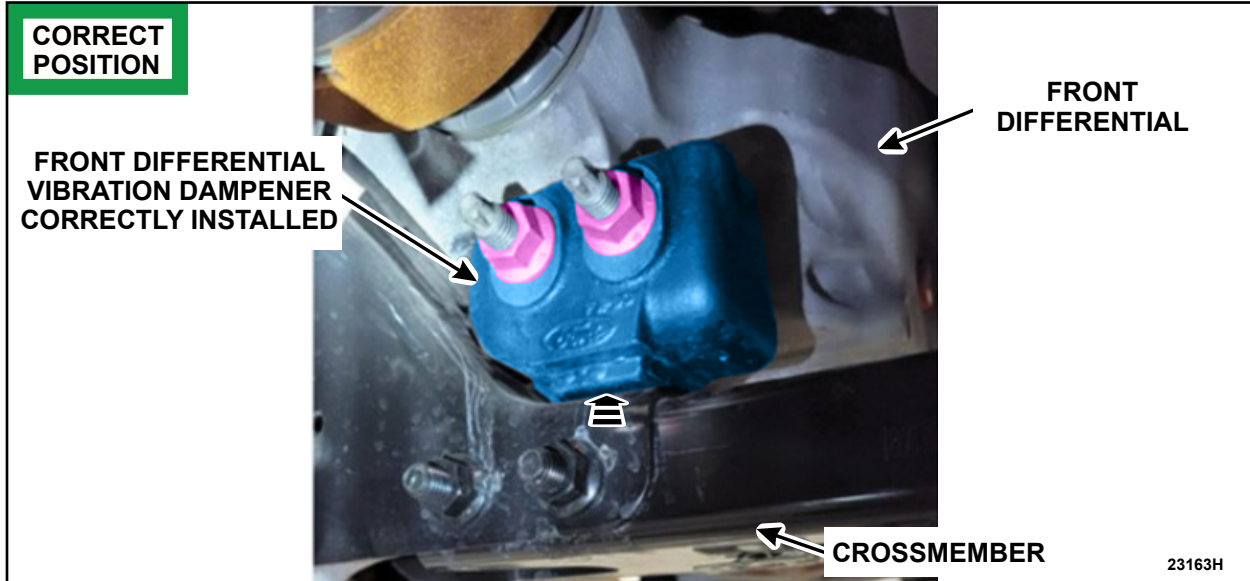

FIGURE 5

7. Using the aid of another technician, install the underbody shield and bolts. See Figure 6. This completes the FSA.

Torque 1: 22 lb.ft (30 Nm).

Torque 2: 18 lb.ft (25 Nm).

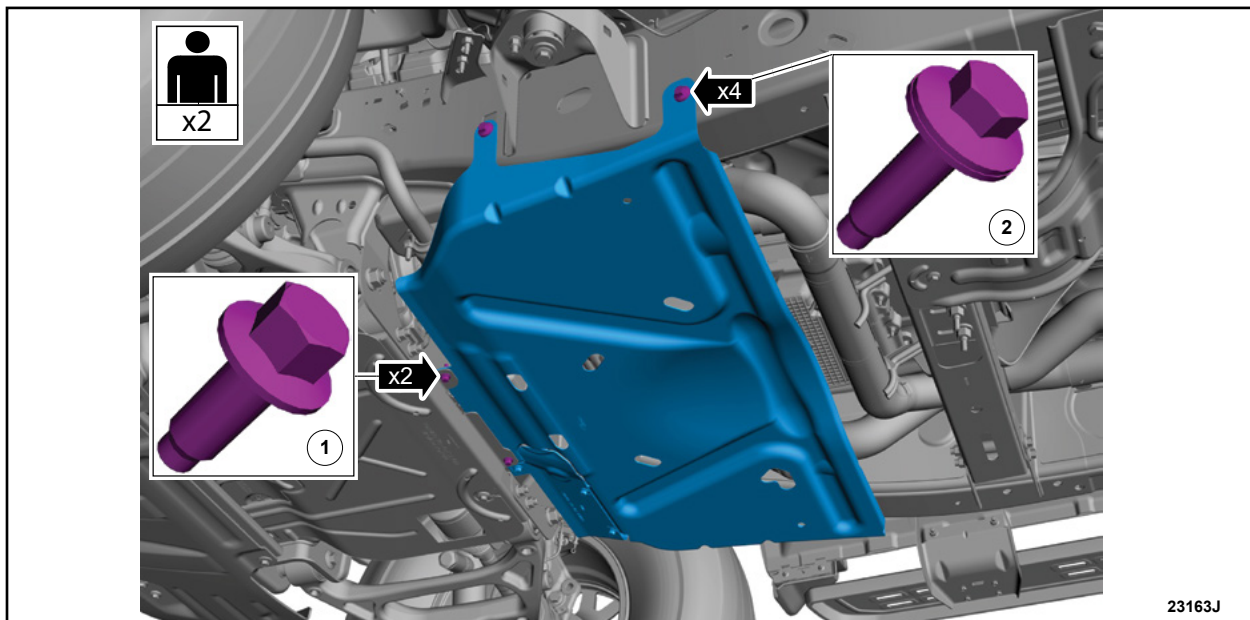

FIGURE 6

