



Stacy L. Balzer
 Operating Director
 Service Engineering Operations
 Ford Customer Service Division

Ford Motor Company
 P. O. Box 1904
 Dearborn, Michigan 48121

September 20, 2023

TO: All U.S. Ford and Lincoln Dealers

SUBJECT: Customer Satisfaction Program 23B18
 Certain 2023 Model Year 5.2L F-150 Raptor R and Mustang GT500 Vehicles
 Left and Right Cylinder Heads Rear Cup Plugs Inspect and Seal

PROGRAM

This program will be in effect through September 30, 2024. There is no mileage limit for this program.

AFFECTED VEHICLES

Vehicle	Model Year	Assembly Plant	Build Dates
F-150 Raptor R	2023	Dearborn	April 29, 2022 through March 8, 2023
Mustang GT500	2022	Flat Rock	April 29, 2022 through March 8, 2023

US population of affected vehicles: 4964. Affected vehicles are identified in OASIS and FSA VIN Lists.

Note: Some vehicles may be in the process of being repaired at the plant. Monitor OASIS before opening an RO and/or beginning a repair. Parts purchased for an FSA can be returned for credit if required. See the EXCESS STOCK RETURN details in Labor Allowances and Parts Ordering Information for more information.

REASON FOR THIS PROGRAM

In some of the affected vehicles, the engine head rear cup plugs may not have been properly installed. An improperly installed cup plug could result in an engine coolant leak which may progress to a Malfunction Indicator Light. If left unchecked, the engine may overheat and enter into a reduced performance state.

SERVICE ACTION

Dealers are to check both cylinder heads' rear cup plugs and apply Loctite 290 thread locker to seal the plugs. This service must be performed on all affected vehicles at no charge to the vehicle owner.

To maximize customer satisfaction, ensure to check OASIS for any other open customer satisfaction program(s) against this VIN, and schedule the customer in for service only after parts are available for all open programs.

OWNER NOTIFICATION MAILING SCHEDULE

Owner letters are expected to be mailed the week of October 2, 2023. Dealers should repair any affected vehicles that arrive at their dealerships, whether or not the customer has received a letter.

ATTACHMENTS

- Administrative Information
- Labor Allowances and Parts Ordering Information
- Technical Instructions
- Mobile Service Repair Assessment
- Mobile Repair/Vehicle Pickup and Delivery Record
- Owner Notification Letter

QUESTIONS & ASSISTANCE

For questions and assistance, contact the Special Service Support Center (SSSC) via the SSSC Web Contact Site. The SSSC Web Contact Site can be accessed through the Professional Technician System (PTS) website using the SSSC link listed at the bottom of the OASIS VIN report screen or listed under the SSSC tab.

Sincerely,

A handwritten signature in black ink that reads "Stacy L. Balzer". The signature is written in a cursive style with a large, stylized "S" and "B".

Stacy L. Balzer

Customer Satisfaction Program 23B18

MOBILE SERVICE REPAIR ASSESSMENT LEVEL

 - Not a Mobile Service Repair

OASIS ACTIVATION

OASIS will be activated on September 20, 2023.

FSA VIN LISTS ACTIVATION

FSA VIN Lists will be available through <https://web.fsavinlists.dealerconnection.com> on September 20, 2023. Owner names and addresses will be available by October 20, 2023.

NOTE: Your FSA VIN Lists may contain owner names and addresses obtained from motor vehicle registration records. The use of such motor vehicle registration data for any purpose other than in connection with this program is a violation of law in several states, provinces, and countries. Accordingly, you must limit the use of this listing to the follow-up necessary to complete this service action.

SOLD VEHICLES

- Owners of affected vehicles will be directed to dealers for repairs.
- Immediately contact any of your affected customers whose vehicles are not on your VIN list but are identified in OASIS. Give the customer a copy of the Owner Notification Letter (when available) and schedule a service date.
- Correct other affected vehicles identified in OASIS which are brought to your dealership.
- Dealers are to prioritize repairs of customer vehicles over repairs of new and used vehicle inventory.

STOCK VEHICLES

- Correct all affected units in your new vehicle inventory before delivery.
- Use OASIS to identify any affected vehicles in your used vehicle inventory.

BRANDED / SALVAGED TITLE VEHICLES

Affected branded / salvaged title vehicles are eligible for this service action.

OWNER REFUNDS

Refunds are not approved for this program.

RENTAL VEHICLES

Rental vehicles should not be required for this program. If you have a unique owner circumstance or multiple programs, a rental vehicle may be approved. Please contact the SSSC via the SSSC Web Contact Site.

PICK-UP AND DELIVERY- Participating Dealers

Dealers participating in the Remote Experience Program:

- Refer to EFC12071, 2023 Remote Experience Program, Pickup & Delivery (PDL) Offset section for additional details.

Customer Satisfaction Program 23B18

PICK-UP AND DELIVERY- Non-participating Dealers

Dealers not participating in the 2023 Remote Experience Program for Pick-up & Delivery are authorized to claim unique services for completing this program.

- Dealers are authorized to claim one-half labor hour per repair for vehicle pick-up & delivery services. Refer to Labor Allowances for details.
- Dealers must retain a Vehicle Pick-up & Delivery Record with the repair order documentation.

ADDITIONAL REPAIR (LABOR TIME AND/OR PARTS)

Additional repairs identified as necessary to complete the FSA should be managed as follows:

- For related damage and access time requirements, refer to the Warranty and Policy Manual / Section 6 – Ford & Lincoln Program Policies / General Information & Special Circumstances for FSAs / Related Damage.
- For vehicles within new vehicle bumper-to-bumper warranty coverage, no SSSC approval is required, although related damage must be on a separate repair line with the “Related Damage” radio button checked.
 - Ford vehicles – 3 years or 36,000 miles
- For vehicles outside new vehicle bumper-to-bumper warranty coverage, submit an Approval Request to the SSSC Web Contact Site before completing the repair.

CLAIMS PREPARATION AND SUBMISSION

- **Claim Entry:** Enter claims using Dealer Management System (DMS) or One Warranty Solution (OWS) online.
 - When entering claims:
 - Claim type 31: Field Service Action
 - Sub Code: 23B18
 - Customer Concern Code (CCC): L87 Coolant Leak
 - Condition Code (CC): 12 Improper Assembly
 - Causal Part Number: 6026, Quantity 0
 - For additional claims preparation and submission information, refer to the Recall and Customer Satisfaction Program (CSP) Repairs in the OWS User Guide.
- **Related Damage/Additional labor and/or parts:** Must be claimed as Related Damage on a separate repair line from the FSA with the same claim type and subcode as described in Claim Entry above.

IMPORTANT: Click the Related Damage Indicator radio button.

Customer Satisfaction Program 23B18

- **Pickup & Delivery:**
 - Dealers participating in the Remote Experience Program –
 - Refer to EFC12071, 2023 Remote Experience Program, Pickup & Delivery (PDL) Offset section for additional details.
 - Dealers NOT participating in the Remote Experience Program –
 - Dealers are authorized to claim one-half labor hour per repair visit for vehicle pick-up and delivery services.
 - Dealers must retain a Vehicle Pick-up and Delivery Record with the repair order documentation.
- **Provision for Locally Obtained Supplies:** Includes Loctite 290 thread locker. Submit on the same line as the repair.
 - Program Code: 23B18
 - Misc. Expense: OTHER
 - Misc. Expense: Claim up to \$5.00

Labor Allowances and Parts Ordering Information

Page 1 of 2

Customer Satisfaction Program 23B18

LABOR ALLOWANCES

Description	Labor Operation	Labor Time
Inspect and reseal both rear cylinder head cup plugs – F-150 Raptor R vehicles	23B18B	1.1 Hours
Inspect and reseal both rear cylinder head cup plugs – Mustang GT500 vehicles	23B18C	2.2 Hours
Vehicle Pick-up and Delivery Allowance: This allowance is only for <u>non-eligible</u> 2023 Remote Experience Program Dealers. NOTE: This allowance is for dealer-performed vehicle pick-up/delivery for dealership repairs only. Can only be claimed once per repair visit, regardless of outstanding FSAs repaired.	23B18PP	0.5 Hours

Order the parts below through normal order processing channels:

Part Number	Description	Order Quantity	Claim Quantity
FR3Z- 5B266-A	Exhaust collector gasket (GT500 only)	1	1
W705443-S900	Exhaust collector nuts (GT500 only)	1	2
Loctite 290	Thread locker – medium strength wicking grade	Obtain Locally	

Order your parts requirements through normal order processing channels. To guarantee the shortest delivery time, an emergency order for parts must be placed.

DEALER PRICE

For the latest prices, refer to DOES II.

EXCESS STOCK RETURN

The excess stock returned for credit must have been purchased from Ford Customer Service Division by Policy Procedure Bulletin 4000.

REPLACED FSA PARTS INSPECTION AND SIGN OFF

Effective March 1st, 2021, all parts replaced as part of an FSA repair with a repair order open date of March 1st, 2021, or later must be inspected and signed off on the repair order by a member of your dealer's fixed operations management team or an employee the task has been delegated to. If the task is to be delegated to a non-management employee, the employee needs to be someone other than the technician who completed the repair and needs to understand the importance of completing this task consistently and accurately.

- All parts replaced as part of an FSA repair should be returned to the parts department following the Warranty Parts Retention and Return Policies.
- Inspect the replaced parts to verify the FSA repair was completed.

Customer Satisfaction Program 23B18

REPLACED FSA PARTS INSPECTION AND SIGN OFF (continued)

- If the FSA repair is found to be complete, the designated employee signs the repair order line or parts return stamp area (electronic or hand signed) for the FSA repair indicating the parts were inspected and validated to have been replaced.
- After the parts have been inspected, they should be handled based on the guidance in the parts status report in the Online Warranty System (Hold, Return, CORE, Scrap, etc.). Please visit FMCDEALER > PARTS & SERVICE > WARRANTY ADMINISTRATION & WARRANTY PARTS RETURN for the latest [Immediate Scrap List](#) information.
- This process is subject to review during warranty audits for FSA repairs with a repair order open date of March 1st, 2021, or later. Any eligible FSA claims requiring parts replacement found not to have been inspected and signed off during a warranty audit will be subject to chargeback and consideration for enrollment into the Dealer Incomplete Recall Repair Process.

Note: Other approvals (electronic or handwritten) for add-on repair lines, dealer-owned vehicle repairs, and repeat repairs do not qualify as FSA parts inspection approvals. The post-repair FSA parts inspection process (electronic or handwritten) is independent of other warranty approval requirements. The approval by the designated employee implies that the FSA parts were found to be replaced and must be able to be identified on the Repair Order. If multiple FSAs require approval on a single Repair Order, each applicable occurrence will require individual post-repair approval by the designated employee.



Ford Motor Company
Ford Customer Service Division
P. O. Box 1904
Dearborn, Michigan 48121

October 2023

Customer Satisfaction Program(s): 23B17, 23B18, 23B19, 23B20, 23B25
Mr. John Sample
123 Main Street
Anywhere, USA 12345

Your Vehicle Identification Number (VIN): 12345678901234567

At Ford Motor Company, we are committed not only to building high-quality, dependable products but also to building a community of happy, satisfied customers. To demonstrate that commitment, we are providing one or more a no-charge Customer Satisfaction Program(s) for your vehicle with the VIN shown above.

Why are you receiving this notice? Your vehicle may have one or more customer satisfaction program(s) open.

What is the effect? Depending on which program(s) apply, the effect on your vehicle may include oil/coolant leaks, unwanted noise from the front end and/or unwanted noise from underneath the vehicle.
To find the specific program(s) information for your vehicle, you can check service section of your FordPass app, visit the website below, or use the QR code: <https://www.ford.com/support/recalls>



What will Ford and your dealer do? In the interest of customer satisfaction, Ford Motor Company has authorized your dealer to make repairs to your vehicle following the instructions accompanying each applicable customer satisfaction program(s). Any required repairs will be made free of charge (parts and labor) under the terms of this program(s).

Any applicable program(s) related to this notification will be in effect until September 30, 2024 regardless of mileage. Coverage is automatically transferred to subsequent owners.

How long will it take? The time required to repair your vehicle will vary depending on the program(s) open on your vehicle.

What should you do? Please call your dealer without delay to determine the applicable customer satisfaction program(s) on your vehicle and to schedule a service appointment for the repairs. Provide the dealer with your VIN, which is printed near your name at the beginning of this letter, to inquire about the open program(s).
If you do not already have a servicing dealer, you can access [ford.com/support](https://www.ford.com/support) for dealer addresses, maps, and driving instructions.
Ford Motor Company wants you to have these service actions completed on your vehicle. The vehicle owner is responsible for making arrangements to have the work completed. Ford Motor Company can deny coverage for any vehicle damage that may result from the failure to have the actions performed on a timely basis. Therefore, please have the service actions performed as soon as possible.
NOTE: You can receive information about Recalls and Customer Satisfaction Program(s) through our FordPass App. The app can be downloaded through the App Store or Google Play. In addition, there are other features such as reserving parking in certain locations and controlling certain functions on your vehicle (lock or unlock doors, remote start) if it is equipped to allow control.

Do you need a rental vehicle?

If your dealer determines that the repairs will require your vehicle be kept overnight, your dealer may provide a rental vehicle for your personal transportation at no charge (except for fuel, insurance, and tax) while your vehicle is at the dealership for repairs. Please see your dealer for guidelines and limitations.

What if you no longer own this vehicle?

If you no longer own this vehicle and have an address for the current owner, please forward this letter to the new owner.

You received this notice because our records, which are based primarily on state registration and title data, indicate that you are the current owner.

Can we assist you further?

If you have difficulties getting your vehicle repaired promptly and without charge, please contact your dealership's Service Manager for assistance.

RETAIL OWNERS: If you have questions or concerns, please contact our **Ford Customer Relationship Center at 1-866-436-7332** and one of our representatives will be happy to assist you. If you wish to contact us through the Internet, our address is ford.com/support.

For the hearing impaired call 1-800-232-5952 (TDD). Representatives are available Monday through Friday: 8:00 AM – 8:00 PM (Eastern Time).

FLEET OWNERS: If you have questions or concerns, please contact our **Ford Pro Contact Center at 1-800-34-FLEET**, choose Option #1, and one of our representatives will be happy to assist you. If you wish to contact us through the Internet, our address is fleet.ford.com.

Representatives are available Monday through Friday: 7:00 AM – 11:00 PM and Saturday 7:00 AM – 5:00 PM (Eastern Time).

Thank you for your attention to this important matter.

Ford Customer Service Division

CERTAIN 2023 MODEL YEAR 5.2L F-150 RAPTOR R AND MUSTANG GT 500 VEHICLES — LEFT AND RIGHT CYLINDER HEADS REAR CUP PLUGS INSPECT AND SEAL

NOTE: For Mustang GT 500 service procedure see below.

NOTE: For F-150 Raptor R service procedure proceed to Page 6.

MUSTANG GT 500 SERVICE PROCEDURE

1. Remove the strut tower cross brace. Follow the Workshop Manual (WSM) procedures in Section 501-02.
2. Remove the battery tray. Follow the WSM procedures in Section 414-01.
3. Remove the fasteners and the battery heat shield. See Figure 1.

•Torque: 80 lb.in (9 Nm)

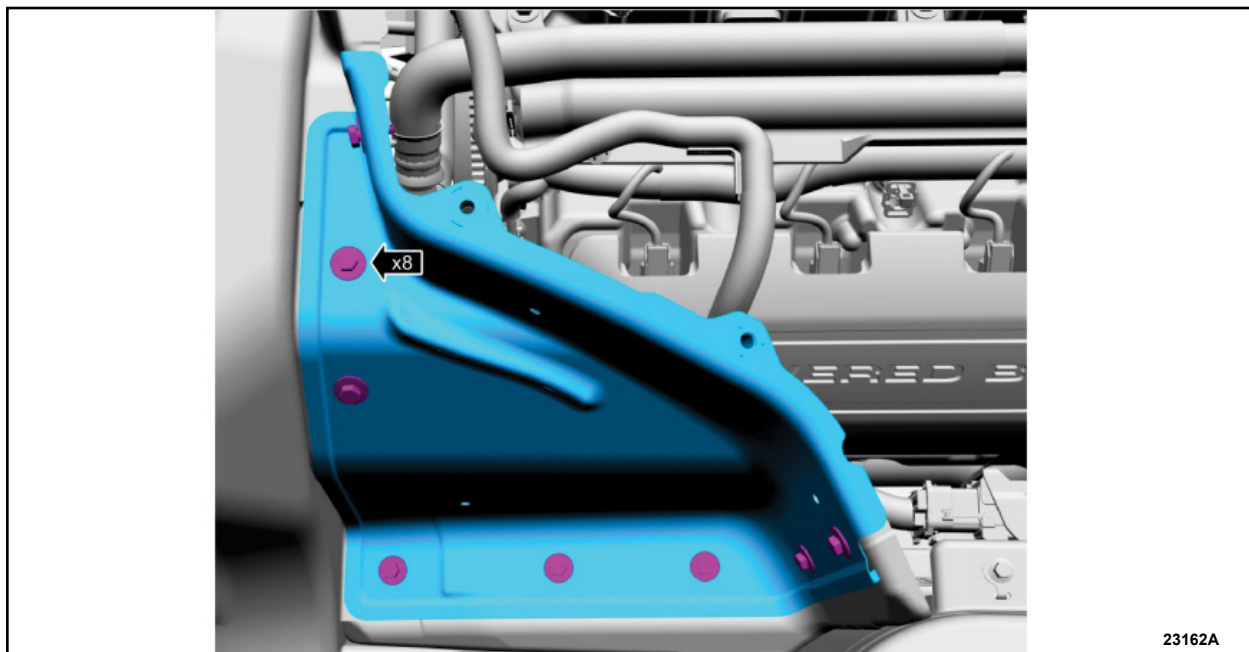

FIGURE 1



4. Position aside the heat shield covering the crankshaft position sensor electrical connector.
See Figure 2.

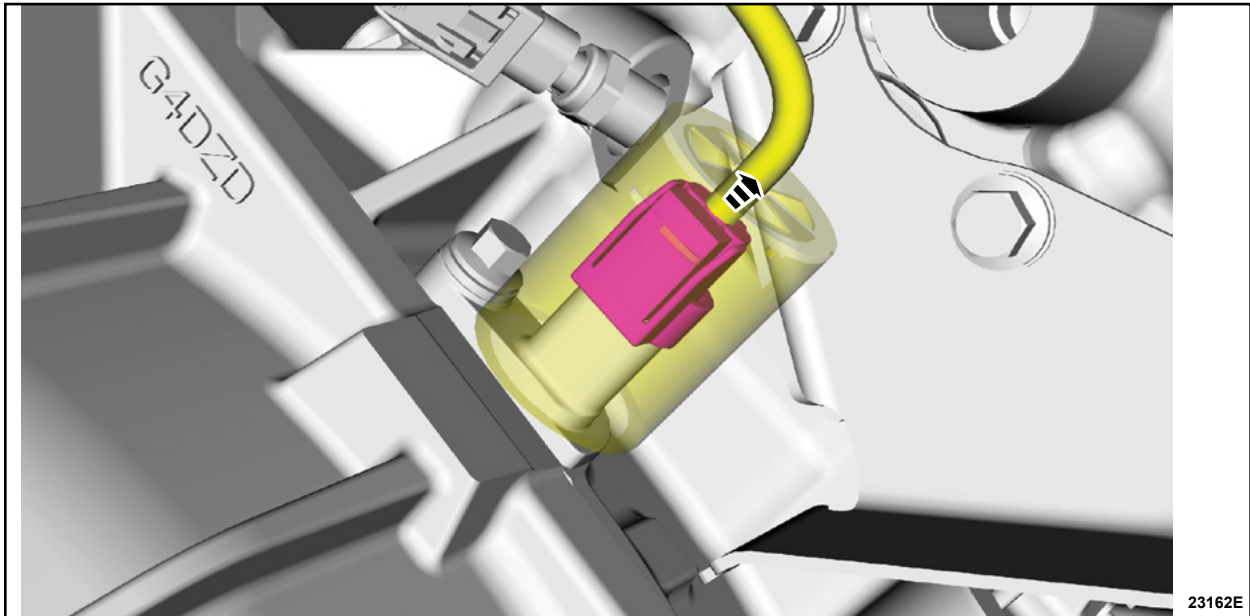

FIGURE 2

5. Remove the right hand (RH) heat shield and disconnect the exhaust camshaft position sensor electrical connector. See Figure 3.

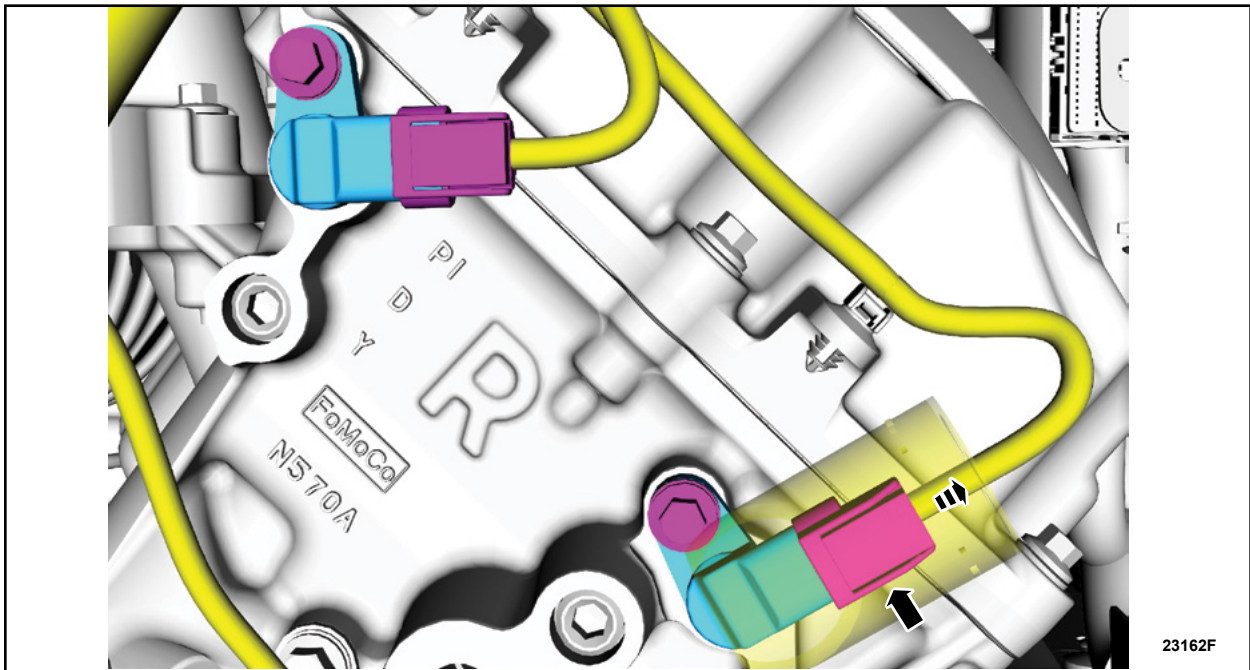

FIGURE 3



6. Remove the fasteners and the heat shield to gain full access to the RH engine cup plug.
See Figure 4.

- Torque Stage 1: 89 lb.in (10 Nm)
- Torque Stage 2: 45 degrees

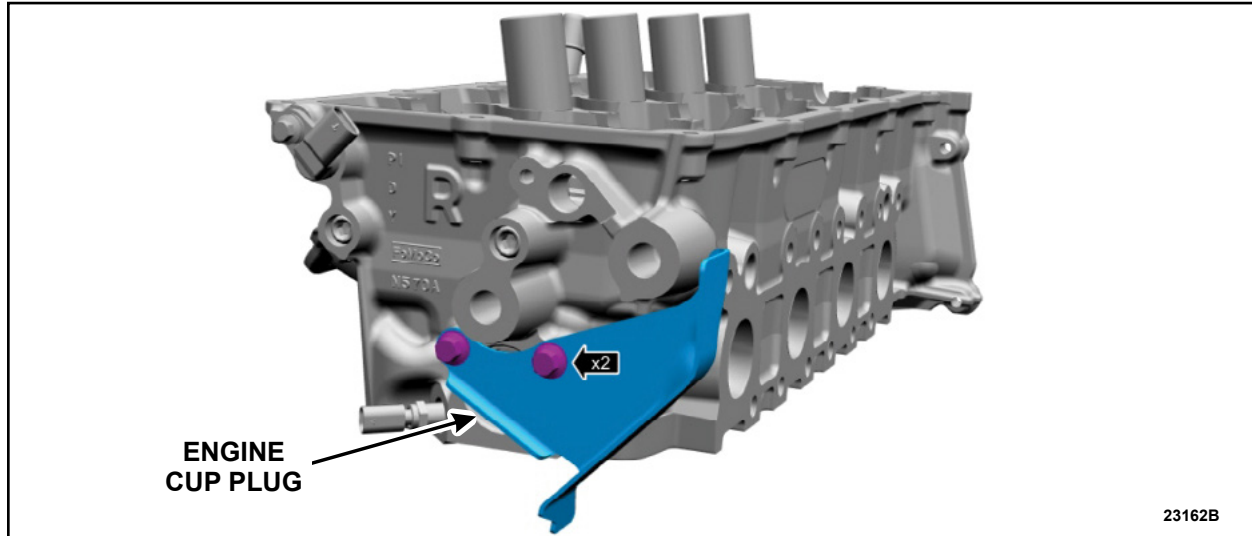

FIGURE 4

7. Spray the engine cup plug and surrounding area with brake cleaner to remove any debris that may be present.
8. Blow the area off with compressed air.
9. Repeat steps 7 and 8 a second time.
10. Clean the engine cup plug further if necessary.
11. Fully saturate a large swab with Loctite 290. See Figure 5.



FIGURE 5



12. Using the fully saturated swab, apply a generous amount of Loctite 290 around the full perimeter of the engine cup plug so that it wicks around the sealing surface completely. See Figure 6.

NOTE: It may be necessary to attach the swab to an extension to reach the cup plug. See Figure 6.

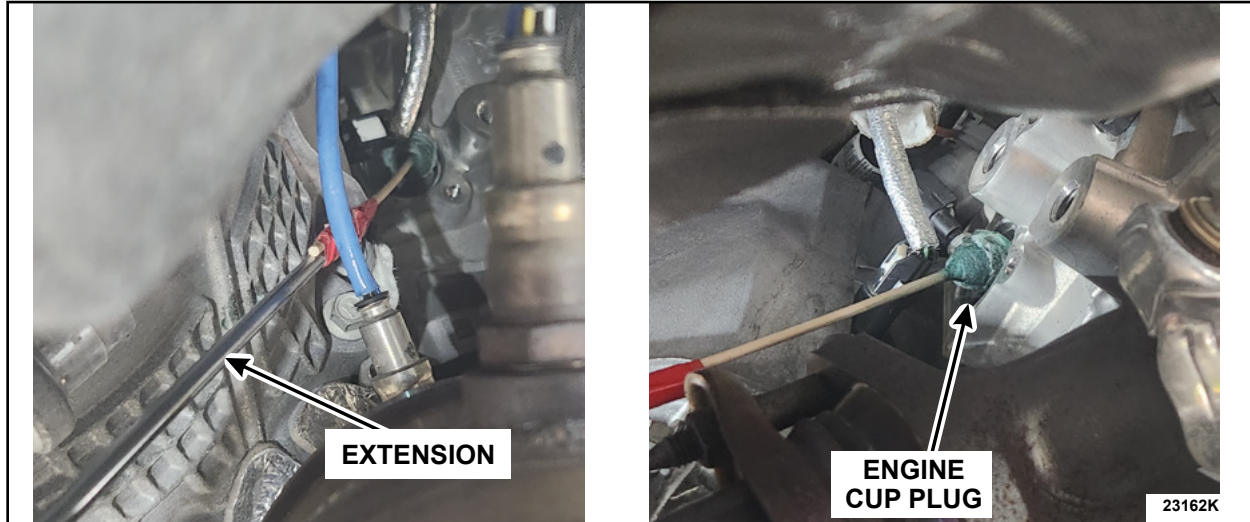

FIGURE 6

13. Clean off any excess Loctite 290 that may be dripping down from the sealing surface.

14. Remove the left hand (LH) catalytic converter. Follow the WSM procedures in Section 309-00C.

15. Remove the fasteners and the exhaust heat shield. See Figure 7.

• Torque: 5.9 lb.ft (8 Nm)

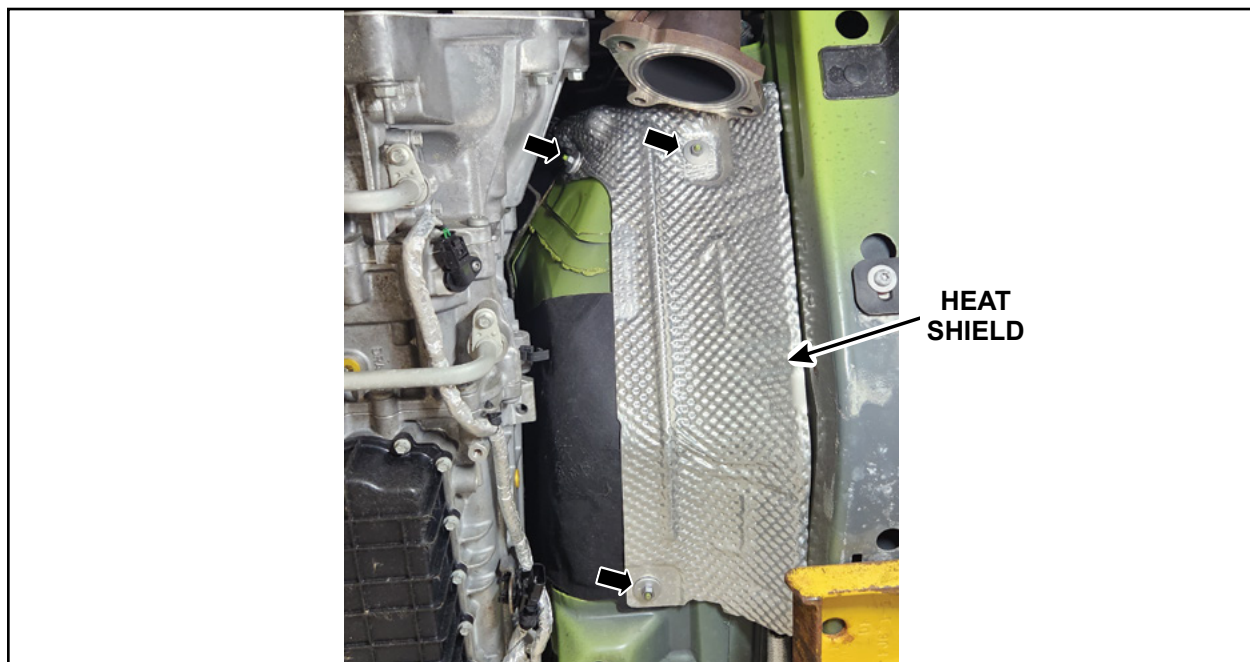

FIGURE 7



16. Remove the ground wire from the heat shield. See Figure 8.



FIGURE 8

17. Remove the fasteners and the heat shield to gain full access to the LH engine cup plug.
See Figure 9.

- Torque Stage 1: 89 lb.in (10 Nm)
- Torque Stage 2: 45 degrees

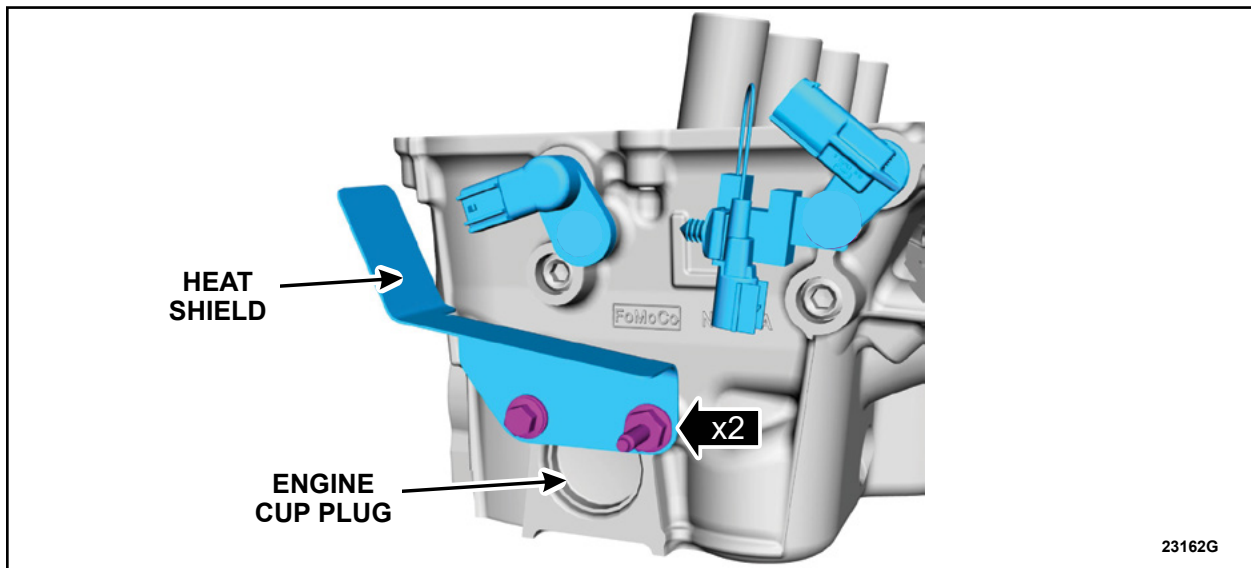

FIGURE 9

18. Repeat steps 7 through 13 on the LH engine cup plug.

19. Reassemble the LH side of the vehicle by reversing steps 14 through 17.

20. Reassemble the RH side of the vehicle by reversing steps 1 through 6.



F-150 RAPTOR R SERVICE PROCEDURE

1. Remove the bolts and the engine front undershield. See Figure 10.

- Torque 1: 35 lb.ft (48 Nm)
- Torque 2: 41 lb.ft (55 Nm)

NOTE: This step requires the aid of another technician.

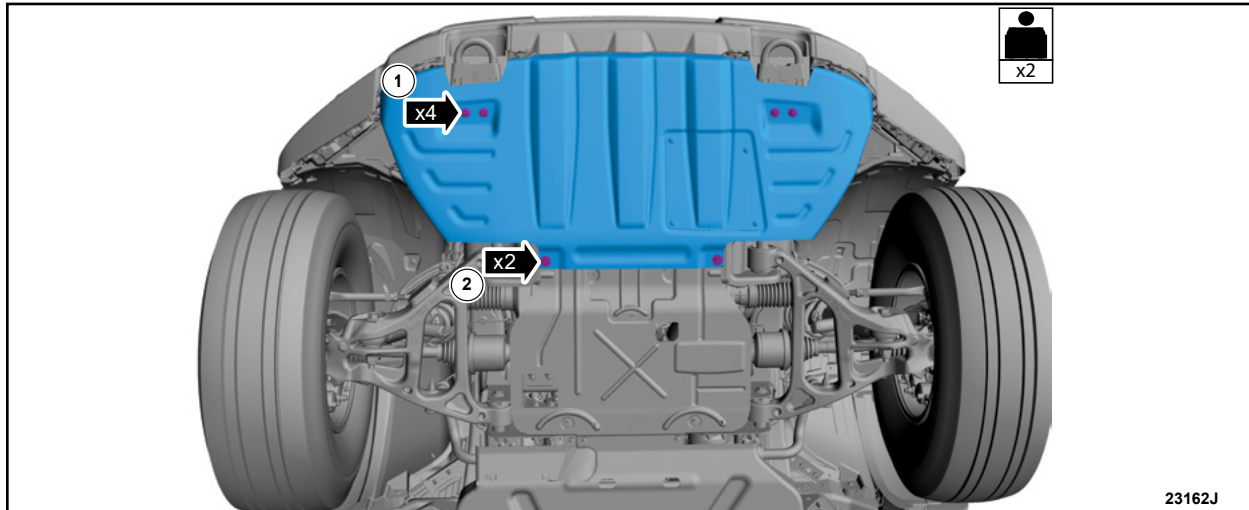

FIGURE 10

2. Remove the fender splash shield on both sides. Follow the Workshop Manual (WSM) procedures in Section 501-02.

3. Remove the right hand (RH) heat shield and disconnect the exhaust camshaft position sensor electrical connector. See Figure 11.

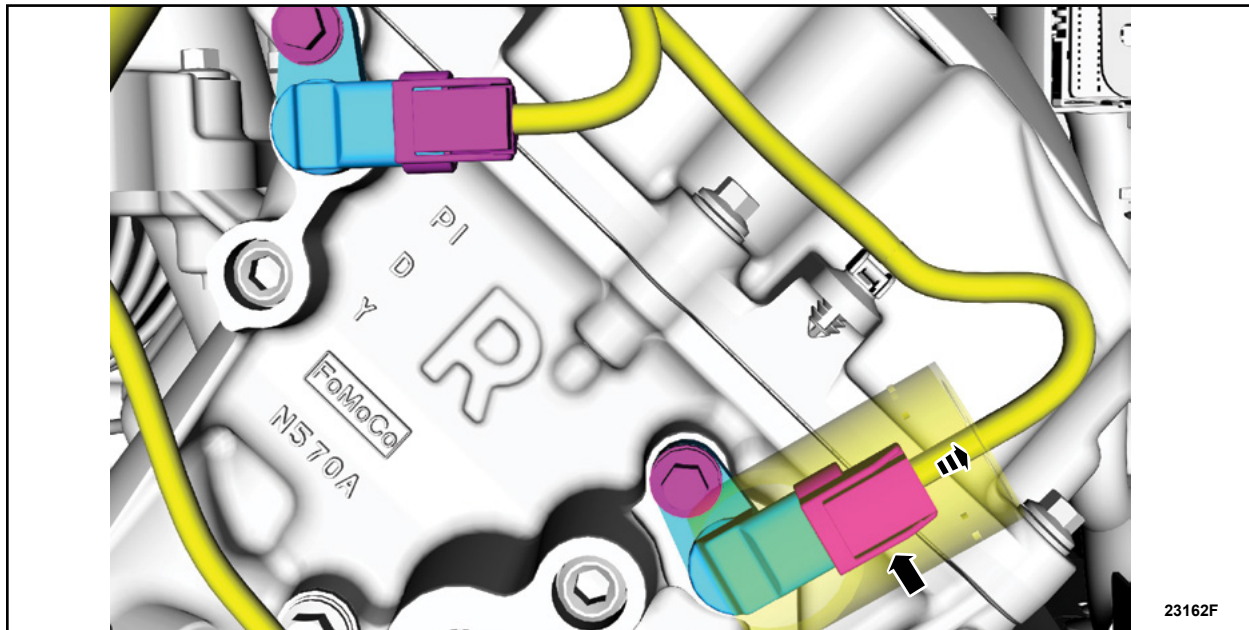

FIGURE 11



4. Remove the fasteners and the heat shield to gain full access to the RH engine cup plug.
See Figure 12.

- Torque Stage 1: 89 lb.in (10 Nm)
- Torque Stage 2: 45 degrees

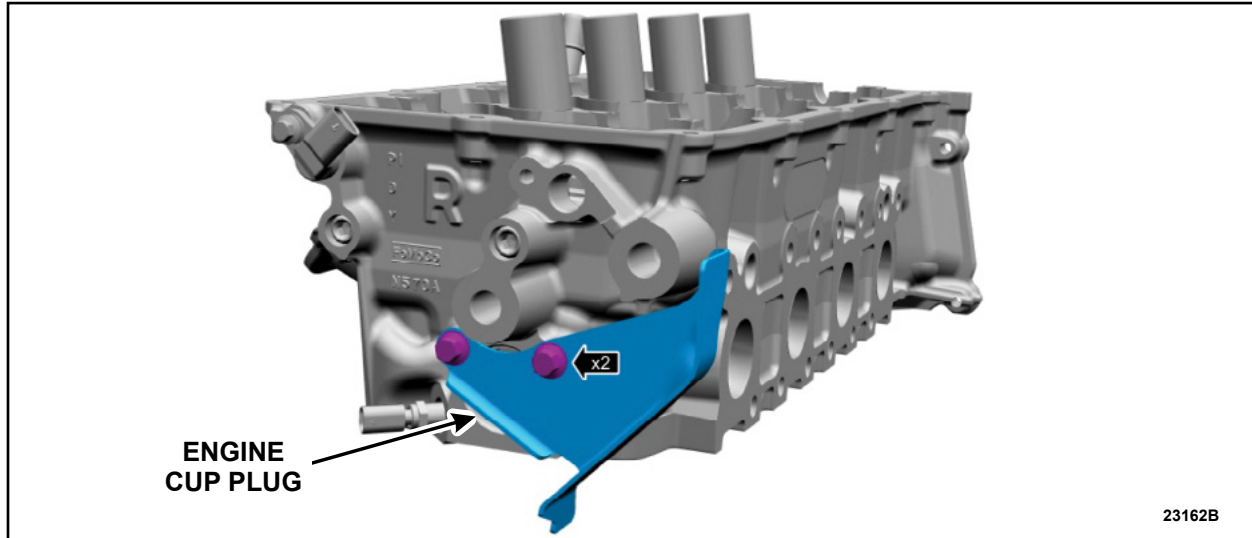

FIGURE 12

5. Remove the fasteners and the heat shield to gain full access to the left hand (LH) engine cup plug.
See Figure 13.

- Torque Stage 1: 89 lb.in (10 Nm)
- Torque Stage 2: 45 degrees

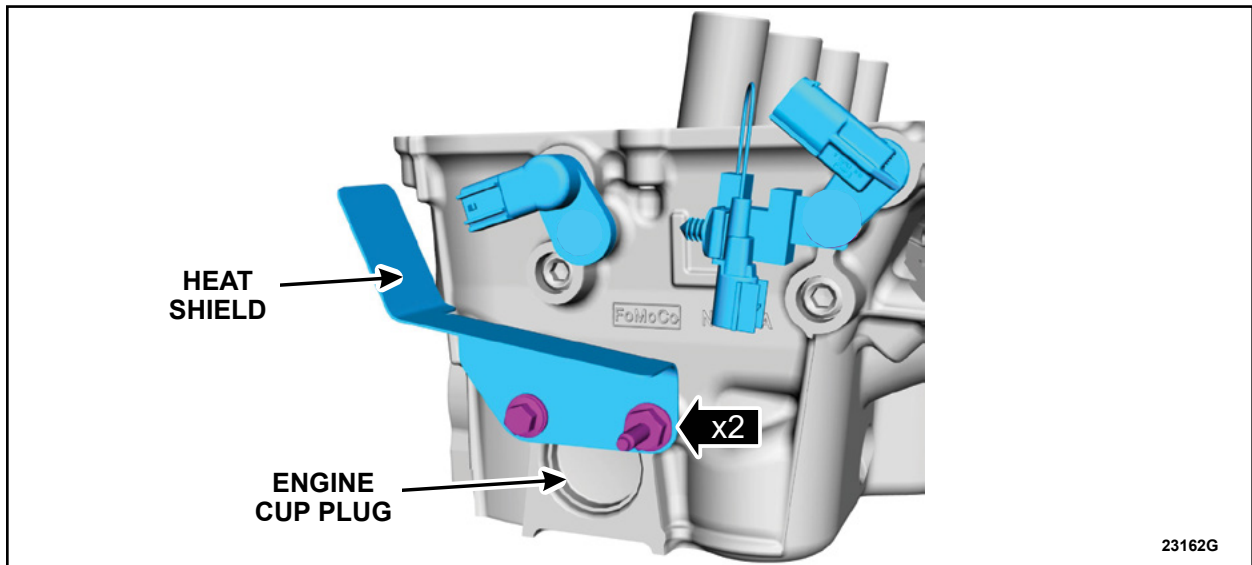

FIGURE 13



6. Spray the RH engine cup plug and surrounding area with brake cleaner to remove any debris that may be present.
7. Blow the area off with compressed air.
8. Repeat steps 6 and 7 a second time.
9. Clean the engine cup plug further if necessary.
10. Repeat steps 6 through 9 on the LH engine cup plug.
11. Fully saturate a large swab with Loctite 290. See Figure 14.



FIGURE 14

12. Using the fully saturated swab, apply a generous amount of Loctite 290 around the full perimeter of both engine cup plugs so that it wicks around the sealing surface completely. See Figure 15.

NOTE: It may be necessary to attach the swab to an extension to reach the cup plug. See Figure 15.

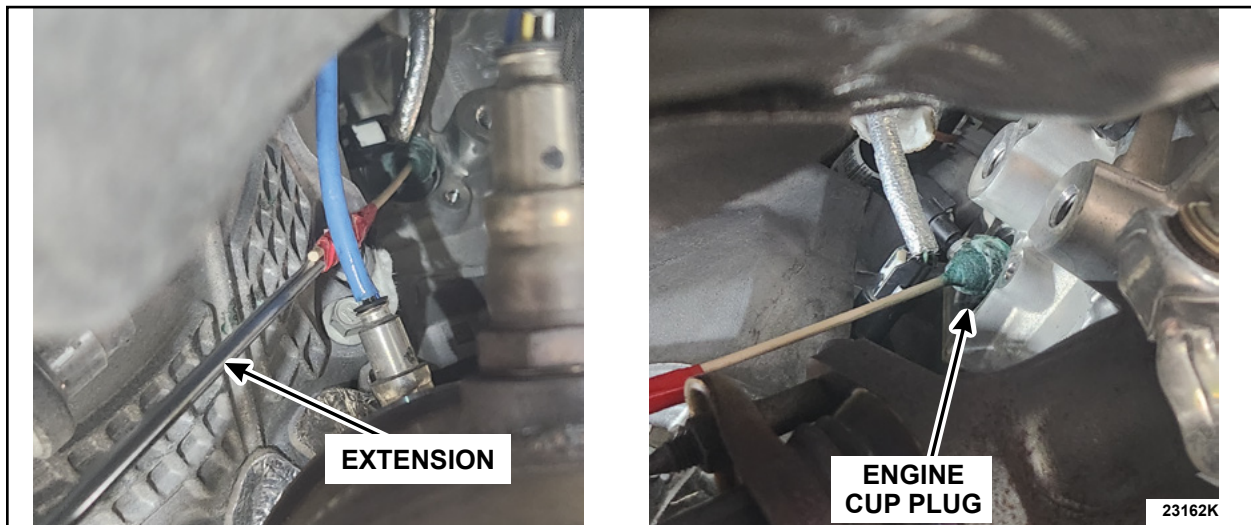

FIGURE 15



13. Clean off any excess Loctite 290 that may be dripping down from the sealing surface on either side.
14. Reassemble the vehicle by reversing steps 1 through 5.



23B18

MOBILE REPAIR / VEHICLE PICK-UP AND DELIVERY RECORD

VIN _____ received (check one):

- Mobile Repair
- Pick-up and/or delivery service

As outlined below for the 23B18 customer satisfaction program.

Mobile Repair – Date: _____

OR

Pick-up – Date: _____

Delivery – Date: _____

Repair Order #

Repair Order Date

Service Manager Signature

Date

Recall 23B18













Mobile Service Repair Assessment

Assessment levels have been identified to help determine the ease of performing eligible mobile service repairs for a Field Service Action (FSA) outside of the dealership service facility.

Dealer Bulletin



Within Attachment I of the dealer bulletin a mobile service repair assessment level(s) will be provided. These assessment levels have been determined using the amount of time, equipment and labor identified to perform the intended service action.

Assessment Levels

-  - Mobile Reprogramming
-   - Light Mobile Service
-    - Enhanced Mobile Service
-     - Advanced Mobile Service
-  - Wheel and Tire Mobile Service
-  - Not a Mobile Service Repair

Description of each level that is used to determine the overall assessment.

-  – Mobile Reprogramming
 - Module Programming or similar type services
 - Minimum tools maybe required other than an **IDS/FDRS** setup
 - FDRS programming that requires internet connection (wi-fi or mobile hotspot)
 - Make sure vehicle has a charge port to ensure battery voltage is maintained during flashing of the module(s)
 - Repairs not greater than 1 hour in length (including time to wait for programming)

Note: The location will need a charging station or wall box to maintain the 12-volt battery.
-   – Light Mobile Service
 - Interior repair procedures that do not require seat, dash, or headliner removal
 - Under hood repairs that do not require large component removal
 - Exterior repairs that do not require large component/panel removal
 - Repairs may require standard hand tools (Access to a Technician starter kit or similar)

Recall 23B18

   – Enhanced Mobile Service

- ***A two-person process is required anytime a procedure requires work under the vehicle***
 - Brake Inspection and Brake Repair/Replacement
 - Limited Suspension Component replacement (no alignment)
 - Under Vehicle access for limited repairs (no large component removal)
 - Vehicle Check Up - VCU
 - Pre-Delivery Inspection - PDI
 - Used Car Inspection/Presale Inspection
 - May require floor jack, jack stands, and impact tools
- Note: Wheel lock may be required.*

    – Advanced Mobile Service

- Fluid Exchange/Oil Change
- Light Repairs
- Brake Hydraulic Repairs

 – Wheel and Tire Mobile Service

- Tire Removal from Wheel
- Tire Balancing
- Tire Repair

Note: Specialized Mobile Service unit and equipment including Tire balancer and Tire Changer required.

 – Not a Mobile Service Repair

- Large component removal
- BEV Battery Replacement
- Requires a vehicle hoist – to complete the repair (more than inspection)
- Required vehicle alignment
- Requires significant vehicle disassembly
- Repairs greater than 2-3 hours
- Any repairs that require M-Time
- Includes a service procedure where the vehicle owner may be distressed about the state of their vehicle