

- ATTENTION:**
- GENERAL MANAGER
 - PARTS MANAGER
 - CLAIMS PERSONNEL
 - SERVICE MANAGER

IMPORTANT - All Service Personnel Should Read and Initial in the boxes provided, right.

© 2014 Subaru of America, Inc. All rights reserved.



QUALITY DRIVEN® SERVICE

PRODUCT CAMPAIGN BULLETIN

APPLICABILITY: 2009-2012MY Subaru Forester
SUBJECT: Rear Seat Center Seatbelt

NUMBER: WQA-37
DATE: March 2012

REVISED: 10/29/14

Subaru has prepared a new repair kit for this campaign. As a result, there are two separate WQA-37 Seatbelt Kits available, Kit 1 or Kit 2. Only one kit is needed for each vehicle and either one is acceptable for completing this recall. **Kit 1 will be reintroduced when inventory of Kit 2 has been depleted.** This bulletin has been revised to include repair instructions for both kits. The installation instructions for Kit 2 begin on pg. 14.

INTRODUCTION

Subaru has determined that certain 2009 through 2012 model year Forester vehicles have been manufactured with a rear seat center seatbelt that does not comply with the Federal Motor Vehicle Safety Standard requirement for securing a child restraint system (CRS) also known as a “child safety seat”.

The rear center seatbelt may not adequately secure certain CRSs that require a short belt routing configuration for attachment. This seatbelt contains an Automatic Locking Retractor that may not lock as intended when such a configuration is used, preventing a tight and secure installation of the CRS. If the CRS is not properly secured, the CRS may not provide the protection it was designed to provide, and the child occupying the CRS may be at an increased risk of injury in the event of a crash.

This recall will involve updating the rear seat center seatbelt on all affected vehicles.

AFFECTED VEHICLES

2009-2012 Model Year Forester: **2012 model vehicles will have a production update beginning March 14, 2012. Vehicles produced on or after this date are not affected by this recall campaign.**

Affected VINs are contained in the following range.

Model		From	To
Forester	2009MY	JF2SH6*6*9*700001	JF2SH6*6*9*797855
	2010MY	JF2SH6*C*A*700001	JF2SH6*C*A*918317
	2011MY	JF2SH**C*B*700001	JF2SH**C*B*783898
	2012MY	JF2SH**C*C*400002	JF2SH**C*C*457256

* Various Characters may occupy this position

Recall coverage for all potentially affected vehicles must be confirmed by using Vehicle Coverage Inquiry in Subarunet.

Continued...

OWNER NOTIFICATION

There will be two owner notification letters sent.

The first owner notification letter was mailed on or about March 26, 2012. The letter explains the condition associated with the rear seat center seatbelt and advises vehicle owners that they will be notified by a second letter when repair parts become available.

The second owner notification letter will be sent when an adequate supply of replacement parts are available. It is anticipated that letters will be mailed according to the following schedule.

2012MY	Beginning on or about 5/1/12
2011MY	Beginning on or about 8/1/12
2010MY	Beginning on or about 10/1/12
2009MY	Beginning on or about 1/1/13

A copy of both owner notification letters is included at the end of this bulletin.

In addition to notification by mail, vehicle owners with a valid email address will be notified electronically on the same date letters are mailed.

DEALER PROGRAM RESPONSIBILITY

Dealers are to promptly perform the applicable service procedures defined in this bulletin to correct all affected vehicles in their inventory (new, used, demo & SSLP). Additionally, whenever a vehicle subject to this recall is taken into dealer new or used inventory, or in the dealership for service, necessary steps should be taken to ensure the recall correction has been made before selling or releasing the vehicle.

New, used, demo or SSLP vehicles listed in a recall/campaign that are in dealer stock must be:

- Immediately identified.
- Tagged or otherwise marked to prevent their delivery or use prior to inspection and/or repair.
- Repaired in accordance with the repair procedures outlined in this Product Campaign Bulletin.

Please be advised that it is a violation of Federal law for a dealer to deliver a new motor vehicle covered by a recall under a sale or lease until the defect is remedied. Therefore, any Authorized Subaru Dealer failing to perform the applicable service procedures as defined in this bulletin to correct all affected vehicles in their inventory (new, used, demo & SSLP) prior to the vehicle being placed in service may be subject to civil penalties of up to \$6,000 per violation (i.e., for each vehicle), as provided in 49 CFR §578.6 and will also be in breach of the Subaru Dealer Agreement.

Continued...

PARTS INFORMATION

There are two separate WQA37 Seatbelt Kits available, Kit 1 or Kit 2. **Only one kit is needed for each vehicle and either one is acceptable for completing this recall.** The part numbers are listed in the following chart. **Kit 1 will be reintroduced when inventory of Kit 2 has been depleted.**

Since each kit has specific repair instructions, please be sure to follow the instructions found in the repair section of this bulletin for the kit being used.

Based on the interior color, identify the actual part number needed in the chart below.

Name	Description	Part Number	Color
WQA37 Seatbelt Kit	Kit 1	64665SC030AP	Gray
		64665SC030AR	Black
	Kit 2	64665SC040AP	Gray
		64665SC040AR	Black

The following additional parts may also be needed in some instances where the clips are compromised during the repair process.

Part Number	Name
94482FC001LO	Seatbelt Cap – No Sunroof
94482FC501LO	Seatbelt Cap – W/Sunroof
64396KA010	Hook Rear Seat Cushion

MATERIALS NEEDED FOR INSTALLATION OF KIT 1 ONLY

It will be necessary to make two headliner supports using the following materials.

Diagrams can be found on pages 17~18.

2-welding rods 3mm (1/8 in.) in diameter

Vinyl tape

Clean shop rags

Continued...

SERVICE PROCEDURE

There are two separate WQA37 Seatbelt Kits available, Kit 1 or Kit 2. **Only one kit is needed for each vehicle and either one is acceptable for completing this recall.** The applicable part numbers are listed in the chart found on page 3.

The repair procedure will consist of replacing the rear center seating position seatbelt buckles and, when installing Kit 1, the rear center seating position retractable shoulder belt.

In preparation for installing Kit 1 only, prepare two headliner supports, one of each design using the materials listed above and the diagrams found on pages 31-32.

INSTALLATION INSTRUCTIONS FOR KIT 1

Note: Make sure to note the orientation of the seatbelt buckle prior to removal.

Before beginning, ensure your clothing and hands are free from dirt and grease.

Find a clear and clean area to lay removed rear seat cushion to avoid getting dirt on or damaging it.

1. Record preset radio stations.
2. Turn ignition switch to OFF. Disconnect the ground cable from battery, and wait for 60 seconds or more before starting work.
3. (Models with seat table). Flip open the seat table of the rear seat cushion and remove trim cover. Disconnect the table light (white) wiring connector. **Caution:** Do not disconnect the satellite safing sensor wiring connector. Remove the 4 (10mm) bolts.

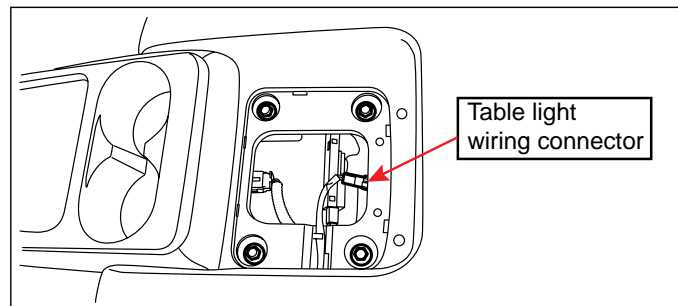

Seat Anchor locations depending upon applicability (with or without seat table).

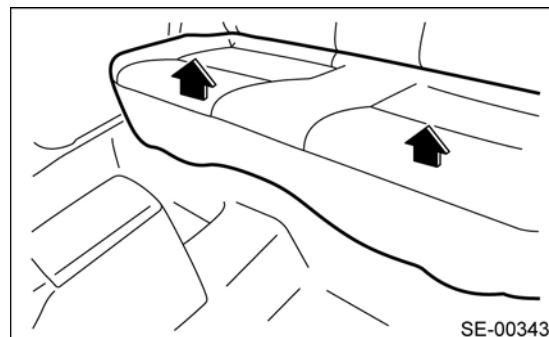
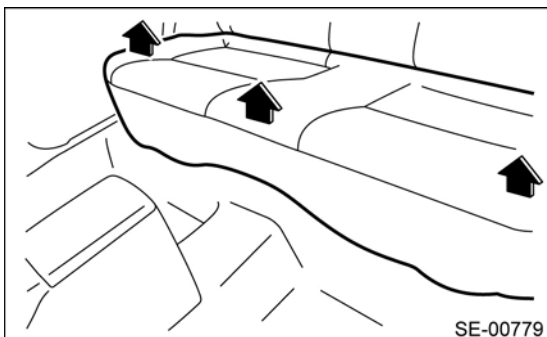

Continued...

Remove the seat cushion

4. Disengage the backrest hook (A) by pushing it back while lifting the front side of the seat cushion. Perform the same procedure on the opposite side. Remove seat cushion from vehicle.

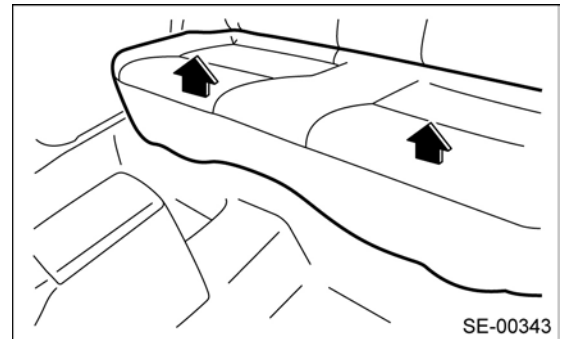
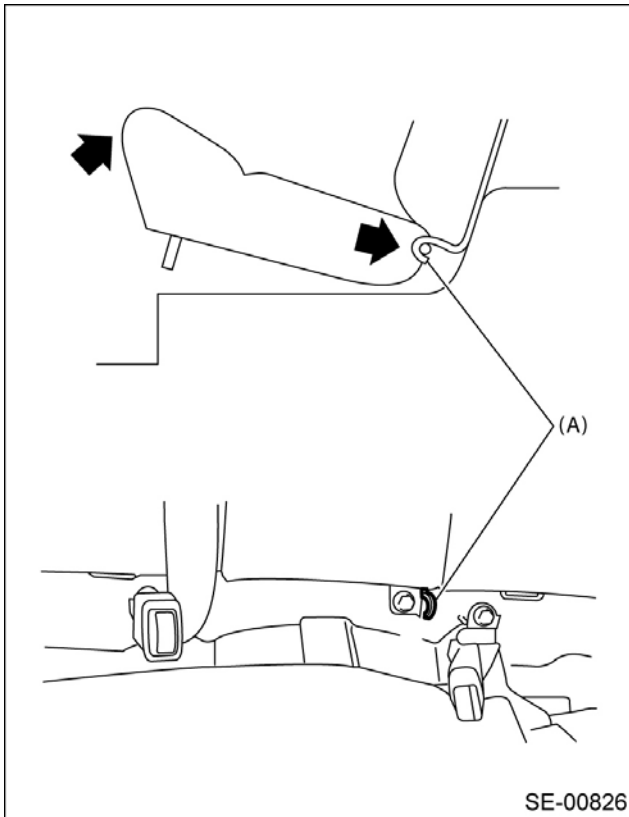

With seat table

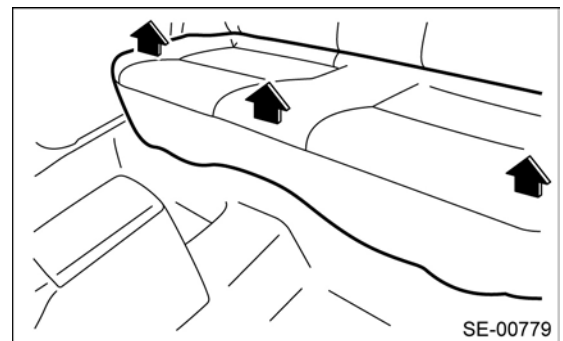

Without seat table

Caution: If the cushion anchor hooks (either two or three, see drawings above) on the vehicle body side are disengaged (remain on the seat cushion) when removing the rear seat cushion, always replace with new cushion anchor hooks to prevent any reduction in the retention force.

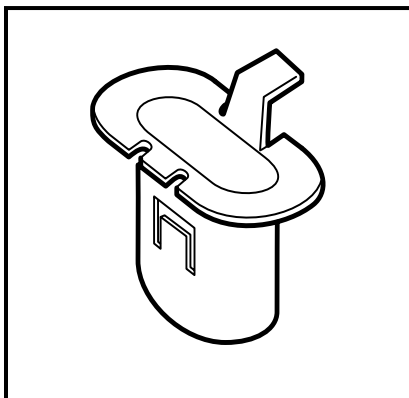

Cushion Anchor Hook

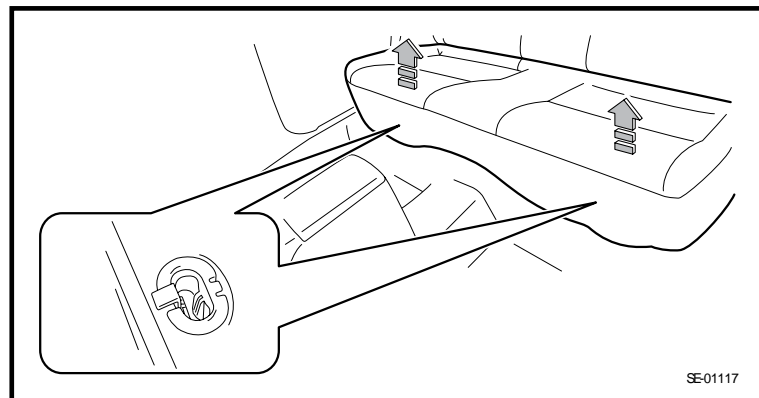

Seat Anchor Locations

Continued...

Note: Make sure to note the orientation of the seatbelts prior to removal.

The center seatbelt with “**Key Slot Release**” requires replacement.
The center seatbelt buckle marked “**Center**” requires replacement.



Note: Make sure to note the location of the seatbelt brackets.



5. Unwrap the Velcro® strap and remove the bolt to remove the seatbelts. Perform the same procedure on the opposite side.

Continued...

6. Separate seatbelt brackets by removing bolt and washer. Discard bolt and washer.



7. Reassemble both belt assemblies using new inner belt and bolt in the same orientation as original. **Note: Washer is not required.**

Caution: Make sure new belt bracket is on the bottom.

8. Reinstall assemblies into vehicle and torque to spec. 30 N-m (3.06 kgf-m, 22.1 ft-lb)

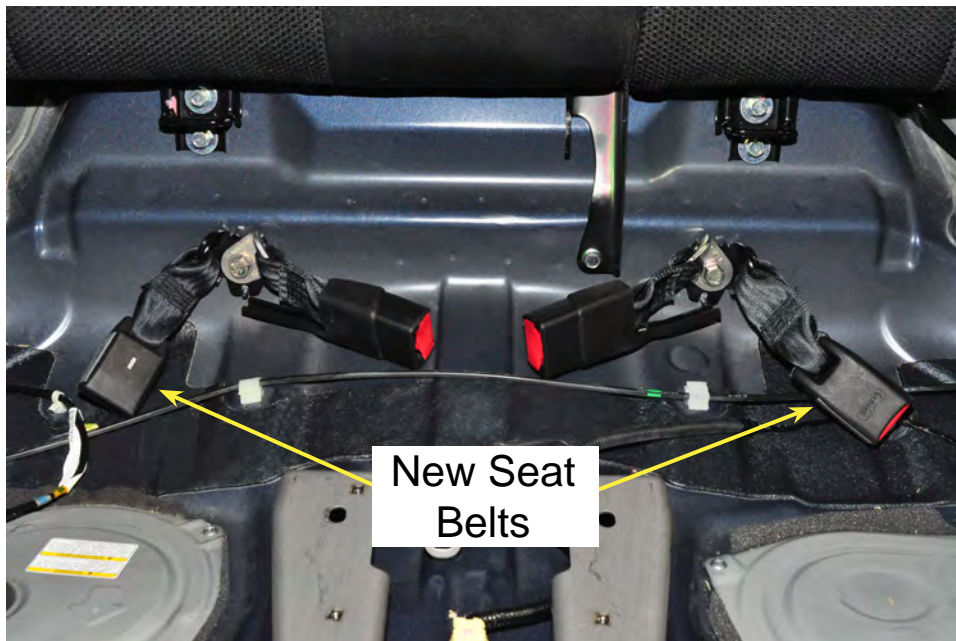

Note: The replacement belts will be shorter than the original belts. This is intentional. Always use matched belt sets. Do not intermix original and campaign belts

Continued...

9. Reinstall the seat cushion. To facilitate positioning of the seatbelts in the cushion, connect all of the seatbelts. The next step will require an assistant. With each person holding the left and right seatbelts respectively, slide the cushion into place while pulling the belt buckles into position in the seat cushion opening.



Continued...

This page should clarify two areas of the Campaign and does not represent any change in procedure. The first clarification is the length of the recall belt. By design, the recall replacement belt is shorter than the original belt.



The second clarification is the final buckle/ latch orientation for the center belt. The red latch release button must face away from the seating position it services. Access to the red latch release button must not be blocked by the belt when it is latched in place for use.



Continued...

10. Disconnect the belts and position the buckles as shown.

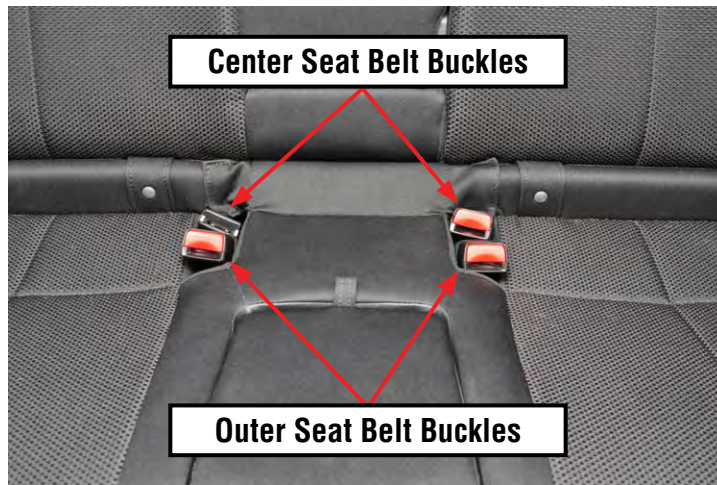

Proper seatbelt buckle(s) positioning

11. (Models with seat table) Connect the table light (white) wiring connector. Install the 4 (10mm) bolts and install trim cover.

Rear center seatbelt

1. Carefully remove the belt trim cover (B). Pull the outer seatbelt center tongue (A) through the headliner opening.

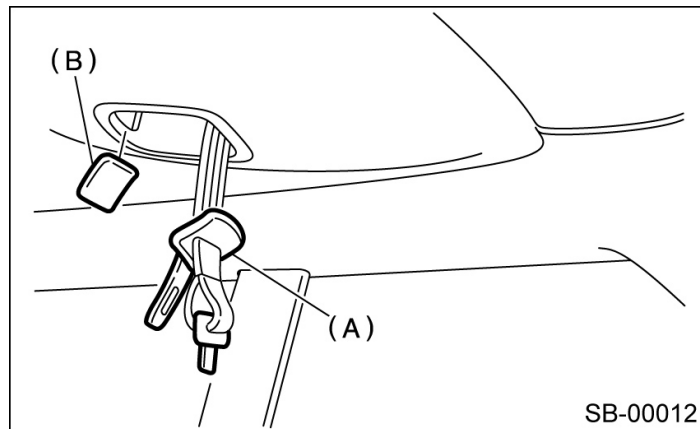

SB-00012

2. Remove the right rear quarter panel trim covers (A) and (B).

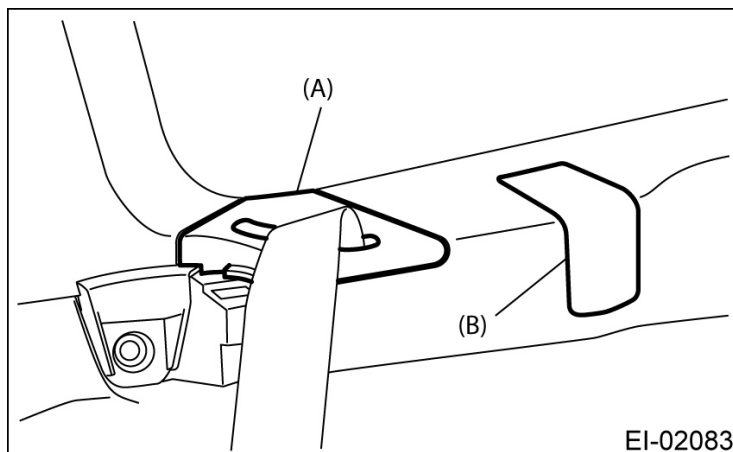

EI-02083

Continued...

3. Remove the front machine screw and 2 rear sheet metal screws from the right rear quarter panel trim.

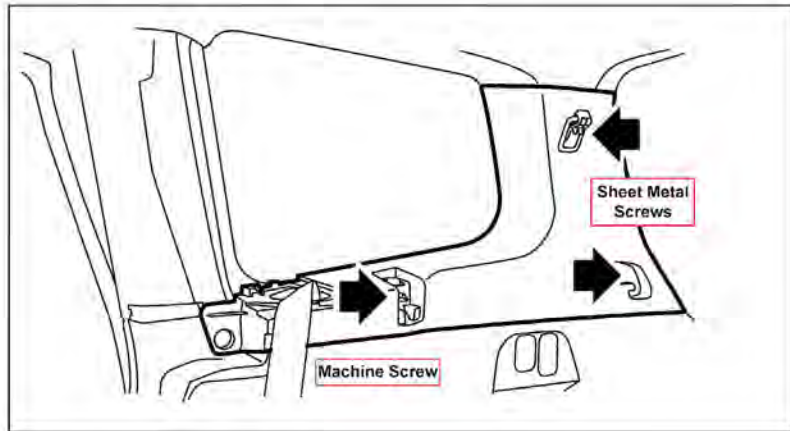

4. Carefully unclip the right rear quarter panel trim from body. It is not necessary to remove the panel. Only move it out slightly to allow the headliner to be lowered. Protect the trim edge from chafing the headliner using a shop rag or other suitable cushion. Unclip the rear upper headliner trim.



Continued...

Caution: Headliner supports will prevent the headliner from creasing or bending, the headliner should not be allowed to drop more than 4 inches on the right side and 1.5 inches on the left side. Headliner supports must be used to prevent damage.

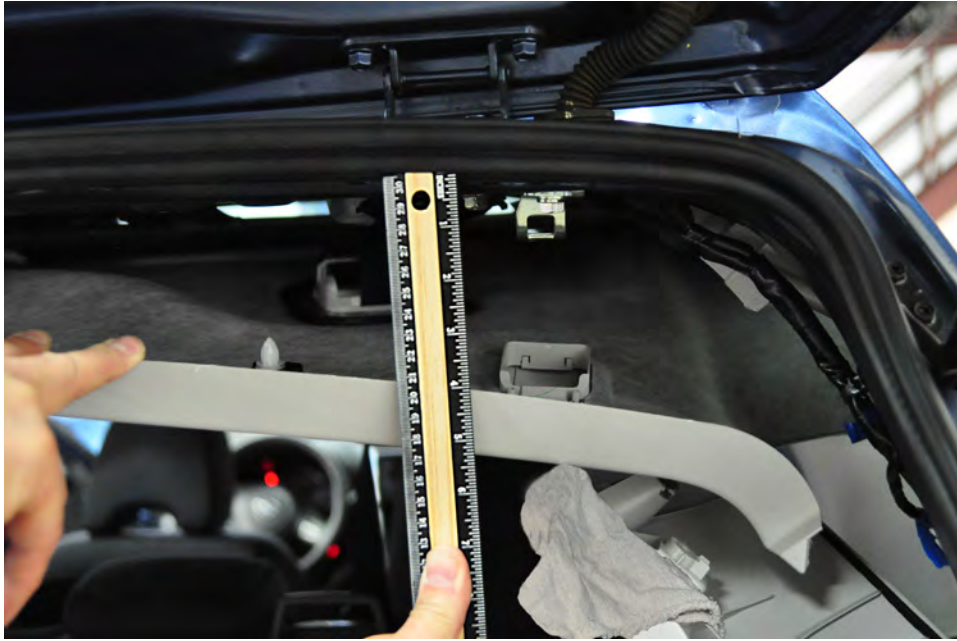

Right side



Left side

Continued...

5. Install headliner supports.



Headliner supports in place



Left side headliner support
Place over the tailgate opening
to bottom edge of headliner



Right side headliner support
Hook to tether anchor, then route
through headliner opening for tether
and attach to rear gate stay.

Note: Use clean shop rags to protect trim and painted surfaces.

6. Remove the bolt and rear center seatbelt.

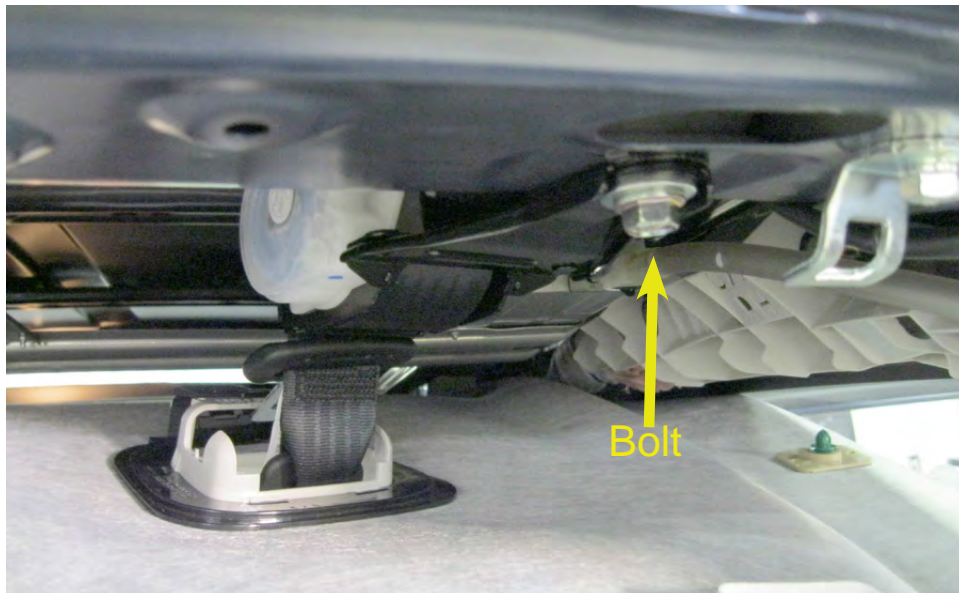

7. Install new rear center seatbelt and bolt.

Caution: Carefully start bolt by hand to prevent cross-threading.

Continued...

8. Torque bolt to *30 N-m (3.06 kgf-m, 22.1 ft-lb)*
9. Remove headliner supports.
10. Install trim in reverse order of removal.
11. Make sure that the seatbelt extends smoothly, retracts properly and the Automatic/Emergency Locking Retractor (ALR/ELR) features function properly.
12. Reconnect ground battery cable.
13. Reset radio stations and set clock.

INSTALLATION INSTRUCTIONS FOR KIT 2

Subaru has prepared a new kit for the WQA-37 recall. Both kits are appropriate, however, Kit 1 will be **reintroduced as soon as inventory of Kit 2 is depleted**. If you have Kit 2 in your inventory, or receive Kit 2 from your PDC, you should continue to install that kit until inventory is depleted. **IMPORTANT:** Never combine parts between kits.

IMPORTANT: PLEASE READ THE COMPLETE PROCEDURE BEFORE ATTEMPTING TO INSTALL KIT 2.

Note: The repair procedure for Kit 2 eliminates the need to replace the rear center seating position retractable shoulder belt assembly located above the head liner.

KIT 2 Components

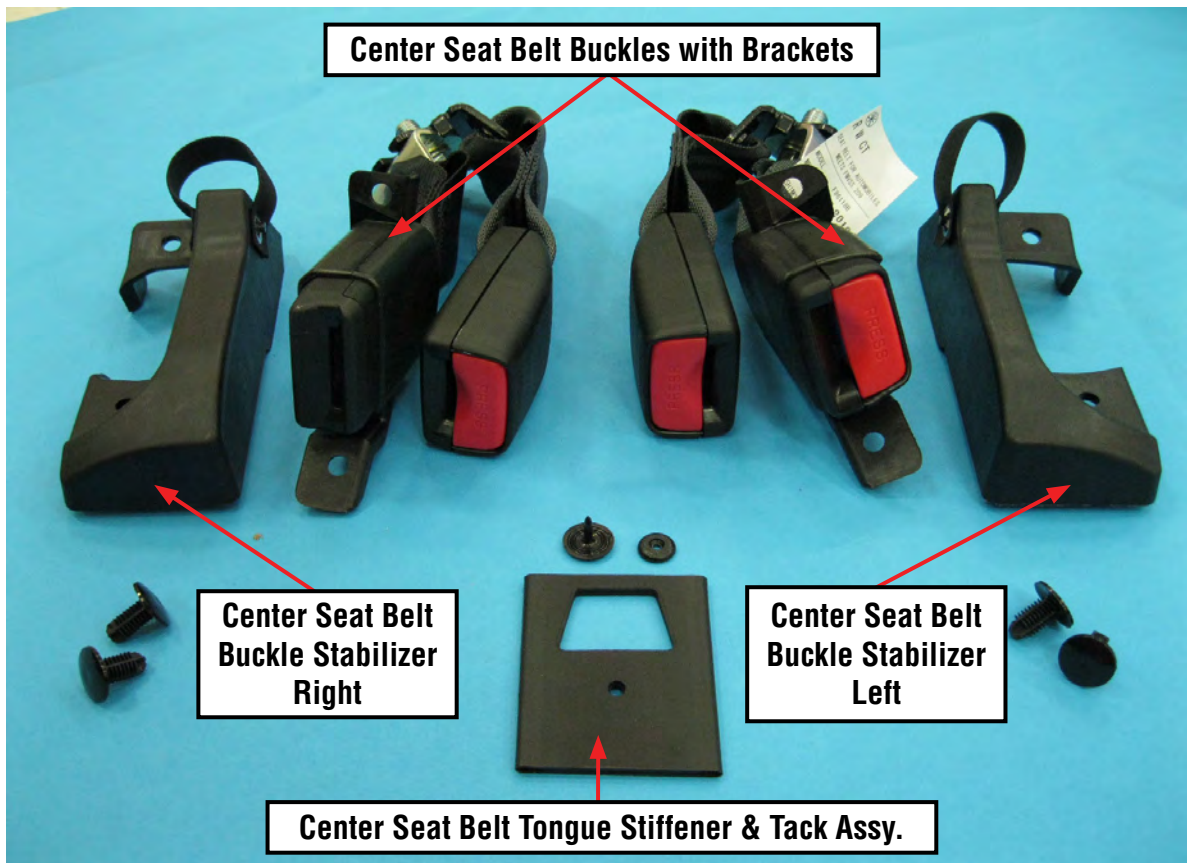

Figure 1: WQA-37 Kit 2

Note: The belts for Kit 2 are shorter than original belts and also shorter than those used for Kit 1. This is intentional.

Continued...

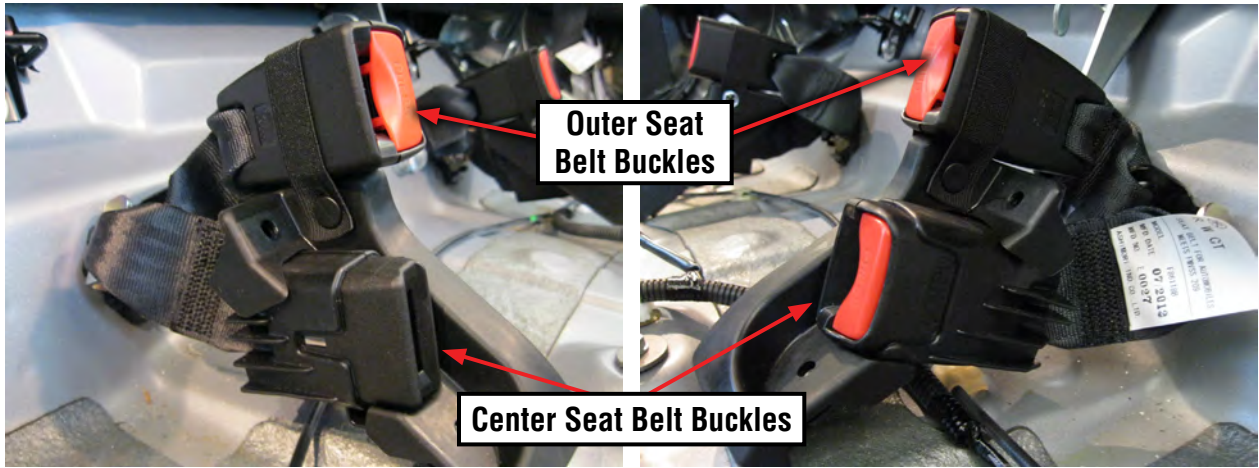

Figure 2: Installed View Passenger side without seat

Figure 3: Installed View Driver side without seat

NOTE: Stabilizers installed in photos below for illustration only. Actual installation occurs later in the procedure.

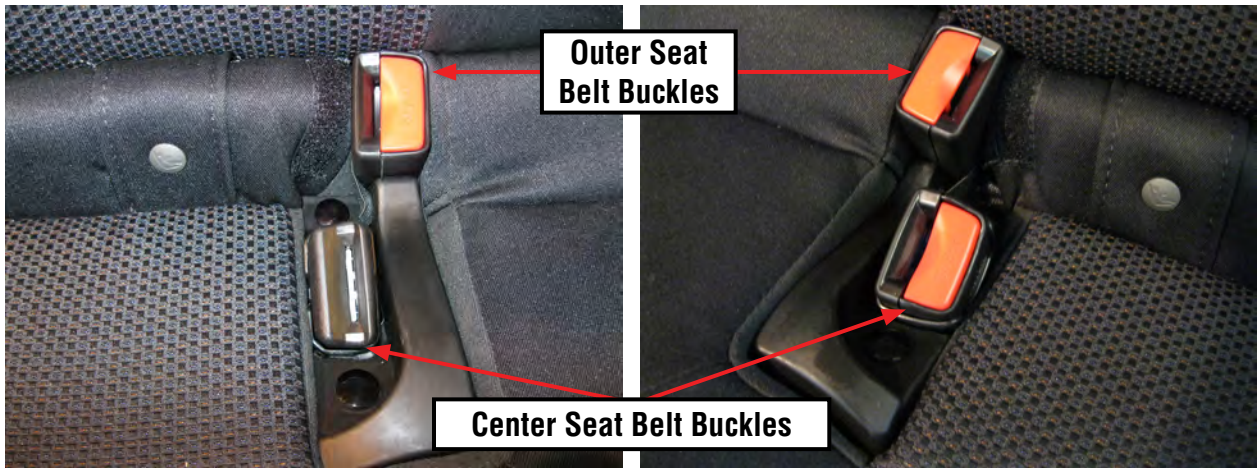
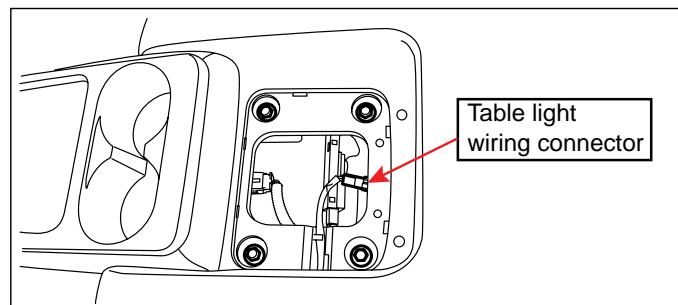

Figure 4: Installed View Passenger side

Figure 5: Installed View Driver side

NOTE: Before beginning, ensure your clothing and hands are free from dirt and grease. Find a clear and clean area to lay the removed rear seat cushion to avoid staining or damaging it.

1. For models with rear seat table, flip open the seat table of the rear seat cushion, **CAREFULLY** remove the storage box floor panel with a plastic trim removal tool then disconnect the white table light wiring harness connector. Remove the 4 (10mm) bolts. **Do not disconnect the airbag satellite safing sensor connector.**



Continued...

- Disengage the backrest hook (A) by pushing it back while lifting the front side of the seat cushion. Perform the same procedure on the opposite side. Remove seat cushion from vehicle.

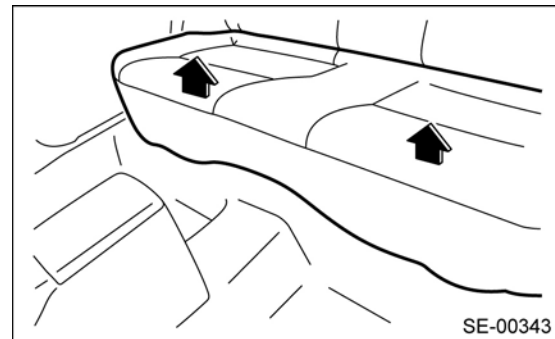
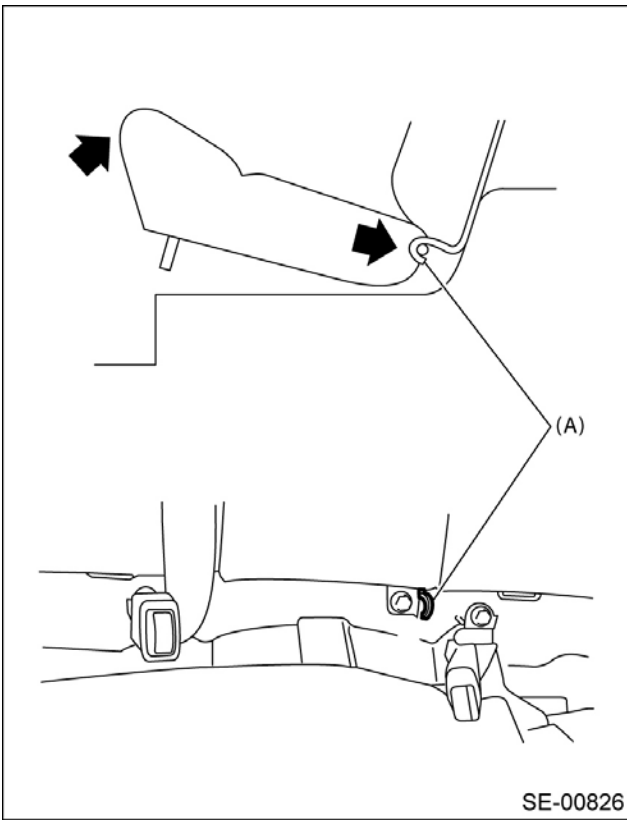

With seat table

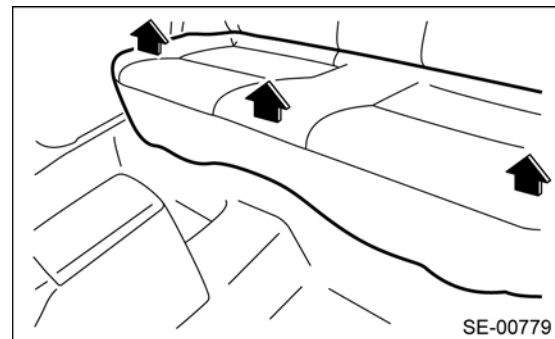

Without seat table

Caution: If the cushion anchor hooks (either two or three, see drawings above) on the vehicle body side are disengaged (remain on the seat cushion) when removing the rear seat cushion, always replace with new cushion anchor hooks to prevent any reduction in the retention force.

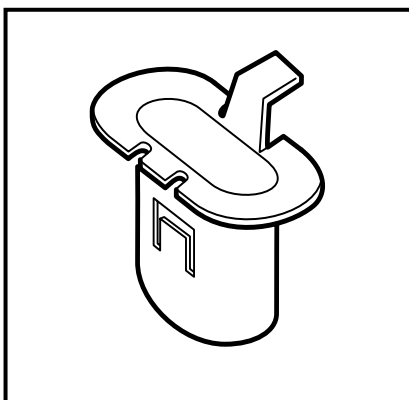

Cushion Anchor Hook

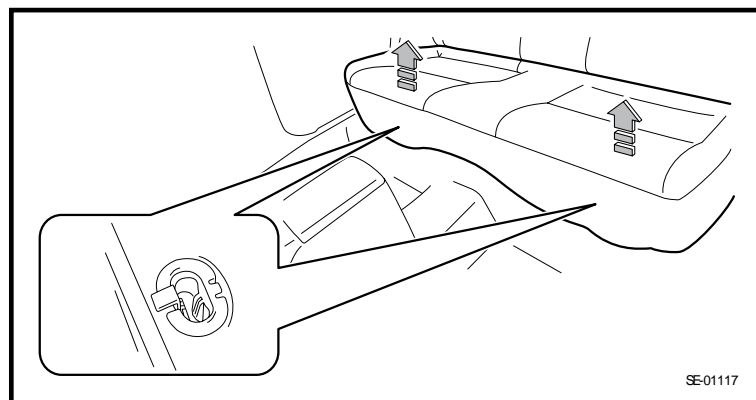

Seat Anchor Locations

Continued...

3. Remove the retaining bolts and remove the center seat belt assemblies.

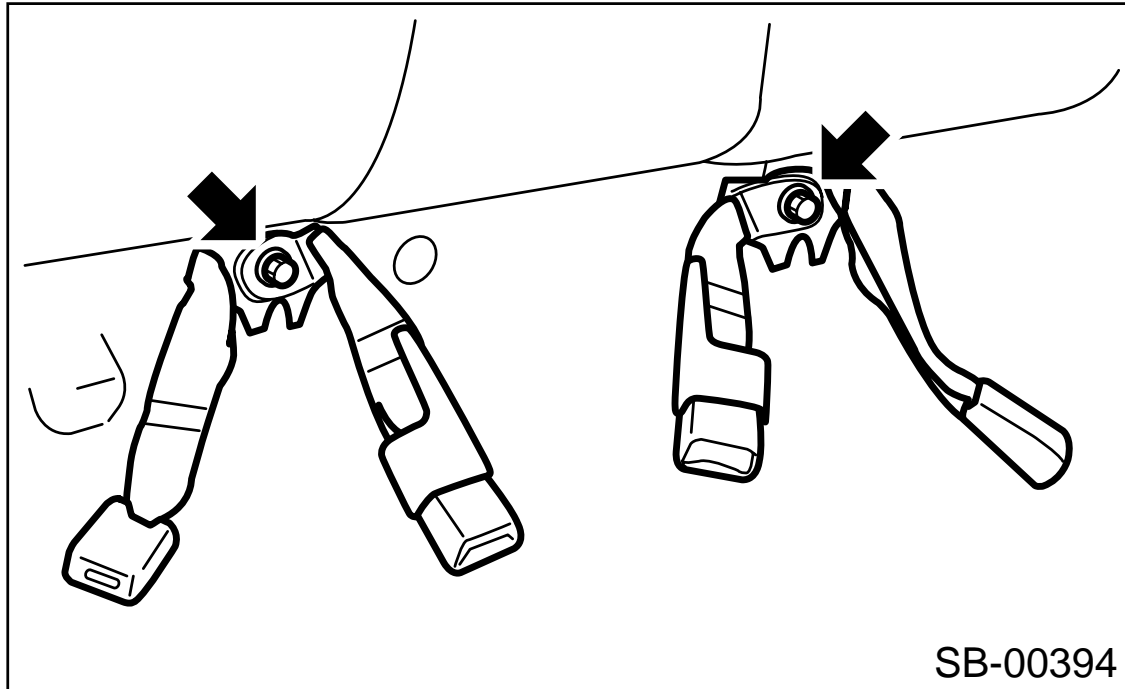

CAUTION:

- During re-installation, make sure that the seat belts are not twisted.
4. Install new seat belts and torque bolts to spec: **30 N-m (3.06 kgf-m, 22.1 ft-lb)**.

Continued...

5. Position the seat belt assemblies as shown in the photo below.



6. Connect the seat belt tongues to all buckles to assist the re-installation of the seat cushion. Extend the outer belt webbing and route them over the headrests as shown below to help hold the buckles and make it easier to re-install the seat cushion.



Continued...

7. Reinstall the seat cushion.

- a. Position the cushion and pull the CENTER buckles into the openings.
- b. Manipulate the brackets on the center belt over the seat openings on both sides.



- c. Disconnect the center seat belt buckles.
- d. Push the seat rearward to almost the fully inserted position.
- e. Push the opening cover flap down into the opening out of view. It will no longer be used after installation of this Kit.



- f. Pull the outer buckles into view and disconnect the belts.
- g. Pull the outer buckles into the opening, above the center buckles on both sides. You can also refer to Figures 2 & 3 for proper positioning.
- h. Leave the outer buckles in the upper part of the opening.



- i. Fully insert the seat cushion and seat the clips.

Continued...

8. Install the Center Buckle Stabilizers.
 - a. Beginning on either side, insert the stabilizer into the opening in the seat, over the CENTER buckle with bracket.
 - b. Make sure the stabilizer is seated properly.
 - c. Push a clip into each hole, connecting the stabilizer to the bracket on the buckle.
 - d. To ensure that the clip is fully seated, hold the assembly up and put fingers under the buckle bracket while inserting the retaining pins as shown in Figure 6 below.



Figure 6

- e. Install the stabilizer on the other side in a similar manner.
- f. Stretch the elastic band over the outer buckles on both sides.



**Figure 7: Completed installation
Passenger side**



**Figure 8: Completed installation
Driver side**

Continued...

9. Center Seat Belt Tongue Stiffener Installation.



- a. Insert the Center Seat Belt Tongue into the stiffener, centering the opening in the stiffener over the bulge of belt material.



- b. Insert the tack through the hole in the stiffener from the smooth side of the belt stitching (opposite of the label).



- c. Place the female collar of the tack onto the pin from the other side.
- d. Using an adjustable wrench as shown, clamp the assembly together and compress the pointed end by first tightening the jaws of the adjustable wrench by hand as far as possible.

Continued...

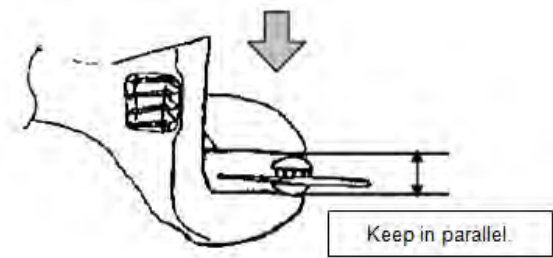

NOTE: Keep male and female portions of the tack assembly parallel while compressing them.

- e. Next, using channel lock pliers, tighten the adjustable wrench gear until the combined height of the tack and belt assembly is ~9.5 to 10.0 mm.



Figure 9: Seating the Tack Collar

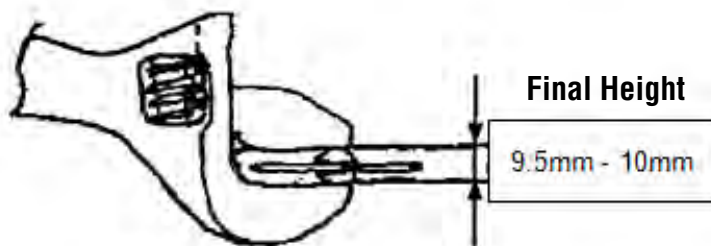

Continued...



NOTE: Confirm that the pin of male tack is compressed as a concentric circle into the hole of collar as shown above.

10. Since the stiffener adds some thickness to the tongue, it may be difficult to insert the tongue into the roof holder. Follow the steps in the photos below.
 - a. Fold the upper tongue over the lower tongue as shown.
 - b. While holding the pieces together, insert both into the opening and push up as shown.



Continued...



SERVICE PROGRAM IDENTIFICATION LABEL

Type or print the necessary information on a Recall Campaign identification label. The completed label should be attached to the vehicle's upper radiator support.

Additional labels are available by calling the Subaru Claims Helpline at: 1-866-782-2782.

SUBARU
Campaign Code
WQA-37
COMPLETED
DIST./DEALER NO.
SERIAL NO.
DO NOT REMOVE

CLAIM REIMBURSEMENT AND ENTRY PROCEDURES

Credit to perform this service program will be based on the submission of properly completed repair order information. Dealers may submit claims through Vehicle Claim Entry on Subarunet.com.

CLAIM TYPE & CAMPAIGN CODE	MODEL	LABOR	PARTS USED	LABOR OPERATION
RC	Forester	191-391 0.5 hrs.	Kit 1	Rear Seat Center Seatbelt Assembly R&R
		191-392 0.4 hrs.	Kit 2	Rear Seat Center Seatbelt Latches R&R

1ST OWNER NOTIFICATION LETTER

Subaru of America, Inc.
Subaru Plaza
P.O. Box 6000
Cherry Hill, NJ 08034-6000
www.subaru.com

Important Safety Recall Notice
Subaru Recall Campaign WQA-37
NHTSA Recall No. 12V-099
March 2012

Dear Subaru Owner:

This notice is sent to you in accordance with the requirements of the National Traffic and Motor Vehicle Safety Act.

SUBARU OF AMERICA, INC. has decided that the rear seat center seatbelt on certain 2009 through 2012 model year Forester vehicles fails to conform to one of the requirements of Federal Motor Vehicle Safety Standard No. 208, "Occupant Crash Protection".

DESCRIPTION OF THE NONCOMPLIANCE

Subaru has determined that your vehicle has been manufactured with a rear seat center seatbelt that does not comply with the Federal Motor Vehicle Safety Standard requirement for securing a child restraint system (CRS) also known as a "child safety seat".

DESCRIPTION OF THE SAFETY HAZARD

The rear center seatbelt may not adequately secure certain CRSs that require a short belt routing configuration for attachment. This seatbelt contains an Automatic Locking Retractor that may not lock as intended when such a configuration is used, preventing a tight and secure installation of the CRS. If the CRS is not properly secured, the CRS may not provide the protection it was designed to provide, and the child occupying the CRS may be at an increased risk of injury in the event of a crash.

REPAIRS

In the interest of safety, Subaru is sending this notice to you before repair parts are available. A second notification letter will be sent to you when repair parts become available. At that time, Subaru will repair the rear seat center seatbelt assembly at no cost to you.

Continued...

PRECAUTIONS YOU SHOULD TAKE

A CRS should NOT be used in the rear seat center position until the seatbelt assembly has been repaired. As recommended in your vehicle's Owner's Manual, the left or right rear seating positions should be used for installation of a CRS. Please refer to your vehicle's Owner's Manual for proper seatbelt usage instructions.

ADDITIONAL INFORMATION

The condition described only poses a safety risk when a CRS is installed in the rear seat center position. Otherwise, this seatbelt will operate normally and provide the intended occupant protection. Other seatbelts in the vehicle are not affected by this condition.

In the event your needs are such that a CRS must be installed in the rear seat center position, please contact Subaru immediately for assistance. We can be contacted in the following ways:

- Telephone: 1-800-SUBARU3 (1-800-782-2783) Monday through Thursday between 8:30 a.m. and 7:00 p.m. ET and Friday between 10:30 a.m. and 5:00 p.m. ET.
- E-mail: Go to www.subaru.com and select "Contact Us".
- U.S. Postal mail: Write us at Subaru of America, Inc., Attn: CDS Department, P.O. Box 6000, Cherry Hill, NJ 08034-6000.

For additional information and the most Frequently Asked Questions, please go to:

- <http://www.wqa37.service-campaign.com>

CHANGED YOUR ADDRESS OR SOLD YOUR SUBARU?

If you have moved or sold your vehicle, please complete the enclosed prepaid postcard and mail it to us.

Your continued satisfaction with your Subaru is important to us. Please understand that we have taken this action in the interest of your safety and your vehicle's proper operation. We sincerely apologize for any inconvenience this matter may cause. As we mentioned, a second notification letter will be sent to you when the repair parts become available.

Sincerely,
Subaru of America, Inc.

Notice to Lessors

Under Federal law the lessor of a vehicle who receives this letter must provide a copy of it to the vehicle lessee(s) within 10 business days from receipt. The lessor must also keep a record of the lessee(s) to whom this letter is sent, the date sent, and the applicable vehicle identification number (VIN). (For the purposes of this section, a lessor means a person or entity that in the last twelve months prior to the date of this notification has been the owner, as referenced on the vehicle's title, of any five or more leased vehicles. A leased vehicle is a vehicle leased to another person for a term of at least four months.)

A subsidiary of Fuji Heavy Industries Ltd.

2ND OWNER NOTIFICATION LETTER

Subaru of America, Inc.
Subaru Plaza
P.O. Box 6000
Cherry Hill, NJ 08034-6000
www.subaru.com

Important Safety Recall Notice
Subaru Recall Campaign WQA-37
NHTSA Recall No. 12V-099
June 2012

Dear Subaru Owner:

This notice is sent to you in accordance with the requirements of the National Traffic and Motor Vehicle Safety Act.

In March 2012, we notified you that Subaru of America, Inc. decided that the rear seat center seatbelt on certain 2009 through 2012 model year Forester vehicles fails to conform to one of the requirements of Federal Motor Vehicle Safety Standard No. 208, "Occupant Crash Protection". We informed you that we would send you a second letter when repair parts became available. Those parts are now available.

DESCRIPTION OF THE NONCOMPLIANCE

Subaru has determined that your vehicle has been manufactured with a rear seat center seatbelt that does not comply with the Federal Motor Vehicle Safety Standard requirement for securing a child restraint system (CRS) also known as a "child safety seat".

DESCRIPTION OF THE SAFETY HAZARD

The rear center seatbelt may not adequately secure certain CRSs that require a short belt routing configuration for attachment. This seatbelt contains an Automatic Locking Retractor that may not lock as intended when such a configuration is used, preventing a tight and secure installation of the CRS. If the CRS is not properly secured, the CRS may not provide the protection it was designed to provide, and the child occupying the CRS may be at an increased risk of injury in the event of a crash.

REPAIRS

To correct this condition, Subaru will repair the rear seat center seatbelt assembly at no cost to you.

WHAT YOU SHOULD DO

You should immediately contact your Subaru dealer and schedule an appointment to have the rear seat center seatbelt assembly repaired.

PRECAUTIONS YOU SHOULD TAKE

A CRS should NOT be used in the rear seat center position until the seatbelt assembly

Continued...

has been repaired. As recommended in your vehicle's Owner's Manual, the left or right rear seating positions should be used for installation of a CRS. Please refer to your vehicle's Owner's Manual for proper seatbelt usage instructions.

HOW LONG WILL THE REPAIR TAKE?

The actual time to repair the rear seat center seatbelt is approximately 30 minutes. However, it may be necessary to leave your vehicle for a longer period of time on the day of your scheduled appointment to allow your dealer flexibility in scheduling. Please present this letter to your Subaru Dealer at the time this repair procedure is performed.

ADDITIONAL INFORMATION

The condition described only poses a safety risk when a CRS is installed in the rear seat center position. Otherwise, this seatbelt will operate normally and provide the intended occupant protection. Other seatbelts in the vehicle are not affected by this condition.

IF YOU HAVE PREVIOUSLY PAID FOR THIS REPAIR

If you have already paid for repairs associated with this condition prior to receiving this notice, you may be eligible for reimbursement. For more information contact Subaru at 1-800-782-2783.

CHANGED YOUR ADDRESS OR SOLD YOUR SUBARU?

If you have moved or sold your vehicle, please complete the enclosed prepaid postcard and mail it to us.

IF YOU NEED FURTHER ASSISTANCE

To locate the nearest Subaru Dealer you can access our website at www.subaru.com and select "Find a Dealer".

For additional information and the most Frequently Asked Questions, please go to:

- <http://www.wqa37.service-campaign.com>

If you need additional assistance, please contact us directly:

- Telephone: 1-800-SUBARU3 (1-800-782-2783)
Monday through Thursday between 7:30 a.m. and 8:00 p.m. ET
Friday between 10:30 a.m. and 5:00 p.m. ET
Saturday between 9:00 a.m. and 3:30 p.m. ET
- E-mail: Go to www.subaru.com and select "Contact Us".
- U.S. Postal mail: Write us at Subaru of America, Inc., Attn: CDS Department, P.O. Box 6000, Cherry Hill, NJ 08034-6000.

Please contact us immediately if the dealer fails or is unable to make the necessary repairs free of charge.

Continued...

You may also contact the Administrator, National Highway Traffic Safety Administration, 1200 New Jersey Ave. SE, Washington, DC 20590 or call the toll free Auto Safety Hotline at 1-888-327-4236 (TTY: 1-800-424-9153) or go to <http://www.safercar.gov> if you believe the dealer has failed or is unable to remedy your vehicle without charge within a reasonable amount of time.

Your continued satisfaction with your Subaru is important to us. Please understand that we have taken this action in the interest of your safety and your vehicle's proper operation. We sincerely apologize for any inconvenience this matter may cause and urge you to schedule an appointment as soon as possible to have this repair performed.

Sincerely,
Subaru of America, Inc.

Notice to Lessors

Under Federal law the lessor of a vehicle who receives this letter must provide a copy of it to the vehicle lessee(s) within 10 business days from receipt. The lessor must also keep a record of the lessee(s) to whom this letter is sent, the date sent, and the applicable vehicle identification number (VIN). (For the purposes of this section, a lessor means a person or entity that in the last twelve months prior to the date of this notification has been the owner, as referenced on the vehicle's title, of any five or more leased vehicles. A leased vehicle is a vehicle leased to another person for a term of at least four months.)

A subsidiary of Fuji Heavy Industries Ltd.

Left Side

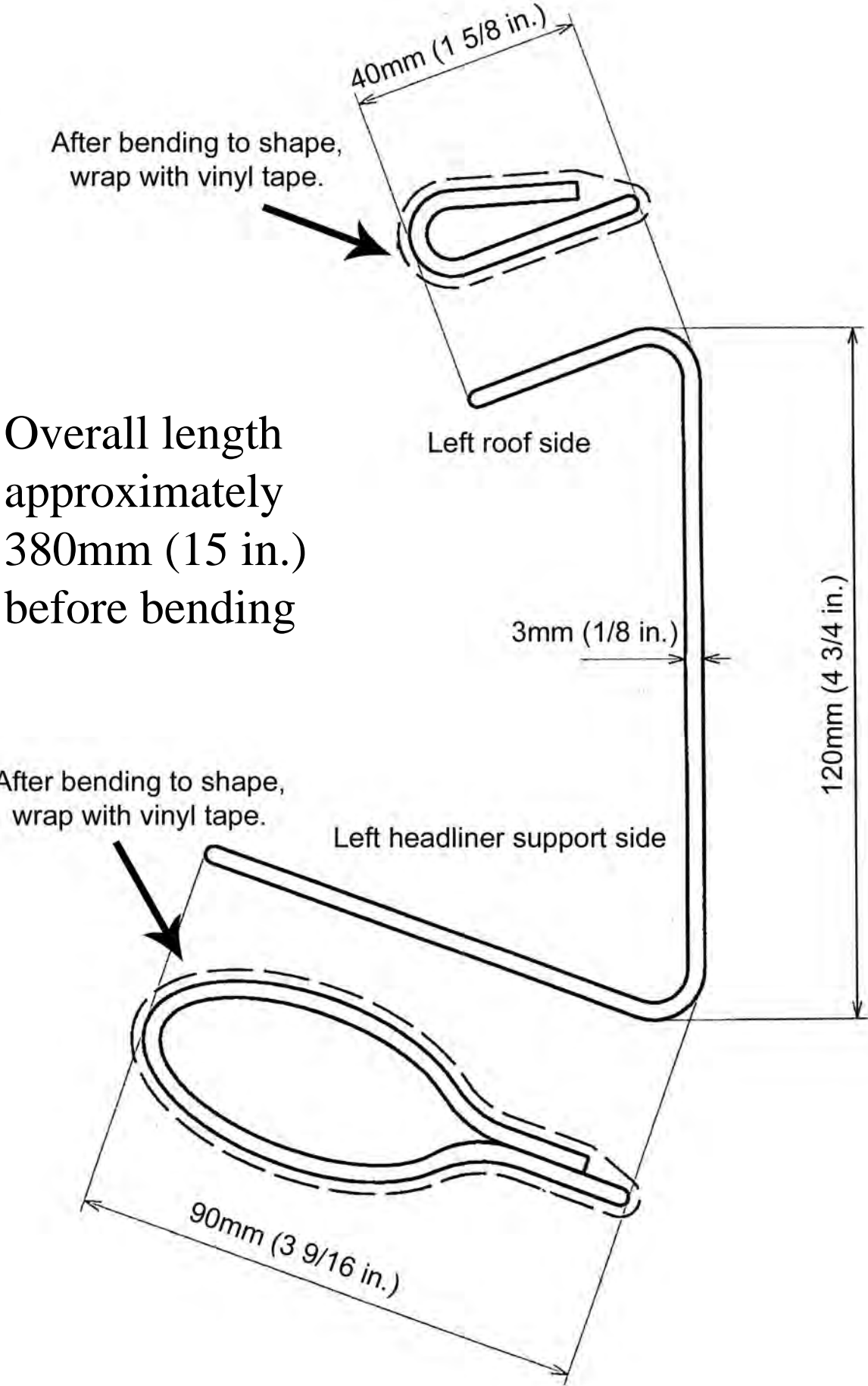

Right Side

