



Stacy L. Balzer  
 Operating Director  
 Service Engineering Operations  
 Ford Customer Service Division

Ford Motor Company  
 P. O. Box 1904  
 Dearborn, Michigan 48121

November 17, 2022

**TO:** All U.S. Ford and Lincoln Dealers

**SUBJECT:** **Customer Satisfaction Program 21M06 - Supplement #1**  
 Certain 2015-2020 Model Year F-150 Vehicles Equipped with a Power Release Tailgate - Unintended Tailgate Opening

**REF:** **Customer Satisfaction Program 21M06**  
 Dated May 20, 2022

**New! REASON FOR THIS SUPPLEMENT**

*Parts ordering information and full repair instructions are now available to support completion of this customer satisfaction program.*

**PROGRAM TERMS**

This program provides a no-cost repair (if needed) to the power release tailgate feature for 10 years of service or 150,000 miles from the warranty start date of the vehicle, whichever occurs first.

This program may be used multiple times as long as the vehicle is within time and mileage limits of the program. Once the program has expired, Service Part Warranty (SPW) and Extended Service Plan (ESP) may be eligible.

If a vehicle has already exceeded either the time or mileage limits, this no-cost repair will last through May 31, 2023.

Coverage is automatically transferred to subsequent owners.

**VEHICLES COVERED BY THIS PROGRAM**

Vehicle	Model Year	Assembly Plant	Build Dates
F-150	2015-2020	Dearborn	March 18, 2014 through September 5, 2020
		Kansas City	August 11, 2014 through October 22, 2020

Affected vehicles are identified in OASIS.

**REASON FOR PROVIDING A NO-COST REPAIR**

In the affected vehicles, some customers report experiencing an unintended tailgate opening and may have previously serviced their vehicle for this concern. Ford has developed an enhanced remedy for customers who may want this enhanced repair performed on their vehicle.

**New! SERVICE ACTION**

Some vehicles covered by Field Service Action (FSA) 21M06 may have FSA 20S01 or 20N03 currently open. Please check OASIS to verify coverage and perform FSA 20S01 or 20N03 ONLY if coverage applies. DO NOT perform FSA 20S01 or 20N03 on vehicles that are not included in those programs.

If a vehicle included in FSA 21M06 has sustained damage to the tailgate due to an unintended tailgate opening, please refer to the claiming instructions for related damage.

***Service Action Continued On The Next Page***

**New! SERVICE ACTION (continued)**

**NOTE:** For model years 2015-2018, Safety Recall 20S01 (Canada) or Customer Satisfaction Program 20N03 (United States) must be completed prior to performing the 21M06 service procedure.

If an affected vehicle owner has reported an unintended tailgate opening, dealers are to modify the power release tailgate system wiring, install a new tailgate handle release switch and reprogram the BCM software using Integrated Diagnostic Software (IDS) release 128.01 or higher.

**Customer Information Sheet and Owner's Manual Addendum:** At the completion of this repair, dealership service management is to provide a copy of the "Customer Information Sheet" and "Owner's Manual Addendum" that is posted with this bulletin to the vehicle owner.

This service must be performed on all affected vehicles at no charge to the vehicle owner.

**NOTE:** Ford Diagnosis and Repair System (FDRS) cannot be used for programming on the 2015-2020 F-150 vehicles.

**NOTE:** The tailgate is required to perform the repair but does not need to be installed on the vehicle.

**New! OWNER NOTIFICATION MAILING SCHEDULE**

Owners of affected vehicles have been notified. Parts available owner letters are expected to start mailing the week of November 28, 2022. Dealers should repair any affected vehicles that experience unintended tailgate opening, whether or not the customer has received a letter.

**New! ATTACHMENTS**

Attachment I: Administrative Information  
Attachment II: Labor Allowances and Parts Ordering Information  
Attachment III: Technical Information  
Customer Information Sheet  
Owner's Manual Addendum  
Owner Notification Letter

**QUESTIONS & ASSISTANCE**

For questions and assistance, contact the Special Service Support Center (SSSC) via the SSSC Web Contact Site. The SSSC Web Contact Site can be accessed through the Professional Technician System (PTS) website using the SSSC link listed at the bottom of the OASIS VIN report screen or listed under the SSSC tab.

Sincerely,



Stacy L. Balzer

**Customer Satisfaction Program 21M06 - *Supplement #1***  
Certain 2015-2020 Model Year F-150 Vehicles Equipped with a Power Release Tailgate  
Unintended Tailgate Opening

**OASIS ACTIVATION**

OASIS was activated on May 20, 2022.

**FSA VIN LISTS ACTIVATION**

FSA VIN Lists will not be activated for this service action.

**SOLD VEHICLES**

- Only owners with affected vehicles that exhibit the covered condition will be directed to dealers for repairs.
- Dealers are to prioritize repairs of customer vehicles over repairs of new and used vehicle inventory.

**STOCK VEHICLES**

Do not perform this program unless the affected vehicle exhibits the covered condition.

**TITLE BRANDED / SALVAGED VEHICLES**

Vehicles with cancelled warranties are not eligible for this service action.

**New! OWNER REFUNDS**

- *Ford Motor Company is offering a refund for owner-paid repairs covered by this program if the repair was performed before December 16, 2022. This refund offer expires **May 31, 2023**.*
- Dealers are also pre-approved to refund owner-paid emergency repairs that were performed away from an authorized servicing dealer after the date of the Owner Notification Letter. Non-covered repairs, or those judged by Ford to be excessive, will not be reimbursed.
- Refunds will only be provided for the cost associated with repairs associated with unintended tailgate opening.

**RENTAL VEHICLES**

The use of rental vehicles is not approved for this program.

**RELATED DAMAGE PHOTO SUBMISSION**

Ford requires photos for any related damage claims associated with this program.

Please submit an Approval Request to the SSSC Web Contact Site containing clear photos of the VIN and all related damage, including the component(s) that contacted the vehicle (if possible), for approval consideration.

**ADDITIONAL REPAIR (LABOR TIME AND/OR PARTS)**

Additional repairs identified as necessary to complete the FSA should be managed as follows:

- For related damage and access time requirements, refer to the Warranty and Policy Manual – Section 6 – Ford & Lincoln Program Policies / General Information & Special Circumstances for FSA's / Related Damage.
- For vehicles within new vehicle bumper-to-bumper warranty coverage, SSSC approval is still required.
- For vehicles outside new vehicle bumper-to-bumper warranty coverage, submit an Approval Request to the SSSC Web Contact Site prior to completing the repair.

**Customer Satisfaction Program 21M06 - Supplement #1**  
 Certain 2015-2020 Model Year F-150 Vehicles Equipped with a Power Release Tailgate  
 Unintended Tailgate Opening

**New! CLAIMS PREPARATION AND SUBMISSION**

- **Note:** All repairs for this program should be claimed using the claim entry direction below regardless if the vehicle is still under the New Vehicle Limited Warranty.
  - Service Part Warranty (SPW) and/or Ford/Lincoln Loyalty Plans (ESP) eligible vehicles – Claim repairs to FSA 21M06 if vehicle is still within time and mileage limits.
- **Claim Entry:** Enter claims using Dealer Management System (DMS) or One Warranty Solution (OWS) online.
  - When entering claims:
    - Claim type 31: Field Service Action. The FSA number (21M06) is the sub code.
    - Customer Concern Code (CCC): L07 – Ext. Door Lock Controls-Power
    - Condition Code (CC): 42 – Does Not Operate Properly
    - Causal Part Number: 9C888 – Tailgate Switch
    - Part Quantity: 0
  - For additional claims preparation and submission information, refer to the Recall and Customer Satisfaction Program (CSP) Repairs in the OWS User Guide.
- **Related Damage/Additional labor and/or parts:** Must be claimed as Related Damage on a separate repair line from the FSA with same claim type and sub code as described in Claim Entry above.
 

**IMPORTANT:** Click the Related Damage Indicator radio button.
- **Refunds:** Submit refunds on a separate repair line.
  - Program Code: 21M06                      - Misc. Expense: ADMIN
  - Misc. Expense: REFUND                      - Misc. Expense: 0.2 Hrs.
  - Multiple refunds should be submitted on one repair line and the invoice details for each repair should be detailed in the comments section of the claim.
- **Provision for Locally Obtained Tool and Supplies:** *Includes Coroplast® 837 engineered electrical wire harness tape or equivalent, black electrical tape, TA-32 (as needed), XG-12 (as needed), rosin core solder and one 1-1/2 inch (38 mm) Bi-Metal Hole Saw with arbor and pilot bit (as needed). This provision is for the amount of supplies used for one vehicle repair and the tool which can be used for multiple repairs. Submit on the same repair line on which the FSA is claimed.*

**NOTE:** *The locally obtained supplies and the 1-1/2 inch (38 mm) Bi-Metal Hole Saw tool can be used on multiple vehicles.*

**NOTE:** *The \$20.00 provision for the 1-1/2 inch (38 mm) Bi-Metal Hole Saw is a one-time charge per dealer. Do not charge this amount more than once.*

  - Program Code: 21M06
  - Misc. Expense: OTHER
  - Misc. Expense: Claim up to \$24.00 (includes up to \$4.00 for locally obtained supplies and up to \$20.00 for the locally obtained 1-1/2 inch (38 mm) Bi-Metal Hole Saw tool)
- **Provision for Sublet Windshield Removal/Installation:** *This expense cannot be claimed if the dealership removes and installs the windshield. Sublet documentation must be retained. Submit on the same line as the repair.*
  - Program Code: 21M06 - Misc. Expense: FSAOSL - Misc. Expense: Claim up to \$250.00



**Customer Satisfaction Program 21M06 - Supplement #1**  
 Certain 2015-2020 Model Year F-150 Vehicles Equipped with a Power Release Tailgate  
 Unintended Tailgate Opening

**New! LABOR ALLOWANCES**

Description	Labor Operation	Labor Time
<p><b>NOTE: For model years 2015-2018, Safety Recall 20S01 (Canada) or Customer Satisfaction Program 20N03 (United States) must be completed prior to performing the 21M06 service procedure.</b></p> <p><i>Inspect BCM, Install Tailgate Actuator Ground Wiring Kit, Replace Tailgate Handle Release Switch, Update BCM Software Using IDS Release 128.01 or Higher, Enable the Tailgate Switches Double Press, Select Brake Transmission Shift Interlock (BTSI) Relay Installed and Disable Tailgate Ajar Message (if equipped) Via the IDS Programable Parameters and Print <u>Both</u> the Customer Information Sheet and the Owner's Manual Addendum.*</i></p> <p><b>NOTE: The tailgate is required to perform the repair but does not need to be installed on the vehicle</b></p> <p><b>NOTE: Camera alignment is not required</b></p> <p><b>NOTE: FDRS cannot be used on the affected vehicles</b></p> <p>- Can be claimed in combination with 21M06C and/or 21M06D</p>	21M06B	3.2 Hours
<p><i>Additional Time to Install the Tailgate Jumper Pigtail on the 2019 and 2020 Model Year Vehicles only.</i></p> <p>- Can be claimed in combination with 21M06B and/or 21M06D</p>	21M06C	0.9 Hours
<p><b>NOTE: This labor operation is to be claimed ONLY if the BCM connector(s) or fuse(s) exhibit signs of moisture and/or corrosion contamination. Photo(s) of BCM contamination MUST be submitted to the SSSC <u>prior to</u> diagnostics in order to use this labor operation.</b></p> <p><i>Diagnose and Repair the Source(s) of the BCM Moisture and/or Corrosion Contamination.**</i></p> <p>- Can be claimed in combination with 21M06B and/or 21M06C</p>	MT21M06D	Actual time up to 10.0 Hours***
Time Allowed to Submit Photos for Related Damage Claims (As Needed)	21M06ZZ	0.2 Hours

\* **Customer Information Sheet and Owner's Manual Addendum:** At the completion of this repair, dealership service management is to provide a copy of both the "Customer Information Sheet" and the "Owner's Manual Addendum" that are posted with this bulletin to the vehicle owner.

\*\* Less than 3% of the affected vehicle population is expected to require water leak diagnostics.

\*\*\* Dealers are authorized to claim up to 10.0 hours actual time after contacting the SSSC Web Contact Site and submitting photo(s) for approval. Follow the Actual Time Usage Guidelines and Service Management Responsibilities as identified in the Warranty and Policy Manual. Claims for additional parts and/or labor over 10.0 hours should be submitted to the SSSC as a Related Damage contact. If contacting SSSC, please provide the complete tech details and time stamps to support the request for the additional time.

**Customer Satisfaction Program 21M06 - Supplement #1**  
 Certain 2015-2020 Model Year F-150 Vehicles Equipped with a Power Release Tailgate  
 Unintended Tailgate Opening

**New! PARTS REQUIREMENTS / ORDERING INFORMATION**

<b>Part Number</b>	<b>Description</b>	<b>Order Quantity</b>	<b>Claim Quantity</b>
LL3Z-14A411-P	Tailgate Actuator Ground Wiring Kit	1	1
LL3Z-14A411-D	Tailgate Jumper Pigtail Kit	As Needed	
GB5Z-9C888-B	Tailgate Handle Release Switch	1	1
PM-13-B or Equivalent	Motorcraft® Anti-Corrosion Coating* (Only F-150 Super Cab vehicles, As Needed) - Check dealer inventory before ordering additional quantities. - 16 fl. Oz per container, sell pack of 1, 1/2 Oz per repair, repair 32 vehicles per can.	As Needed	.03
TA-32	Motorcraft® TA-32 Clear Silicone Rubber* (As Needed)	Claim as Misc. OTHER	
XG-12	Motorcraft® Electrical Grease* (As Needed) - One 3 oz. tube will service approximately 15 vehicles		
Obtain Locally	Engineered Electrical Wire Harness Tape* Coroplast® 837 or Equivalent. - Can be obtained from Rotunda or Nairn (NAI837X). - Package of 3 or 6 rolls.		
	Rosin Core Solder*		
	Black Electrical Tape* (As Needed)		

\* The listed tapes and chemicals can be used on multiple vehicles.

Order your parts requirements through normal order processing channels. To guarantee the shortest delivery time, an emergency order for parts must be placed.

**DEALER PRICE**

For latest prices, refer to DOES II.

**PARTS RETENTION, RETURN, & SCRAPPING**

Follow the provisions of the Warranty and Policy Manual, Section 1 - WARRANTY PARTS RETENTION AND RETURN POLICIES. If a replaced part receives a scrap disposition, the part must be scrapped in accordance with all applicable local, state and federal environmental protection and hazardous material regulations.

**EXCESS STOCK RETURN**

Excess stock returned for credit must have been purchased from Ford Customer Service Division in accordance with Policy Procedure Bulletin 4000.

**Customer Satisfaction Program 21M06 - Supplement #1**

Certain 2015-2020 Model Year F-150 Vehicles Equipped with a Power Release Tailgate  
Unintended Tailgate Opening

**REPLACED FSA PARTS INSPECTION AND SIGN OFF**

Effective March 1<sup>st</sup> 2021 all parts replaced as part of an FSA repair with a repair order open date of March 1<sup>st</sup> 2021 or later must be inspected and signed off on the repair order by a member of your dealers fixed operations management team or an employee the task has been delegated to. If the task is to be delegated to a non-management employee, the employee needs to be someone other than the technician who completed the repair and needs to understand the importance of completing this task consistently and accurately.

- All parts replaced as part of an FSA repair should be returned to the parts department following the Warranty Parts Retention and Return Policies.
- Inspect the replaced parts to verify the FSA repair was completed.
- If the FSA repair is found to be complete, the designated employee signs the repair order line or parts return stamp area (electronic or hand signed) for the FSA repair indicating the parts were inspected and validated to have been replaced.
- After the parts have been inspected, they should be handled based on the guidance in the parts status report in the Online Warranty System (Hold, Return, CORE, Scrap, etc.).
- This process is subject to review during warranty audits for FSA repairs with a repair order open date of March 1<sup>st</sup> 2021 or later. Any eligible FSA claims requiring parts replacement, found not to have been inspected and signed off during a warranty audit will be subject to chargeback and consideration for enrollment into the Dealer Incomplete Recall Repair Process.

**Note:** Other approvals (electronic or handwritten) for add-on repair lines, dealer owned vehicle repairs, and repeat repairs do not qualify as FSA parts inspection approvals. The post repair FSA parts inspection process (electronic or handwritten) is independent from other warranty approval requirements. The approval by the designated employee implies that the FSA parts were found to be replaced and must be able to be clearly identified on the Repair Order. If multiple FSA's require approval on a single Repair Order, each applicable occurrence will require individual post repair approval by the designated employee.

## CERTAIN 2015-2020 MODEL YEAR F-150 VEHICLES EQUIPPED WITH A POWER RELEASE TAILGATE — UNINTENDED TAILGATE OPENING

### SERVICE PROCEDURE

**NOTE:** For model years 2015-2018, Safety Recall 20S01 (Canada) or Customer Satisfaction Program 20N03 (United States) **MUST** be completed prior to performing this service procedure.

**NOTE:** At the completion of this repair, dealership service management is to provide a copy of the "Customer Information Sheet" and a copy of the "Owner's Manual Addendum" that is posted with this bulletin to the vehicle owner.

**NOTE:** The tailgate is required to perform the repair but does not need to be installed on the vehicle.

1. Lower the tailgate of the vehicle.
2. Open the hood of the vehicle.
3. If equipped, open the roof opening panel.
4. Disconnect the negative battery cable(s) and position aside. Please follow the Workshop Manual (WSM) procedures in Section 414-01.
5. Remove the Body Control Module (BCM). Please follow the WSM procedures in section 419-10.
6. Inspect the BCM for any sign(s) of moisture and/or corrosion. See Figure 1 for examples of corrosion.  
- Was any sign(s) of moisture and/or corrosion present?

Yes - **Photo(s) of BCM water contamination MUST be submitted to the Special Service Support Center (SSSC) prior to continuing with water leak diagnostics.** Then proceed to Step 8.

No - Proceed to Step 7.

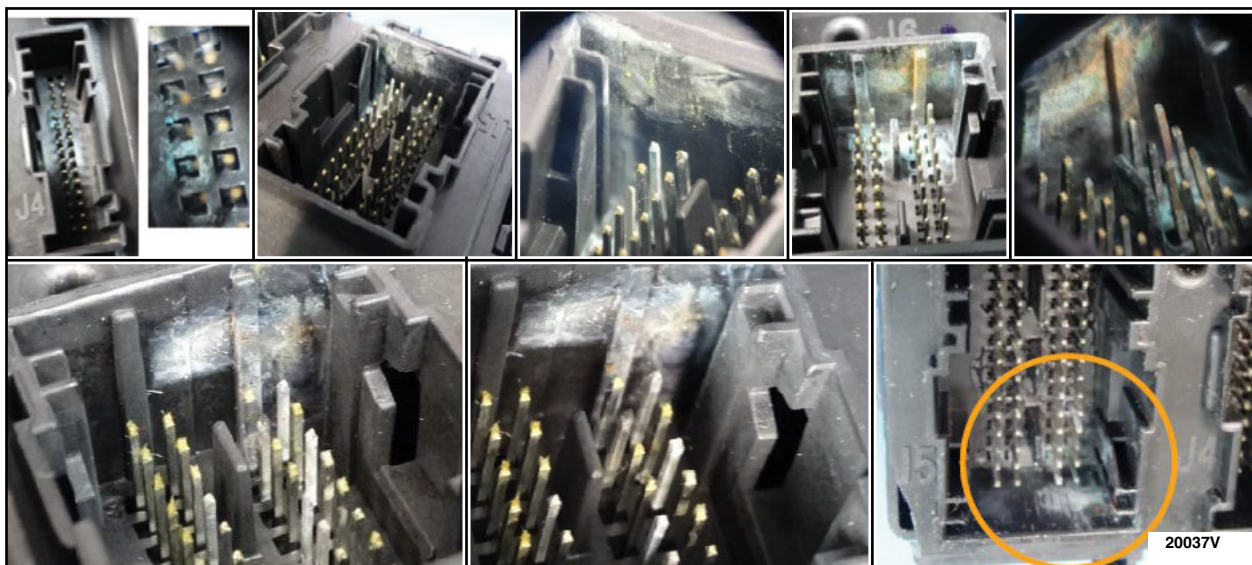

**FIGURE 1**



7. Remove each BCM fuse, one at a time, and inspect for sign(s) of moisture and/or corrosion.

See Figure 2.

- Was any sign(s) of moisture and/or corrosion present?

Yes - **Photo(s) of BCM water contamination MUST be submitted to the SSSC prior to continuing with water leak diagnostics.** Then proceed to Step 8.

No - Proceed to Step 36 (Page 12).

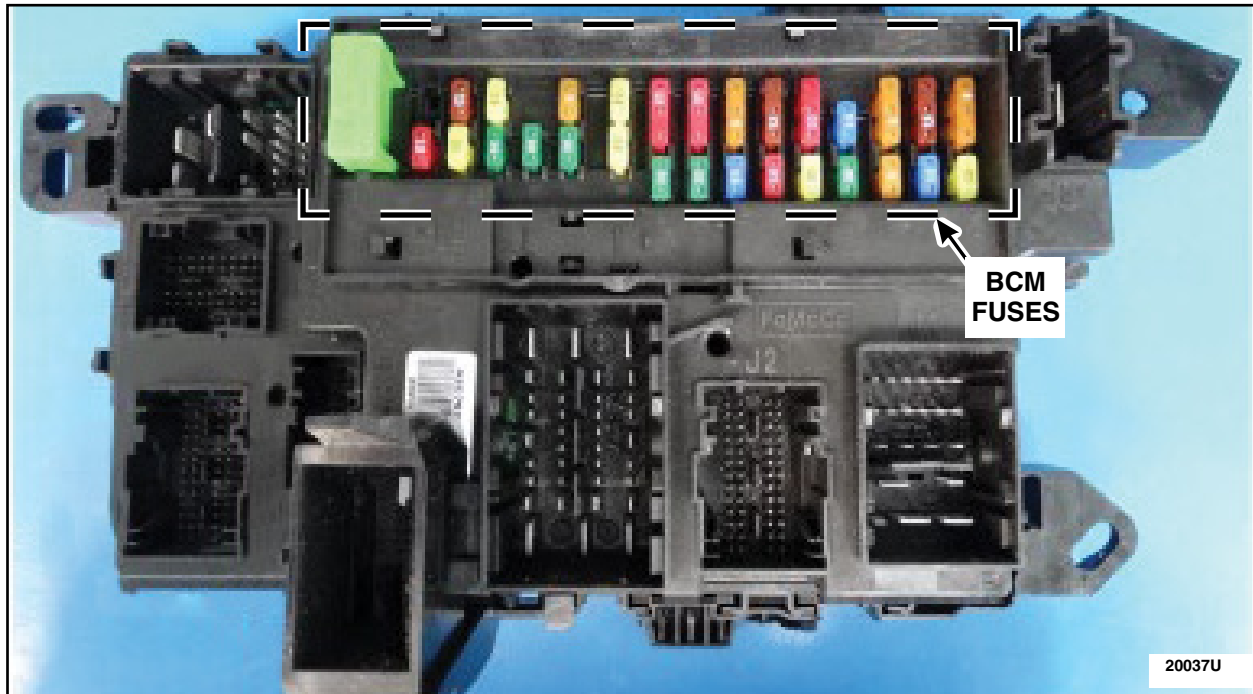

FIGURE 2

8. Is the vehicle equipped with a roof opening panel? See Figure 3.

Yes - Proceed to Step 9.

No - Proceed to Step 19 (Page 6).

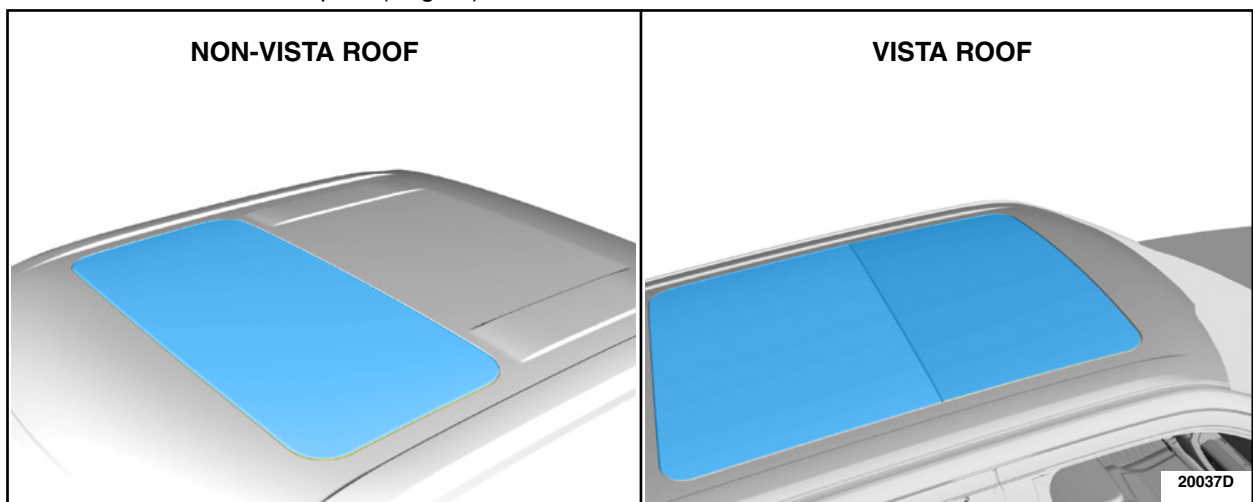
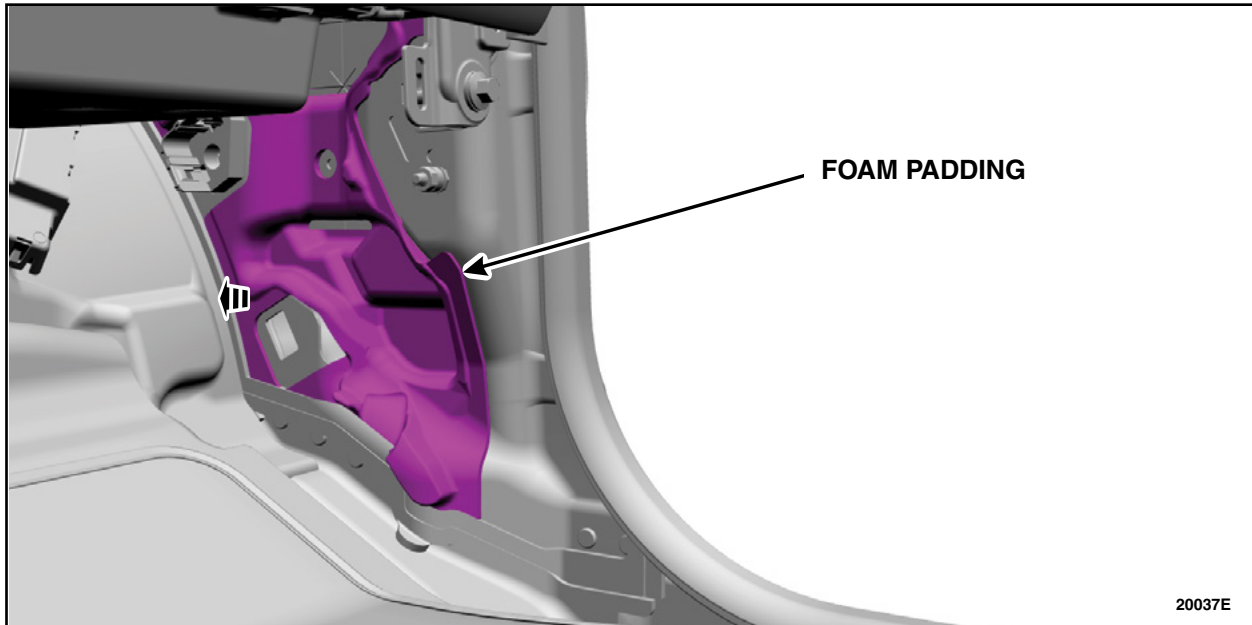

FIGURE 3





9. Remove the foam padding located behind the BCM. See Figure 4.

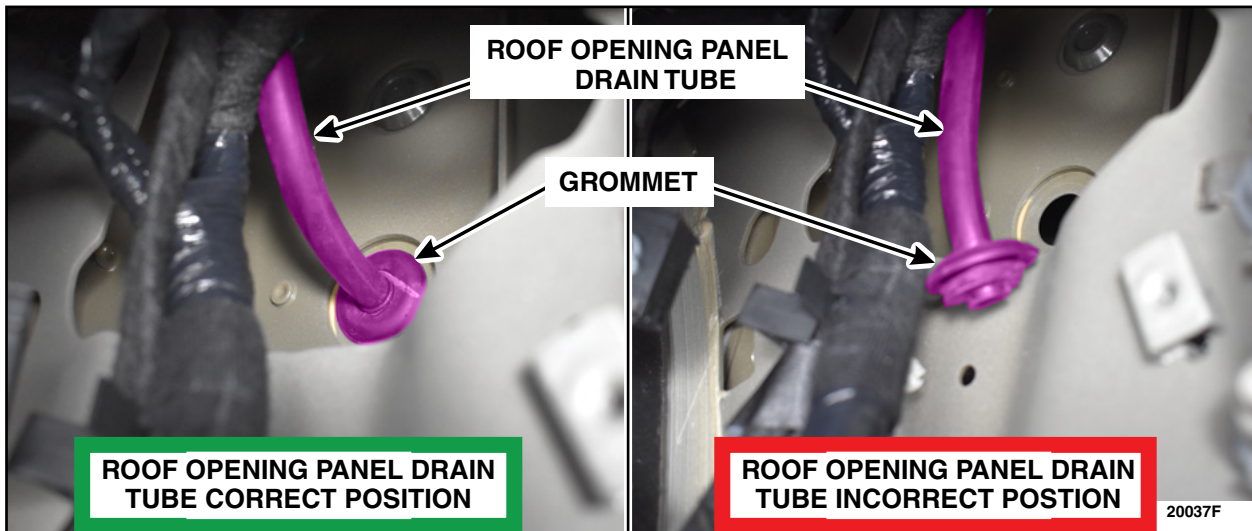

**FIGURE 4**

10. Inspect the roof opening panel drain tube and grommet located behind the BCM area.  
- Is the drain tube and grommet in the correct position? See Figure 5.

Yes - Proceed to Step 17 (Page 6).

No - Proceed to Step 11.



**FIGURE 5**



11. Is the grommet attached to the roof opening panel drain tube as seen in See Figure 6?

Yes - Proceed to Step 12.

No - Proceed to Step 13.

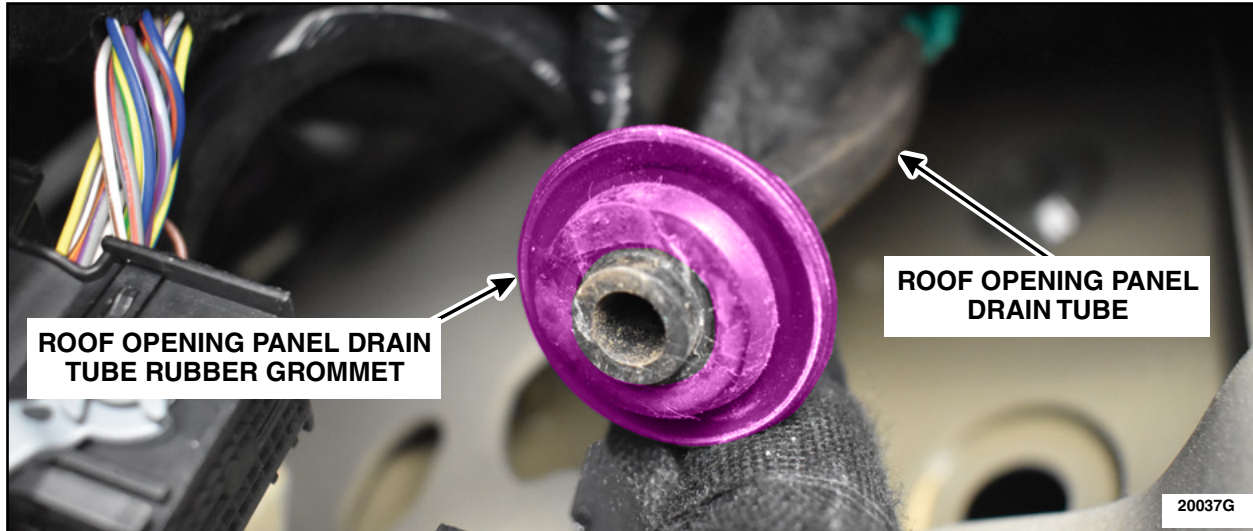

**FIGURE 6**

12. Install the roof opening panel drain tube into the body panel making sure that the grommet is fully seated. Perform a 2-tug test on the roof opening panel drain tube.

- Did the drain tube and grommet remain in place? See Figure 7.

Yes - Proceed to Step 17 (Page 6).

No - Proceed to Step 13.

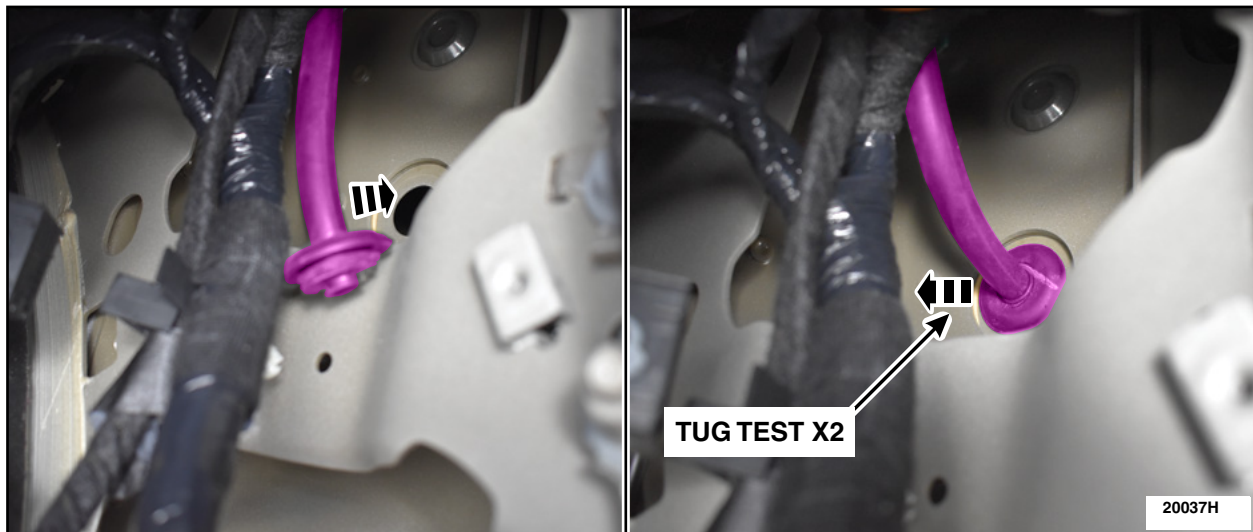

**FIGURE 7**





13. Remove the Right Hand (RH) A-Pillar Trim Panel. Please follow the WSM procedures in Section 501-05.

14. Lower the front RH corner of the headliner. See Figure 8.

**CAUTION:** Do not bend or crease the headliner.

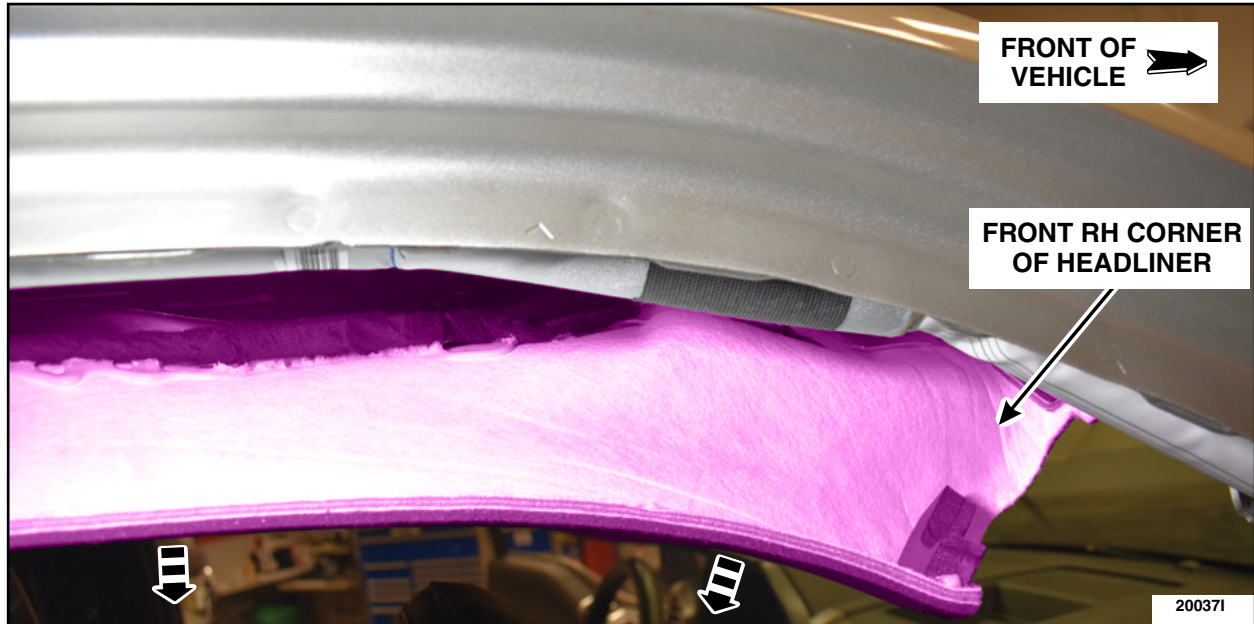

**FIGURE 8**

15. Remove the roof opening panel drain tube. See Figure 9.

1. Remove the drain tube grommet located behind the BCM.
2. Disconnect the drain tube at the roof opening panel.
3. Release the drain tube retainers located along the RH A-pillar down through the Instrument Panel (IP).
4. Remove the drain tube out the top of the IP.

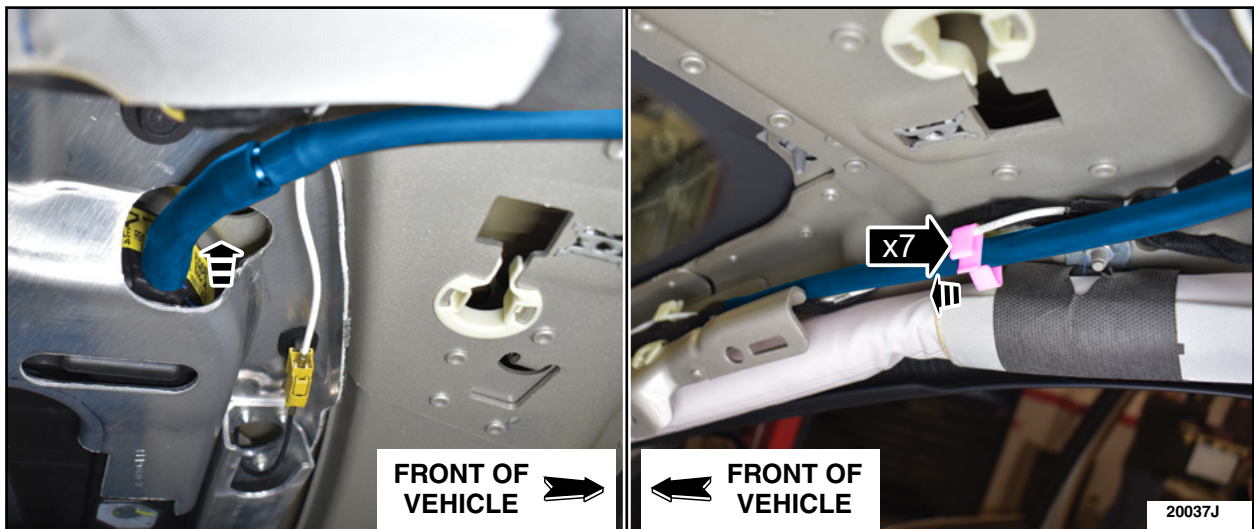

**FIGURE 9**



16. Install a *new* roof opening panel drain tube by reversing Step 15.
17. Pour a glass of water into the roof opening panel drain tube channel and immediately inspect the roof opening panel drain tube grommet for water leakage. See Figure 10.
- Is there water leakage inside the vehicle at the grommet

Yes - Proceed to Step 18.

No- Proceed to Step 19

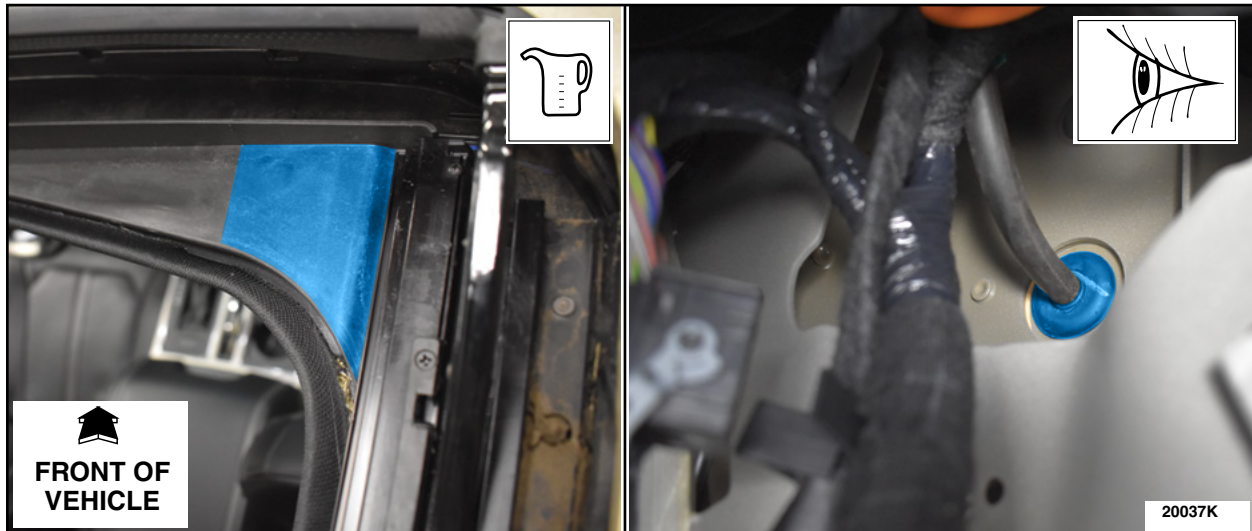

**FIGURE 10**

18. Check that the roof opening panel drain tube rubber grommet is fully seated, then repeat Step 17.
- Is the roof opening panel drain tube rubber grommet fully seated and still leaking after the second inspection?

Yes - Proceed to Step 15.

No - Proceed to Step 19.

19. Using a garden hose, spray the upper RH side of the engine compartment fire wall. See Figure 11.

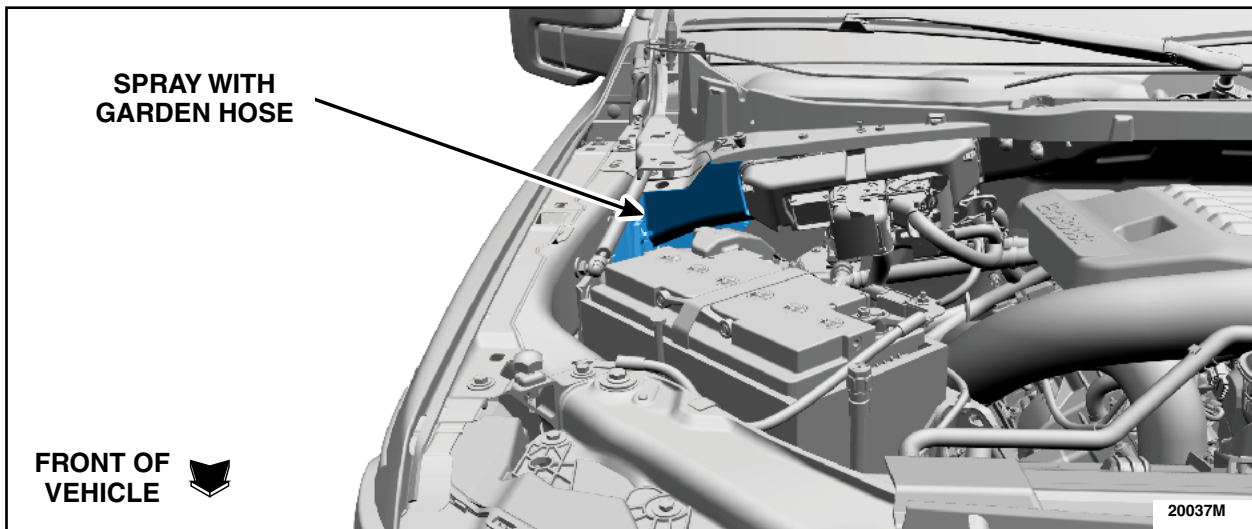

**FIGURE 11**



20. Immediately inspect under the RH side IP, near the BCM, for any sign(s) of water leakage and/or moisture.

- Was any sign(s) of water leakage and/or moisture present?

Yes - Proceed to Step 21.

No - Proceed to Step 24 (Page 8).

21. Remove the Instrument Panel. Please follow the WSM procedures in Section 501-12. Verify the location of the water leak by repeating Step 19.

22. Using Motorcraft® TA-32 Clear Silicone Rubber Sealer or equivalent, apply a bead along the body patch and allow it to dry. See Figure 12. Retest by performing Step 19 once the Clear Silicone Rubber is dry.

- Was any water leakage found after sealant has dried?

Yes - Apply more sealant by performing Step 22.

No - Proceed to Step 23.

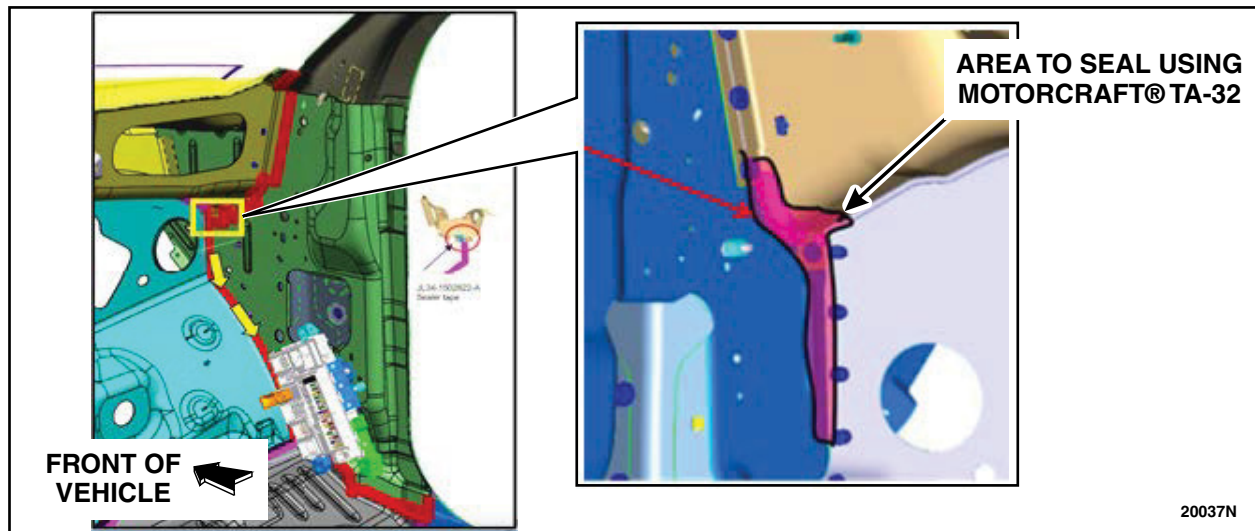

**FIGURE 12**

23. Install the Instrument Panel. Please follow the WSM procedures in Section 501-12.

- Do not install the RH A-pillar trim panel, scuff plate, foam padding or BCM cover at this time.



24. Inspect the front RH side door weatherstrip for any rips or deformity. See Figure 13.  
- Were any rips or deformity present?

Yes - Install a *new* Front Passenger Door Weatherstrip. Proceed to Step 25.  
No - Proceed to Step 25.

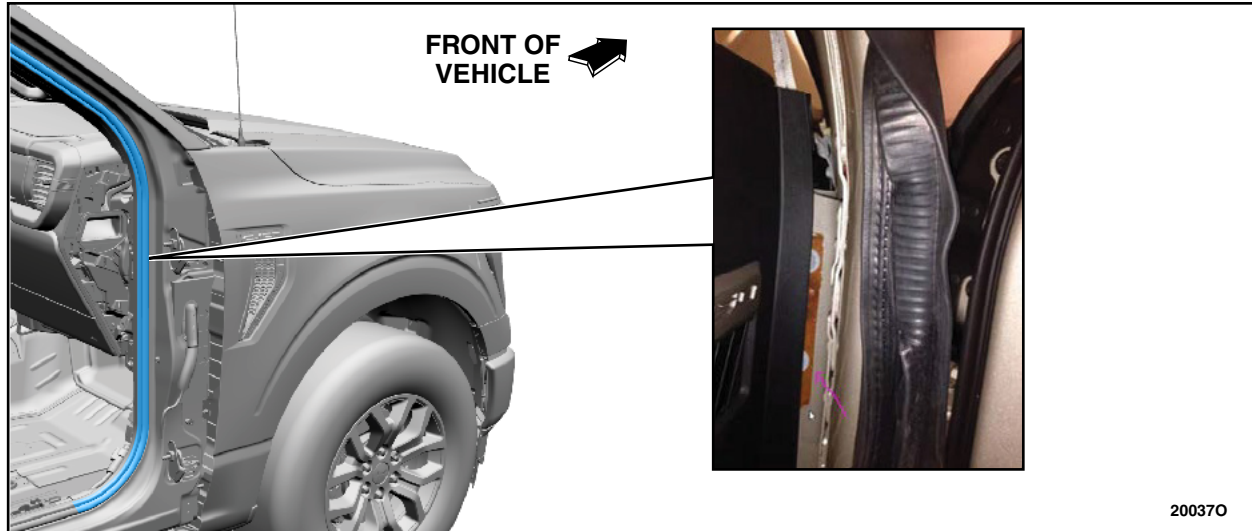

FIGURE 13

25. Using a garden hose, spray down the RH side of the windshield, then immediately inspect the A-pillar area within the vehicle for signs of moisture and/or leakage. See Figure 14.  
- Was any sign of moisture and/or leakage found around the A-pillar?

Yes - Remove, then reseal the windshield. Please follow the WSM procedures in Section 501-11.  
Repeat Step 25.  
No- Proceed to Step 26.

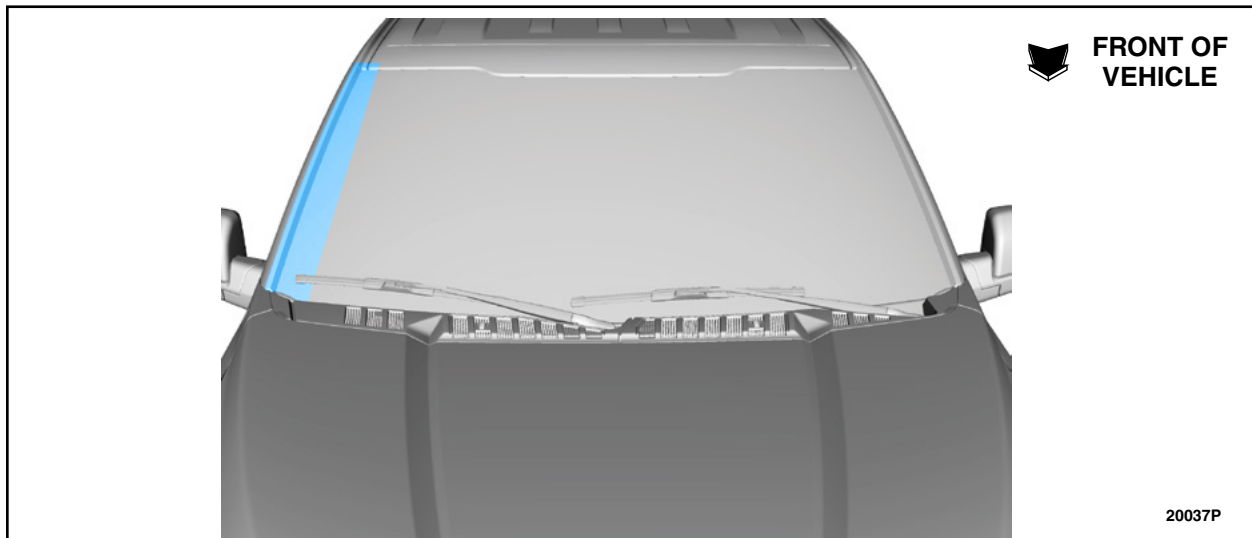

FIGURE 14





26. Using a garden hose, run water over the front RH roof ditch, immediately inspect the A-pillar inside the vehicle for signs of moisture and/or leakage. See Figure 15.

- Was any signs of moisture and/or leakage found around the A-pillar?

Yes - Proceed to Step 27.

No - If equipped with a roof opening panel, Proceed to Step 29.

If NOT equipped with a roof opening panel, Proceed to Step 35 (Page 12).

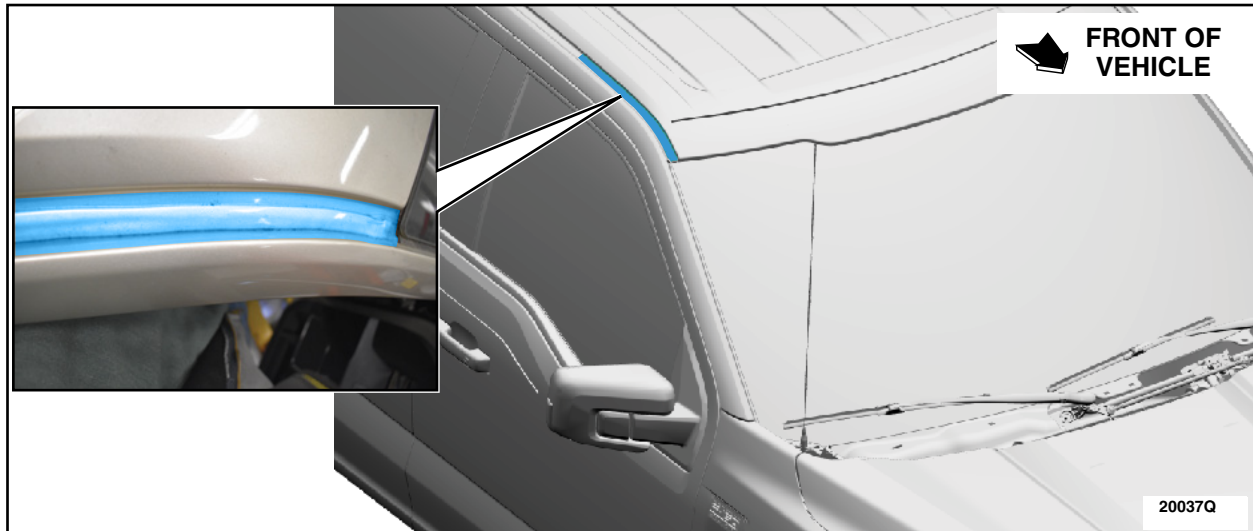

**FIGURE 15**

27. Neatly apply some Motorcraft® TA-32 Clear Silicone Rubber to the front RH roof ditch. See Figure 16. Allow the sealer to cure, then proceed to Step 28.

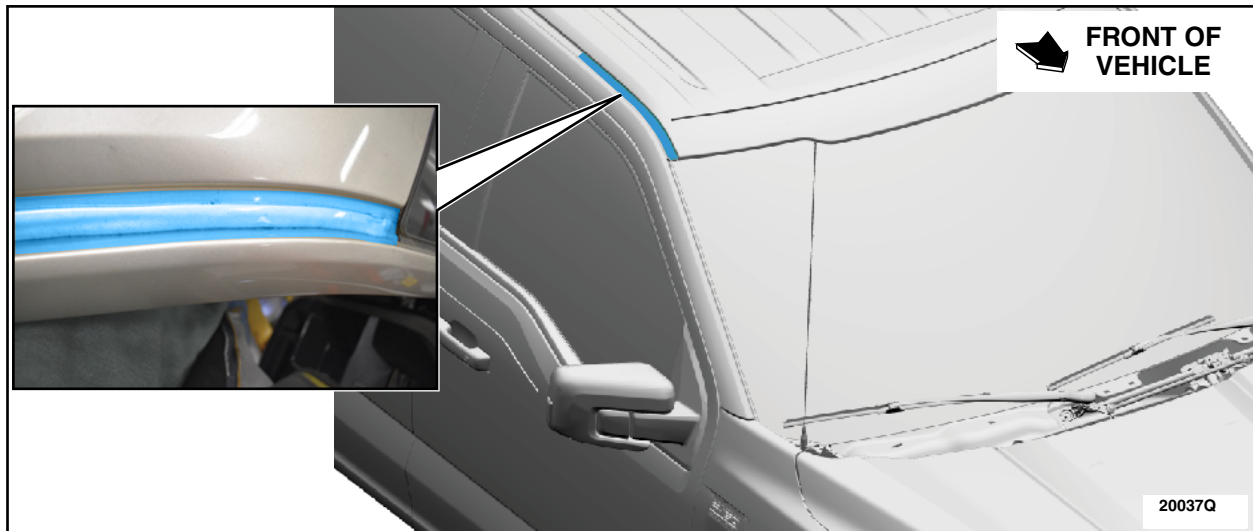

**FIGURE 16**



 **CAUTION:** Do not bend or crease the headliner.

28. Lower the front RH corner of the headliner. See Step 14, Figure 8. Pour a glass of water into the roof opening panel drain tube channel and immediately inspect the drain tube at the roof opening panel for water leakage. See Figure 17.

- Is there water leakage from the roof opening panel drain tube?

Yes - Proceed to Step 29.

No - Proceed to Step 32.

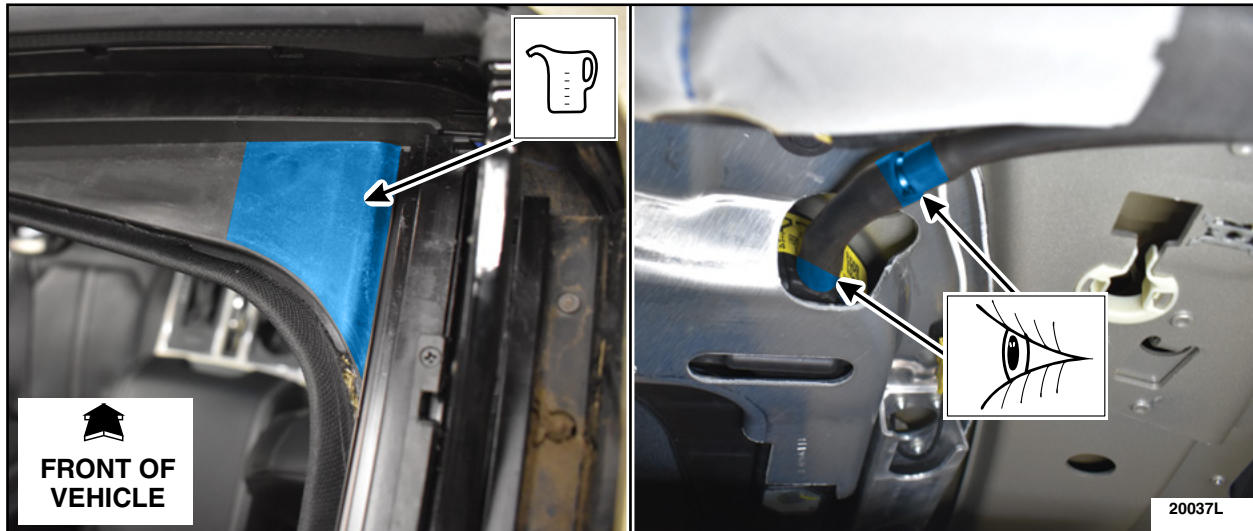

**FIGURE 17**

29. Check that the roof opening panel drain tube is fully seated, then repeat Step 28.

- Is the drain tube fully seated and still leaking after the second inspection?

Yes - Proceed to Step 30.

No - Proceed to Step 32.



30. Remove the roof opening panel drain tube. See Figure 18.

1. Remove the drain tube grommet located behind the BCM.
2. Disconnect the drain tube at the roof opening panel.
3. Release the drain tube retainers located along the RH A-pillar down through the IP.
4. Remove the drain tube out the top of the IP.

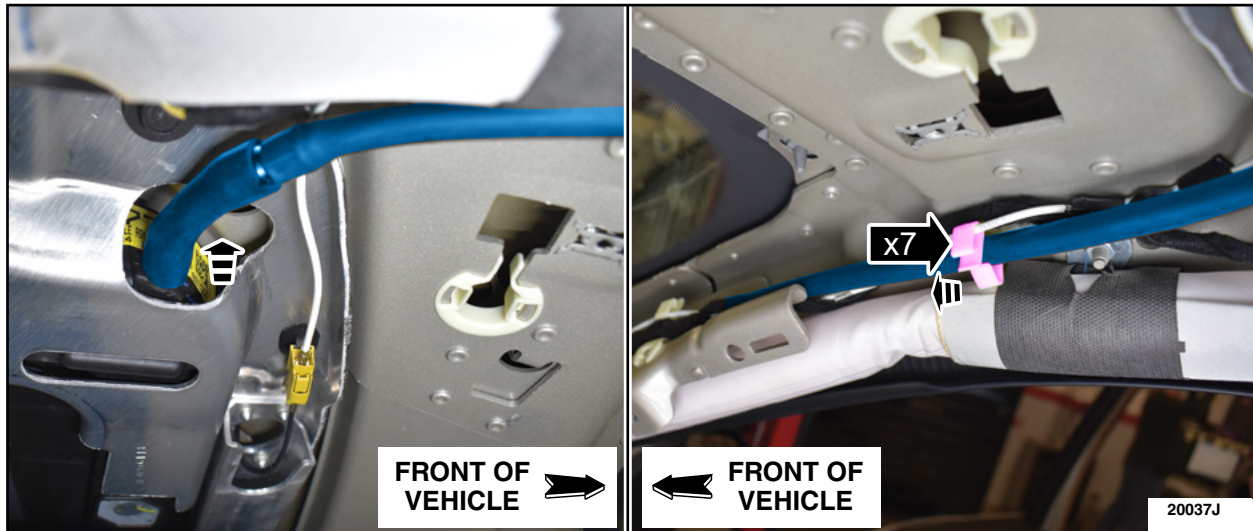

**FIGURE 18**

31. Install a *new* roof opening panel drain tube by reversing Step 30.

32. Position back the front RH corner of the headliner. See Figure 19.

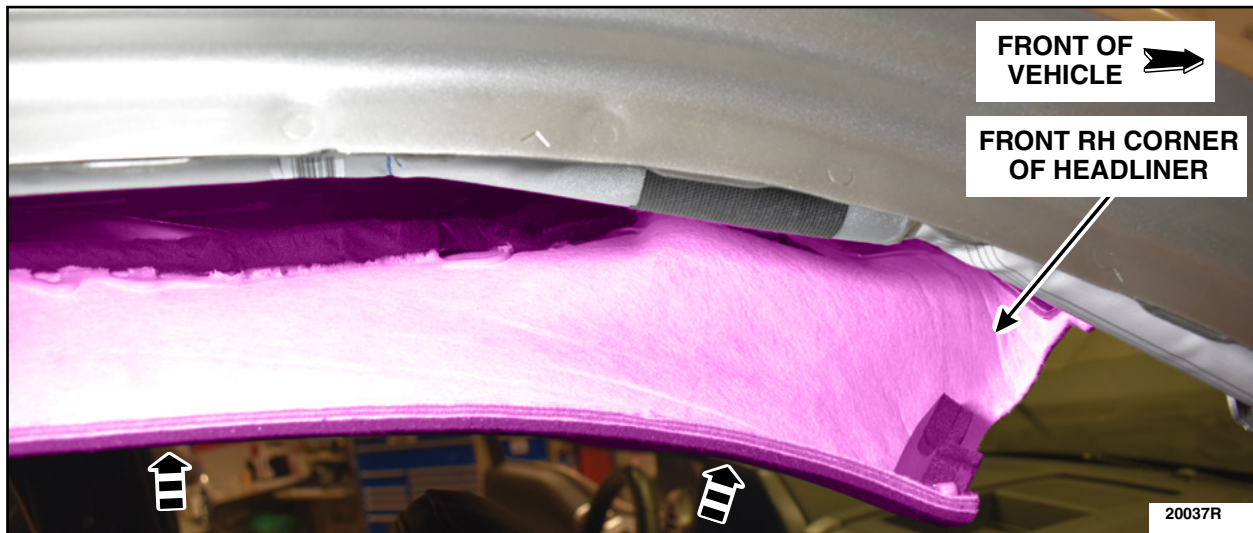

**FIGURE 19**

33. If the previous water leak testing has not been successful in finding the source of the BCM contamination, please refer to WSM procedures under diagnosis and testing found in Section 501-00 to isolate and fix the water leak prior to continue with these instructions.

34. Install the RH A-Pillar Trim Panel. Please follow the WSM procedures in Section 501-05.





35. If the BCM is to be replaced due to corrosion and/or moisture, please follow the WSM procedures in Section 419-10 then transfer all fuses to a *new* BCM.

- Replace any corroded fuses with a *new* one.
- Discard the old BCM.

36. Install the BCM and retainer. See Figure 20.

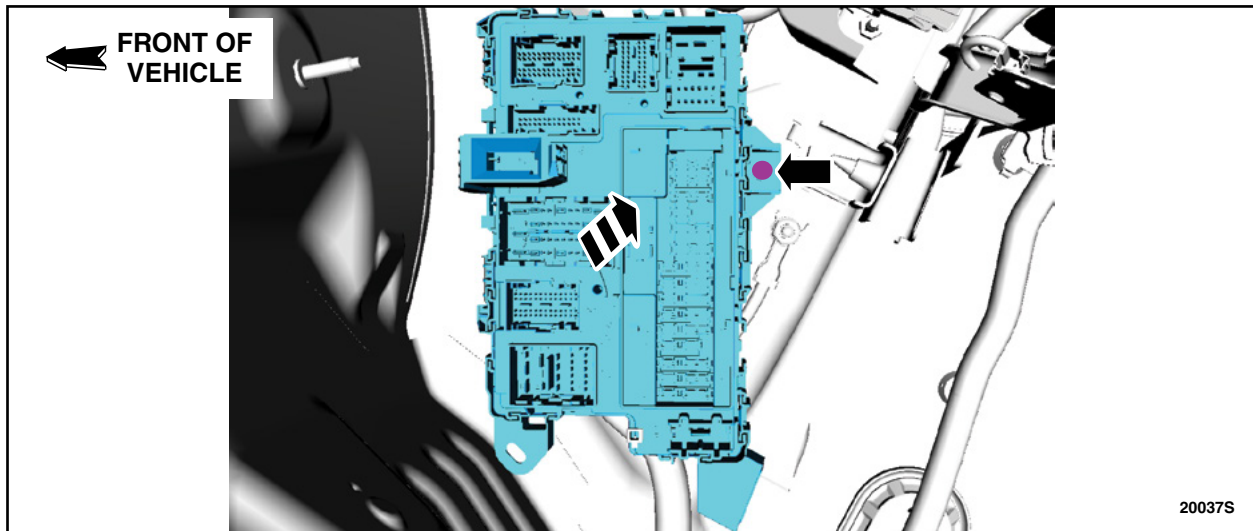

**FIGURE 20**

37. Inspect all the harness side BCM connectors for sign(s) of moisture and/or corrosion.  
- Was any moisture and/or corrosion present?

Yes - For moisture ONLY - Blow dry the affected connector(s) and reconnect the BCM electrical connectors, then proceed to Step 38.

For corrosion - Order and install the appropriate terminal kit(s) for the affected terminal(s), reconnect the BCM electrical connectors, and then proceed to Step 38.

No - Reconnect the connectors to the BCM, then proceed to Step 38.



**Complete Tailgate Actuator Ground Wiring Part Kit**

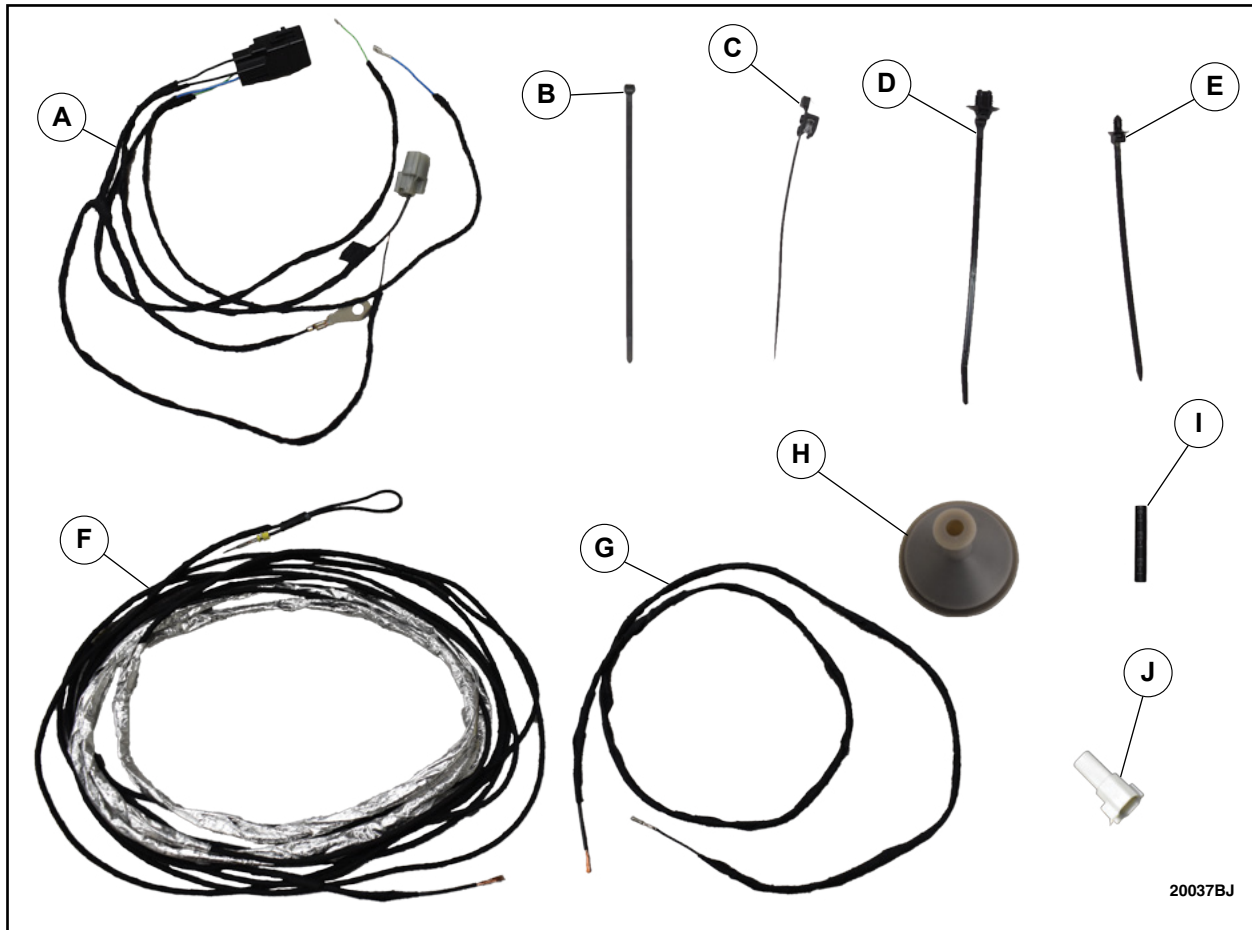

**FIGURE 21**

ITEM	DESCRIPTION	QUANTITY
A	Relay Harness	1
B	Tie Strap	-
C	Edge Biter Style Tie Strap	-
D	Oval Push Pin Style Tie Strap	-
E	Round Push Pin Style Tie Strap	-
F	Body Length Jumper Harness	1
G	Tailgate Jumper Harness	1
H	Grommet	1
I	Heat Shrink Tubing	-
J	Male end 2 Pin Connector	1

**NOTE:** The parts being installed in this procedure are not labeled. Refer to Figure 21 for component identification.



**NOTE:** Wire colors may vary due to substitutions at the harness kit manufacturer.

**NOTE:** Some portions of the rework may have been done at the assembly plant. Move on to the next step.

38. Position aside the weatherstrip, release the clips and remove the RH instrument panel finish panel.  
See Figure 22.

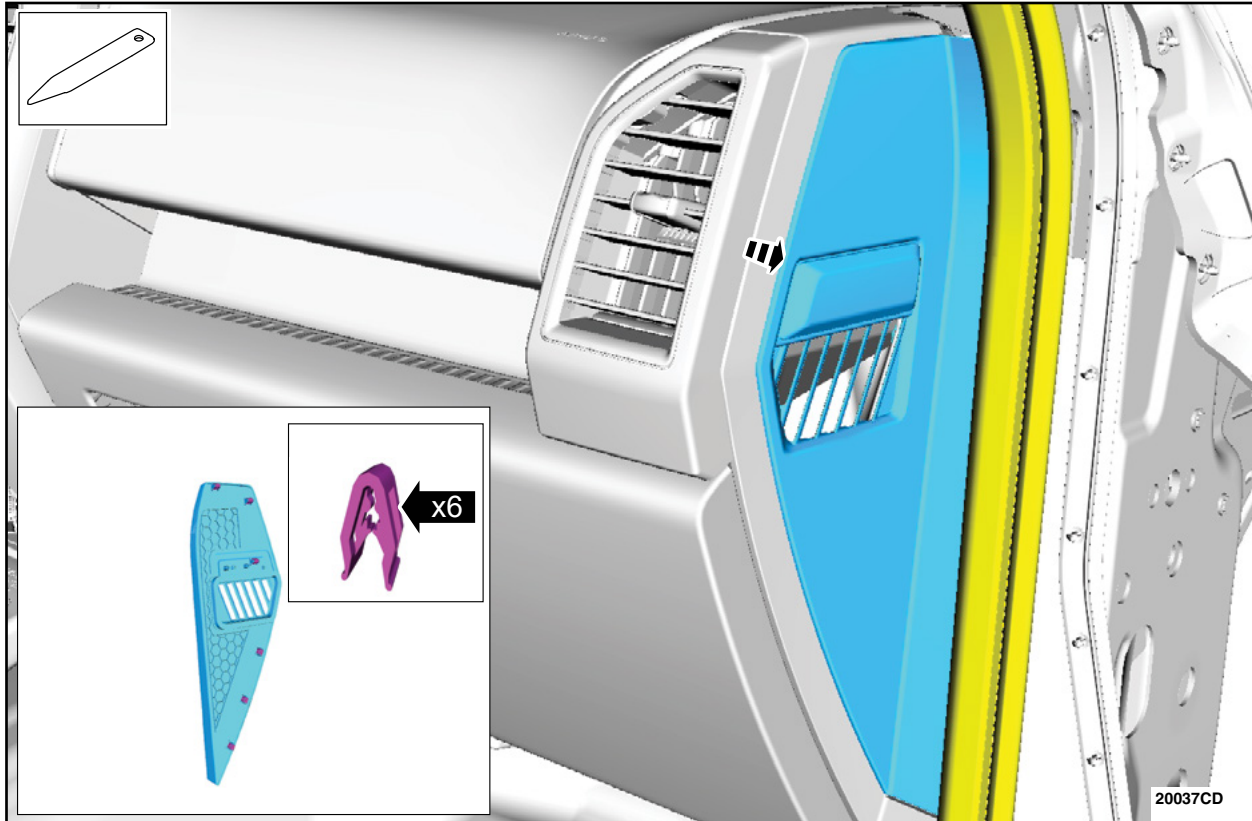

**FIGURE 22**

39. Remove the glove compartment. Please follow the WSM procedures in Section 501-12.



40. Place the relay, included in the kit, onto the instrument panel wiring harness and secure using a tie strap. See figure 23.

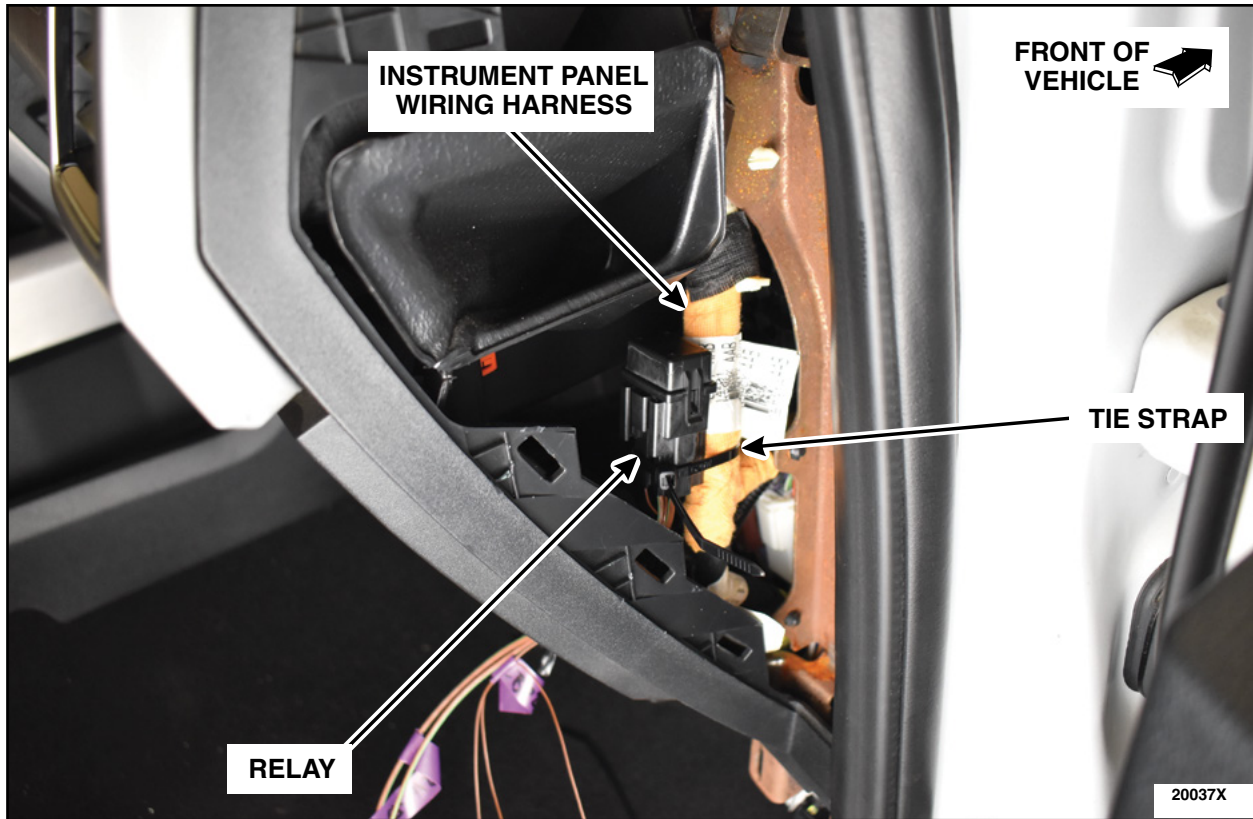

FIGURE 23





**CAUTION:** Do not over torque the ground stud nut.

41. Remove the ground nut, install the ground wire with the eyelet from the relay on to the ground stud. Reinstall the ground stud nut. See Figure 24.

- Torque: 70 lb. in (8 Nm)

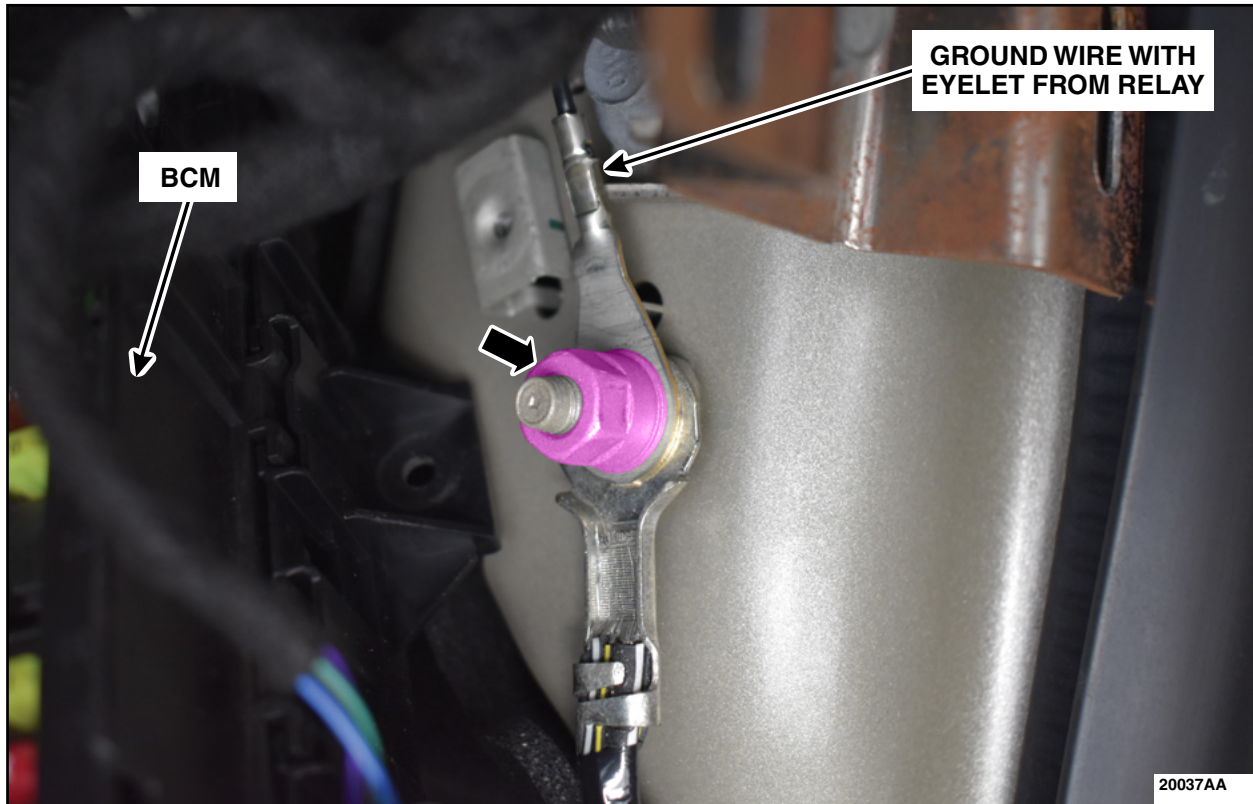

FIGURE 24

42. Disconnect BCM C2280A. See Figure 25.



FIGURE 25



43. Remove the tie strap, black cover and the red locking tab of C2280A. See Figure 26.

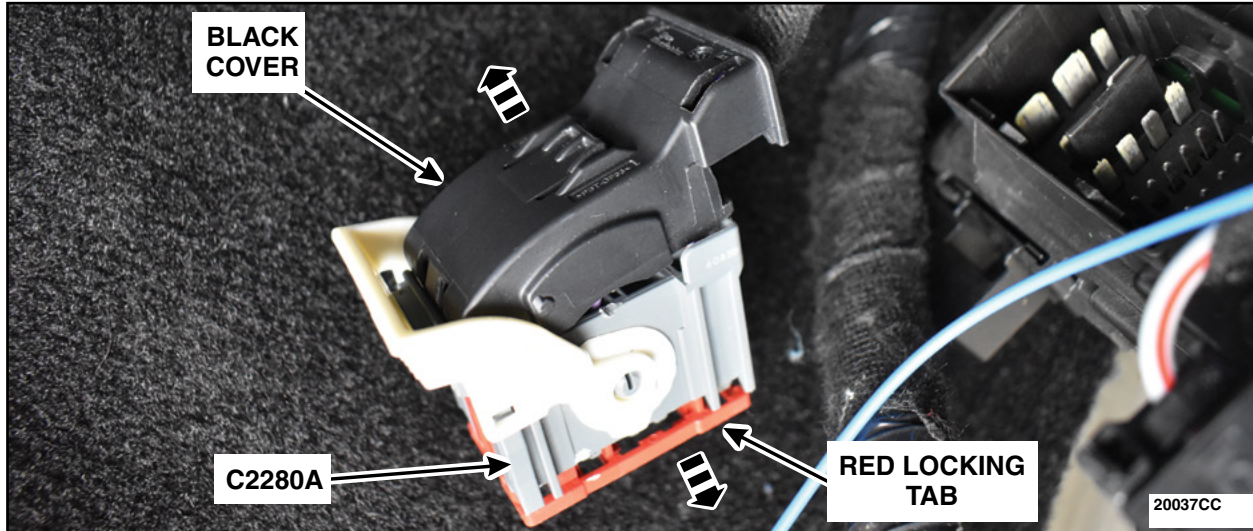

**FIGURE 26**

44. Is pin 16 of C2280A open or occupied with an existing wire?

If OPEN - Proceed to Step 49.

If OCCUPIED - Proceed to Step 45.

45. Remove the wire from pin 16 from C2280A. See Figure 27.

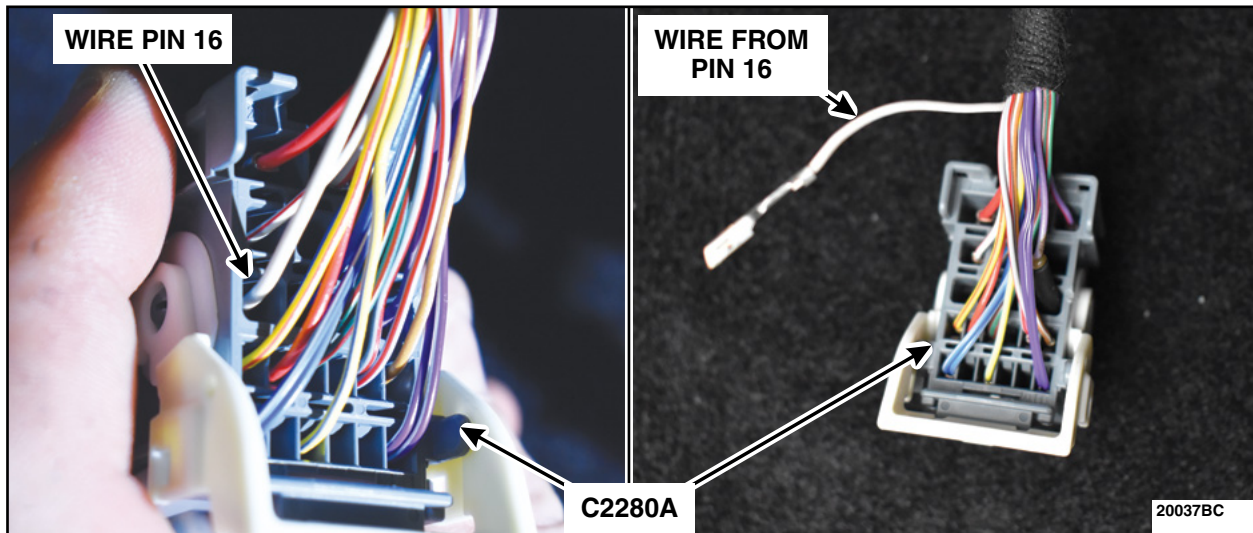

**FIGURE 27**





46. Remove and discard the terminal on the Blue (BL) wire from the relay. On the wire removed from C2280A pin 16, create an inline splice and wrap the BL wire around the inline splice. See Figure 28.

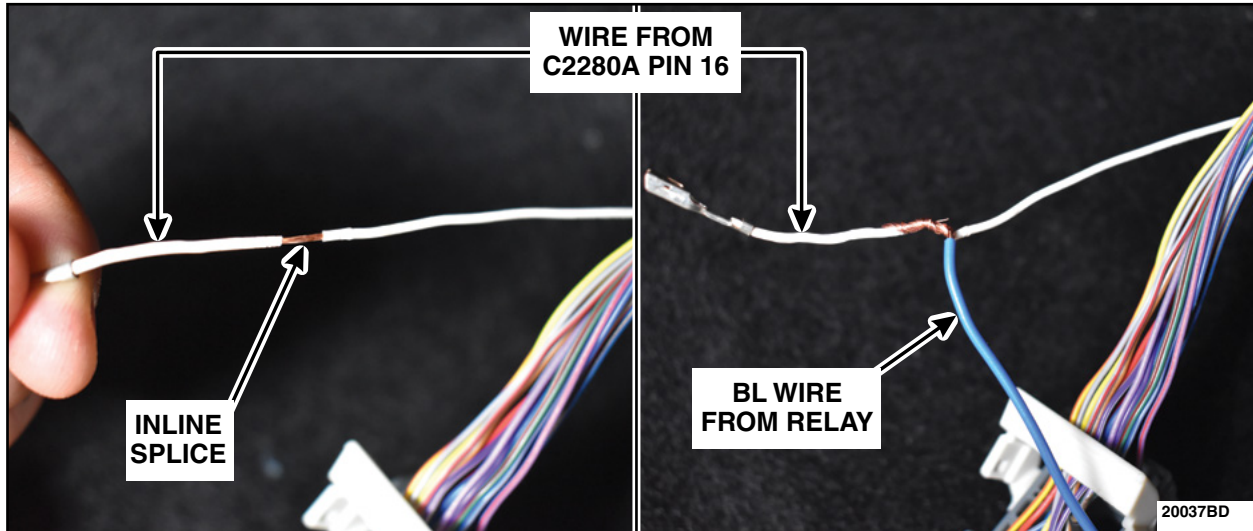

FIGURE 28

47. Solder the BL wire from the relay to the inline splice. Install heat shrink tubing over the inline splice. See Figure 29.

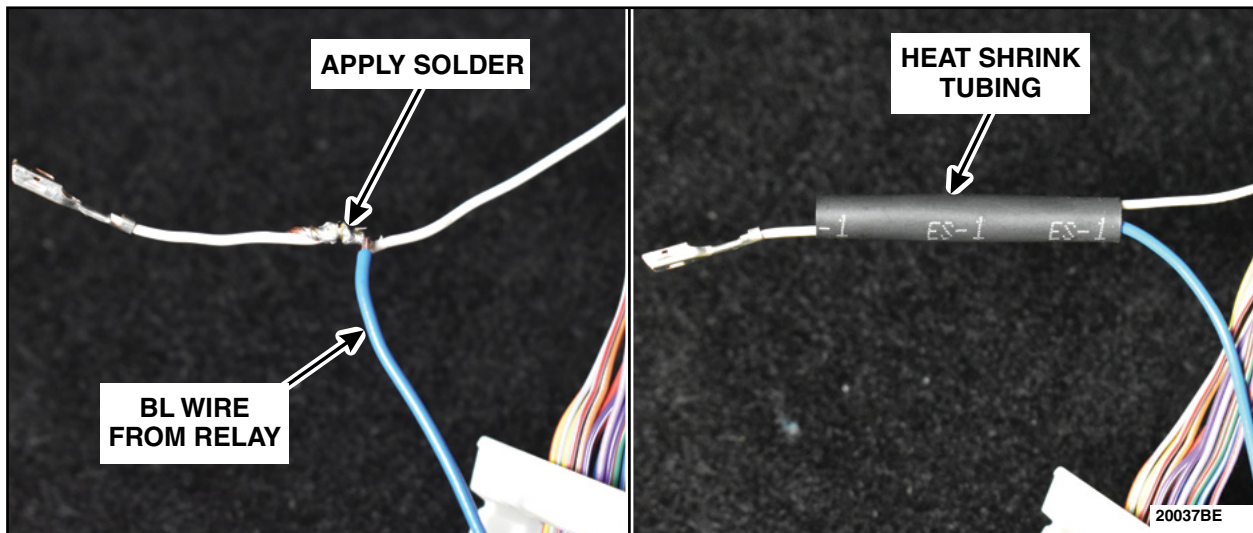

FIGURE 29





48. Apply heat to the heat shrink tubing to seal the inline splice. Reinstall the wire into pin 16 of C2280A. See Figure 30. Proceed to Step 50.

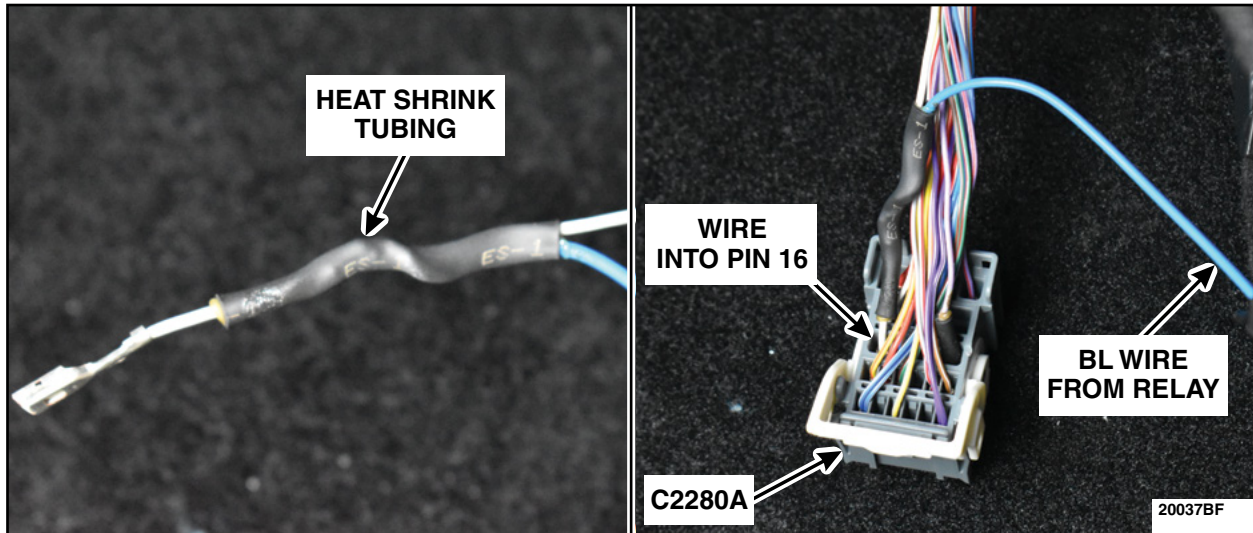

FIGURE 30

49. Install the BL wire from the relay into the open pin 16 of C2280A. See Figure 31.

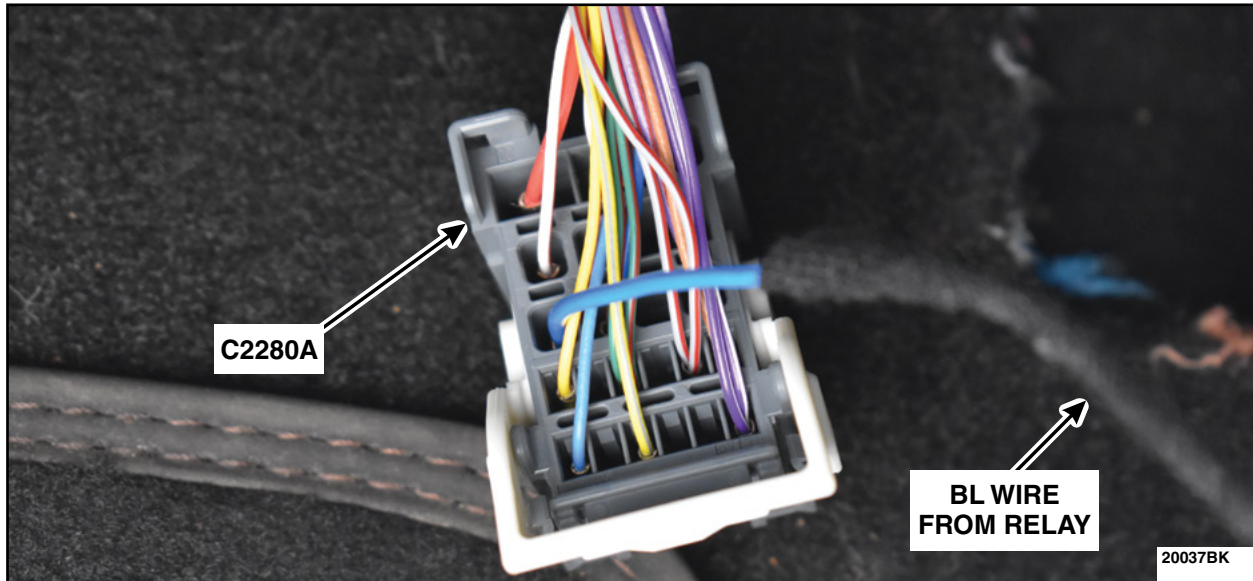

FIGURE 31



50. Reinstall the red locking tab and the black cover. Secure using a tie strap. See Figure 32. Reconnect C2280A to the BCM.

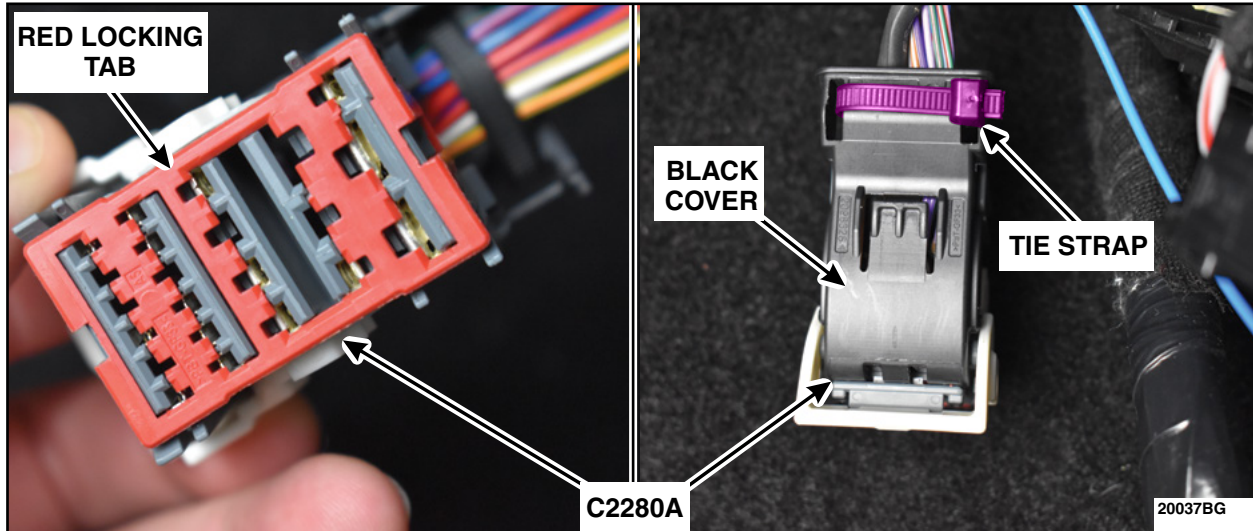

FIGURE 32

51. Disconnect C2280B. See Figure 33.

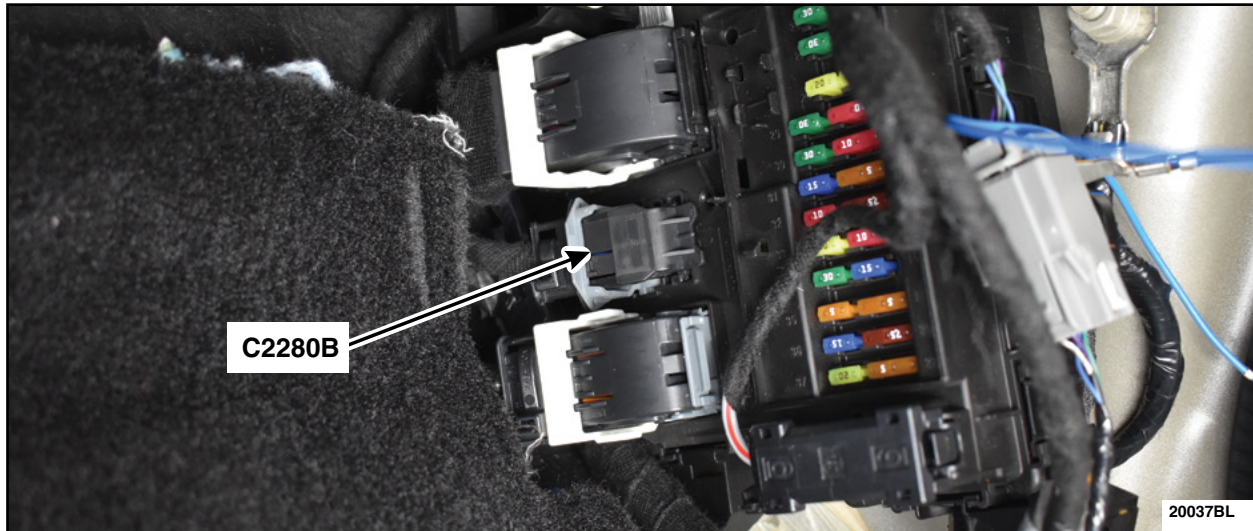
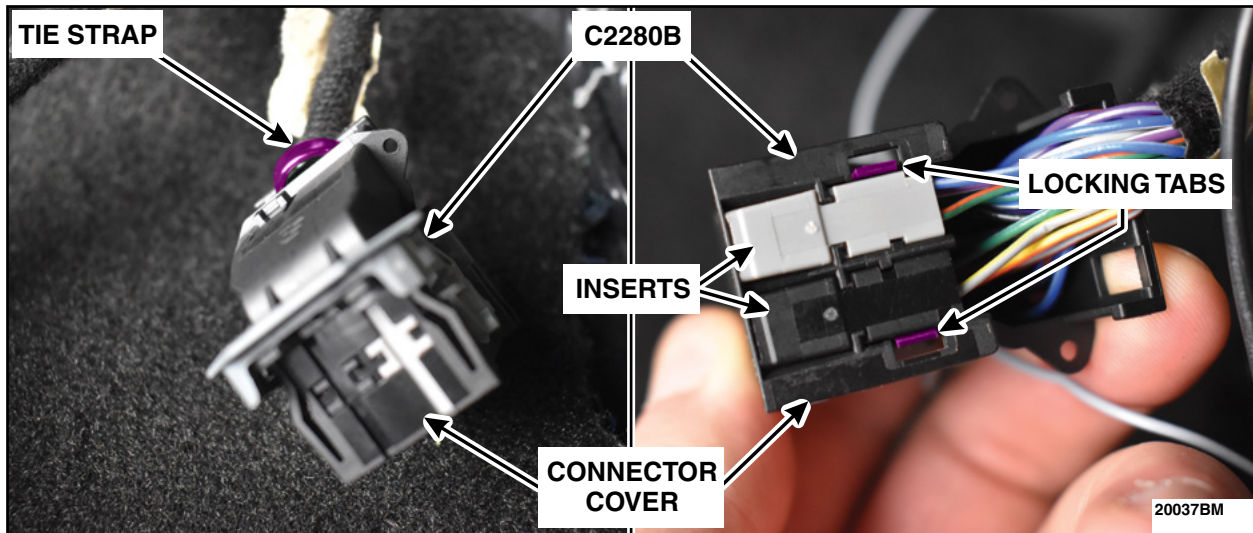

FIGURE 33





52. Remove the tie strap, release the locking tabs and remove the inserts from the connector cover.  
See Figure 34.

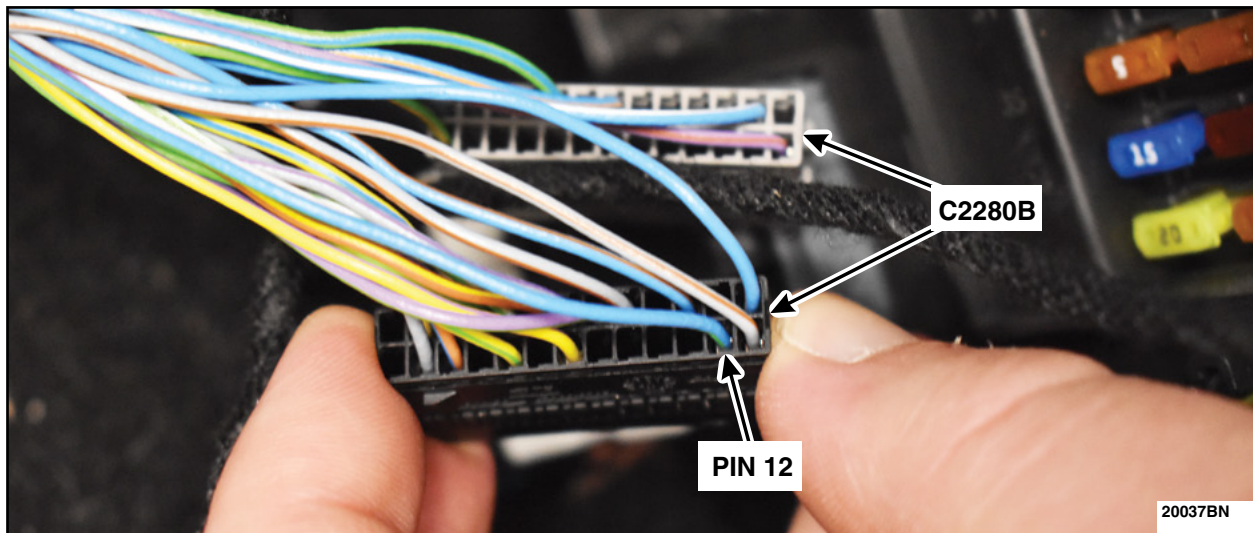

**FIGURE 34**

53. Is pin 12 of C2280B open or occupied with an existing wire? See Figure 35.

If OPEN - Insert the Green (GN) wire from the relay into pin 12, then proceed to Step 58.  
If OCCUPIED - Proceed to Step 54.

**NOTE:** Pin 12 occupied shown.



**FIGURE 35**



54. Measure and cut the pin 12 wire 76 mm (3 in) from the back of the black C2280B. See Figure 36.

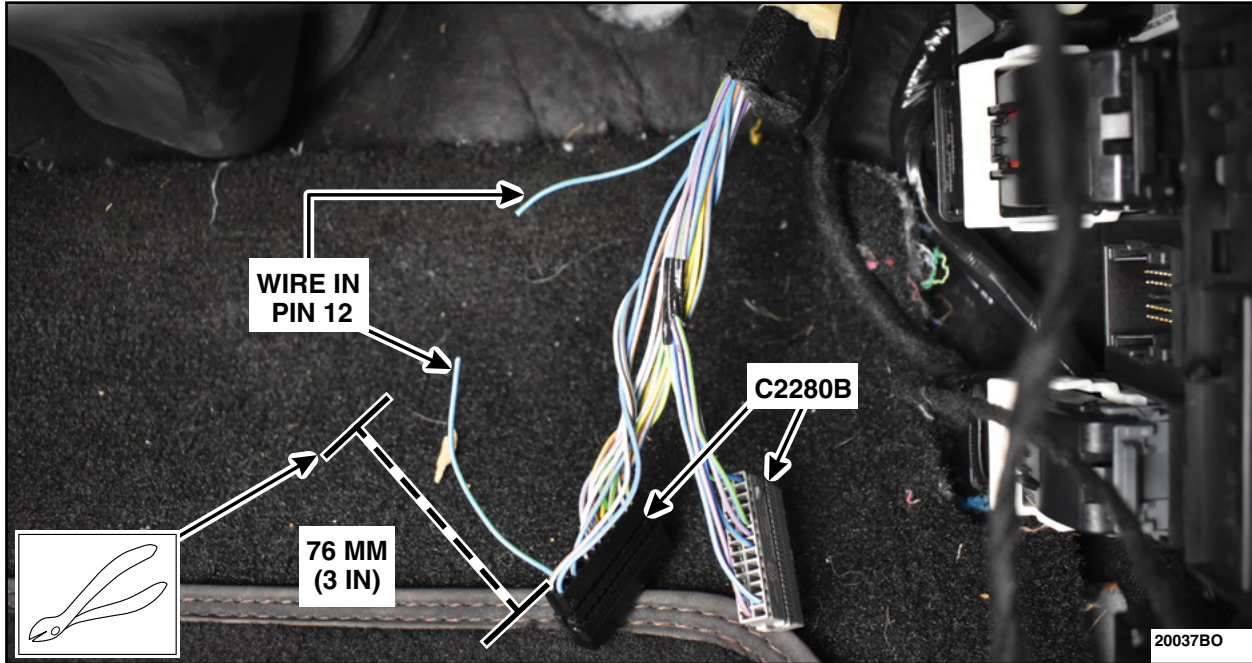

FIGURE 36

55. Strip both ends of the cut wire from pin 12. See Figure 37.

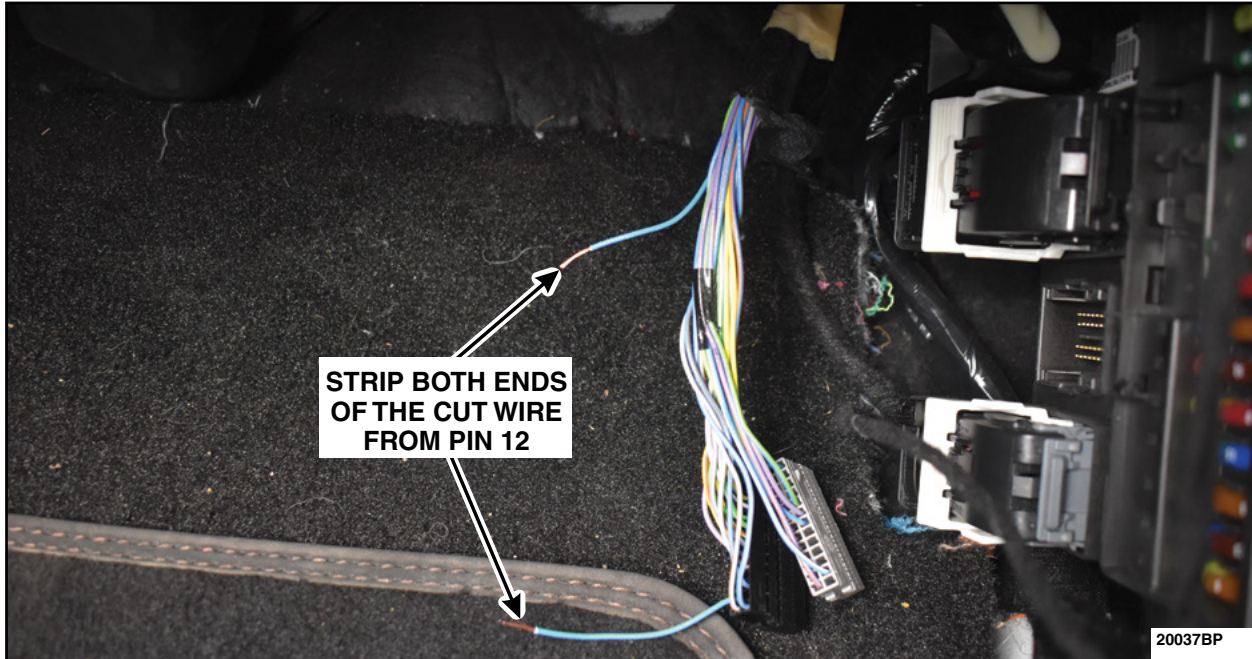

FIGURE 37





56. Cut off and discard the terminal of the Green (GN) wire from the relay. See Figure 38.

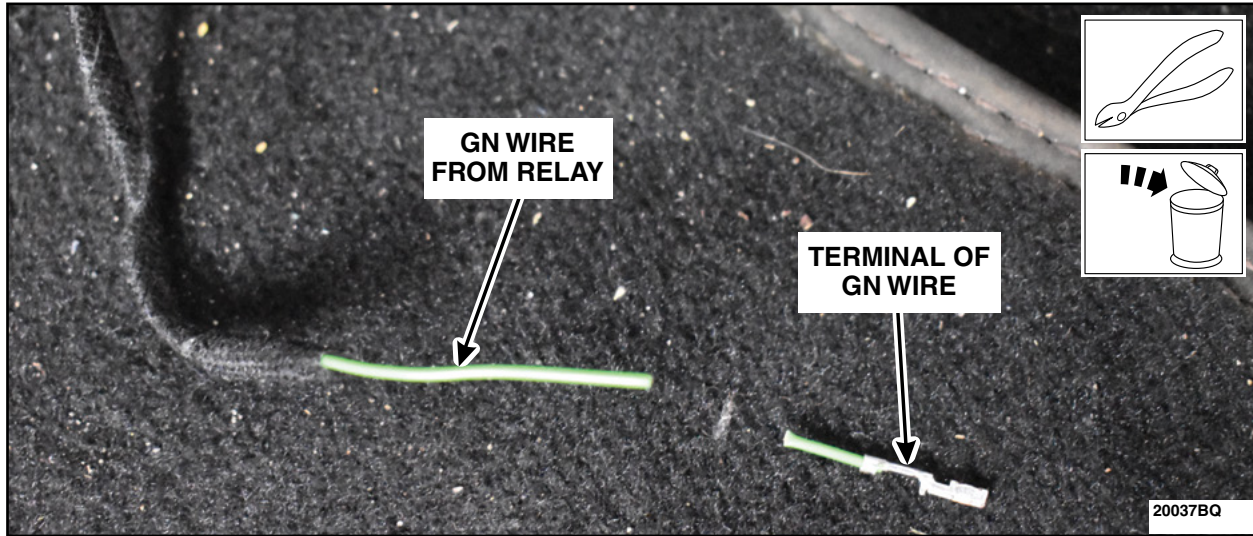

FIGURE 38

57. Apply heat shrink tubing to the BK and GN wires from the relay. Twist the BK wire from the relay to the harness end of the cut wire from pin 12. Twist the BK wire from the relay to the connector end of the cut wire from pin 12. Solder the twisted wires and seal the solder connection with the heat shrink tubing. See Figure 39. Proceed to Step 59.

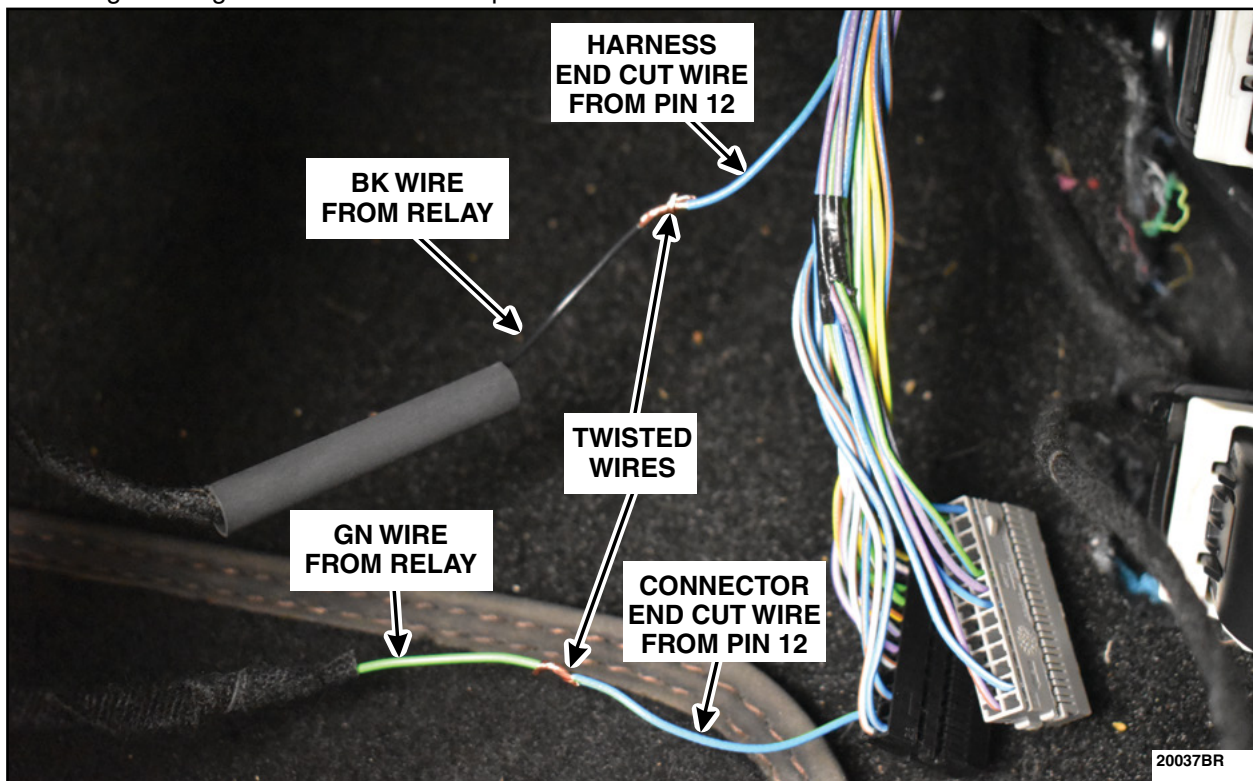

FIGURE 39



58. Locate the Black (BK) wire from the relay. Apply heat shrink tubing and seal the end of the BK wire. Wrap the wire up and secure it to the relay using electrical tape.
59. Reinstall the inserts into the connector cover. Secure using a new tie strap and trim any excess. See Figure 40. Reconnect C2280B to the BCM.

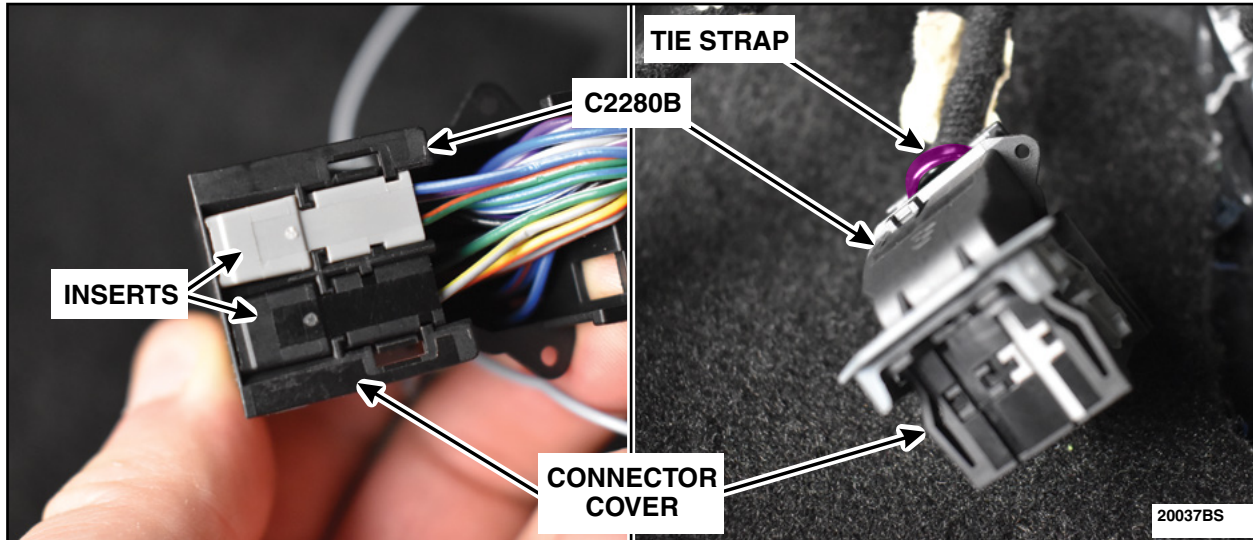

FIGURE 40

60. Position aside the RH front carpet to expose the floorboard. Use a block of wood or similar device to retain the carpet away from the area to be clear of obstruction. See Figure 41.

**CAUTION:** The area highlighted below should be kept clear from obstruction to avoid any damage to carpeting and/or wiring.

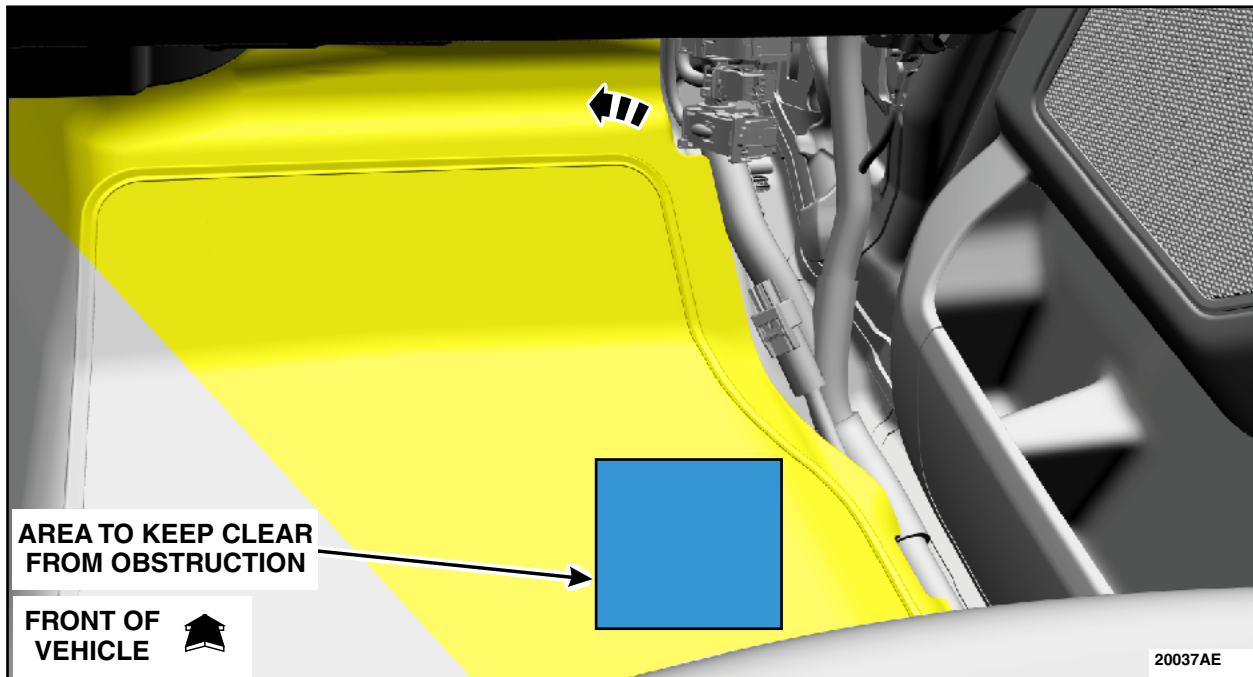

FIGURE 41



61. If equipped, remove the bedliner tailgate cover. See Figure 42.

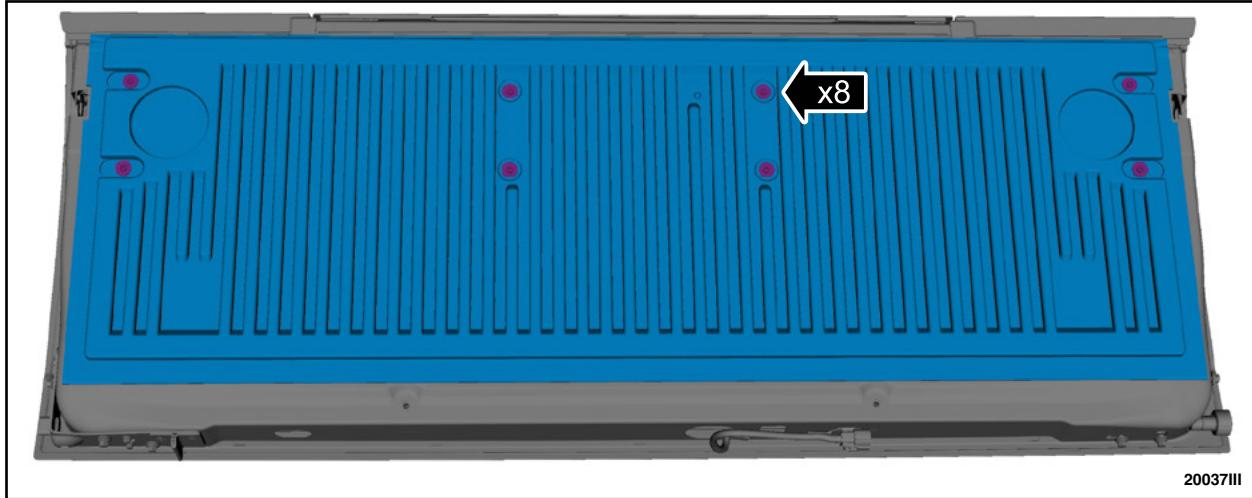

FIGURE 42

62. If equipped, remove the tailgate access panel bolts and the tailgate access panel. See Figure 43.

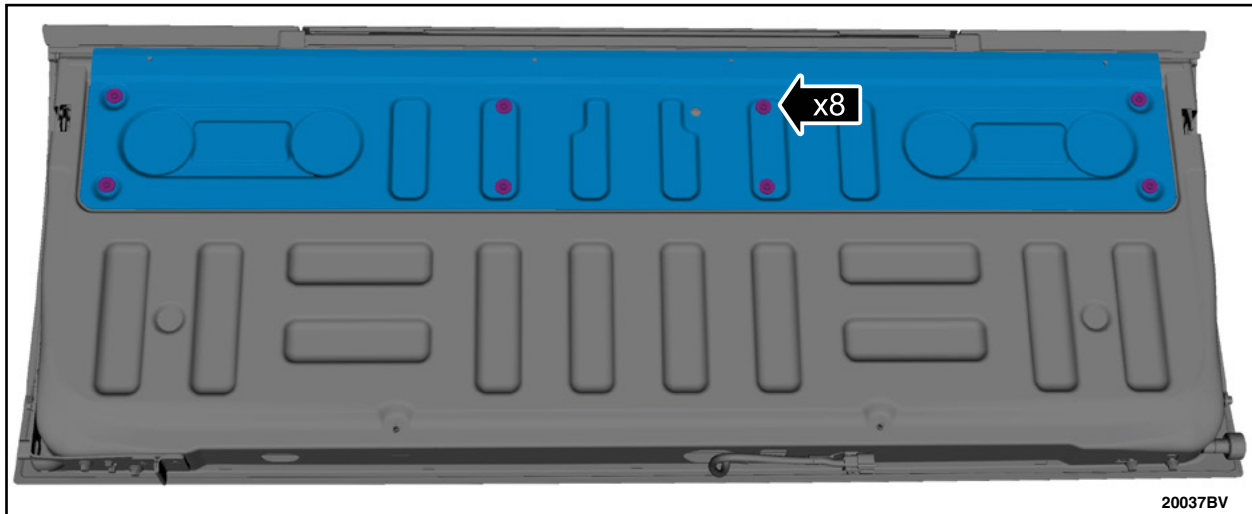

FIGURE 43





63. Remove the tailgate latch control assembly nuts and position the tailgate latch control assembly towards the rear of the vehicle. See Figure 44.

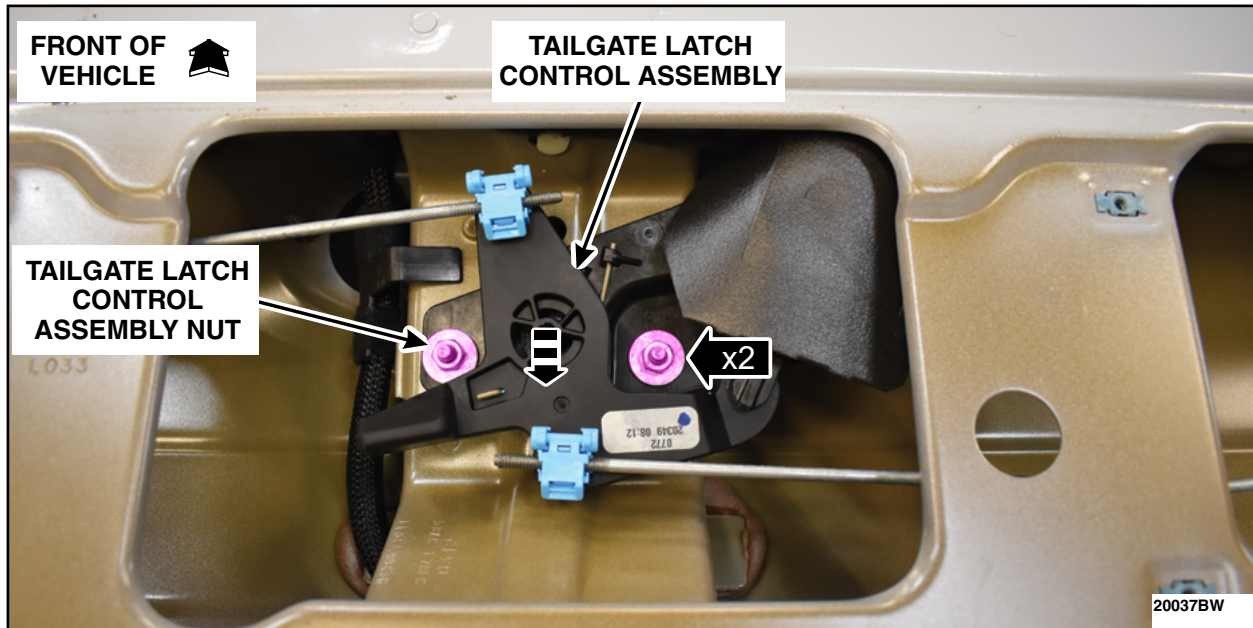

FIGURE 44

64. Disconnect the electrical connector and the push pin retainer. See Figure 45.

**NOTE:** Tailgate latch control assembly shown outside of the vehicle for clarity.

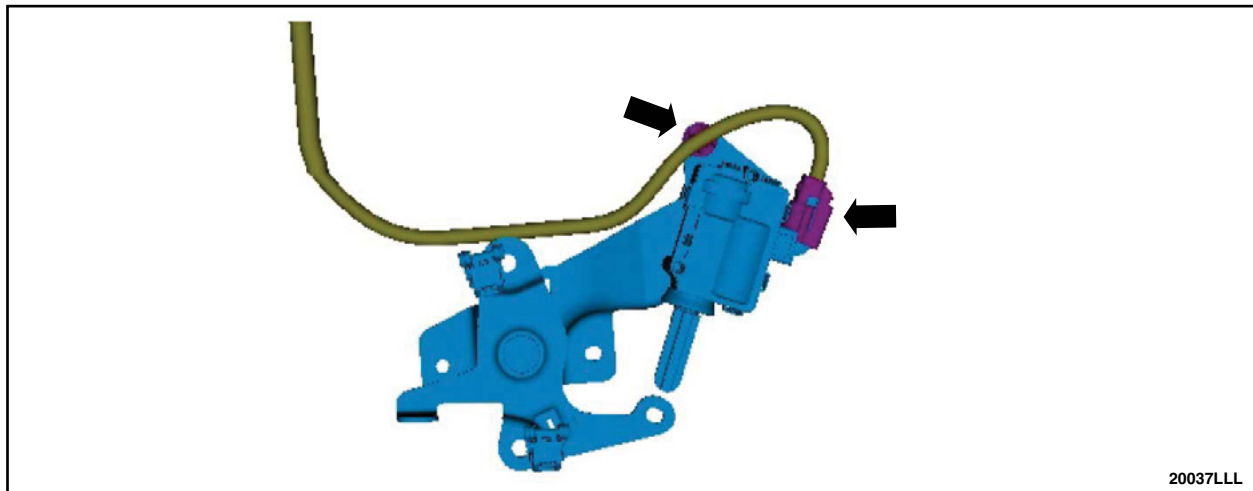
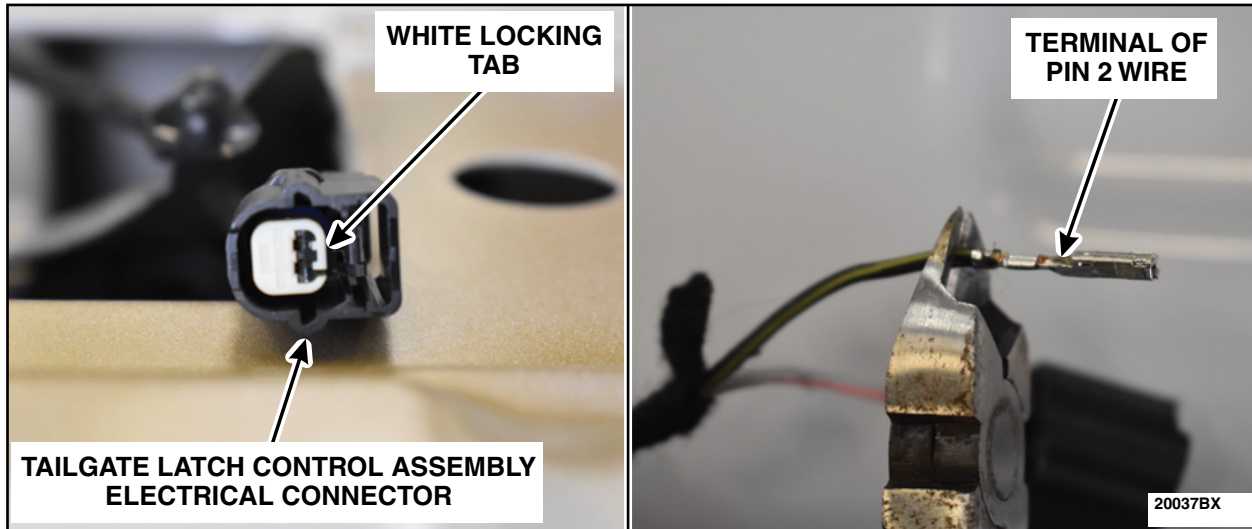

FIGURE 45



65. Remove the white locking tab and the pin 2 wire from the tailgate latch control assembly connector. Cut off the terminal of the pin 2 wire. See Figure 46.



**FIGURE 46**

66. Seal the pin 2 wire using heat shrink tubing. Bend back the sealed wire and secure using Coroplast® 837 or Equivalent Electrical Wire Harness Tape. See Figure 47.

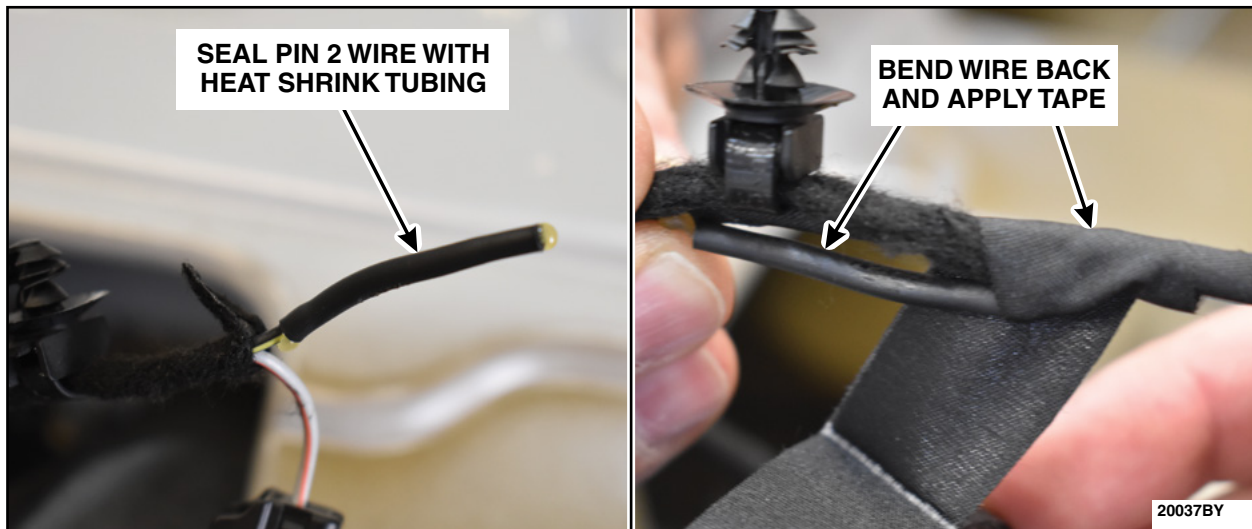

**FIGURE 47**



67. Install the terminal end of the Tailgate Jumper Harness into the open pin in the tailgate latch control assembly electrical connector. Secure using Coroplast® 837 or Equivalent Electrical Wire Harness Tape. Reinstall the white locking tab. See Figure 48.

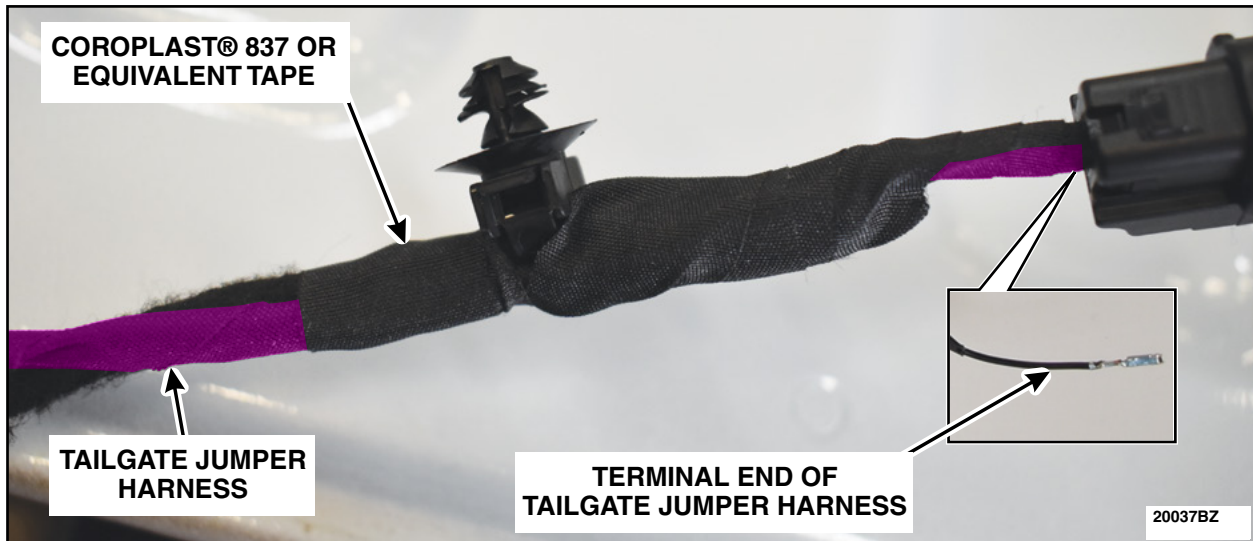

FIGURE 48

68. Reconnect the electrical connector and the push pin retainer. See Figure 49.

**NOTE:** Tailgate latch control assembly shown outside of the vehicle for clarity.

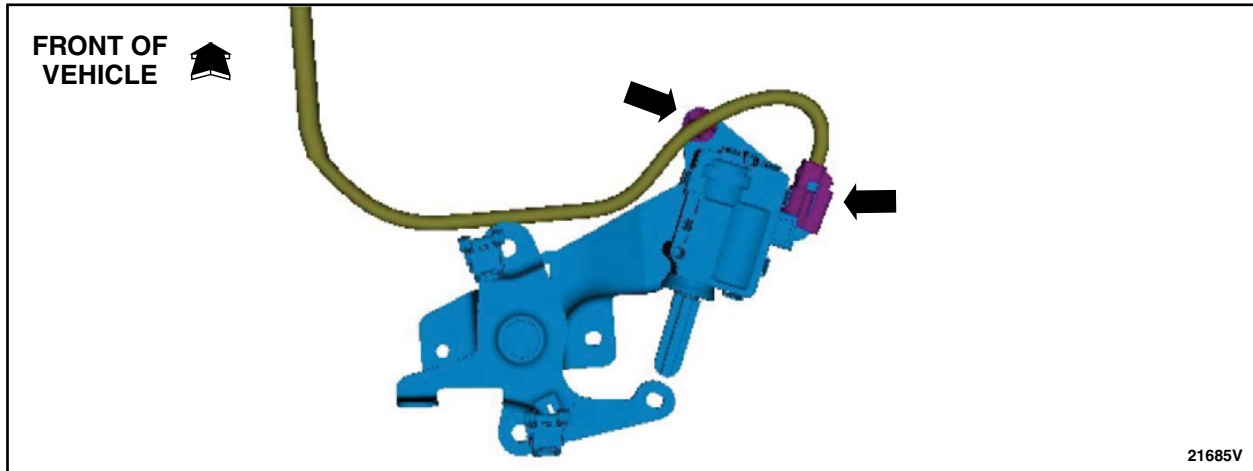

FIGURE 49



69. Using a straightened coat hanger, tape the end of the Tailgate Jumper Harness Wire without a terminal to one end of the coat hanger. Route the wire and coat hanger on the Left Hand (LH) side of the tailgate latch control assembly and through the opening in the center bottom of the tailgate. Continue to pass through the opening in the bed and down through the bottom of the vehicle. See Figure 50.

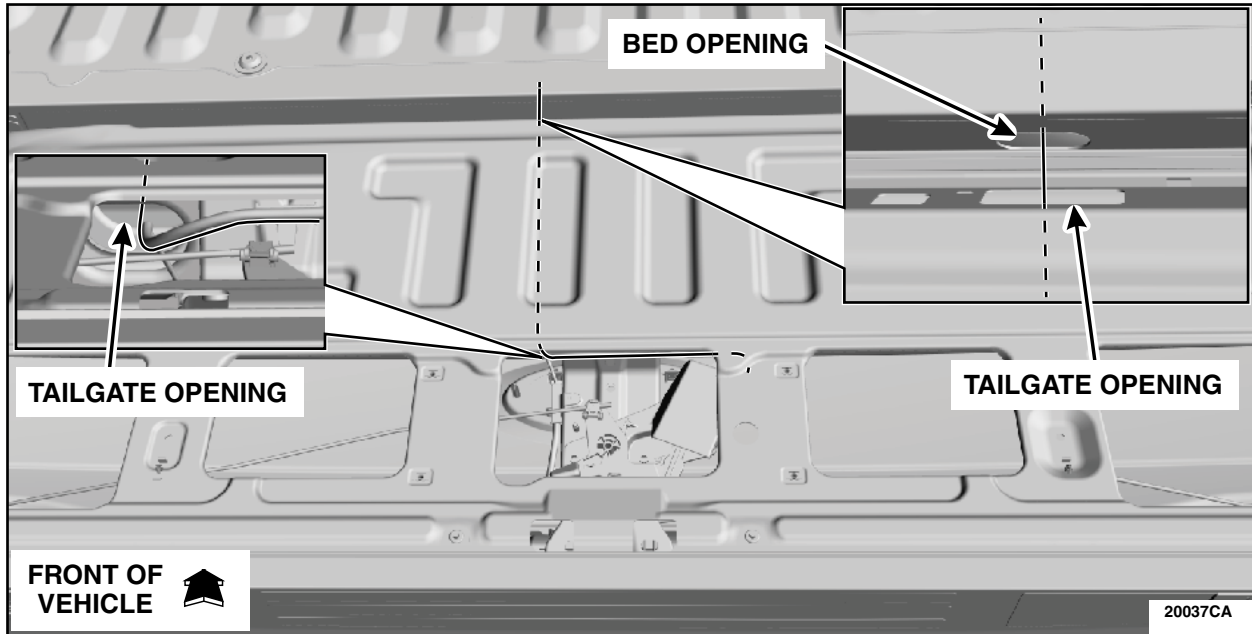

FIGURE 50

70. Secure the Tailgate Jumper Harness using tie straps and trim any excess length of tie strap. See Figure 51.

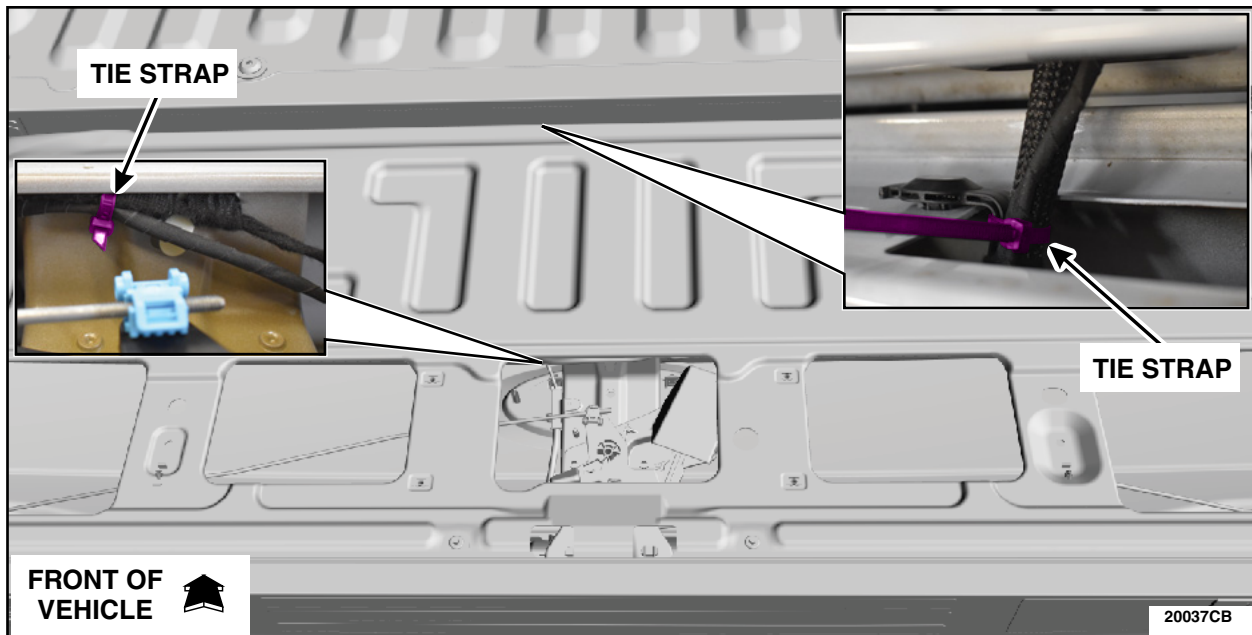

FIGURE 51





71. Position back the tailgate latch control assembly and install the nuts. See Figure 52.

- Torque: 80 lb.in (9 Nm)

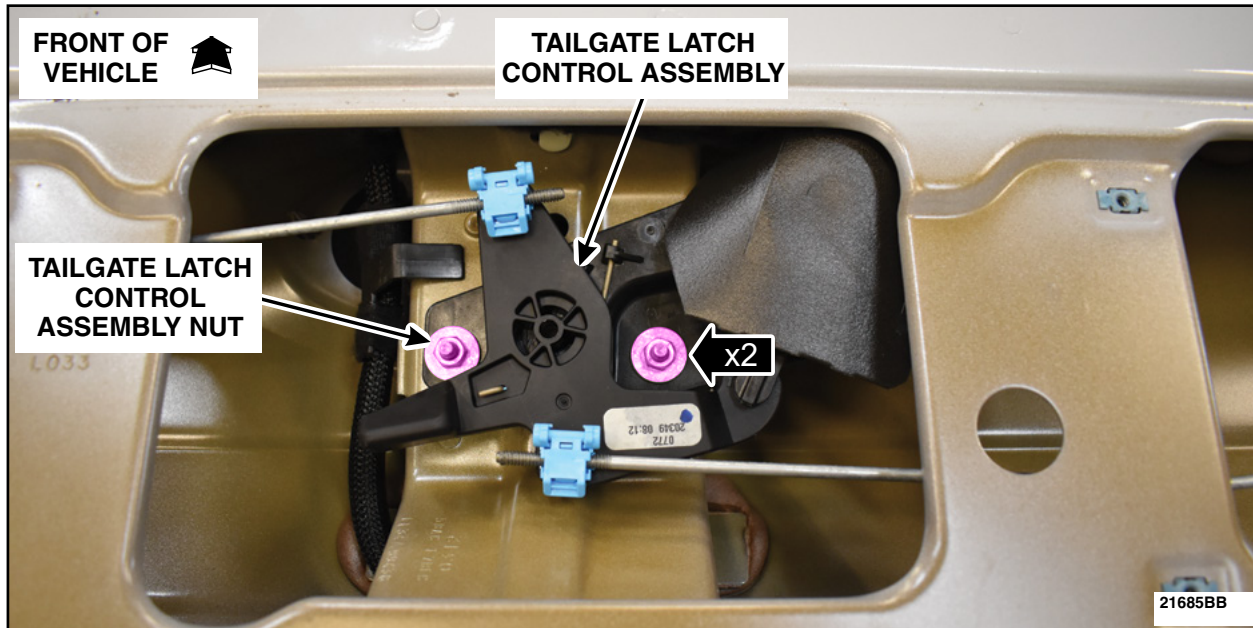

**FIGURE 52**

72. Replace the Tailgate Release Switch. Please follow the WSM procedures in Section 501-14.

- Camera alignment is not required.

73. Using the vehicle spare tire rod, lower the spare tire and secure it out of the way using a ratchet strap or other similar device.

74. Position the vehicle on a hoist. Please follow the WSM procedures in Section 100-02.





75. Inspect underneath the rear of the vehicle, on the bed support, and determine if a Tailgate Jumper Pigtail is present. See Figure 53.

- Is the vehicle equipped with a Tailgate Jumper Pigtail?

YES - Proceed to Step 76 (Page 48).

NO - Proceed to **Tailgate Jumper Pigtail Procedure** on page 32.

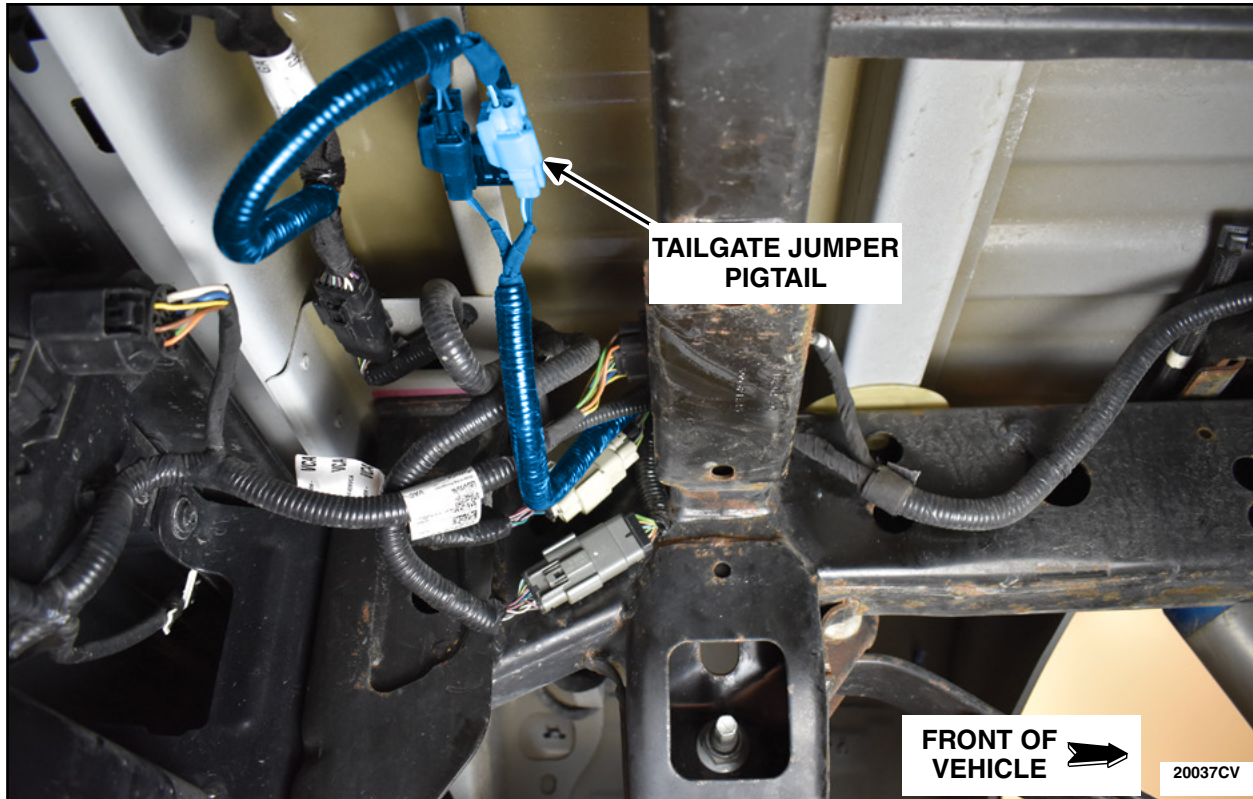

FIGURE 53



Tailgate Jumper Pigtail Procedure

Complete Tailgate Jumper Pigtail Part Kit

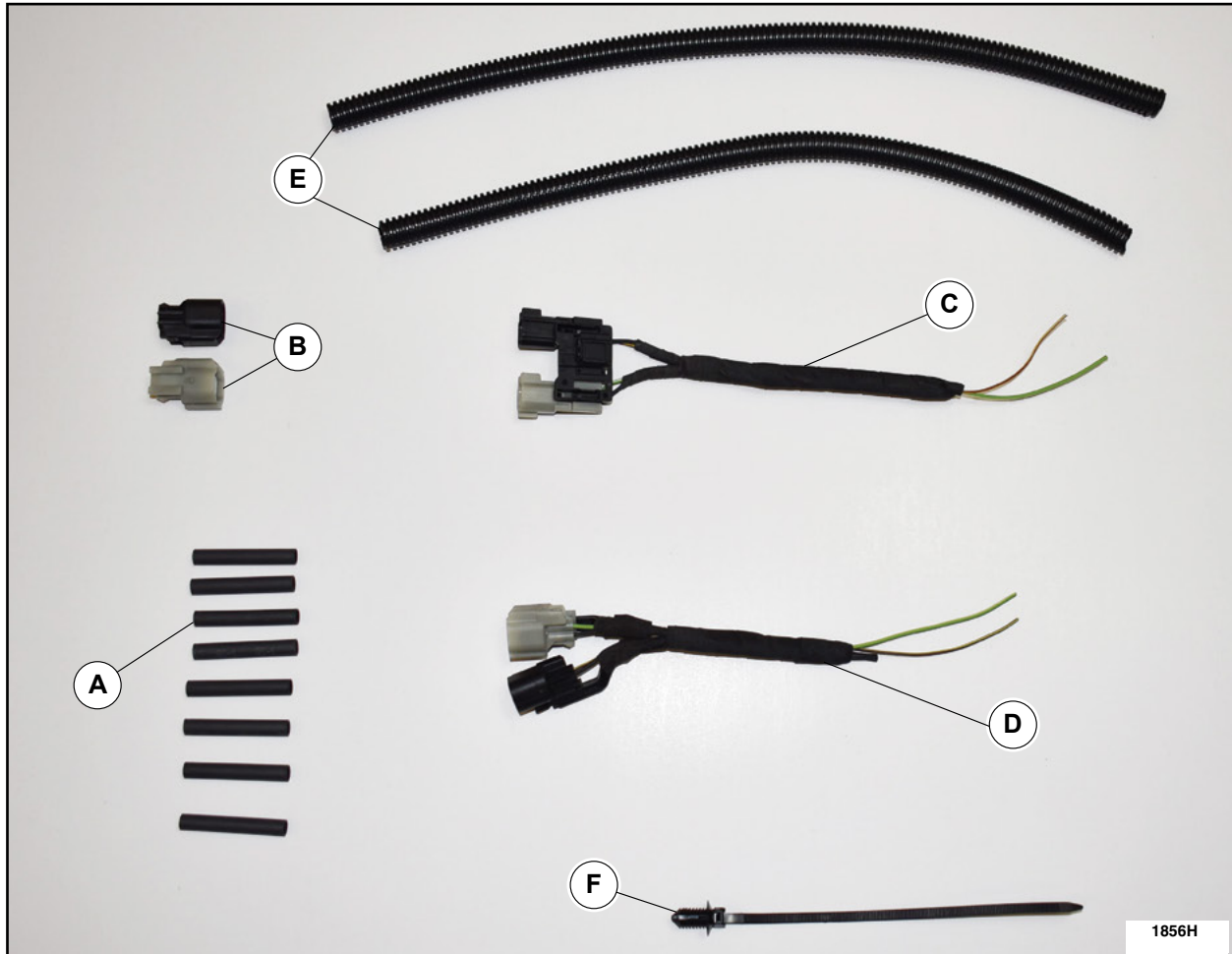

FIGURE 54

ITEM	DESCRIPTION	QUANTITY
A	Dual Wall Heat Shrink Tubing	8
B	Delete Caps	2
C	Male end of <i>New Jumper Pigtail</i>	1
D	Female end of <i>New Jumper Pigtail</i>	1
E	Convolute	2
F	Push Pin Tie Strap	1

**NOTE:** The parts being installed in this procedure are not labeled. Refer to Figure 54 for component identification.



1. Disconnect inline connector C408 and C405 located on the left hand (LH) side of the frame at the rear of the vehicle. See Figure 55.

**NOTE:** If a service pigtail was installed it is possible that the wire colors will not match the figures below.

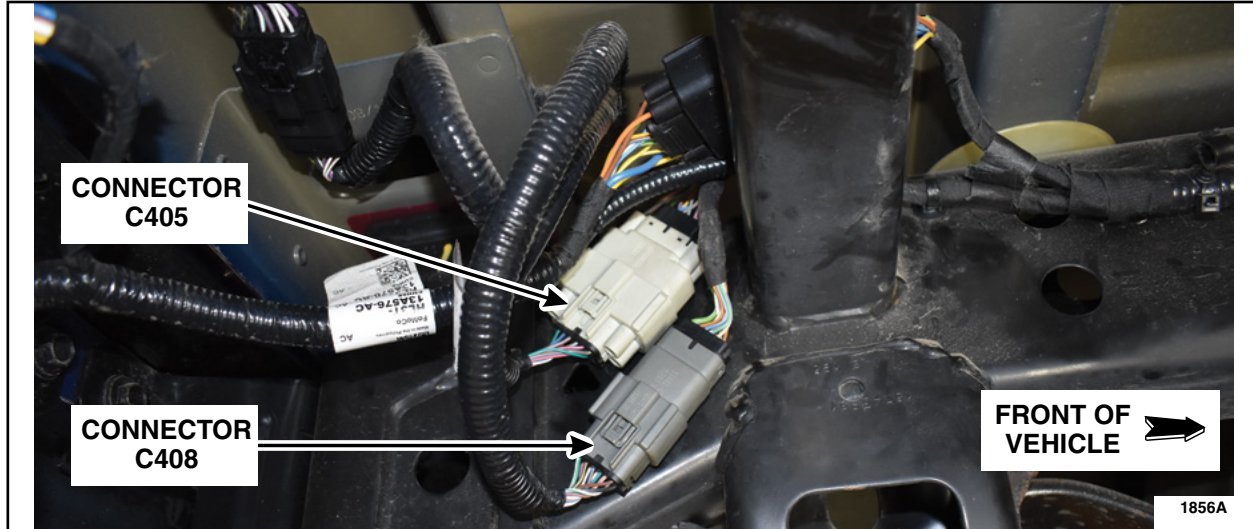

**FIGURE 55**

2. Blow dry both halves of C408 with compressed air.
3. Detach the two connectors and the wire harness push pin retainers. See Figure 56.

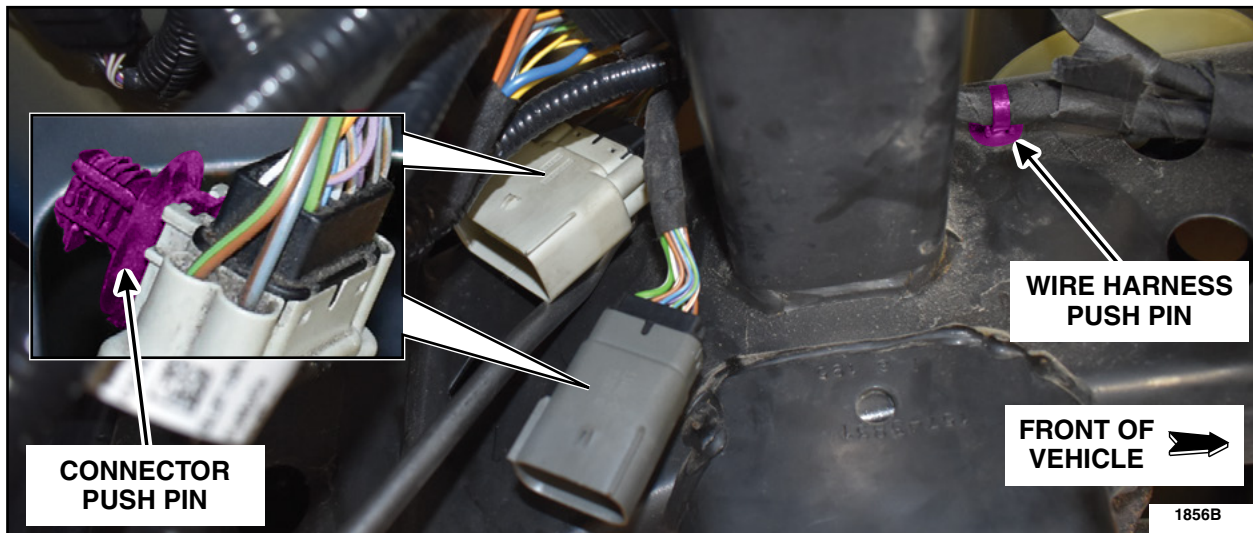

**FIGURE 56**





4. Route the C405 and C408 halves up over the frame and under the attached wire harness to allow for more slack. See Figure 57.



FIGURE 57





**NOTE:** If a service pigtail was installed, it is possible that the wire colors will not match the figures below. The wires in cavities 1 and 2 will remain the affected wires.

5. Measure 140 mm (5.5 in) from the back of the male end of C408. Remove 140 mm (5.5 in) of tape to expose the wires. See Figure 58.

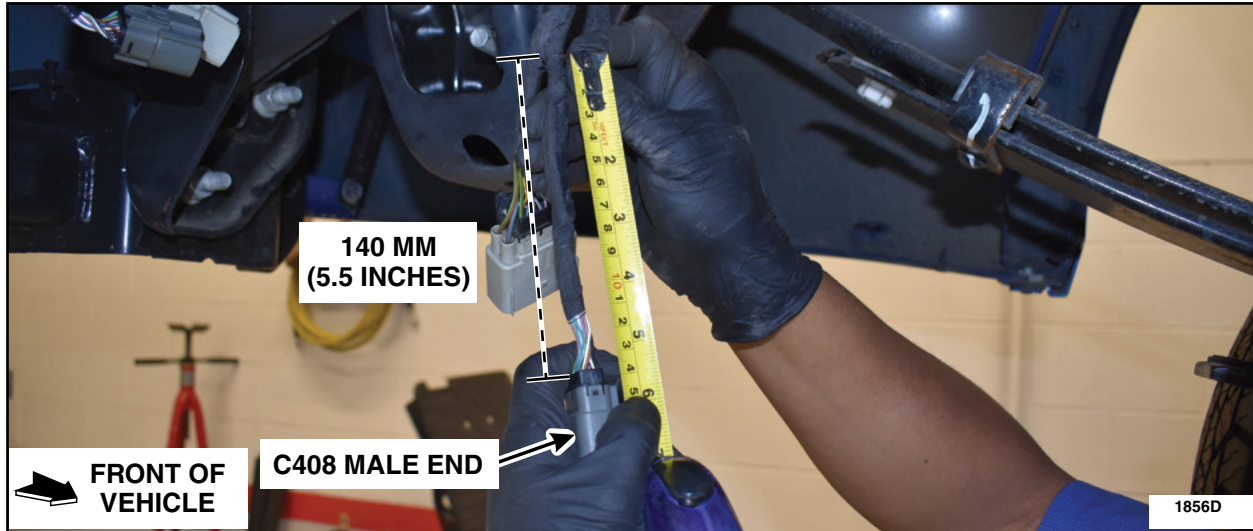

FIGURE 58

6. Measure 50 mm (2 in) from the back side of the male end of C408 and cut the Green-White (GN-WH) wire (cavity 1) at the 50 mm (2 in) measurement. See Figure 59.

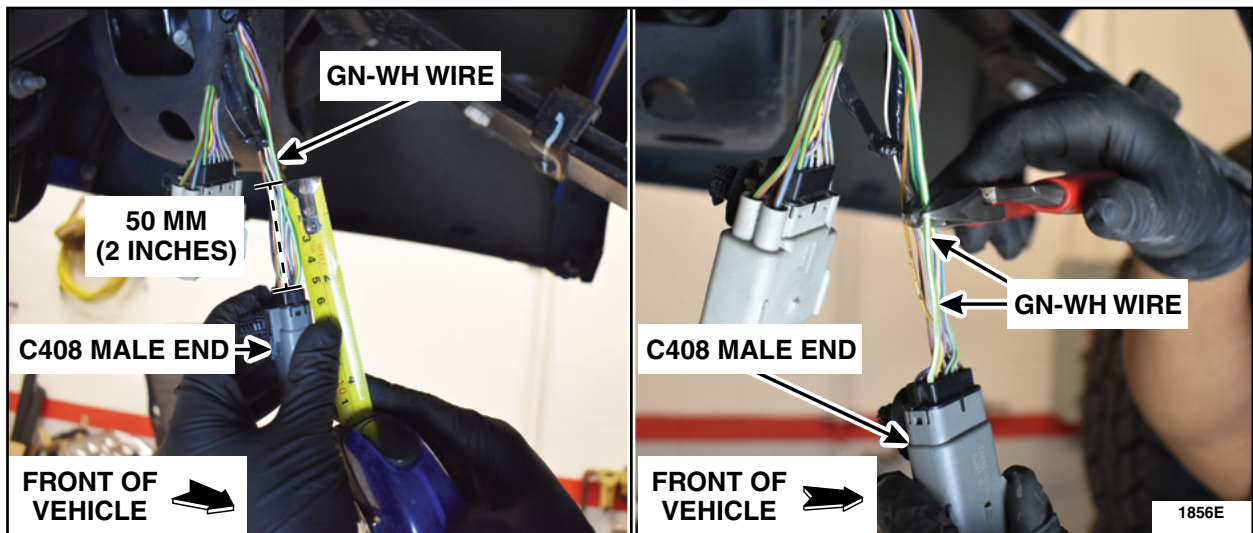

FIGURE 59



7. Measure 50 mm (2 in) from the back side of the male end of C408 and cut the Brown-Yellow (BN-YE) wire (cavity 2) at the 50 mm (2 in) measurement. See Figure 60.

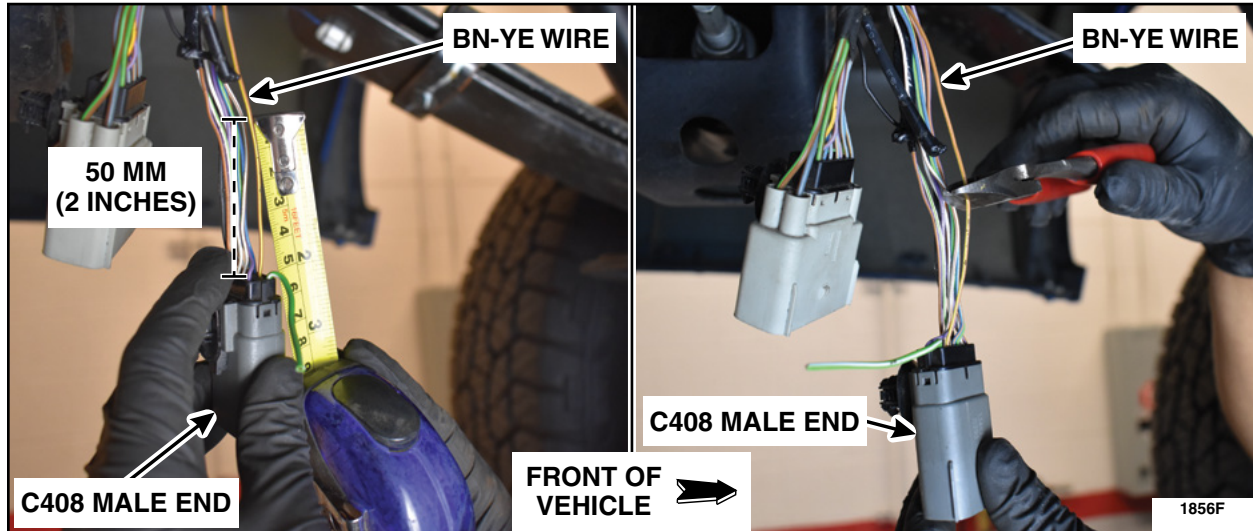

FIGURE 60

8. Install a piece of dual wall heat shrink tube on the GN-WH and BN-YE wires making sure the end of the wire is located in the middle of the tube. Evenly heat up the heat shrink tube until the heat shrink tube sealant bubbles out of both ends. See Figure 61.

**NOTE:** Make sure the heat shrink sealant is bubbled out of both ends or the circuit is not sealed.

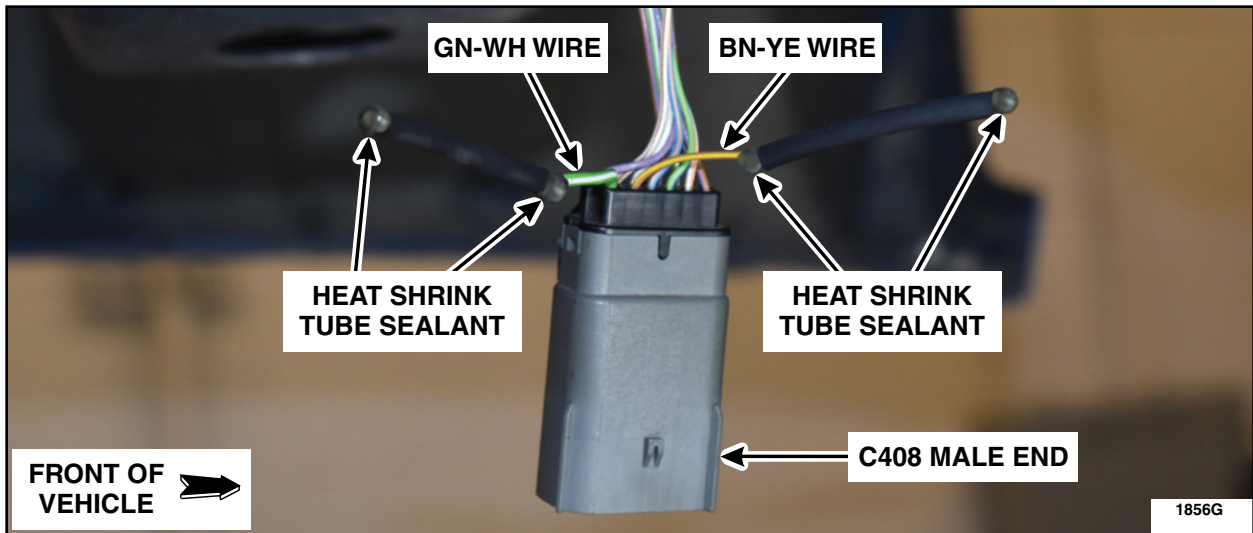

FIGURE 61



9. Strip 9.5 mm (3/8 in) of the GN-WH and BN-YE wire insulation on the male connector harness side.  
See Figure 62.

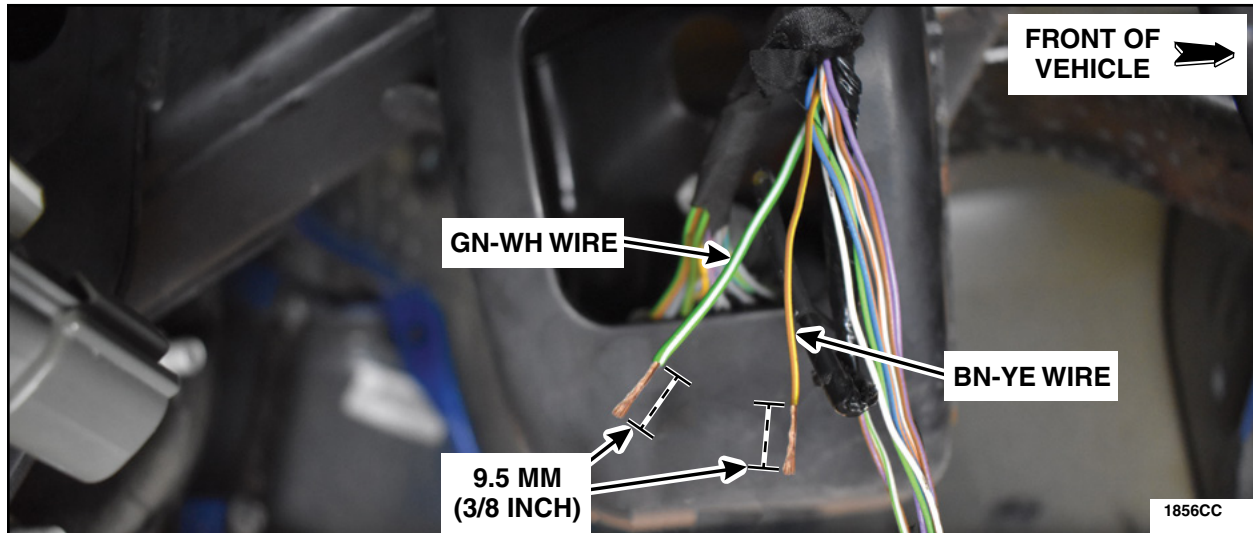

FIGURE 62

10. Strip 9.5 mm (3/8 in) of the wire insulation on the *new* jumper harness male connector end.  
See Figure 63.

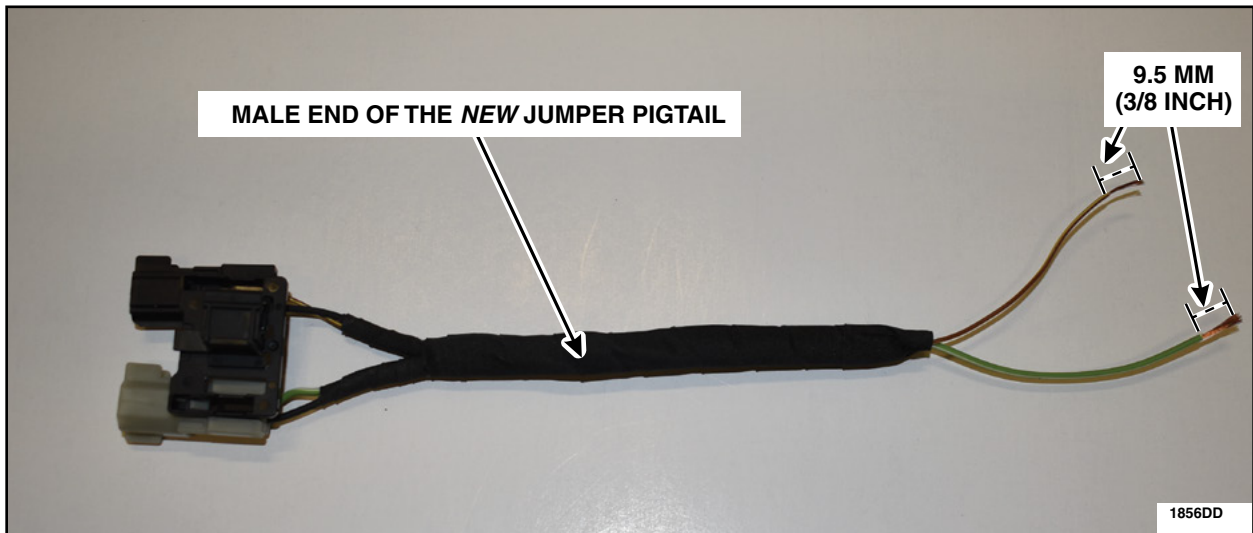

FIGURE 63





**NOTE:** Do not leave any stray strands of wire poking outwards as this may puncture the heat shrink tube when heated.

11. Place a heat shrink tube onto each GN-WH and BN-YE wires. Install the male end of the *new* jumper pigtail to the corresponding wire colors of the male end of the vehicle harness by twisting the exposed wires together. See Figure 64.

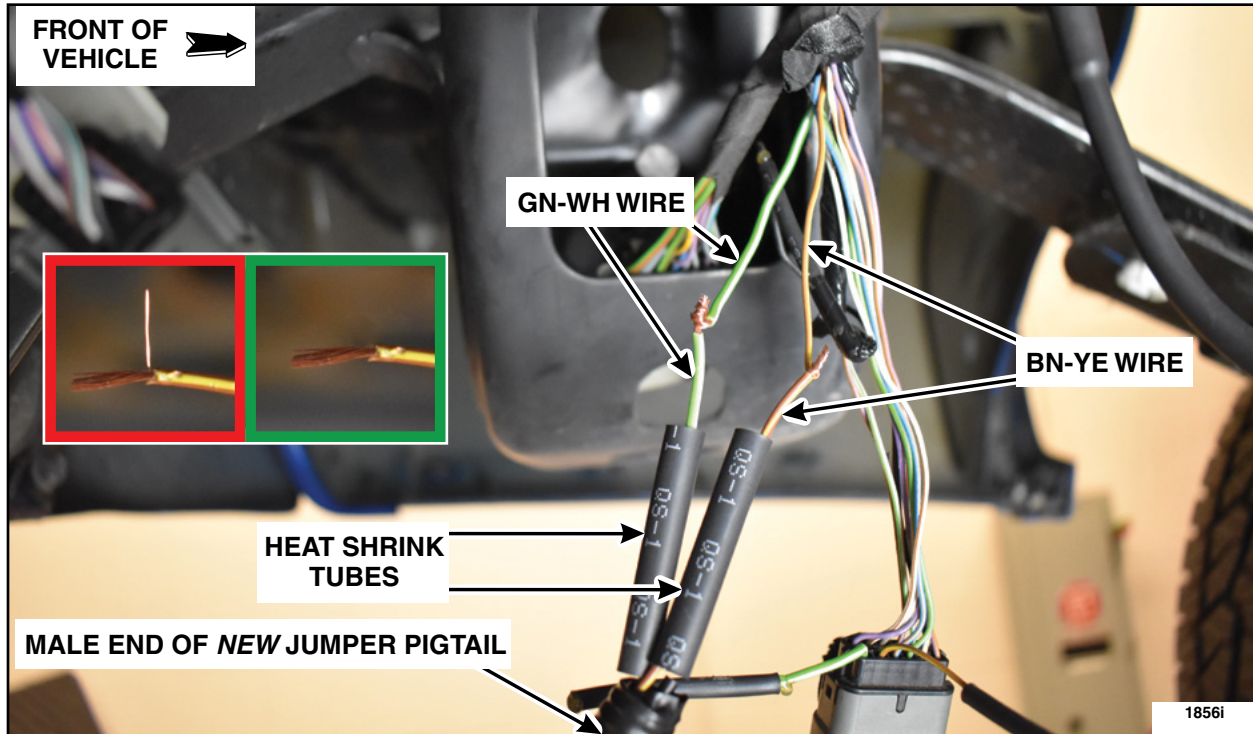

**FIGURE 64**

12. Solder the twisted wires of the male connector. See Figure 65.

**NOTE:** Keep the heat shrink tubes away from the soldering iron.

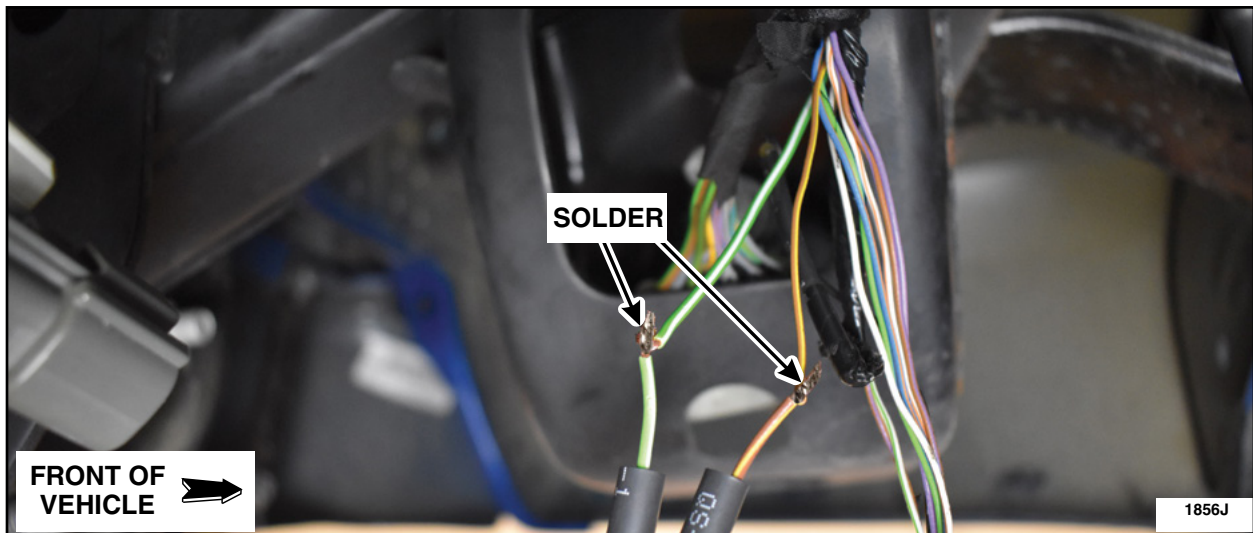

**FIGURE 65**





12. Position the dual wall heat shrink tubes over the solder joints making sure the joints are located in the middle of the tubes. Evenly heat up the heat shrink tubes until the heat shrink tube sealant bubbles out of both ends. See Figure 66.

**NOTE:** Make sure the heat shrink sealant is bubbled out of both ends or the circuit is not sealed.

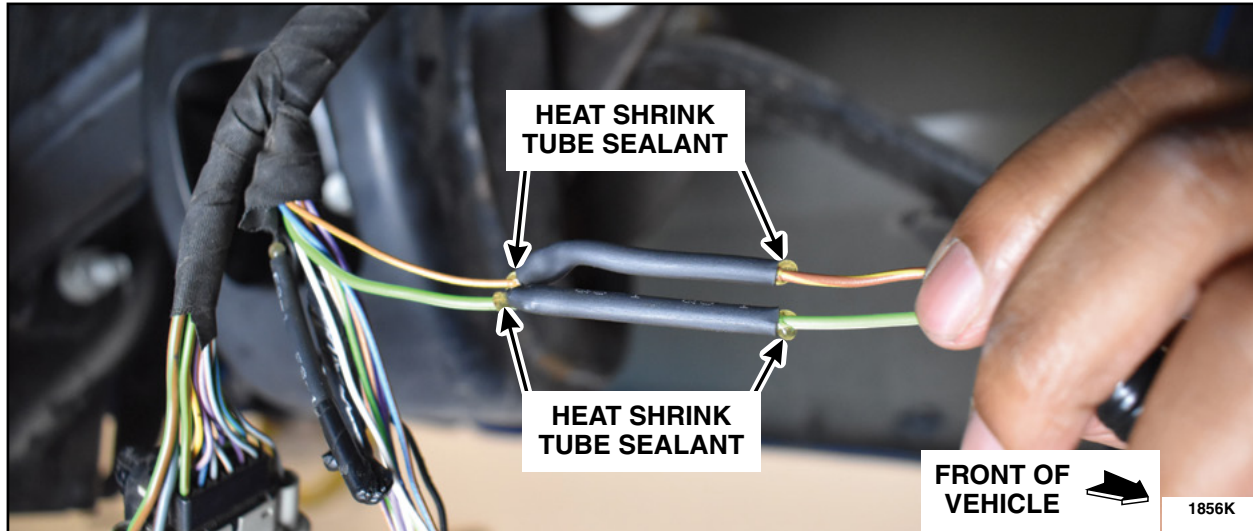

**FIGURE 66**

13. Disconnect the tailgate inline connector (12 pin or 16 pin). See Figure 67.

**NOTE:** C406 12 pin inline connector for 2017 model year shown, all other 12 pin and 16 pin inline connectors similar.

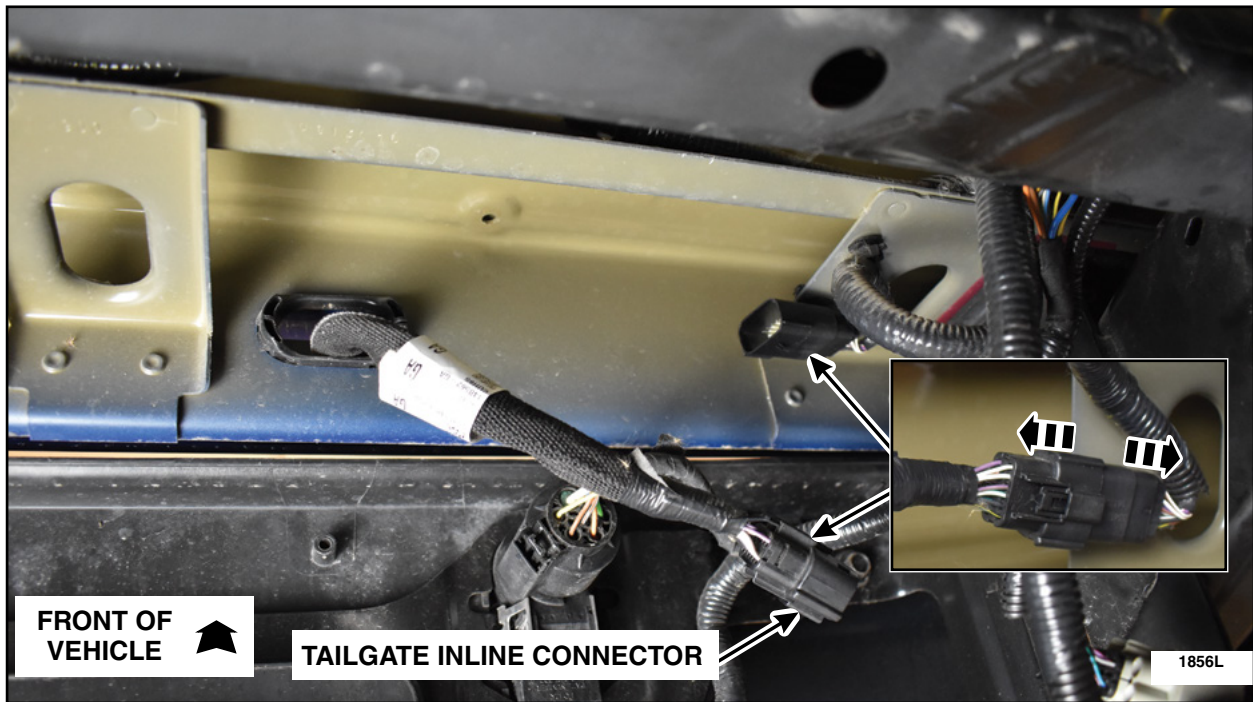

**FIGURE 67**



**NOTE:** If a service pigtail was installed, it is possible that the wire colors will not match the figures below. The wire cavities below will remain the affected wires.

For 16 pin connector - GN-WH is cavity 8, BN-YE is cavity 15.  
For 12 pin connector - GN-WH is cavity 12, BN-YE is cavity 10.

14. Remove the tape and slide back the mesh cover to expose 140 mm (5.5 in) of the wires on the female side of the tailgate inline connector. See Figure 68.

**NOTE:** C406 12 pin inline connector for 2017 model year shown, all other 12 pin and 16 pin inline connectors similar.

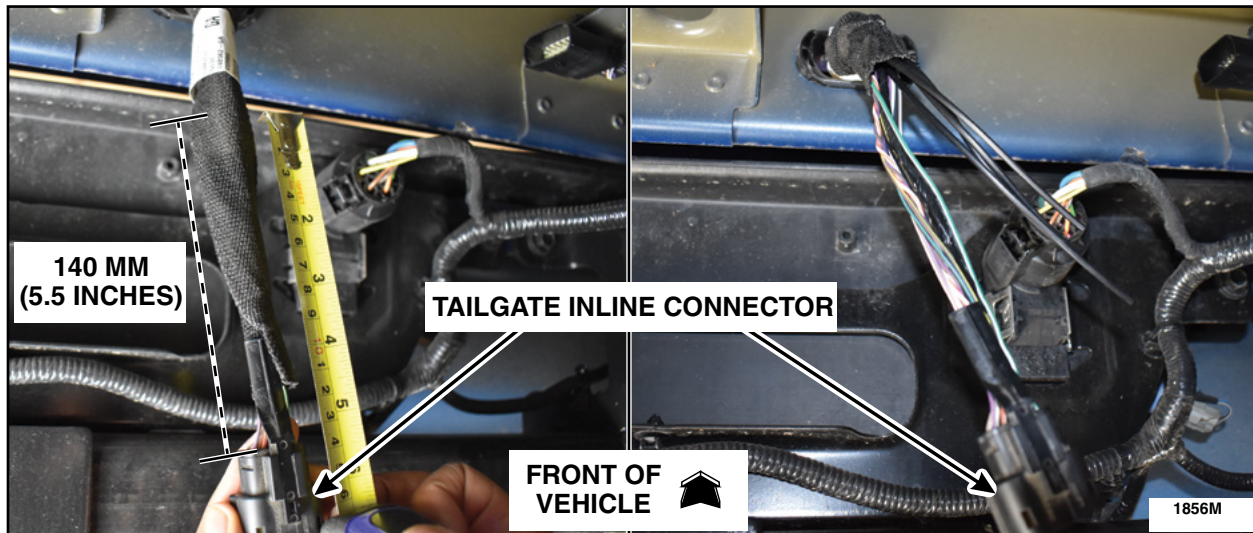

**FIGURE 68**

15. Measure 50 mm (2 in) from the back side of the tailgate inline connector female end and cut the GN-WH wire (16 pin connector: cavity 8 OR 12 pin connector: cavity 12). See Figure 69.

**NOTE:** C406 12 pin inline connector for 2017 model year shown, all other 12 pin and 16 pin inline connectors similar.

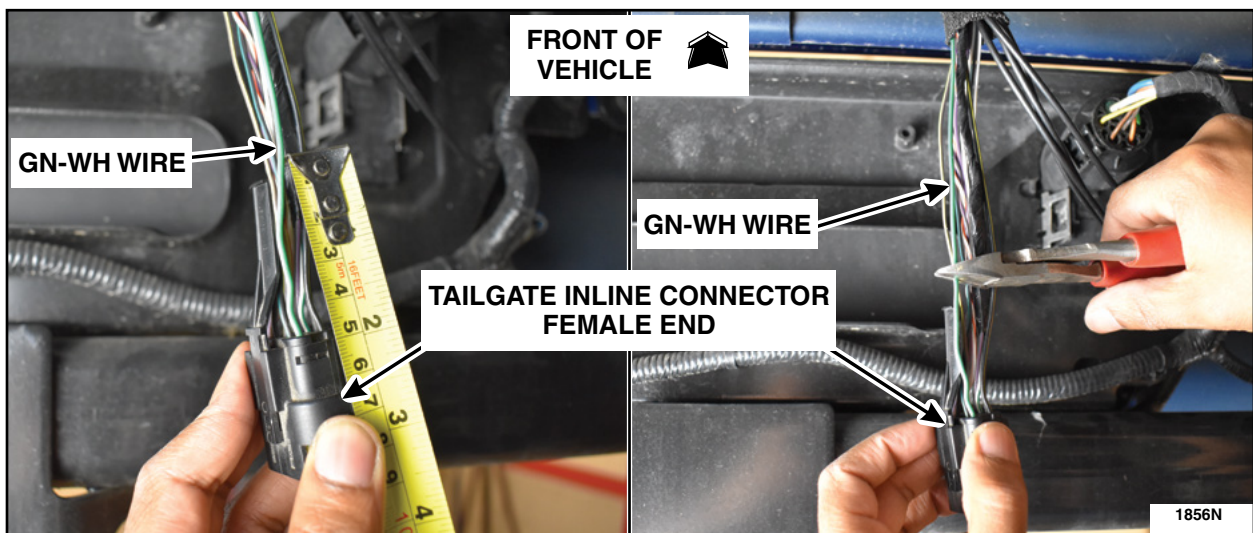

**FIGURE 69**





16. Measure 50 mm (2 in) from the back side of the tailgate inline connector female end and cut the BN-YE wire (16 pin connector: cavity 8 OR 12 pin connector: cavity 12). See Figure 70.

**NOTE:** C406 12 pin inline connector for 2017 model year shown, all other 12 pin and 16 pin inline connectors similar.

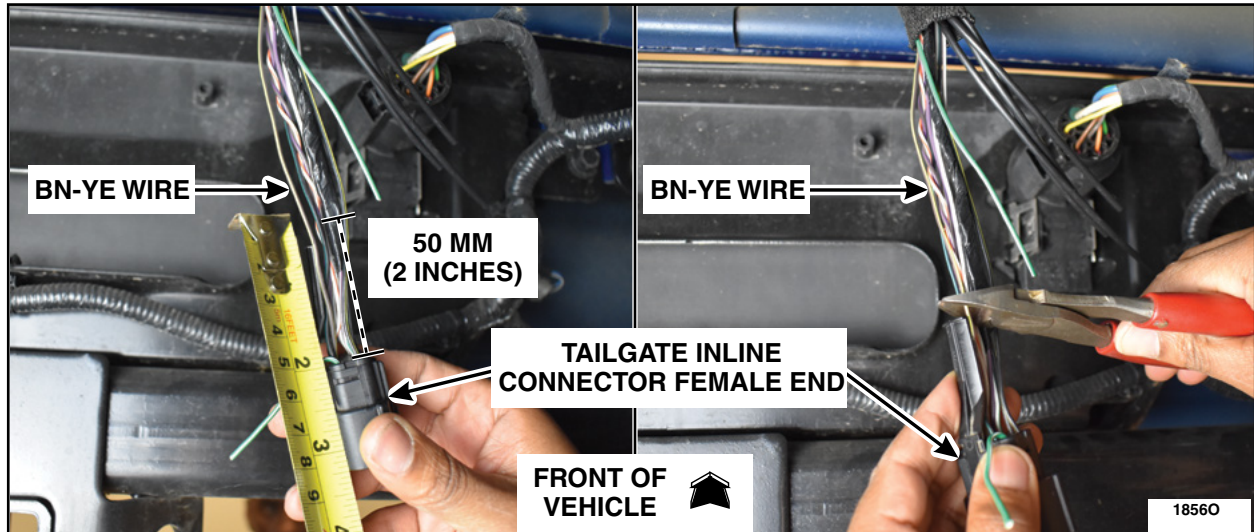

FIGURE 70

17. Install a piece of dual wall heat shrink tube on the GN-WH and BN-YE wires making sure the end of the wire is located in the middle of the tube. Evenly heat up the heat shrink tube until the heat shrink tube sealant bubbles out of both ends. See Figure 71.

**NOTE:** Make sure the heat shrink sealant is bubbled out of both ends or the circuit is not sealed.

**NOTE:** C406 12 pin inline connector for 2017 model year shown, all other 12 pin and 16 pin inline connectors similar.

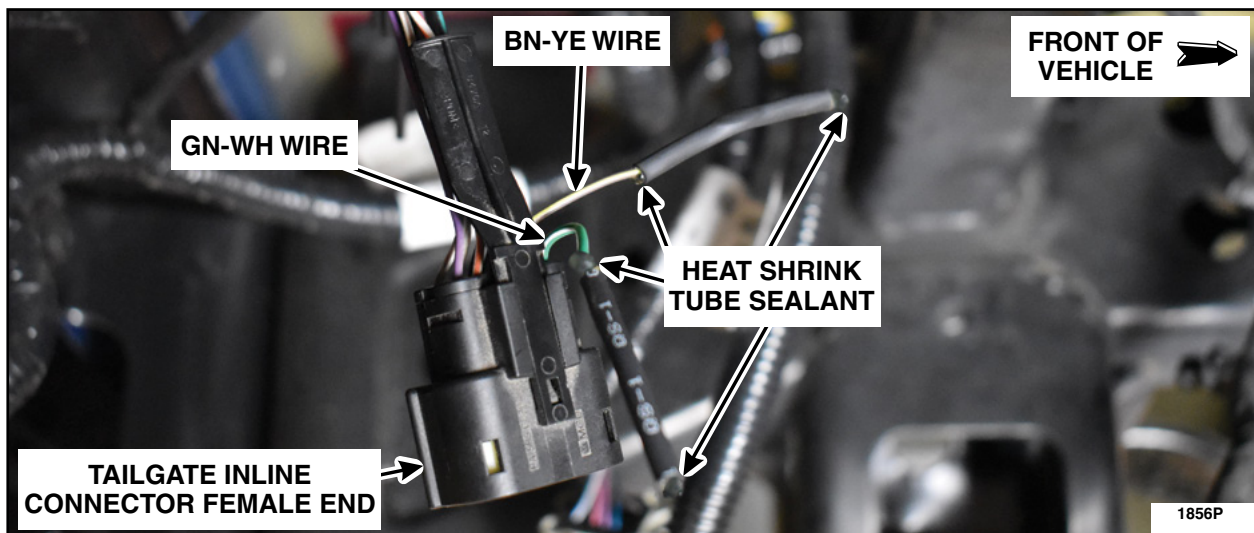

FIGURE 71



18. Strip 9.5 mm (3/8 in) of the GN-WH and BN-YE wire insulation on the female connector harness side. See Figure 72.

**NOTE:** C406 12 pin inline connector for 2017 model year shown, all other 12 pin and 16 pin inline connectors similar.

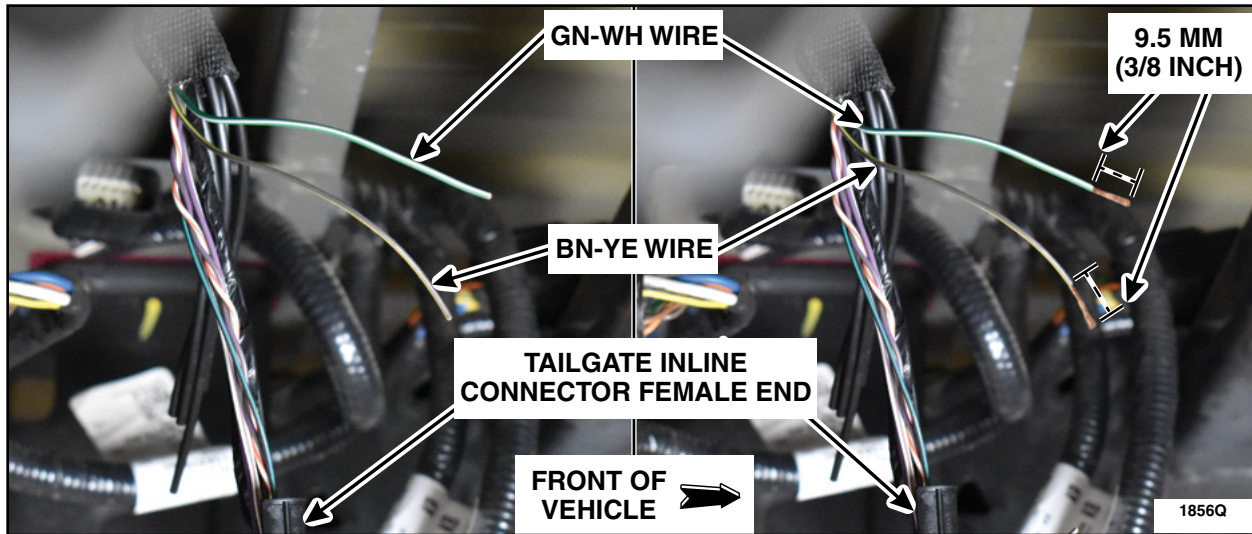

FIGURE 72

19. Strip 9.5 mm (3/8 in) of the wire insulation on the *new* jumper pigtail female connector end. See Figure 73.

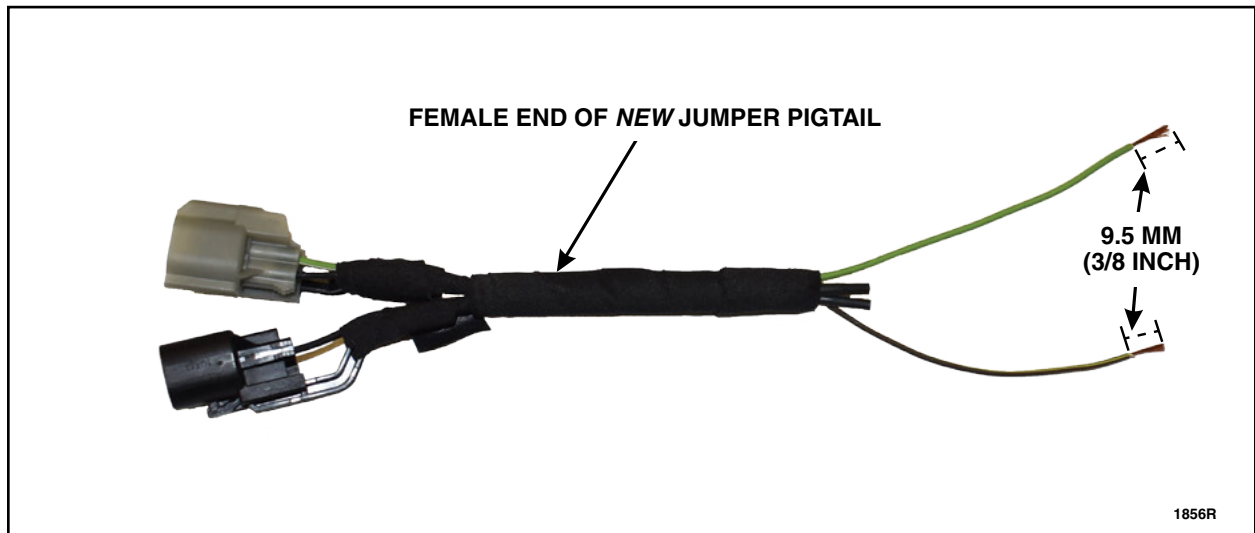

FIGURE 73





**NOTE:** Do not leave any stray strands of wire poking outwards as this may puncture the heat shrink tube when heated. See the red and green highlighted callouts below.

20. Place a piece of dual wall heat shrink tube onto each GN-WH and BN-YE wires. Install the female end of the *new* jumper pigtail to the corresponding wire colors of the female end of the vehicle harness by twisting the exposed wires together. See Figure 74.

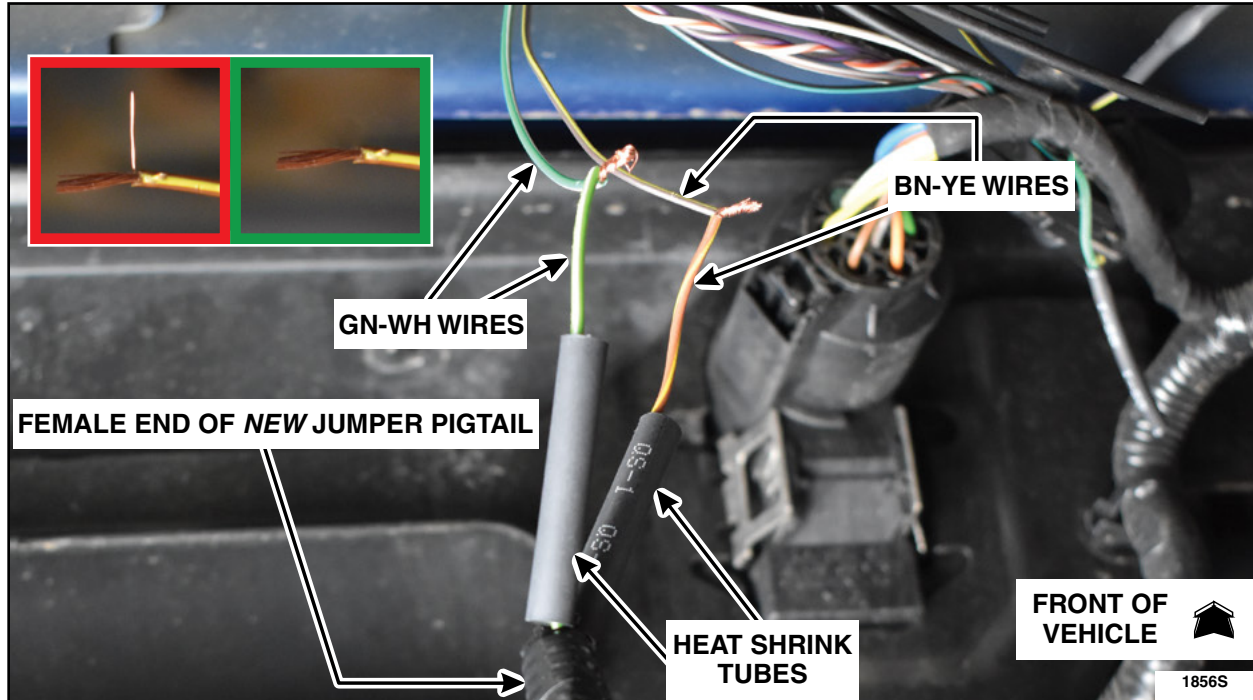

**FIGURE 74**

21. Solder the twisted wires of the female connector. See Figure 75.

**NOTE:** Keep the heat shrink tubes away from the soldering iron.

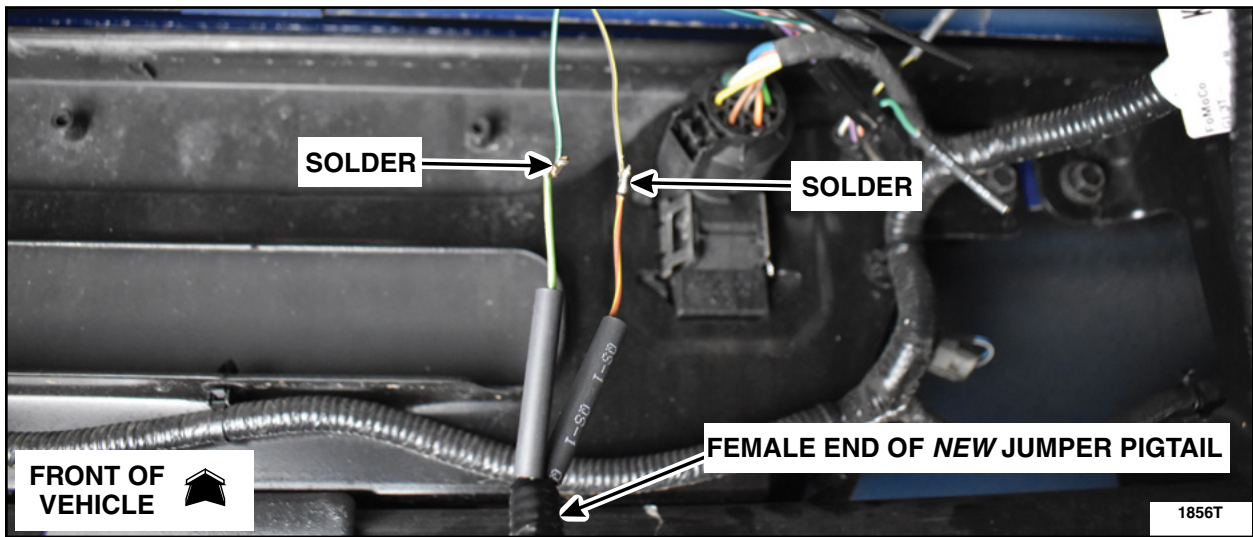

**FIGURE 75**



22. Position the dual wall heat shrink tubes over the solder joints making sure the joints are located in the middle of the tubes. Evenly heat up the heat shrink tubes until the heat shrink tube sealant bubbles out of both ends. See Figure 76.

**NOTE:** Make sure the heat shrink sealant is bubbled out of both ends or the circuit is not sealed.

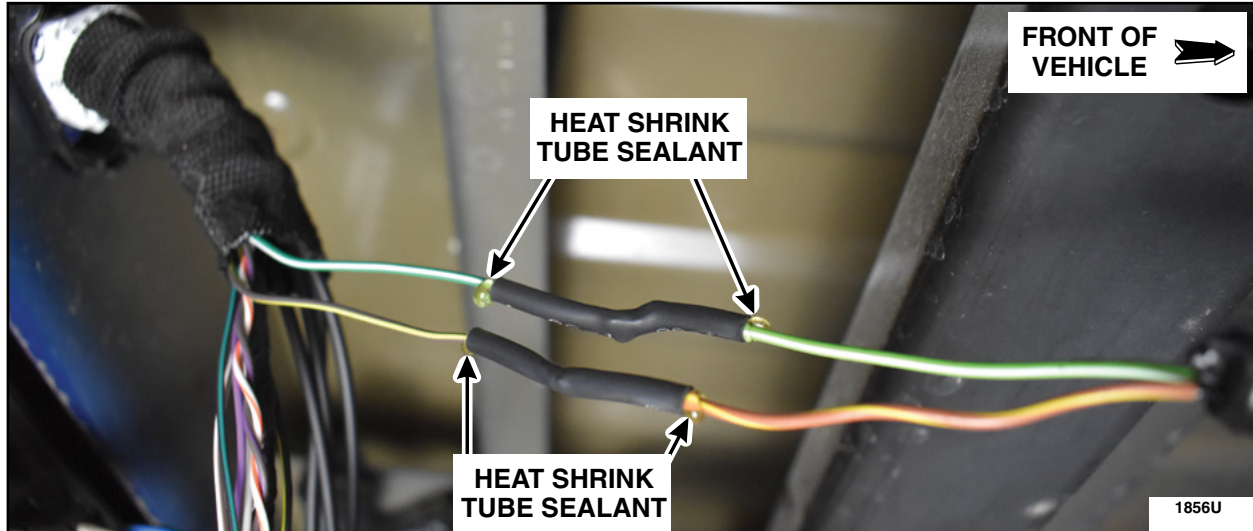

FIGURE 76

23. Position back the mesh cover. Cut to fit the *new* convolute and properly cover any exposed wiring then secure using electrical tape. See Figure 77.

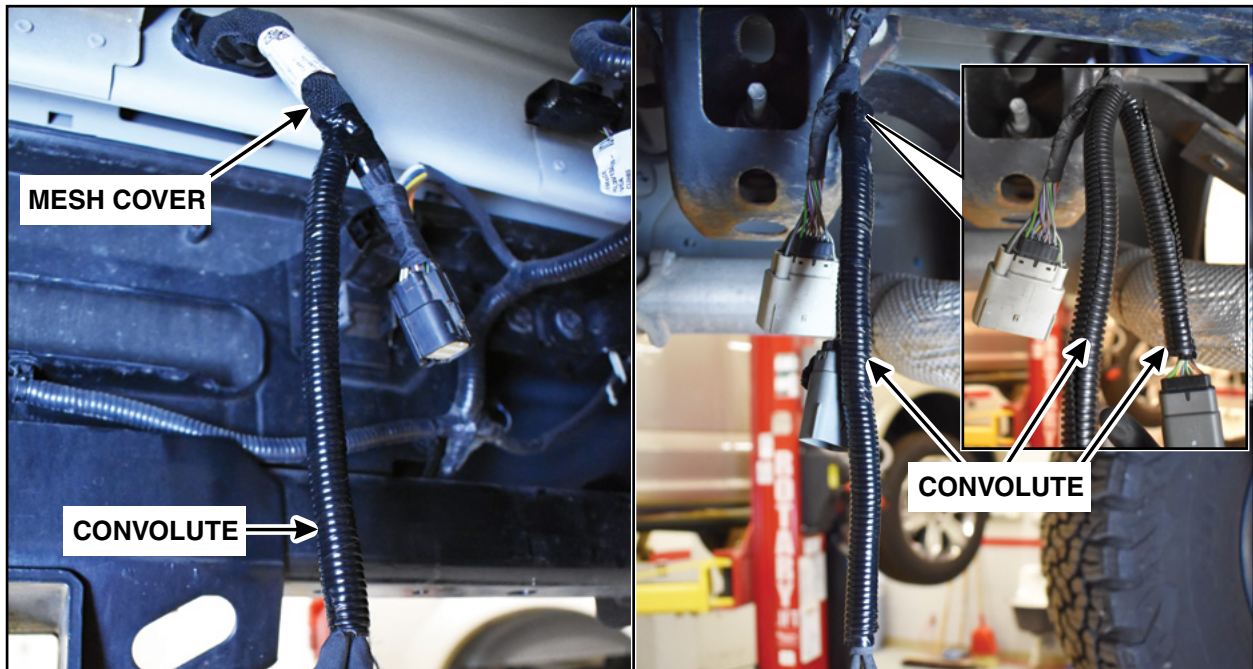

FIGURE 77





24. Route the male end of the *new* jumper pigtail, C405 and C408 halves under the attached wire harness and over the frame. See Figure 78.

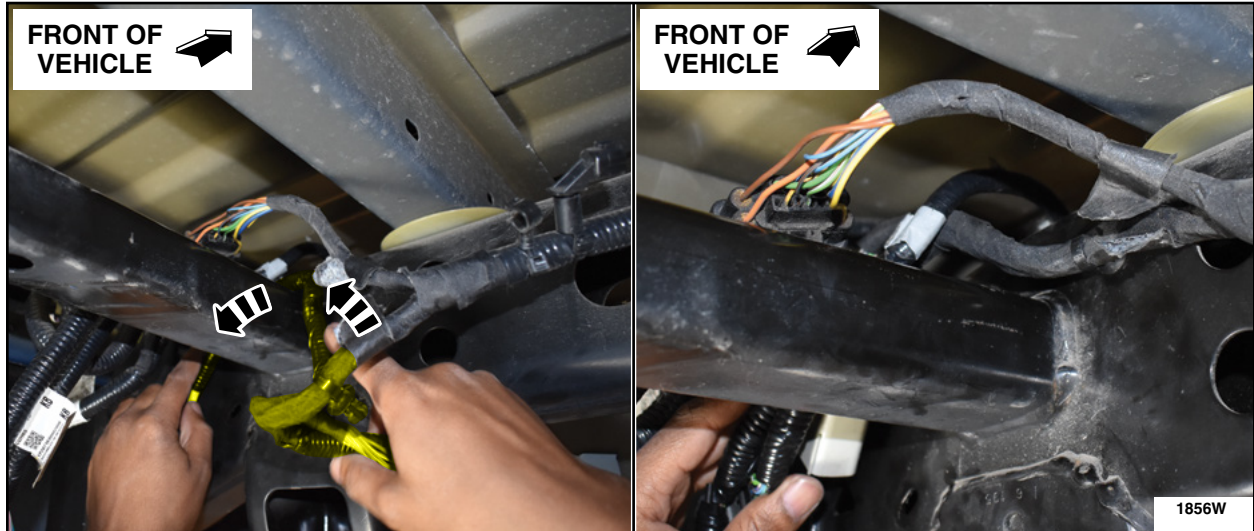

FIGURE 78

25. Attach the two connectors push pin and the wire harness push pin retainers. See Figure 79.

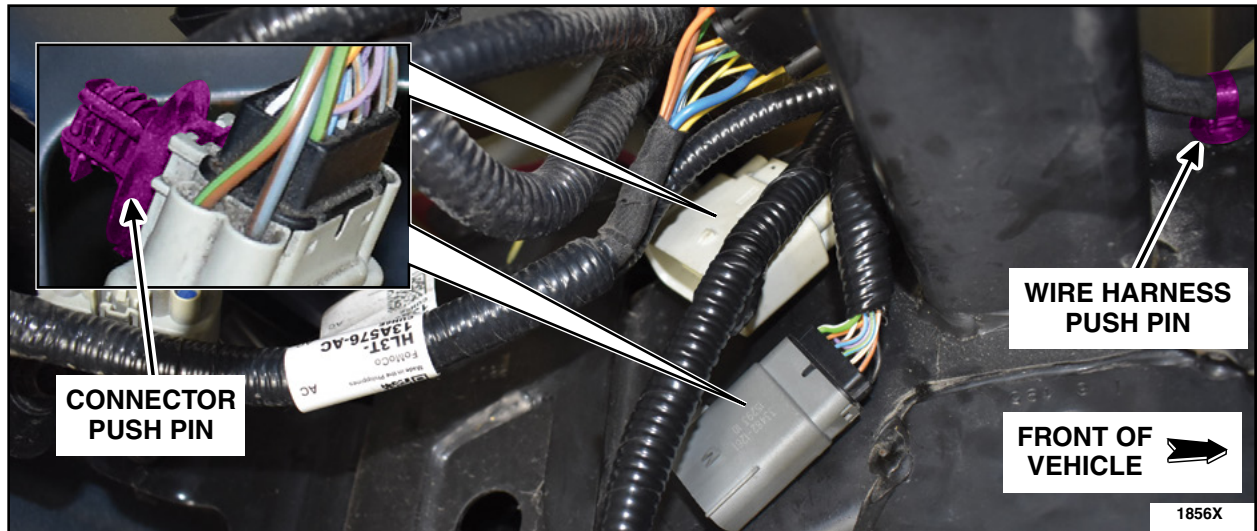

FIGURE 79



26. Apply some Motorcraft® electrical grease (XG-12) to the male side of C408. Inject the grease straight from the tube filling the connector cavity halfway being careful not to bend or damage any terminals.
27. Connect inline connector C405 and C408. See Figure 80.

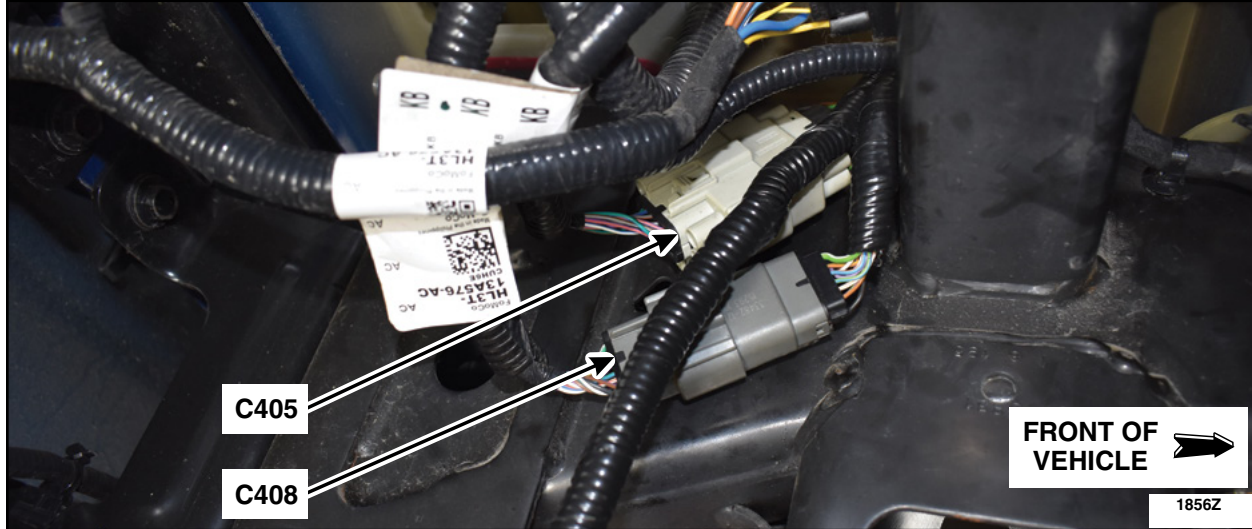

FIGURE 80

28. Apply some Motorcraft® electrical grease (XG-12) to the male side of tailgate inline connector. Inject the grease straight from the tube filling the connector cavity halfway being careful not to bend or damage any terminals.
29. Connect the tailgate inline connector. See Figure 81.

**NOTE:** C406 12 pin inline connector for 2017 model year shown, all other 12 pin and 16 pin inline connectors similar.

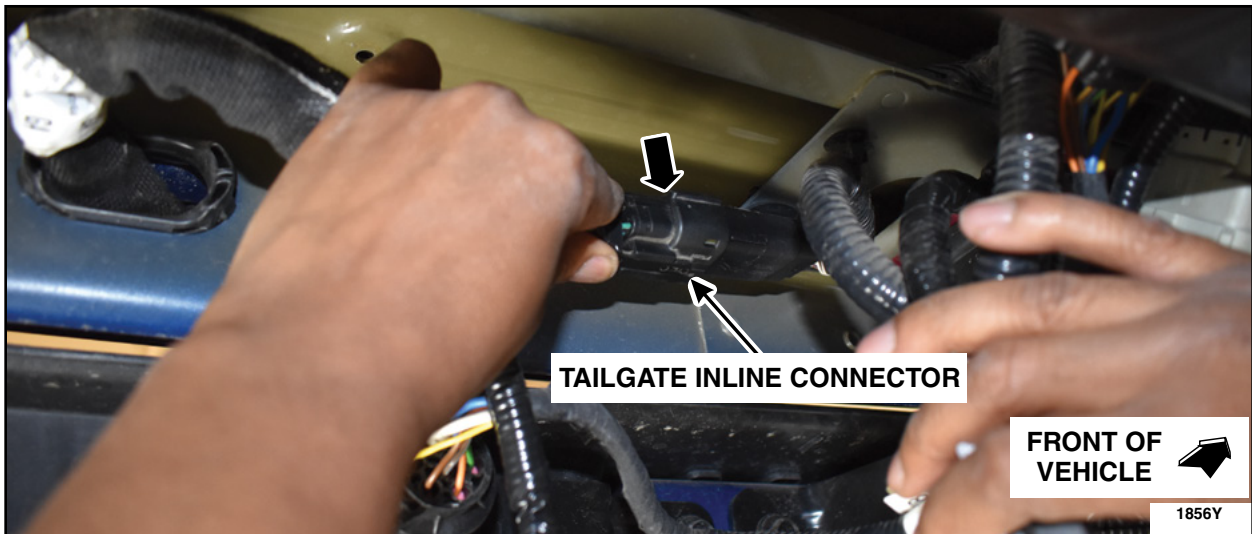
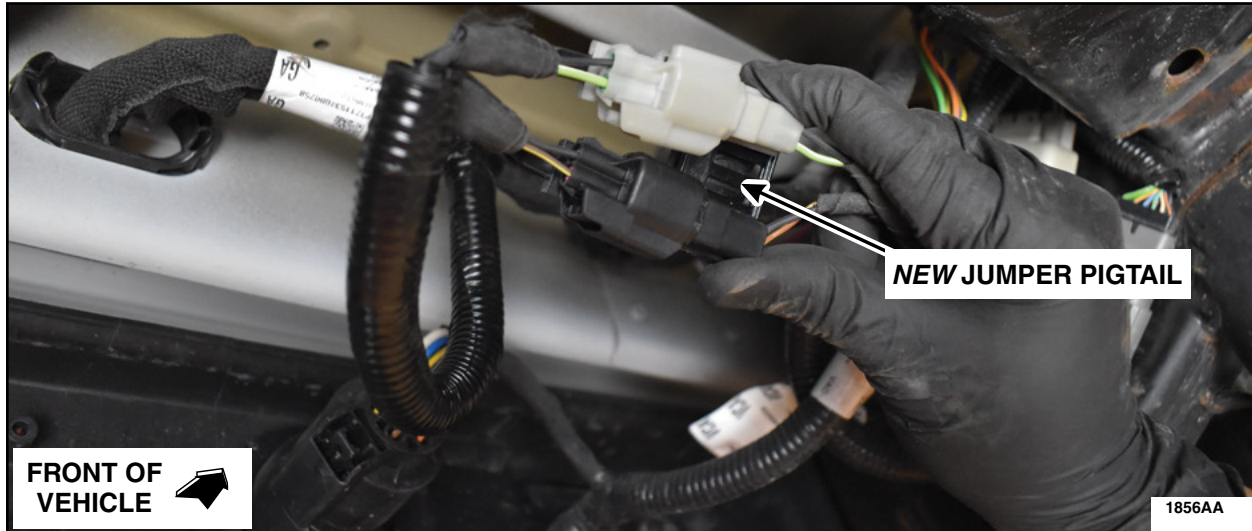

FIGURE 81





30. Connect the *new* jumper pigtail. See Figure 82.



**FIGURE 82**

31. Attach the *new* jumper pigtail to the bed support. See Figure 83.



**FIGURE 83**

**NOTE:** Place the new delete caps included with the tailgate jumper harness part kit into the glove box. If the original delete cap/kit sealable bag is present in the glove box, place the new delete caps inside of it.

32. The Tailgate Jumper Pigtail Procedure is complete. Proceed to Step 76 on Page 48.



76. Disconnect the black and grey connectors of the Tailgate Jumper Pigtail. See Figure 84.



FIGURE 84

77. Remove any tape and/or convolute from the gray connector female end to expose the pin 2 dummy wire. Cut the pin 2 dummy wire just in front of the heat shrink tubing and discard the heat shrink end. Install a *new* piece of heat shrink tubing, twist the Tailgate Jumper Harness and the gray connector female end pin 2 dummy wire together. See Figure 85.

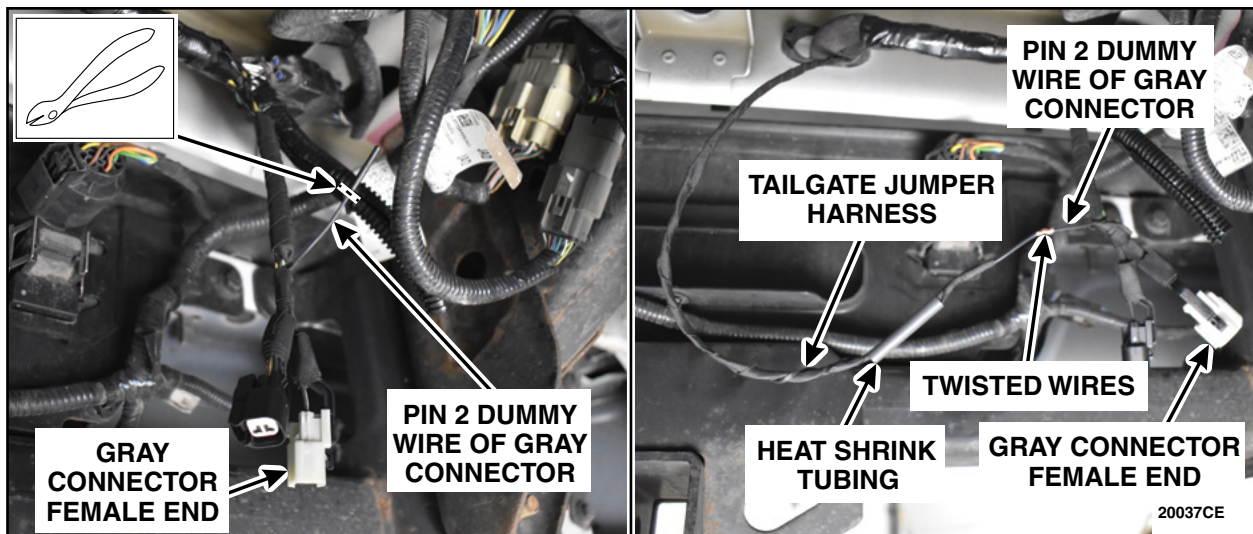

FIGURE 85



78. Solder the twisted wires and apply and seal the heat shrink tubing. See Figure 86. Reapply the convolute and/or black electrical tape.

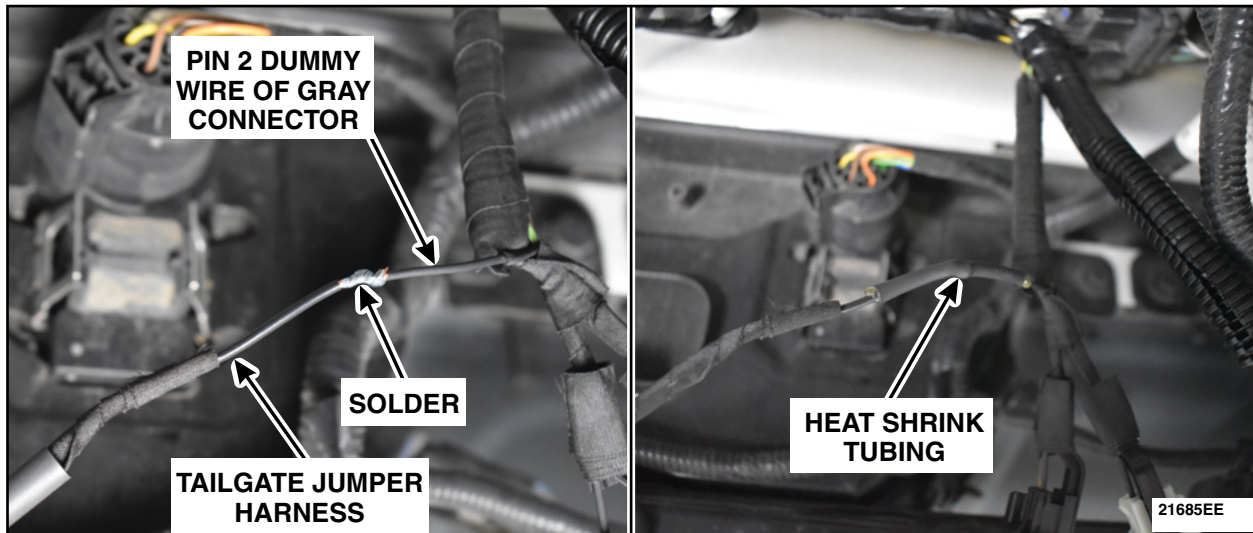

FIGURE 86

79. Remove any tape and/or convolute from the gray connector male end to expose the pin 2 dummy wire. Cut the pin 2 dummy wire just in front of the heat shrink tubing and discard the heat shrink end. Install a *new* piece of heat shrink tubing, twist the end of the Body Length Jumper Harness without a terminal and the connector male end pin 2 dummy wire together. Solder the twisted wires then apply and seal the heat shrink tubing. Reapply the convolute and/or black electrical tape. See Figure 87.

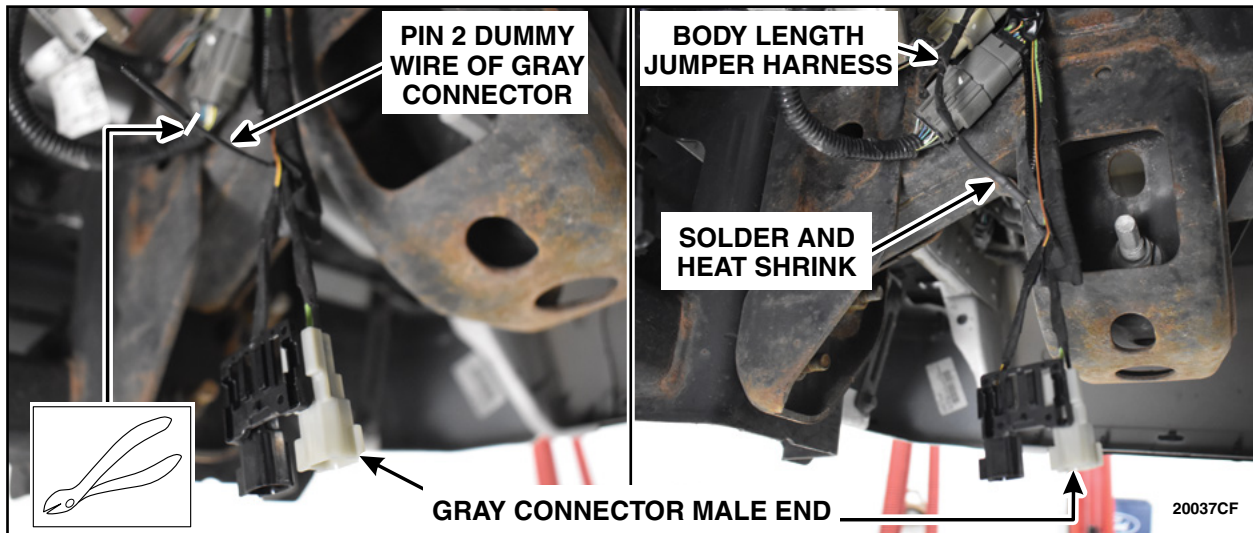

FIGURE 87





80. Reconnect the gray and black connectors and attach them back onto bed support. See Figure 88.

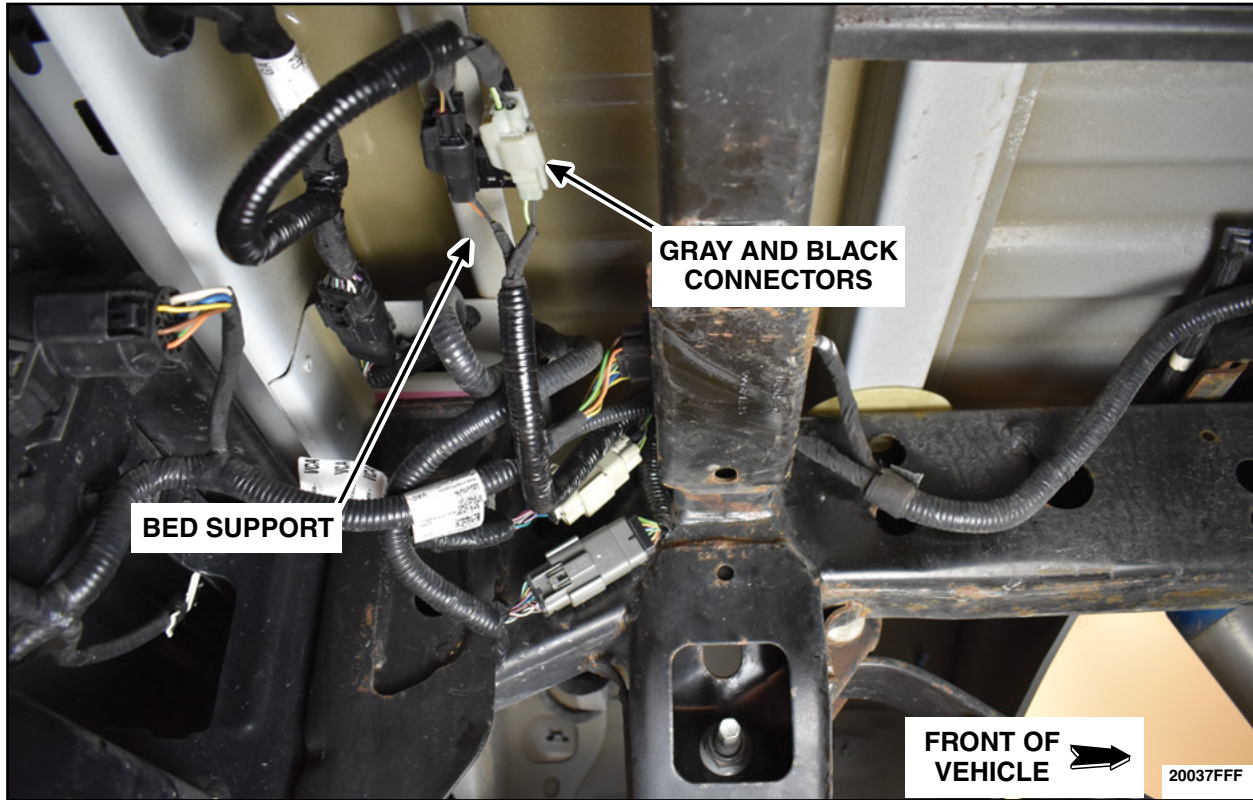

FIGURE 88

81. Route the Body Length Jumper Harness along the LH frame rail towards the front of the vehicle keeping the harness as close to the bed as possible. Secure using tie straps approximately every 12 in (305 mm). See Figure 89.

**NOTE:** The tie straps were left untrimmed for clarity. Trim any excess from the tie straps once installed.



FIGURE 89





82. Continue to route the Body Length Jumper Harness along the LH frame rail. Once at the fuel tank, route the Body Length Jumper Harness across the crossbrace to the RH side of the frame rail on top of the fuel tank. Secure the Body Length Jumper Harness to the existing harness and to the holes within the crossbrace using the assorted supplied tie straps approximately every 12 in (305 mm). See Figures 90 and 91.

**NOTE:** The tie straps were left untrimmed for clarity. Trim any excess from the tie straps once installed.

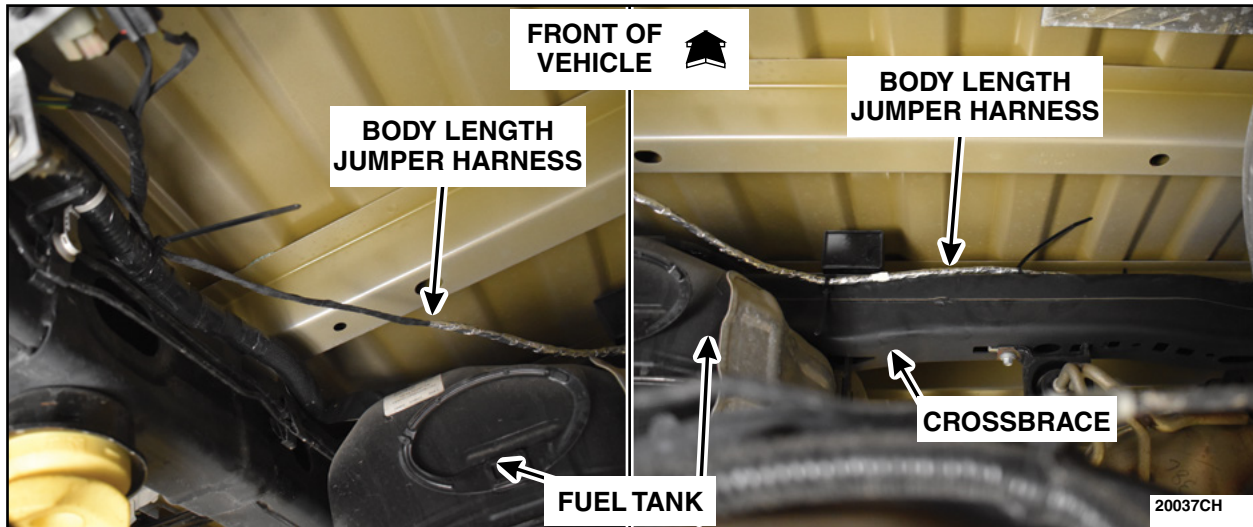

FIGURE 90

**NOTE:** The tie straps were left untrimmed for clarity. Trim any excess from the tie straps once installed.



FIGURE 91



83. Route the Body Length Jumper Harness over the RH frame rail and continue on the outboard RH frame rail as close to the bed as possible. Secure the Body Length Jumper Harness to the holes within the underside of the bed and to the outboard RH frame using the assorted supplied tie straps approximately every 12 in (305 mm). See Figure 92.

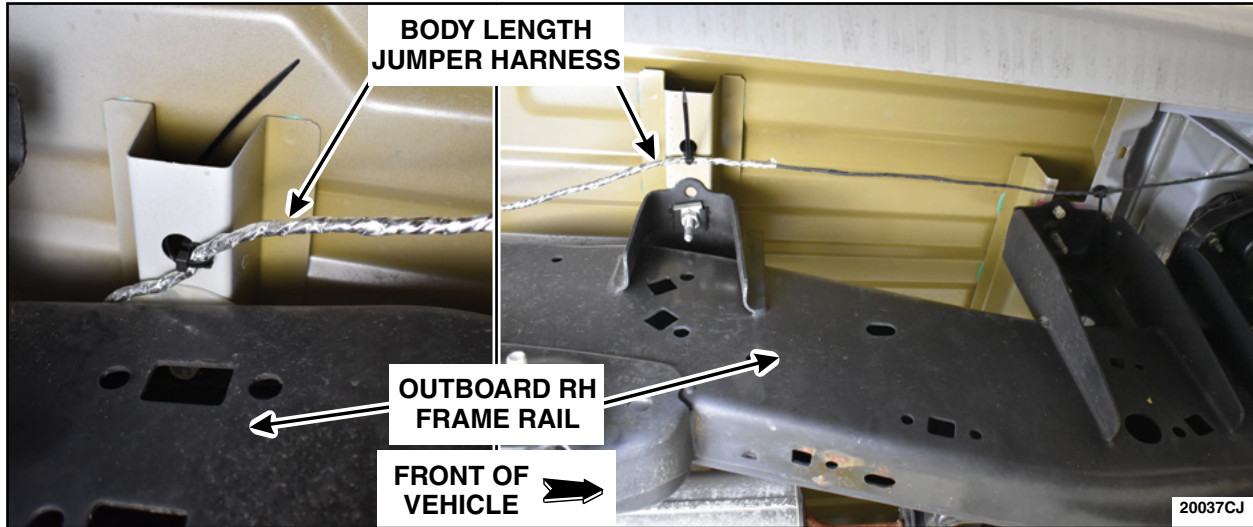

FIGURE 92

84. **Super Cab** vehicles have no hole present on the front passenger floorboard. **Crew cab** vehicles equipped WITH power running boards have a grommet located on the front passenger floorboard. **Crew Cab** vehicles WITHOUT power running boards have a plug on the front passenger floorboard. See Figure 93.

**For Super Cab** - Proceed to Step 85.

**For Crew Cab** - Proceed to Step 87.

**NOTE:** Floorboard grommet shown, floorboard plug similar.

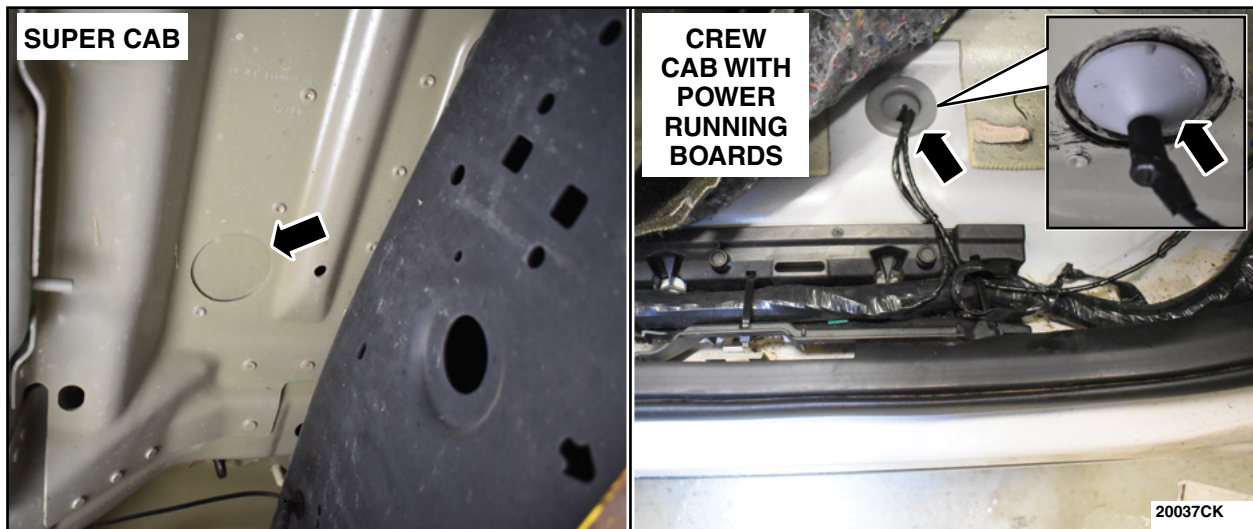

FIGURE 93



85. Locate the floorboard stamped circular hole on the under side of the front passenger floorboard. Using a Center Punch, mark the center of the circular hole. Using a 1-1/2 inch (38 mm) Bi-Metal Hole Saw with arbor and pilot bit, drill through the floorboard towards the inside of the vehicle. De-burr the hole. See Figure 94.

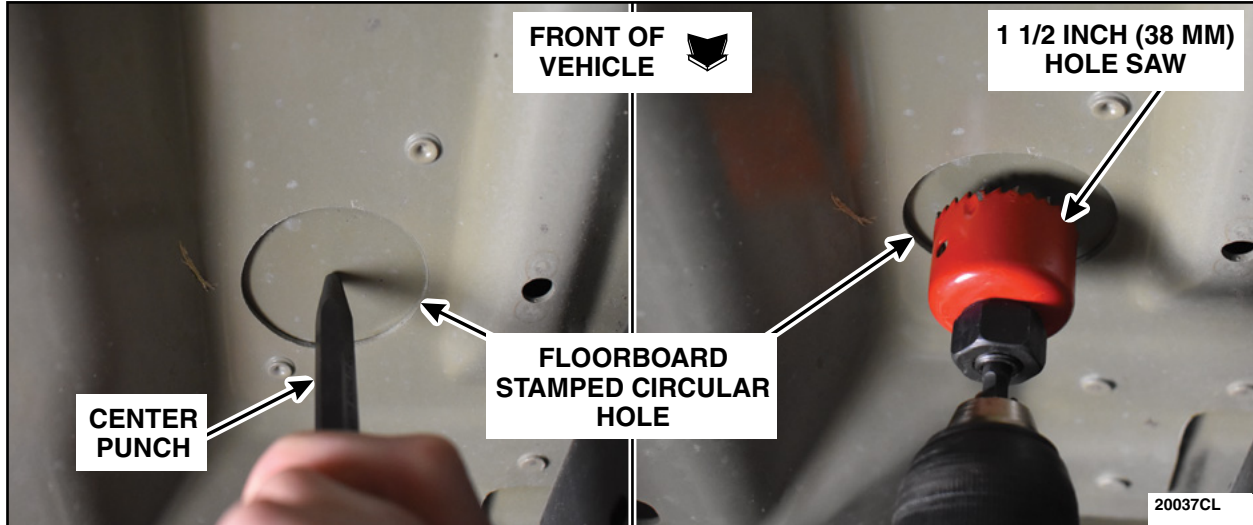

FIGURE 94

86. Following the directions on the can, liberally apply some PM-13-B Anti Corrosion Coating or equivalent to the edge and surface around the hole drilled into the floorboard. Allow to fully dry. See Figure 95.

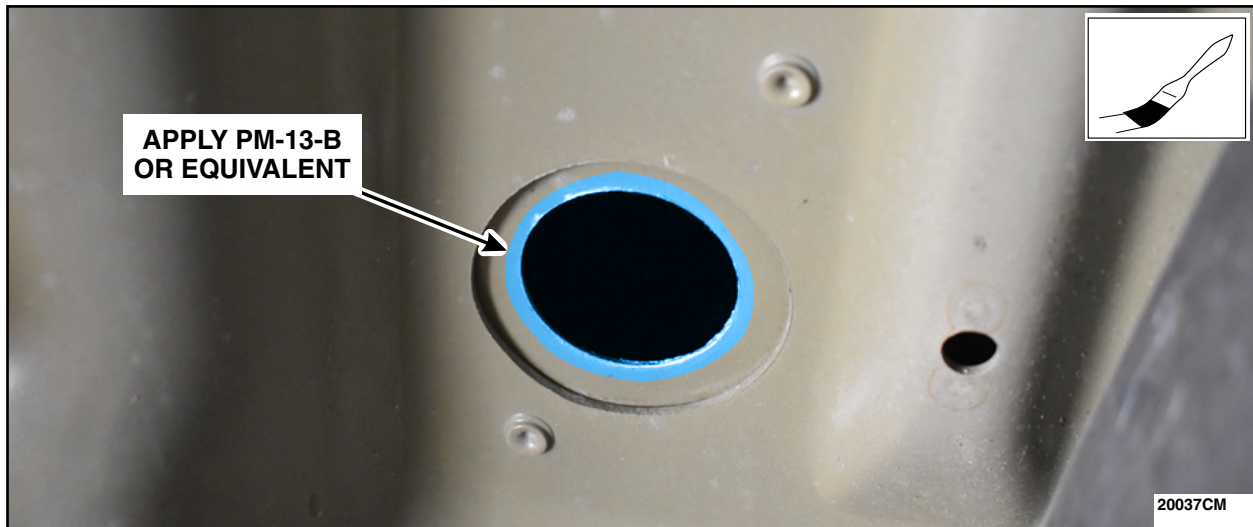

FIGURE 95





**NOTE:** For Crew Cab vehicles equipped with power running boards, the grommet will already be installed into the floorboard. If equipped with a body plug, remove and discard.

87. Install the grommet and route the Body Length Jumper Harness. See Figure 96.

- As needed, install the grommet included in the Tailgate Actuator Ground Wiring Part Kit into the hole drilled into the floorboard being sure that the grommet is fully seated.
  - a. **For Crew Cab vehicles equipped with power running boards**, remove the electrical tape off of the grommet that is already installed into the floorboard.
- Route the Body Length Jumper Harness through the center of the grommet.
  - b. **For Crew Cab vehicles equipped with power running boards**, route the Body Length Jumper Harness through the center of the existing grommet along side of the existing wire. See Figure 97.
- Apply black electrical tape over the end of the grommet and the Body Length Jumper Harness.

**NOTE:** Grommet on Crew Cab vehicle without power running boards shown, other similar.

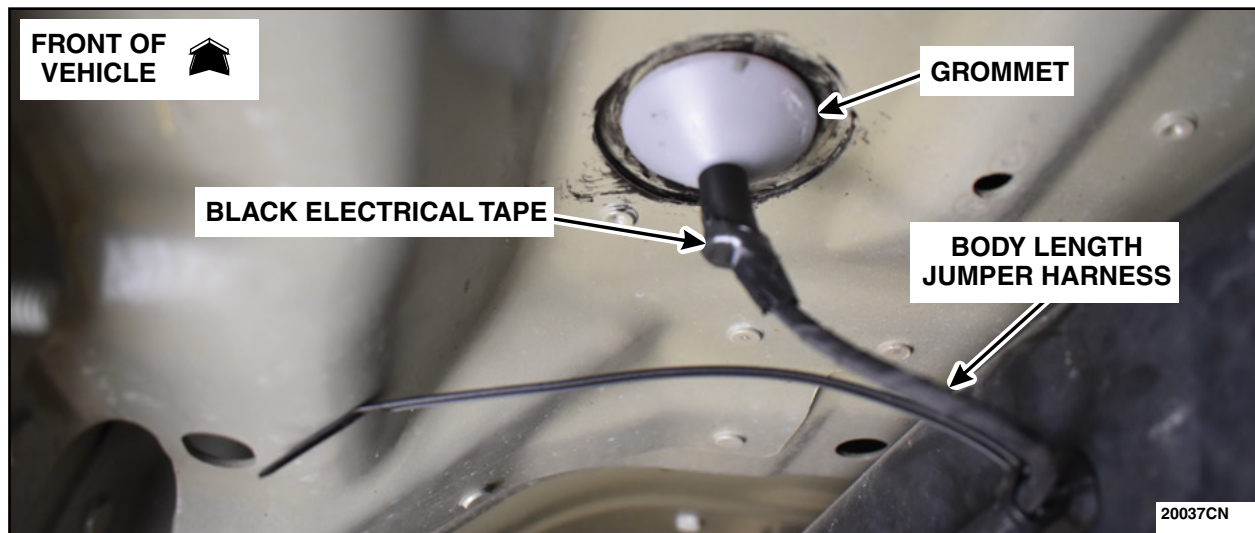
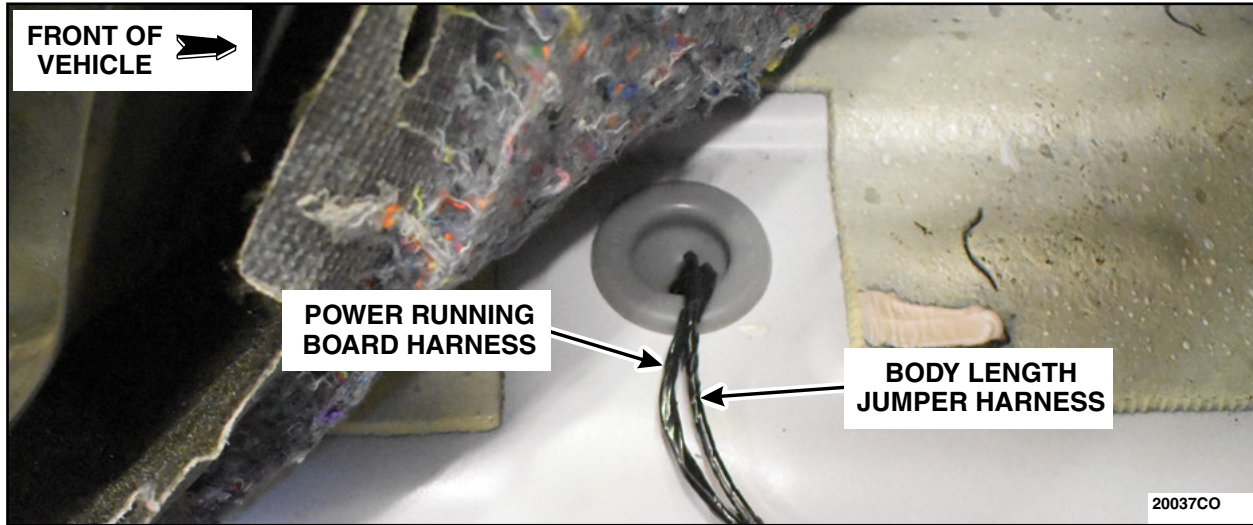

FIGURE 96





**NOTE:** Grommet on Crew Cab vehicle with power running boards shown, other similar.



**FIGURE 97**

88. Install the terminal from the Body Length Jumper Harness into pin 1 of the male end 2 pin connector.  
See Figure 98.

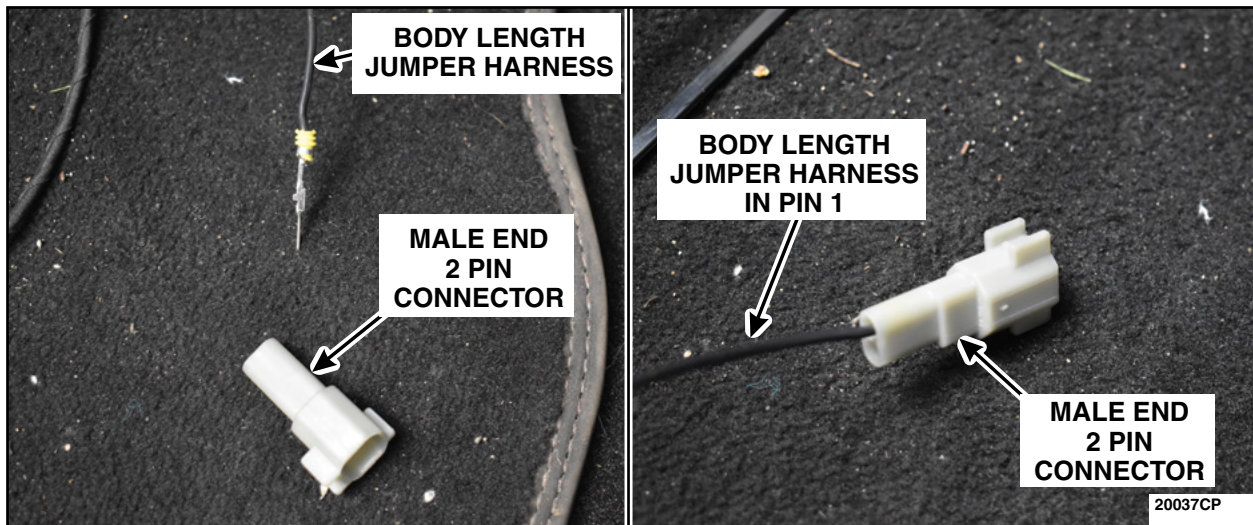

**FIGURE 98**



89. Engage the white locking tab. Connect the 2 cavity connector male end to the 2 cavity connector female end from the relay. See Figure 99.

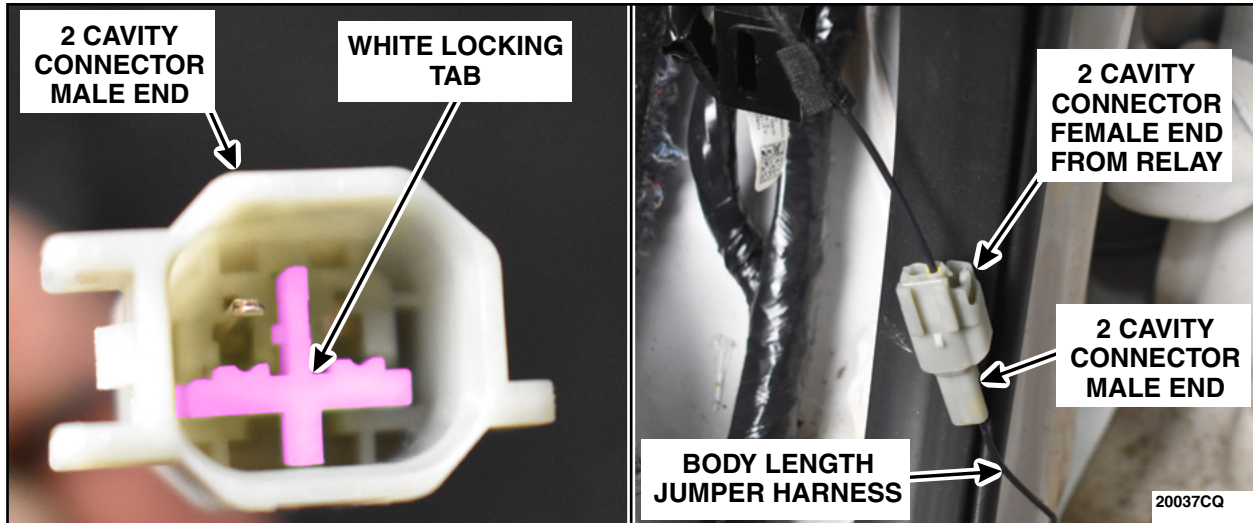

FIGURE 99

90. Secure the 2 cavity connector to a wiring harness near the 3 connectors in the glove compartment area. Secure the excess Body Length Jumper Harness to the wiring harness below the BCM using a tie strap. See Figure 100.

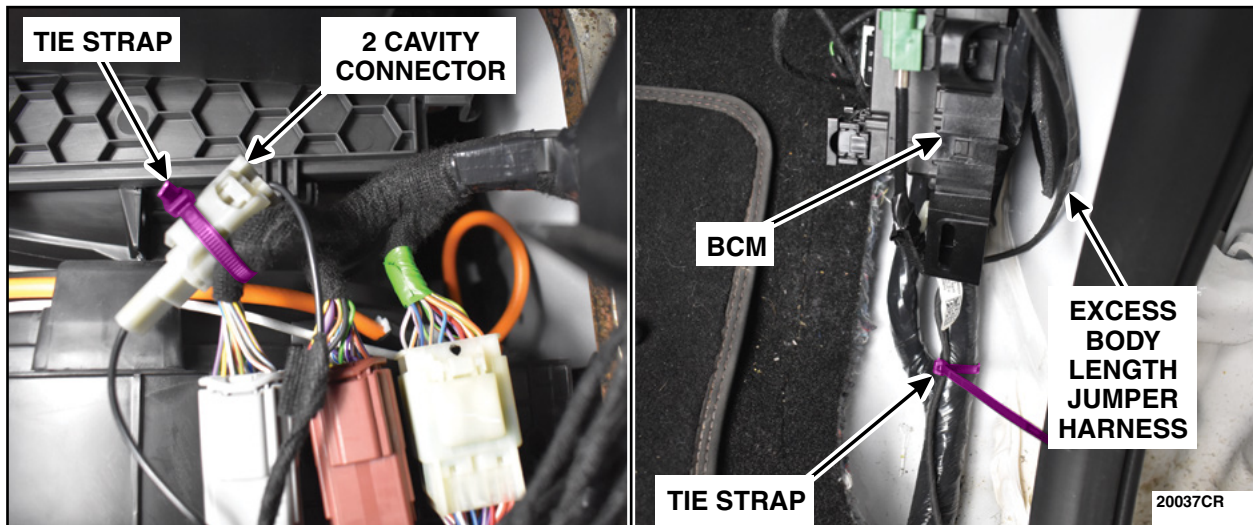

FIGURE 100



91. Install the Glove Compartment. Please follow the WSM procedures in Section 501-12.

92. Install the RH Instrument Panel Finish Panel. Position back the weatherstrip. See Figure 101.

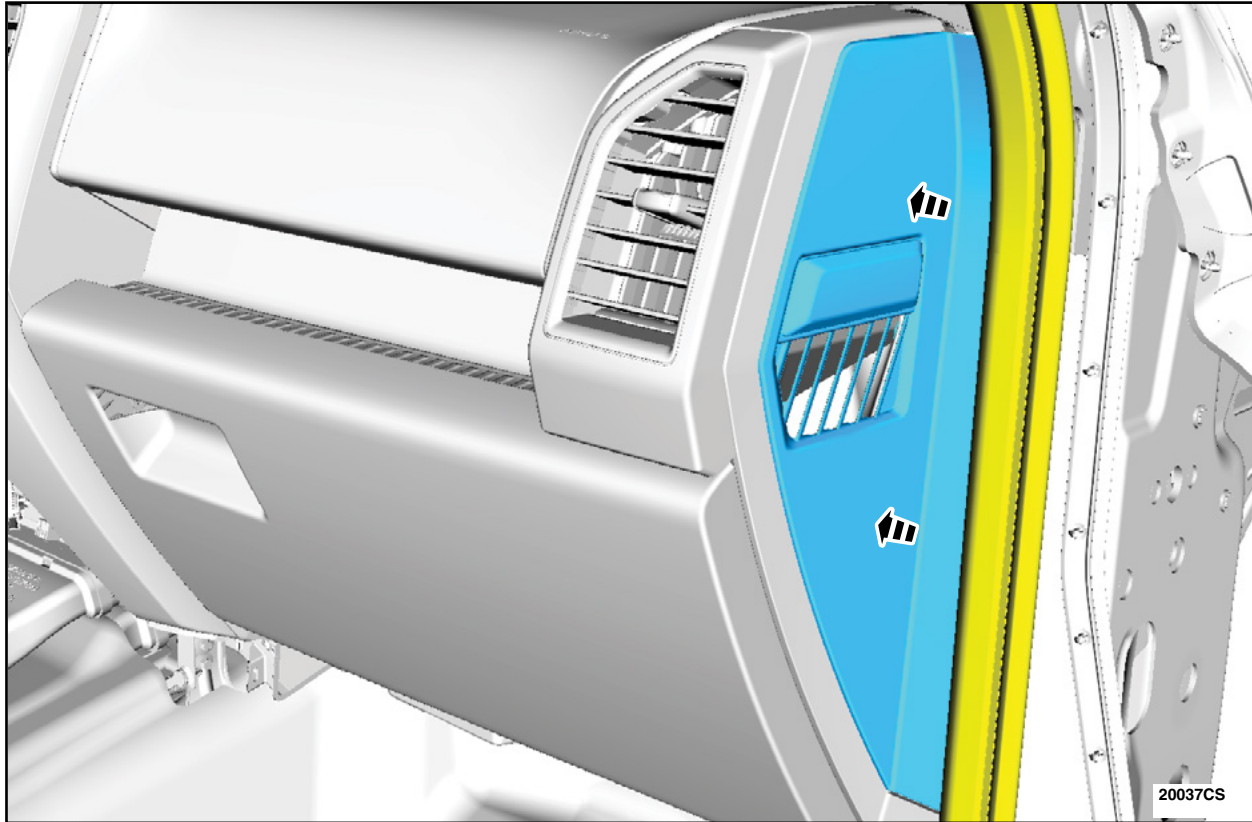

FIGURE 101





93. Position back the RH front carpet. See Figure 102.

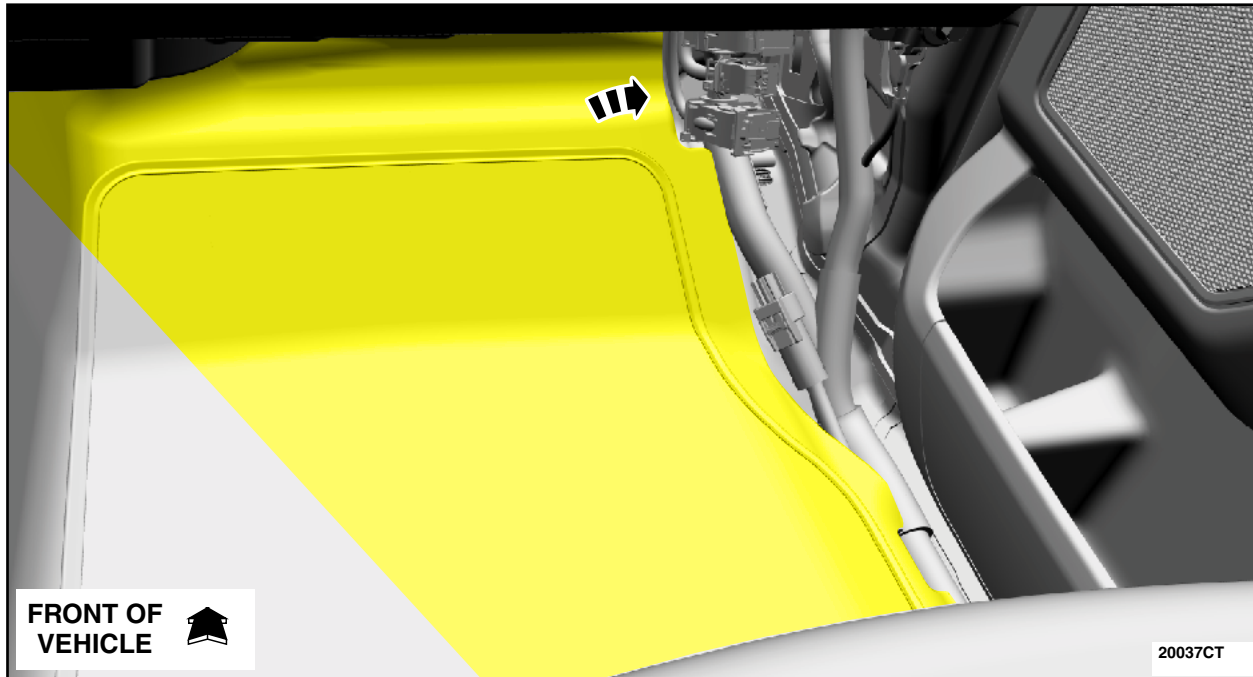

FIGURE 102

94. Install the RH Lower Cowl Trim Panel and the Fuse Panel Cover. See Figure 103.

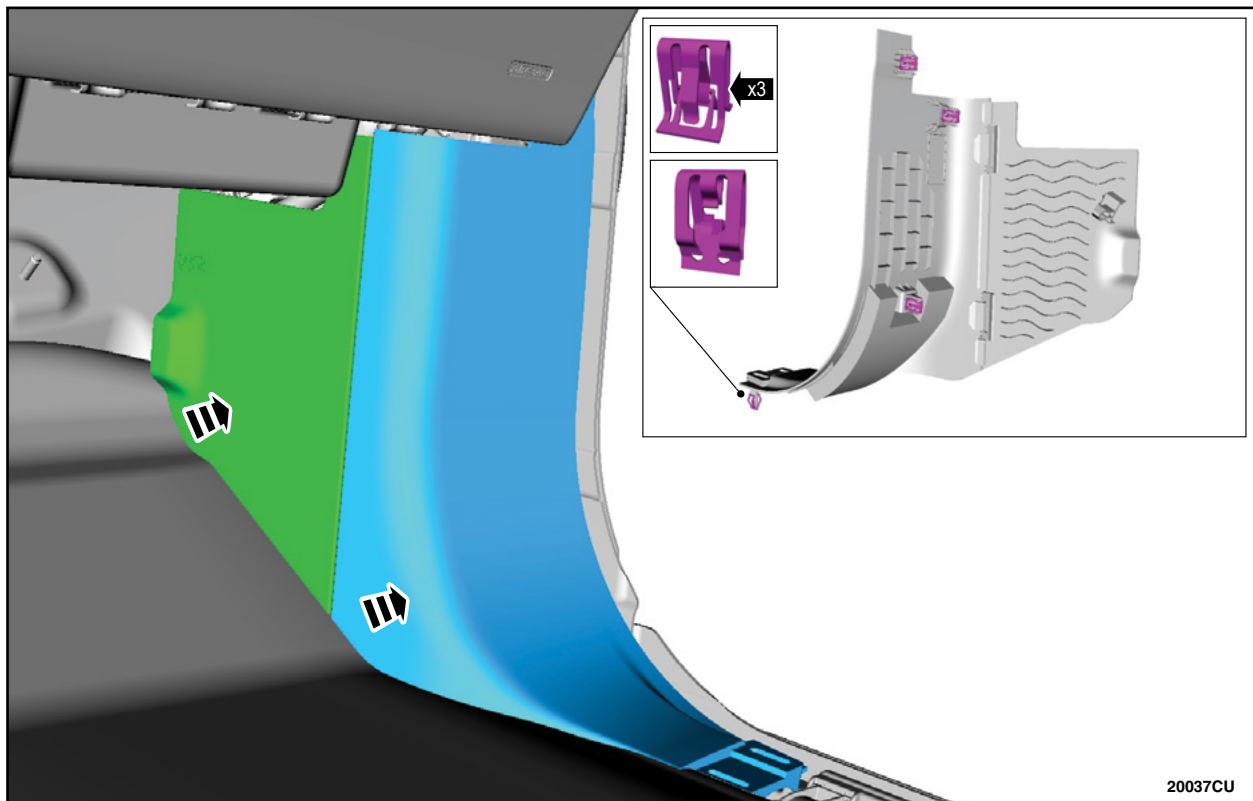

FIGURE 103



95. Remove the ratchet strap and raise the spare tire and replace the spare tire rod inside the vehicle.
96. Install the RH Front Scuff Plate Trim Panel. Please follow the WSM procedure in Section 501-05.
97. Connect the negative battery cable(s). Please follow the WSM procedures in Section 414-01.

### Module Reprogramming

**NOTE:** Reprogram appropriate vehicle modules before performing diagnostics and clear all Diagnostic Trouble Codes (DTC's) after programming. For DTC's generated after reprogramming, follow normal diagnostic service procedures.

1. Connect a battery charger to the 12V battery.

**NOTE:** Verify that the negative cable of the charger is installed on a chassis or engine ground, and not the 12 volt battery negative terminal to prevent the battery saver mode from activating on the vehicle.

**NOTE:** Make sure the Integrated Diagnostic Software (IDS) computer does not enter sleep mode during programming.

2. Reprogram the BCM using IDS release 128.01 or higher. Make sure you are connected to the Internet prior to reprogramming.

**NOTE:** Calibration files may also be obtained at [www.motorcraftservice.com](http://www.motorcraftservice.com).

**NOTE:** Follow the IDS on-screen instructions to complete the reprogramming procedure.

3. Under "Programmable Parameters" select "Vehicle". Then when prompted with the "Tailgate Release Switch" choose option "Double Press". Select the tick.
4. Under "Programmable Parameters" select "Vehicle". Then when prompted with "BTSI Relay". Choose option "Installed". Select the tick.
5. If available, under "Programmable Parameters" select "Vehicle". Then when prompted with "Tailgate Ajar Message". Choose option "indicator - Off/Disable". Select the tick.
6. Disconnect the battery charger from the 12V battery once the reprogramming has completed.



## Important Information for Module Programming

**NOTE:** When programming or reprogramming a module, use the following basic checks to ensure programming completes without errors.

- Make sure the 12V battery is fully charged before carrying out the programming steps and connect IDS/scan tool to a power source.
- Inspect Vehicle Communication Module (VCM) and cables for any damage. Make sure scan tool connections are not interrupted during programming.
- A hardwired connection is strongly recommended.
- Turn off all unnecessary accessories (radio, heated/cooled seats, headlamps, interior lamps, HVAC system, etc.) and close doors.
- Disconnect/depower any aftermarket accessories (remote start, alarm, power inverter, CB radio, etc.).
- Follow all scan tool on-screen instructions carefully.
- Disable IDS/scan tool sleep mode, screensaver, hibernation modes.
- Create all sessions Key ON Engine OFF (KOEO). Starting the vehicle before creating a session will cause errors within the programming inhale process.

## Recovering a module when programming has resulted in a blank module: **NEVER DELETE THE ORIGINAL SESSION!**

- a. Obtain the original IDS that was used when the programming error occurred during Module Reprogramming (MR) or Programmable Module Installation (PMI).
- b. Disconnect the VCM from the Data Link Connector (DLC) and the IDS.
- c. Reconnect the VCM to IDS and then connect to the DLC. Once reconnected, the VCM icon should appear in the corner of the IDS screen. If it does not, troubleshoot the IDS to VCM connection.
- d. Locate the original vehicle session when programming failed. This should be the last session used in most cases. If not, use the session created on the date that the programming failed.

**NOTE:** If the original session is not listed in the previous session list, click the Recycle Bin icon at the lower right of the previous session screen. This loads any deleted sessions and allows you to look through them. Double-click the session to restore it.

- e. Once the session is loaded, the failed process should resume automatically.
- f. If programming does not resume automatically, proceed to the Module Programming menu and select the previously attempted process, PMI or MR.
- g. Follow all on-screen prompts/instructions.
- h. The last screen on the IDS may list additional steps required to complete the programming process. Make sure all applicable steps listed on the screen are followed in order.

**IMPORTANT NOTE: Federal law prohibits selling motor vehicle parts or components that are under safety, compliance, or emissions recall. Unless a part is requested to be returned to Ford, all parts replaced under this FSA must be scrapped in accordance with all applicable local, state and federal environmental protection and hazardous material regulations. Refer to the Parts Retention, Return, & Scrapping section of the FSA dealer bulletin for further information.**







Ford Motor Company  
Ford Customer Service Division  
P. O. Box 1904  
Dearborn, Michigan 48121

## Customer Satisfaction Program 21M06

Mr. John Sample  
123 Main Street  
Anywhere, USA 12345

November 2022

Your Vehicle Identification Number (VIN): 12345678901234567

Ford Motor Company is committed to building a community of happy, satisfied customers. To demonstrate that commitment, we are providing a no-charge program for your vehicle with the VIN shown above.

### **Why are you receiving this notice?**

Ford Motor Company launched program 21M06 for customers who have previously repaired their power release tailgate and continue to experience unintended tailgate opening and would like an enhanced repair. 21M06 also is available to customers that have not received a tailgate repair and would like to have the enhanced repair. We are pleased to let you know that, for your peace of mind, Ford Motor Company will provide enhanced repairs (if needed) on the power release tailgate system.

### **What is the effect?**

This repair of the power release tailgate system will be available for a total of 10 years or 150,000 miles from the warranty start date, whichever occurs first.

If your vehicle has already exceeded either time or mileage limits listed above, this repair offer will last through May 2023. Coverage is automatically transferred to subsequent owners.

### **What will Ford and your dealer do?**

**Parts are now available to repair your vehicle.** If you have experienced unintended tailgate opening, and your vehicle is within the indicated time/mileage limitations, Ford Motor Company has authorized your dealer to modify the power release tailgate system wiring, install a new tailgate handle release switch and update the Body Control Module software free of charge (parts and labor).

### **How long will it take?**

The time needed for this repair is less than one-half day. However, due to service scheduling requirements, your dealer may need your vehicle for a longer period of time.

### **What should you do?**

If you have experienced unintended tailgate opening, please contact your dealer and provide the VIN of your vehicle to schedule a service appointment for Customer Satisfaction Program 21M06.

**What should you do?  
(continued)**

The VIN is printed near your name at the beginning of this letter. Your dealer will modify the power release tailgate system wiring, install a new tailgate handle release switch and update the Body Control Module software free of charge (parts and labor).

As always, please remember to secure any cargo in the truck bed. If you feel you have experienced unintended tailgate opening resulting in damage to your vehicle, please contact your dealer for an inspection of the damage to be considered for repair approval.

If you do not already have a servicing dealer, you can access [ford.com/support](https://ford.com/support) for dealer addresses, maps, and driving instructions.

NOTE: You can receive information about Recalls and Customer Satisfaction Programs through our FordPass App. The app can be downloaded through the App Store or Google Play. In addition there are other features such as reserving parking in certain locations and controlling certain functions on your vehicle (lock or unlock doors, remote start) if it is equipped to allow control.

**Have you previously paid for this repair?**

If you paid to have repairs done for an unintended tailgate opening concern, you may be eligible for a refund. Refunds will only be provided for service related to the concern description. To verify eligibility and expedite reimbursement, give your paid original receipt to your dealer before **May 31, 2023**. To avoid delays, do not send receipts to Ford Motor Company.

**What if you no longer own this vehicle?**

If you no longer own this vehicle, and have an address for the current owner, please forward this letter to the new owner. You received this notice because our records indicate that you are the current owner.

**Can we assist you further?**

If you have difficulties getting your vehicle repaired promptly and without charge, please contact your dealership's Service Manager for assistance.

RETAIL OWNERS: If you have questions or concerns, please contact our **Ford Customer Relationship Center at 1-866-436-7332** and one of our representatives will be happy to assist you. If you wish to contact us through the Internet, our address is: [ford.com/support](https://ford.com/support).

For the hearing impaired, call 1-800-232-5952 (TDD). Representatives are available Monday through Friday: 8:00AM - 8:00PM (Eastern Time).

FLEET OWNERS: If you have questions or concerns, please contact our **Ford Pro Contact Center at 1-800-34-FLEET**, choose Option #1, and one of our representatives will be happy to assist you. If you wish to contact us through the Internet, our address is: [fleet.ford.com](https://fleet.ford.com).

Representatives are available Monday through Friday: 7:00AM - 11:00PM and Saturday 7:00AM – 5:00PM (Eastern Time).

As part of the Ford community, we appreciate your attention to this important matter and your continued loyalty.

Ford Customer Service Division



**Customer Satisfaction Program, Unintended Tailgate Opening  
2015-2020 Model Year F-150 Vehicles  
Customer Information Sheet**

Thank you for having Customer Satisfaction Program 21M06 completed on your vehicle.

Improvements have been made to your vehicle's electronic tailgate system to prevent unintended tailgate opening. These include the following software updates:

- The vehicle must be in park (P) to operate the power release tailgate
- To open the power release tailgate from the interior of the vehicle, press the button on the instrument panel (if equipped) twice within three seconds
- To open the power release tailgate from the exterior, press the button in the top of the tailgate handle twice within three seconds

Your vehicle was designed with multiple ways to open the tailgate. Please be aware that certain factors can cause your tailgate to appear to be closed, although it may not be fully latched.

Please remember to ensure that your tailgate is closed prior to driving. For further information regarding electronic tailgate operation, please refer to your vehicle Owner Manual.

Please keep this letter with your vehicle's Owner Manual for future reference.

Sincerely,  
Ford Motor Company



## Owner's Manual Addendum

Please insert this page in your Owner's Manual.

### **Tailgate - Vehicles With: Remote Power Tailgate Release/Remote Release Tailgate**

The following information supplements your Owner's Manual. For any questions regarding the tailgate, contact an authorized dealer.

#### **OPENING THE TAILGATE FROM INSIDE YOUR VEHICLE**

The vehicle must be in park (P) to operate the power tailgate.

Press the button on the instrument panel twice within three seconds.



**Note:** A tone sounds when the tailgate opens.

#### **OPENING THE TAILGATE FROM OUTSIDE YOUR VEHICLE**

1. Unlock the vehicle with the remote control or power door unlock button.

**Note:** If an intelligent access transmitter is within 1 m (3 ft) of the tailgate, the tailgate unlocks when you press the tailgate release button.

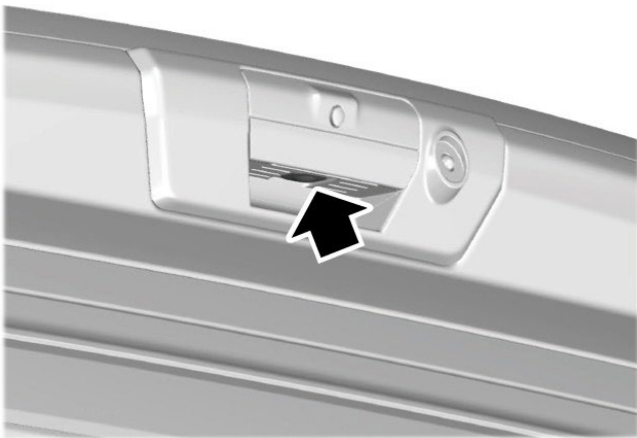

2. Press the button in the top of the tailgate handle twice within three seconds.