

ATTENTION:

- GENERAL MANAGER
- PARTS MANAGER
- CLAIMS PERSONNEL
- SERVICE MANAGER

IMPORTANT - All Service Personnel Should Read and Initial in the boxes provided, right.

© 2022 Subaru of America, Inc. All rights reserved.



QUALITY DRIVEN® SERVICE

SERVICE PROGRAM BULLETIN

APPLICABILITY: 2022 MY WRX

NUMBER: WRB-22

SUBJECT: PCV Vacuum Hose Clamp Lock Failure

DATE: 07/18/22

In the interest of customer satisfaction, Subaru of America, Inc. (Subaru) is initiating a new voluntary emissions recall for certain 2022 model year WRX vehicles equipped with a 2.4L turbo engine.

REASON FOR THIS VOLUNTARY EMISSIONS RECALL

The affected vehicles may contain a hose clamp securing the upper connection of the PCV vacuum hose (blow-by hose) which may not have been fully locked during assembly.

DESCRIPTION OF THE REPAIR

Subaru retailers will inspect the hose clamp securing the upper connection of the PCV vacuum hose (blow-by hose) and, if necessary, adjust the hose clamp to a fully locked condition at no cost to the customer.

Affected Vehicles

The number of U.S. vehicles included in this service program is 5,837.

Model Year	Carline	Production date range
2022	WRX	January 21, 2022 – May 12, 2022

Not all vehicles in the production date range listed above may be included in this voluntary emissions recall. Coverage for all affected vehicles must be confirmed by using the Vehicle Coverage Inquiry function on subarunet.com.

Retailer Responsibility

Please be advised that it is a violation of Federal law for a dealer to deliver a new motor vehicle covered by a recall under a sale or lease until the defect is remedied. Therefore, any Authorized Subaru Retailer failing to perform the applicable service procedures to correct all affected vehicles in their inventory prior to the vehicle being placed in service may be subject to civil penalties of up to \$22,423 per violation (i.e., for each vehicle), as provided in 49 CFR §578.6 and will also be in breach of the Subaru Dealer Agreement.

CAUTION: VEHICLE SERVICING PERFORMED BY UNTRAINED PERSONS COULD RESULT IN SERIOUS INJURY TO THOSE PERSONS OR TO OTHERS.

Subaru Service Bulletins are intended for use by professional technicians ONLY. They are written to inform those technicians of conditions that may occur in some vehicles, or to provide information that could assist in the proper servicing of the vehicle. Properly trained technicians have the equipment, tools, safety instructions, and know-how to do the job correctly and safely. If a condition is described, DO NOT assume that this Service Bulletin applies to your vehicle, or that your vehicle will have that condition.

Subaru of America, Inc. is ISO 14001 Compliant

ISO 14001 is the international standard for excellence in Environmental Management Systems. Please recycle or dispose of automotive products in a manner that is friendly to our environment and in accordance with all local, state and federal laws and regulations.

Continued...

Any vehicles listed in any recall/campaign that are in retailer stock must be:

- Immediately identified
- Tagged or otherwise marked to prevent their delivery or use prior to repair
- Repaired in accordance with the repair procedures outlined in the bulletin

Retailers are to promptly perform the applicable service procedures, to correct all affected vehicles in their inventory (used, demo & SSLP). Whenever a vehicle subject to this voluntary emissions recall is taken into retailer inventory necessary steps should be taken to ensure the correction has been made before selling or releasing the vehicle.

Owner Notification

Subaru will notify affected vehicle owners by first class mail in August. Retailers will be advised when the notification is scheduled.

DESCRIPTION OF CONCERN:

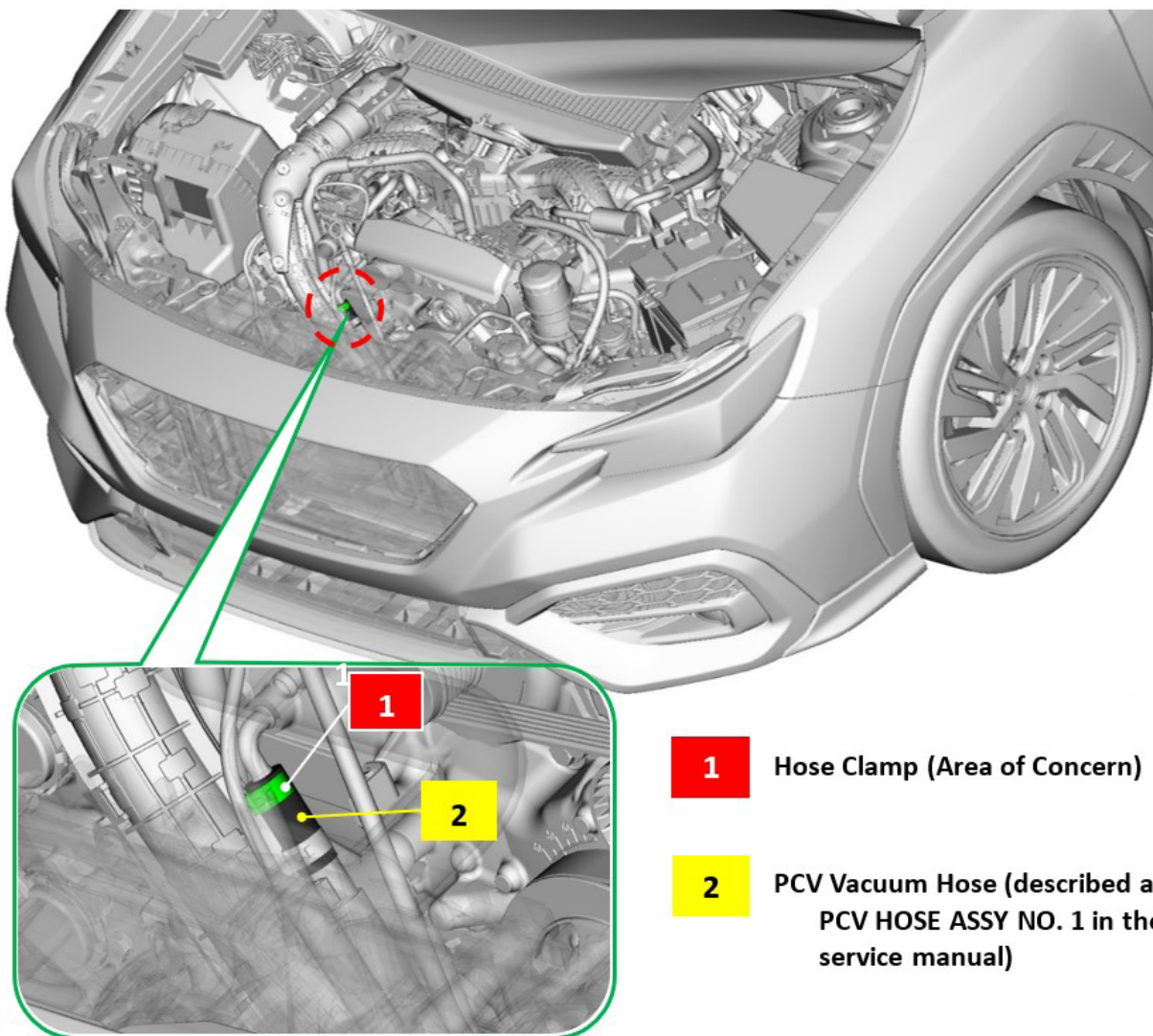

Continued...

PART INFORMATION:

REMINDER: Always order the most up-to-date replacement parts based on the specific VIN being repaired.

Part Description	Part Number
HOSE CLAMP	805919150

IMPORTANT NOTE: The hose clamp will **ONLY** require replacement if it is found to have excessive damage and cannot be secured.

REQUIRED TOOLS:

35-45° Bent Long-Neck Needle Nose Pliers will be required to perform the procedures outlined below.

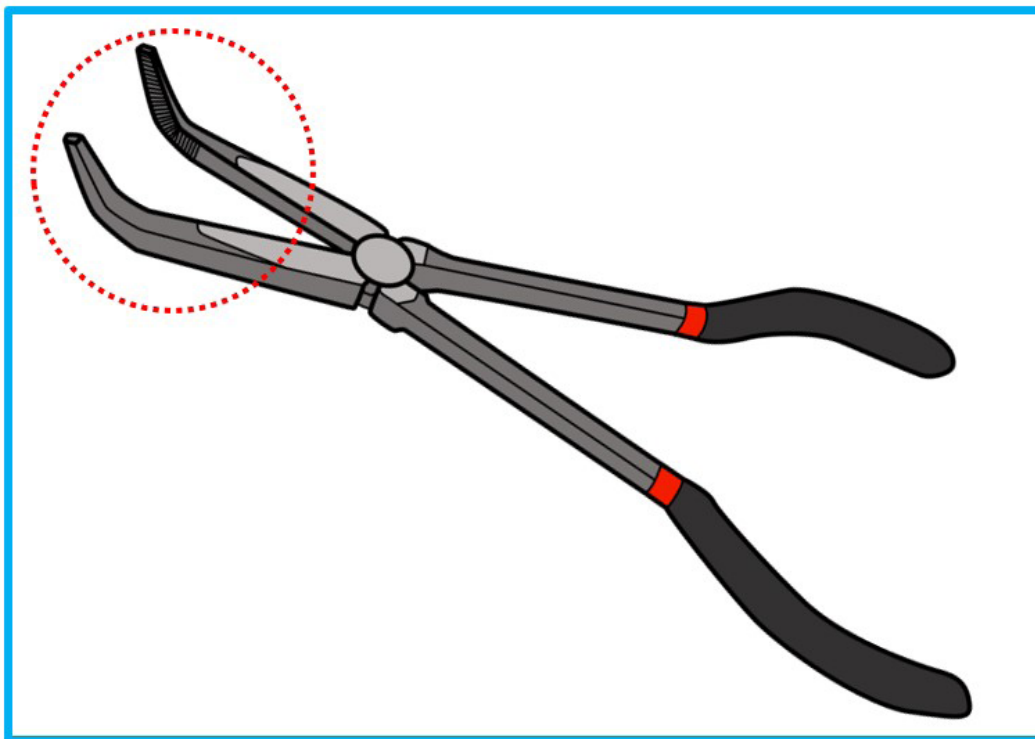

NOTE: The Snap On® 11" Talon Grip™ Long-Neck 35° Bent Needle Nose Pliers (#411CF) are a usable suggestion.

Continued...

SERVICE PROCEDURE OUTLINE:

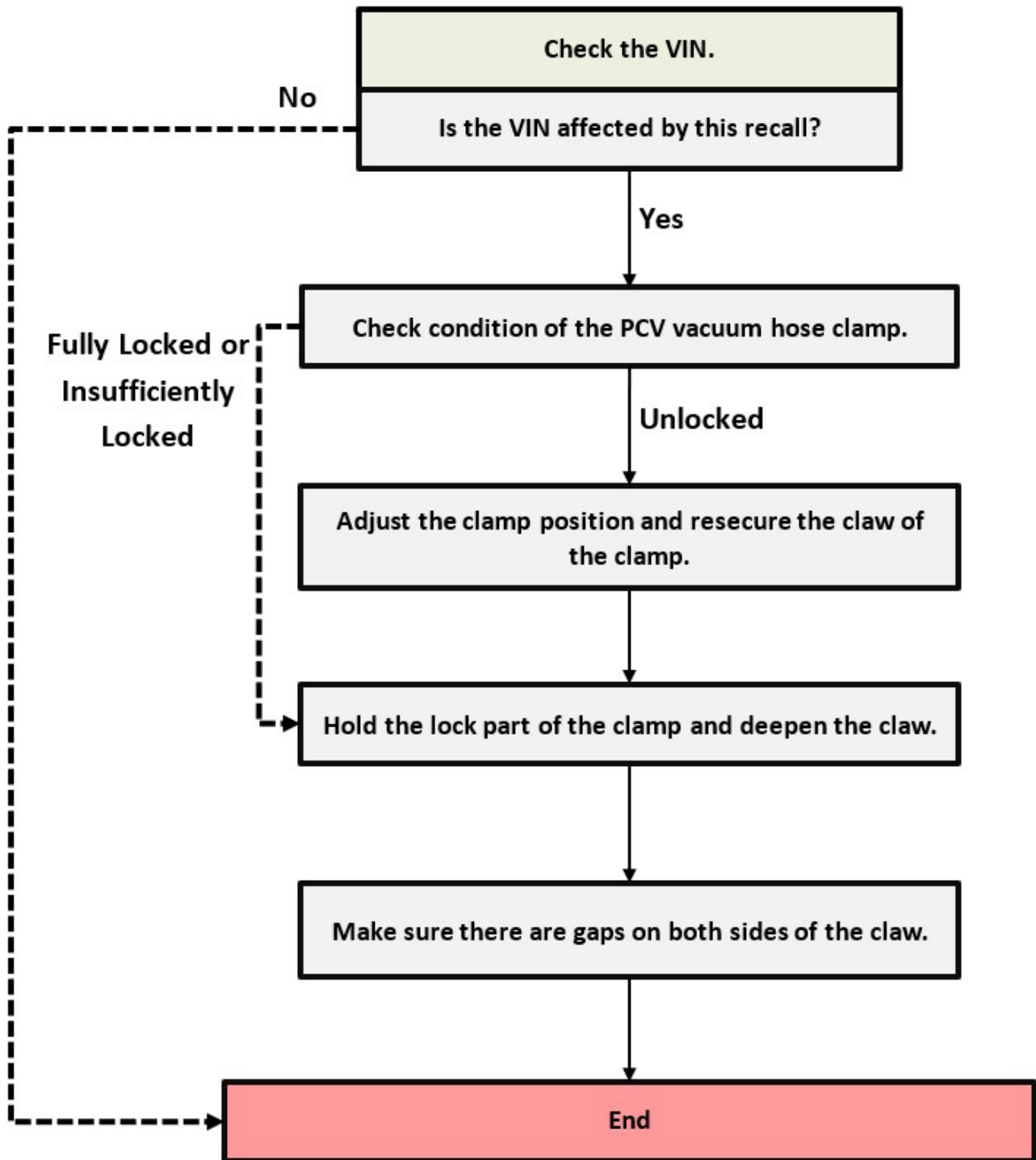

Continued...

SERVICE PROCEDURE / INFORMATION:

REMINDER: Customer satisfaction and retention starts with performing quality repairs.

STEP 1: Remove the two mounting fasteners and then removed the intake duct.

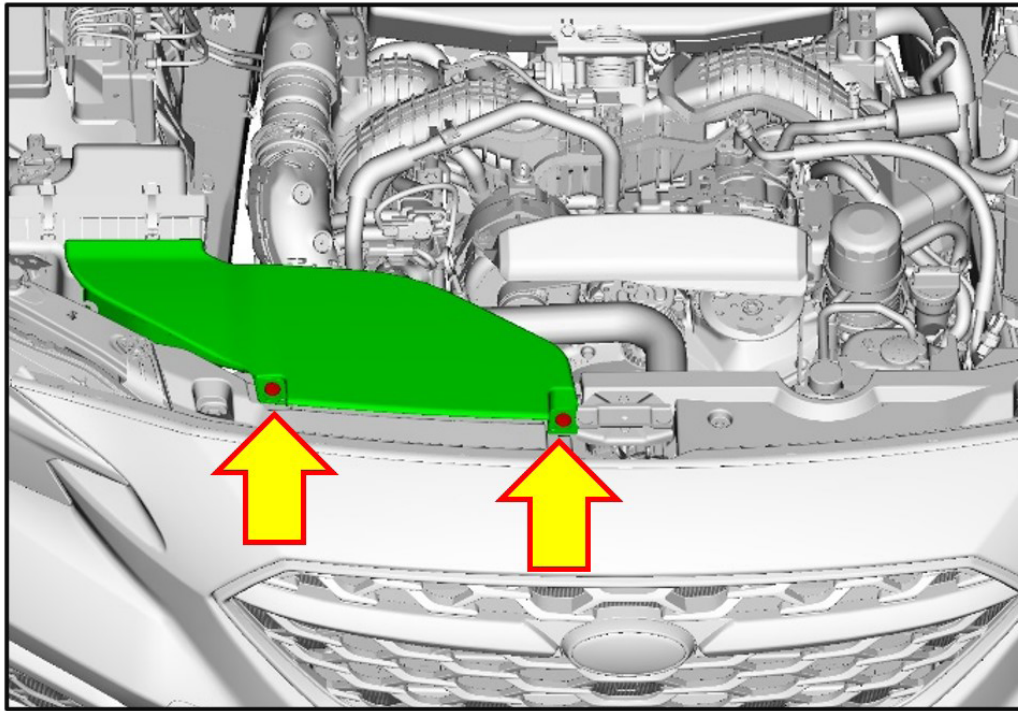

STEP 2: Perform a visual inspection of the hose clamp claw positioning from the small opening within the clamp.

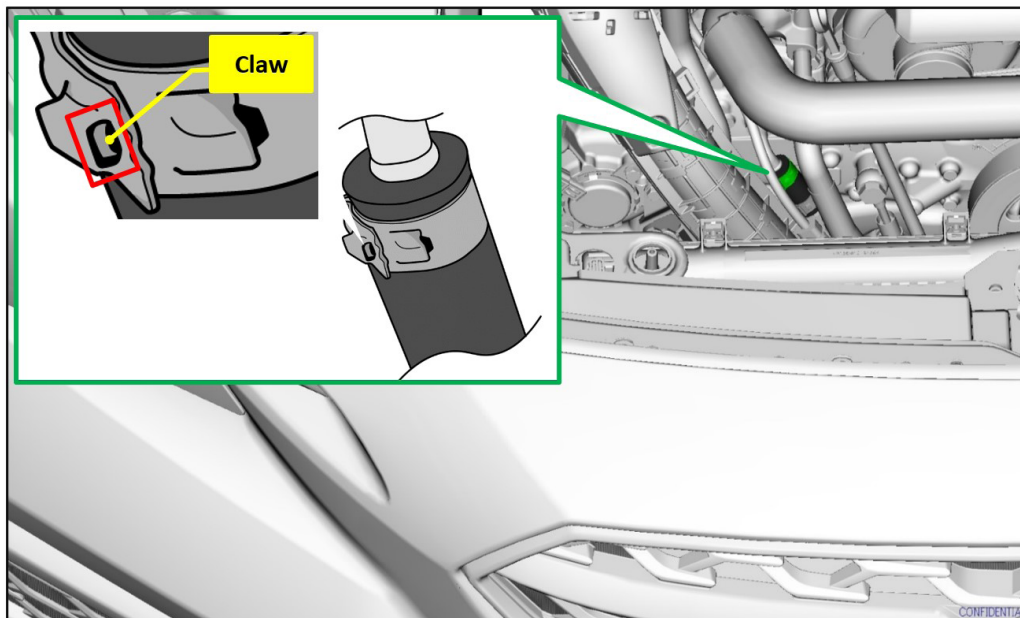

Continued...

Examples of Hose Clamp Claw Conditions

IMPORTANT NOTE: The hose clamp direction may be in the opposite direction of those pictured in the examples below.

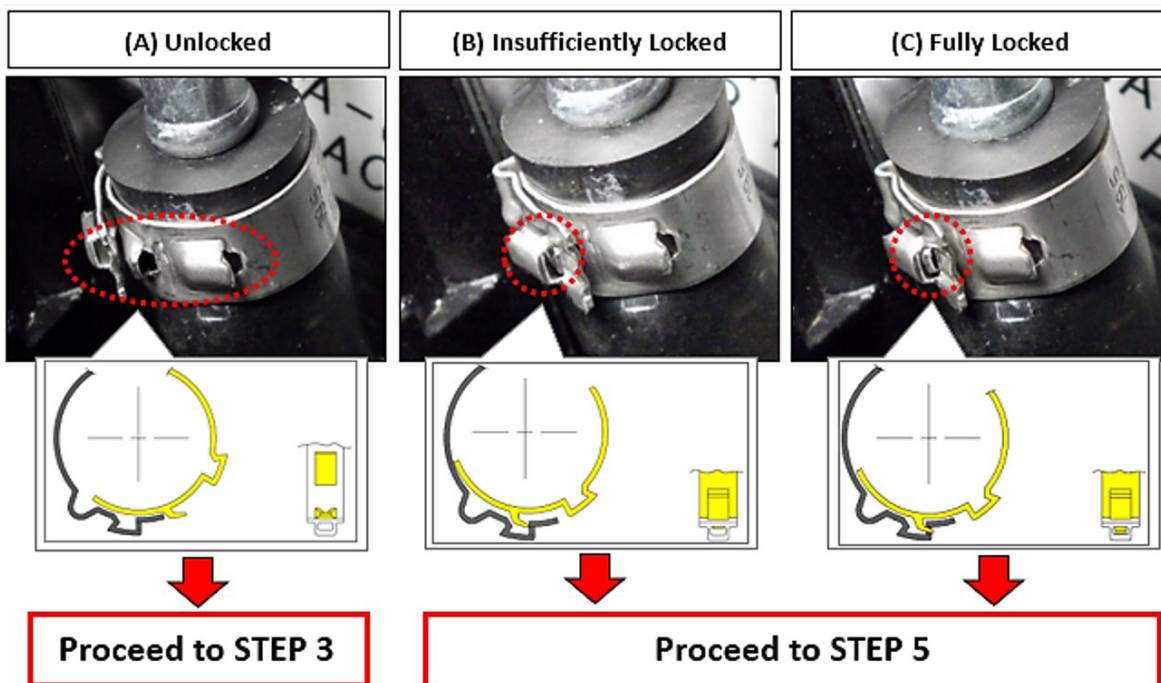

STEP 3: Adjusting the hose clamp position.

- Position the clamp evenly 3mm (0.12 inch) from the top the hose.
- Make sure the lock portion is facing the front of the vehicle.

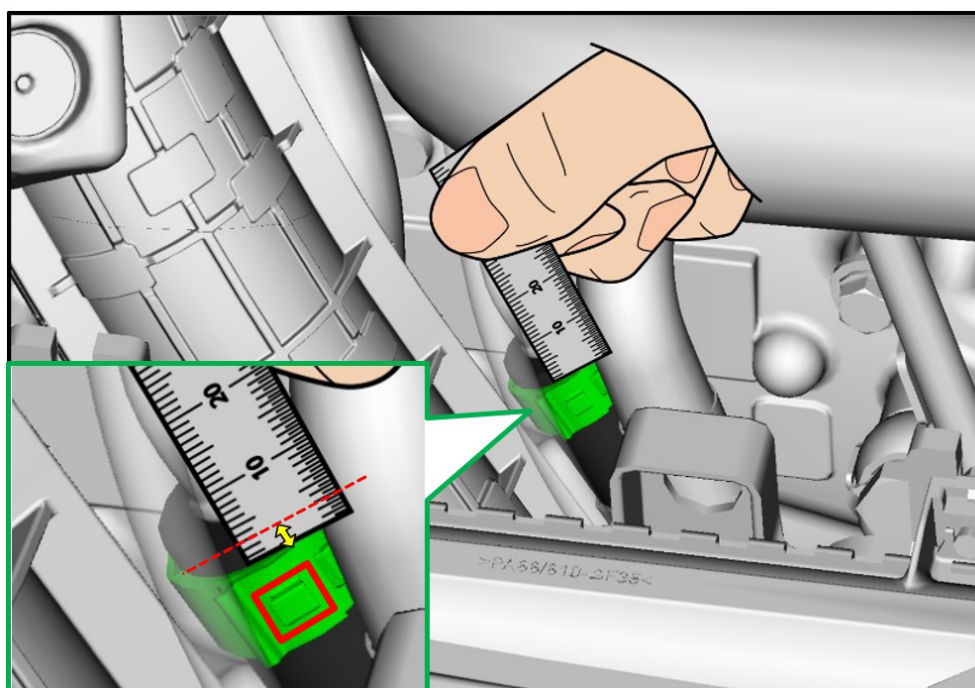

Continued...

STEP 4: Using 35-45° bent long-neck needle nose pliers, squeeze the clamp at the two points indicated with arrows below. Confirm the lock portion is hooked properly onto the claw.

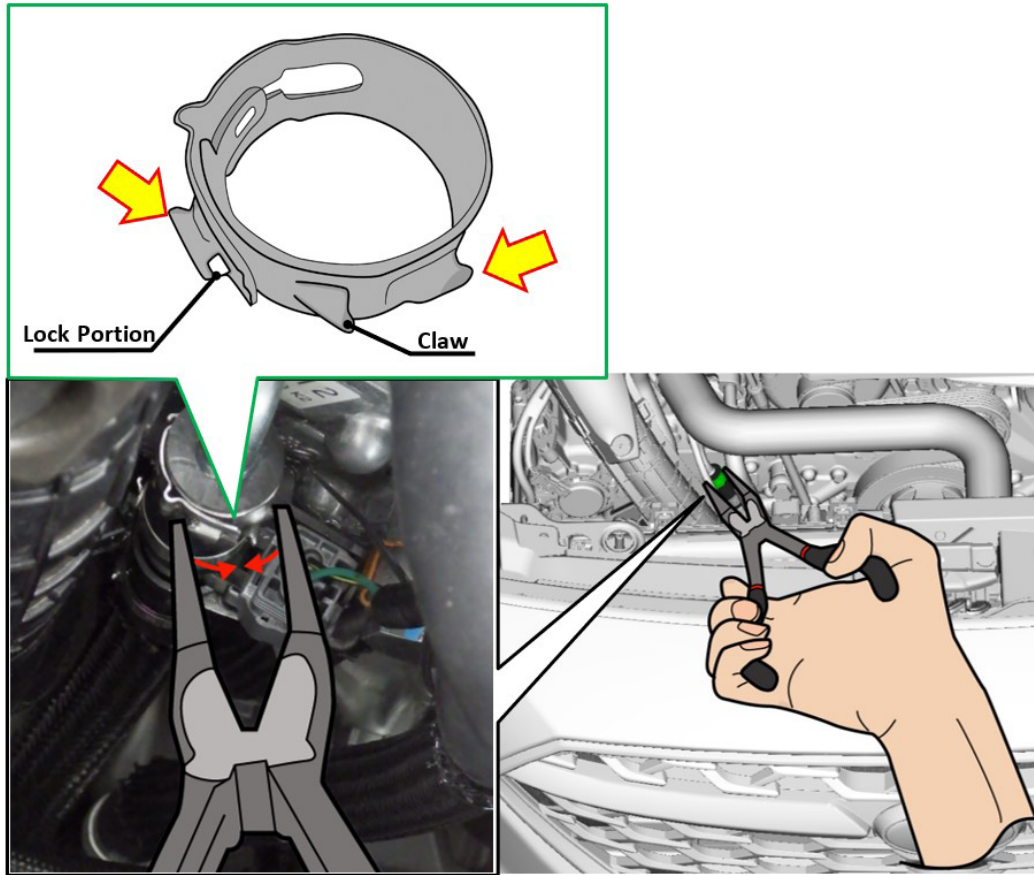

STEP 5: Using 35-45° bent long-neck needle nose pliers, squeeze the lock portion of the clamp, and confirm it is fully locked.

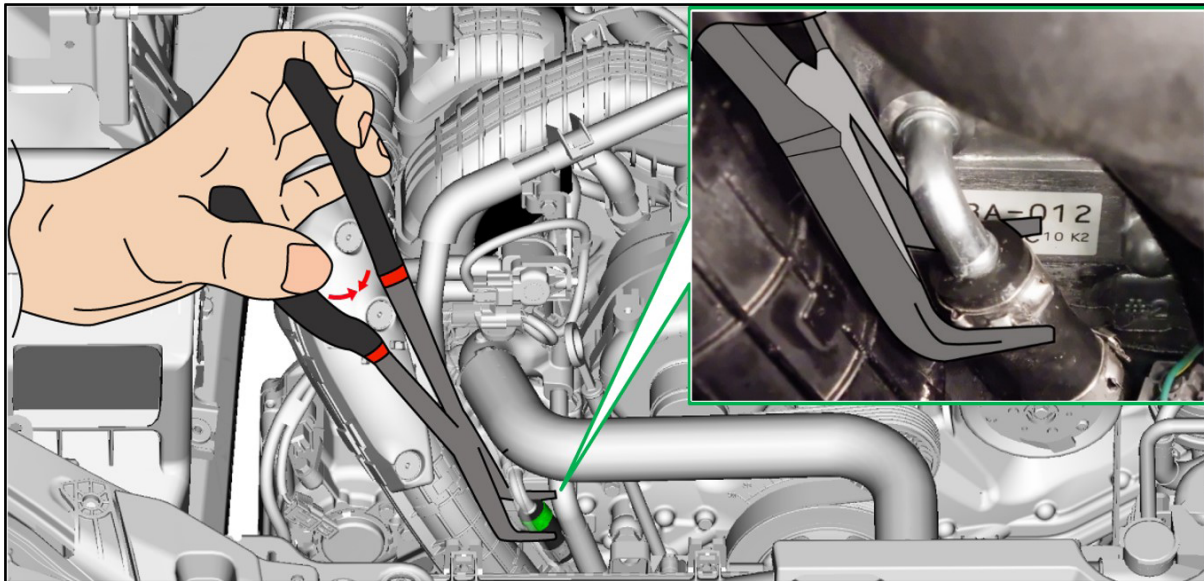

Continued...

STEP 6: Confirm the clamp is fully locked by visually inspecting the claw position as shown in the image below.

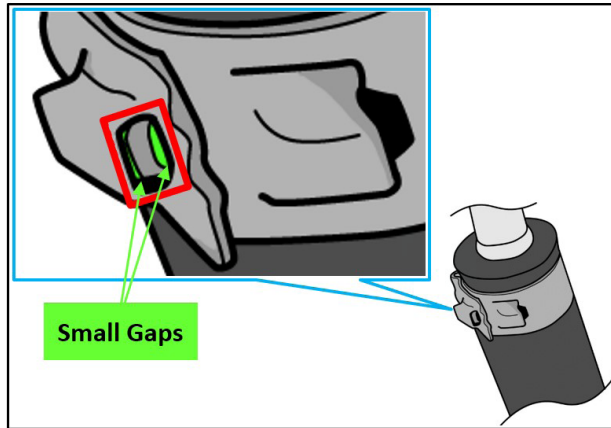

IMPORTANT CAUTIONS:

- If the clamp (805919150) is damaged or broken it **MUST** be replaced with a new part.
- If replacement is required, **ONLY** the upper side of the PCV Vacuum Hose needs to be disconnected. Use caution to not damage any surrounding hoses and/or harnesses.

STEP 7: Install the intake duct and the two mounting fasteners.

CLAIM REIMBURSEMENT AND ENTRY PROCEDURES:

Credit to perform this recall will be based on properly completed repair order information. Retailers may submit claims through Subarunet.com.

Labor Description	Labor Operation #	Labor Time	Fail Code
INSPECTION OF THE PCV VACUUM HOSE CLAMP AND ADJUSTMENT TO A FULLY LOCKED CONDITION	A456-233	0.3	WRB-22

CALIFORNIA “VEHICLE EMISSION RECALL - PROOF OF CORRECTION” CERTIFICATE

The California Air Resources Board and the Department of Motor Vehicles Registration/Recall Program requires that all emission related Recall/Campaign or Service Program repairs be completed before a vehicle registration is renewed. Please provide owners of vehicles registered in the state of California a completed “Vehicle Emission Recall - Proof of Correction” certificate. Vehicle owners should be advised to retain this certificate because the California Department of Motor Vehicles may require they provide proof this service program repair has been completed. Additional certificates are available through normal parts ordering channels using part number MSA6P1301. Quantity 1 = 1 booklet of 50 certificates.

Continued...

Part Number	Applicability	Description	Order Quantity
MSA6P1302	All Models	Campaign Completion Labels (contains one sheet of 20 labels)	1

SUBARU
Campaign Code
WRB-22
COMPLETED
DIST./DEALER NO.
SERIAL NO.
DO NOT REMOVE

IMPORTANT REMINDERS:

- SOA strongly discourages the printing and/or local storage of service information as previously released information and electronic publications may be updated at any time.
- Always check for any open recalls or campaigns anytime a vehicle is in for servicing.
- Always refer to STIS for the latest service information before performing any repairs.