



210 Inverness Center Parkway
Birmingham, AL 35242

Telephone: 205-991-7733
Facsimile: 205-991-9993
www.altec.com

This notice applies to your vehicle. See attached serial number list.

Dear Altec Owner,

Altec Industries, Inc. has developed a product improvement as described in the included Service Information Letter (SIL). According to our records, you own one or more units this applies to.

Refer to the included SIL for the items covered under the Altec warranty policy.

Compare the serial number of your unit to the included list of affected units to verify that your unit is affected. You may also contact Altec at 1-877-GO ALTEC (1-877-462-5832) with your unit's serial number to determine if there are any other outstanding notices.

If you have sold or retired the unit, please call Altec at 1-877-GO ALTEC (1-877-462-5832) to update the records.

We regret this inconvenience; however, we are taking this action in the interest of your safety and continued satisfaction with Altec products.

Thank you for your immediate attention on this important matter.

Service Information Letter

August 16, 2021

Units Affected: AT200A aerial devices built on Ford F450/F550 chassis from 2011 to 2016 with non-steel utility bodies (Verify that your unit serial number is affected by reviewing the attached list in this SIL or by accessing your fleet on connect.altec.com/login)

Mounting Frame Inspection, Units with Non-Steel Bodies

Altec is committed to providing our customers with safe and reliable products from initial delivery throughout the useful life of the unit.

Some customers have reported a crack in the side plate of the mounting frame on some units. Altec has developed a kit to reinforce the mounting frame and prevent cracking in the side plate as well as prevent further damage if cracking has already occurred.

Altec requires that each unit be inspected for cracking in the mounting frame side plate no later than the next periodic maintenance interval. Use Inspection Procedure A beginning on page 2.

Altec requires the kit to be installed within one year of the inspection if the side plate has no cracking or within 90 days of the inspection if the side plate is partially cracked. If the side plate is fully cracked, the unit must be taken out of service until the kit is installed. Call 1-877-GO ALTEC (1-877-462-5832) option 1 to order the Mounting Frame Reinforcement Kit, part number 991333793.

The inspection and repair are covered under the Altec Warranty Policy and can be performed by Altec, the customer, or the customer’s warranty provider. All welds must be applied by a welder having the AWS D1.1 3G qualification for steel. An Altec Mobile Service technician can perform this inspection but is not able to perform this repair. Altec will perform the repair for free at an Altec facility. If the customer or the customer’s warranty provider performs the work, a warranty claim must be submitted to be reimbursed for the cost of the parts and/or labor. Altec will allow up to \$45 for the labor to perform the inspection and up to \$180 for the labor to perform the repair.

Call 1-877-GO ALTEC (1-877-462-5832) option 3 to schedule the work to be done by an Altec Mobile Service technician or option 2 to schedule the work to be done at an Altec facility. Customers are responsible for the travel costs of an Altec Mobile Service technician if the technician performs the inspection at the owner’s location.

Altec Use Only	
Inspection labor	0.5 hr
Repair labor	2.0 hr
Account #	010.0557.43151.000.9086.000
Travel	Not included
NHTSA code	98
Prime fail P/N	970246333
Doc ref	074900774

Altec Use Only			
Parts Kit	Part No.	Qty	Warranty
Mounting frame reinforcement kit	991333793	1	Yes

Inspection Procedure A

Normal mechanic’s hand tools, a flashlight, and a wire brush are required for this inspection. Read and understand all steps of the instructions before beginning the procedure.

1. Position the unit on a level surface. Apply the parking brake and turn off the engine. Remove the key from the ignition and secure it. Chock the wheels. Follow your employer’s vehicle lockout/tagout procedure.
2. Find the mounting frame under the vehicle (refer to Figure 1). The initial area to inspect is the narrow section at the rear portion of the side plate on the street side of the mounting frame. Use a wire brush to remove any paint and rust from this area.

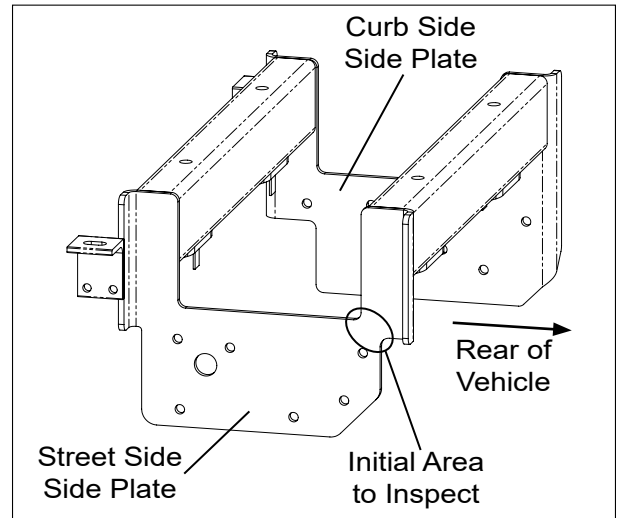

Figure 1 – Mounting Frame Initial Inspection

3. Using a flashlight, inspect the outer surface and the upper and lower rounded corners of the narrow section of the side plate for the extent of any cracking in the steel plate, as defined below.
 - No cracking means no visible cracking at all in the plate.
 - Partial cracking means a visible crack anywhere in the narrow section that extends only part way across the width or part way through the thickness of the plate (refer to Figure 2).
 - Full cracking means a visible crack across the full width of the narrow section extending through the full thickness of the plate and causing the complete separation of the material (refer to Figure 3).

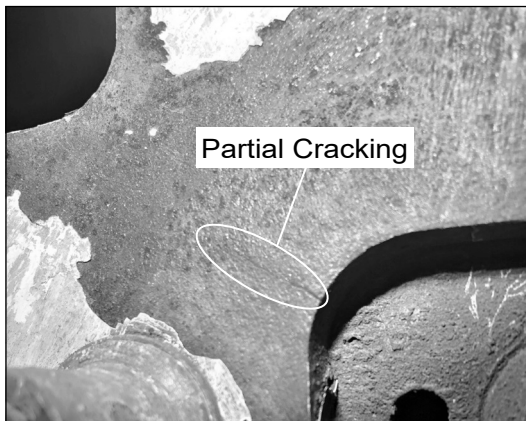

Figure 2 – Partial Cracking Example

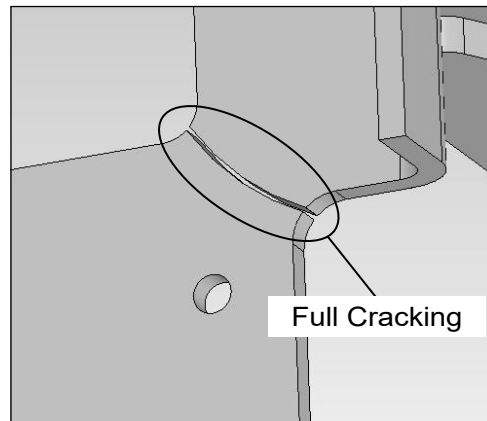

Figure 3 – Full Cracking Example

4. Review the inspection results and take the specified action.

- If there is no cracking, put the unit back into service. Order the kit as specified on page 1 and install it within one year of the inspection. Do not perform Inspection Procedure B.
- If there is partial cracking, put the unit back into service. Order the kit as specified on page 1 and install it within 90 days of the inspection. Do not perform Inspection Procedure B.
- If there is full cracking, take the unit out of service. The vehicle can still be driven but the aerial device cannot be used until it is repaired. Proceed to Inspection Procedure B to determine the necessary repair procedure.

Inspection Procedure B

1. Keep the unit set up as in Inspection Procedure A step 1.

2. Use a wire brush to remove any paint and rust from the other three corners of the mounting frame (refer to Figure 4).

3. Using a flashlight, inspect the outer surface and the rounded corners of the three corners of the mounting frame as shown in Figure 5 for the extent of any cracking in the steel plate.

- If there is no cracking in any of these three areas, order the kit as specified on page 1 and install it before putting the unit back into service.
- If there is cracking in any of these three areas, call 1-877-GO ALTEC (1-877-462-5832) option 1 and speak to Technical Support for further direction.

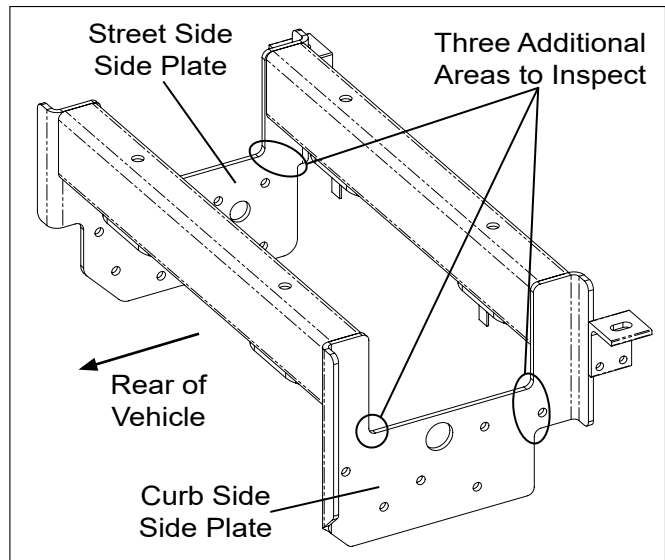

Figure 4 – Mounting Frame Additional Inspection