



David J. Johnson  
 Director  
 Service Engineering Operations  
 Ford Customer Service Division

Ford Motor Company  
 P. O. Box 1904  
 Dearborn, Michigan 48121

May 05, 2021

**TO:** All U.S. Ford and Lincoln Dealers

**SUBJECT: NEW VEHICLE DEMONSTRATION / DELIVERY HOLD  
 Customer Satisfaction Program 21B03 - Supplement #3**  
 Certain 2020 Model Year Super Duty F250-F600 Vehicles Equipped with a 10R140  
 Transmission - Number One Planetary and Ring Gear Assembly

**REF: NEW VEHICLE DEMONSTRATION / DELIVERY HOLD  
 Customer Satisfaction Program 21B03 - Supplement #2**  
 Dated: April 15, 2021

**New! REASON FOR THIS SUPPLEMENT**

- *Parts Requirements / Ordering Information: All parts are now on open order.*
- *Technical Information: Update for program specific transmission fluid filter requirements.*

**PROGRAM TERMS**

This program will be in effect through March 31, 2022. There is no mileage limit for this program. Eligible vehicles, with 6.7L diesel engines, in this program include the following:

- Emergency vehicles and wrecker vehicles.
- Vehicles with a 4.88 axle gear ratio.
- Vehicles with a 4.30 axle gear ratio.
- Vehicles with a 4.10 axle gear ratio.

**EXPIRATION DATE**

This Customer Satisfaction Program has an expiration date of March 31, 2022 to encourage dealers and customers to have this service performed as soon as possible.

We recommend dealers utilize their FSA VIN Lists name and address (available on April 02, 2021 to contact customers with affected vehicles. This will help minimize the number of vehicles that may experience a higher-level of service repair.

**AFFECTED VEHICLES**

**Note:** This program is only applicable to vehicles with 6.7L diesel engines.

Vehicle	Model Year	Assembly Plant	Build Dates
Super Duty F250-F600	2020	Kentucky Truck	28-Feb-2019 through 10-Aug-2020
		Ohio Assembly	03-Apr-2019 through 31-Jul-2020

Affected vehicles are identified in OASIS and FSA VIN Lists.

## **REASON FOR THIS PROGRAM**

In all of the affected vehicles, a distressed No. 1 planetary needle bearing inside the ring gear assembly will generate contamination that may produce rough shifts. A wrench light is likely to come on, and the transmission may go into safe mode and only operate in seventh gear. As damage progresses, the transmission may only be capable of limited vehicle speed or may not engage in forward or reverse.

## **SERVICE ACTION**

Dealers are to replace the No. 1 planetary and ring gear assembly per the Technical Information given in Attachment III. This service must be performed on all affected vehicles at no charge to the vehicle owner.

## **New! OWNER NOTIFICATION MAILING SCHEDULE**

*Parts to repair this condition are now available in sufficient quantities to service all of the affected vehicles. All VINs have been activated. All owner notification through Supplement #2 is complete as of the end of April 2021.* Dealers should repair any affected vehicles that arrive at their dealerships, whether or not the customer has received a letter.

## **New! ATTACHMENTS**

Attachment I: Administrative Information  
*Attachment II:* Labor Allowances and *Parts Ordering Information*  
*Attachment III:* *Technical Information*  
Owner Notification Letter

## **QUESTIONS & ASSISTANCE**

For questions and assistance, contact the Special Service Support Center (SSSC) via the SSSC Web Contact Site. The SSSC Web Contact Site can be accessed through the Professional Technician System (PTS) website using the SSSC link listed at the bottom of the OASIS VIN report screen or listed under the SSSC tab.

Sincerely,



David J. Johnson

**NEW VEHICLE DEMONSTRATION / DELIVERY HOLD  
Customer Satisfaction Program 21B03 - *Supplement #3***

Certain 2020 Model Year Super Duty F250-F600 Vehicles Equipped with a 10R140 Transmission  
Number One Planetary and Ring Gear Assembly

**OASIS ACTIVATION**

OASIS was activated on March 2, 2021.

**FSA VIN LISTS ACTIVATION**

FSA VIN Lists were available through <https://web.fsavinlists.dealerconnection.com> starting on March 2, 2021. Owner names and addresses will be available by April 02, 2021 for emergency vehicles and wrecker vehicles. Owner names and addresses will be available by April 23, 2021 for the supplement #1 population of 4.88 axle gear ratio vehicles. Owner names and addresses will be available by May 14, 2021 for the supplement #2 population of 4.88 axle gear ratio vehicles.

**NOTE:** Your FSA VIN Lists may contain owner names and addresses obtained from motor vehicle registration records. The use of such motor vehicle registration data for any purpose other than in connection with this program is a violation of law in several states, provinces, and countries. Accordingly, you must limit the use of this listing to the follow-up necessary to complete this service action.

**SOLD VEHICLES**

- Owners of affected vehicles will be directed to dealers for repairs.
- Immediately contact any of your affected customers whose vehicles are not on your VIN list but are identified in OASIS. Give the customer a copy of the Owner Notification Letter (when available) and schedule a service date.
- Correct other affected vehicles identified in OASIS which are brought to your dealership.
- Dealers are to prioritize repairs of customer vehicles over repairs of new and used vehicle inventory.

**STOCK VEHICLES**

- Correct all affected units in your new vehicle inventory before delivery.
- Use OASIS to identify any affected vehicles in your used vehicle inventory.

**TITLE BRANDED / SALVAGED VEHICLES**

Affected title branded and salvaged vehicles are eligible for this service action.

**OWNER REFUNDS**

- Ford Motor Company is offering a refund for owner-paid repairs covered by this program if the repair was performed before the date of the Owner Notification Letter. This refund offer expires **October 30, 2021**.
- Dealers are also pre-approved to refund owner-paid emergency repairs that were performed away from an authorized servicing dealer after the date of the Owner Notification Letter. Non-covered repairs, or those judged by Ford to be excessive, will not be reimbursed.
- Refunds will only be provided for the cost associated with planetary one needle bearing assembly.

**NEW VEHICLE DEMONSTRATION / DELIVERY HOLD  
Customer Satisfaction Program 21B03 - Supplement #3**

Certain 2020 Model Year Super Duty F250-F600 Vehicles Equipped with a 10R140 Transmission  
Number One Planetary and Ring Gear Assembly

**RENTAL VEHICLES**

Dealers are pre-approved for non-commercial and non-fleet vehicles for up to two days for a rental vehicle. Follow Extended Service Plan (ESP) guidelines for dollar amounts. Rentals will only be reimbursed for the day(s) the vehicle is at the dealership for part replacement. Prior approval for more than two rental days is required from the SSSC via the SSSC Web Contact Site.

**ADDITIONAL REPAIR (LABOR TIME AND/OR PARTS)**

Additional repairs identified as necessary to complete the FSA should be managed as follows:

- For related damage and access time requirements, refer to the Warranty and Policy Manual / Section 6 – Ford & Lincoln Program Policies / General Information & Special Circumstances for FSA's / Related Damage.
- For vehicles within new vehicle powertrain warranty coverage, no SSSC approval is required, although related damage must be on a separate repair line with the "Related Damage" radio button checked.
  - Ford vehicles – 5 years or 60,000 miles
- For vehicles outside new vehicle powertrain warranty coverage, submit an Approval Request to the SSSC Web Contact Site prior to completing the repair.

**CLAIMS PREPARATION AND SUBMISSION**

- **Claim Entry:** Enter claims using Dealer Management System (DMS) or One Warranty Solution (OWS) online.

Description When Entering Claims	Enter Value:
Select claim type 31	Field Service Action
Sub Code	21B03
Causal Part Number	7L192
Customer Concern Code (CCC)	P59 – AT Other Transmission Troubles
Condition Code (CC)	42 – Does Not Operate Properly

- For additional claims preparation and submission information, refer to the Recall and Customer Satisfaction Program (CSP) Repairs in the OWS User Guide.
- **Related Damage/Additional labor and/or parts:** Must be claimed as Related Damage on a separate repair line from the FSA with same claim type and sub code as described in Claim Entry above.  
**IMPORTANT:** Click the Related Damage Indicator radio button.
- **Provision for Locally Obtained Supply:** Includes petroleum jelly and the following Motorcraft chemicals - XL-1 Penetrating and Lock Lubricant, XL-2 High Temp Nickel Anti-Seize Lubricant, XL-5-A Multi-Purpose Grease Spray, X0-5W20-Q1FS SAE Full Synthetic Motor Oil.
  - Program Code: **21B03**
  - Misc Expense: OTHER
  - Amount: Actual cost up to \$5.00

**NEW VEHICLE DEMONSTRATION / DELIVERY HOLD  
Customer Satisfaction Program 21B03 - *Supplement #3***

Certain 2020 Model Year Super Duty F250-F600 Vehicles Equipped with a 10R140 Transmission  
Number One Planetary and Ring Gear Assembly

**CLAIMS PREPARATION AND SUBMISSION (continued)**

- **Rentals:** For rental vehicle claiming, follow Extended Service Plan (ESP) guidelines for dollar amounts. Enter the total amount of the rental expense under Miscellaneous Expense code RENTAL.
- **Refunds:** Submit refunds on a separate repair line.
  - Program Code: 21B03                      - Misc. Expense: ADMIN
  - Misc. Expense: REFUND                      - Misc. Expense: 0.2 Hrs.
- Multiple refunds should be submitted on one repair line and the invoice details for each repair should be detailed in the comments section of the claim.

**NEW VEHICLE DEMONSTRATION / DELIVERY HOLD  
Customer Satisfaction Program 21B03 - *Supplement #3***

Certain 2020 Model Year Super Duty F250-F600 Vehicles Equipped with a 10R140 Transmission  
Number One Planetary and Ring Gear Assembly

**LABOR ALLOWANCES**

Description	Labor Operation	Labor Time
Replace the No. 1 Planetary and Ring Gear Assembly – 4x4 Vehicles	MT21B03B	Up To 10.2 Hours
Replace the No. 1 Planetary and Ring Gear Assembly – 4x2 Vehicles	MT21B03C	Up To 9 Hours

**New! PARTS REQUIREMENTS / ORDERING INFORMATION**

*Order the parts below through normal order processing channels:*

Part Number	Description – All Vehicles	Order Quantity	Claim Quantity
LC3Z-7L192-B	No. 1 Planetary and Ring Gear Assembly	1	1
LC3Z-7G186-A	Fluid Filter - Screen Assembly – <i>Refer to Updated Technical Information in Attachment III</i>	As Needed	1
LC3Z-7A248-A	Seal - Torque Converter Hub	1	1
LC3Z-7B031-B	Seal - Front Support to Case	1	1
LC3Z-7H223-A	Seals - Front Support Bolt	16	16
W520515-S440	Nuts - Crossmember Bracket (4 per pkg, 4 req'd)	1	4
W710356-S439	Bolts - Crossmember Bracket (4 per pkg, 4 req'd)	1	4
W714824-S442	Bolts - Selector Lever Cable Bracket (4 per pkg, 2 req'd)	1	2
W715131-S442	Bolt - Fluid Cooler Tube (4 per pkg, 1 req'd)	1	1
W715618-S437	Nuts - Torque Converter (4 per pkg, 6 req'd)	2	6
W718005-S900	Bolts - Exhaust Lower Downpipe (2 per pkg, 2 req'd)	1	2
W520514-S440	Y-pipe to exhaust manifold nuts	4	4
XT-10-QLVC	Motorcraft® MERCON® LV Automatic Transmission Fluid for Transfer Case (12 Qt. per pkg, 1 req'd)	1	Up to 1 Quart
XT-12-QULV	Motorcraft® MERCON® ULV Automatic Transmission Fluid	16	16

**NEW VEHICLE DEMONSTRATION / DELIVERY HOLD  
Customer Satisfaction Program 21B03 - Supplement #3**

Certain 2020 Model Year Super Duty F250-F600 Vehicles Equipped with a 10R140 Transmission  
Planetary One and Ring Gear Assembly

**PARTS REQUIREMENTS / ORDERING INFORMATION (continued)**

**Order the parts below through normal order processing channels:**

Part Number	Description – <u>4X4</u> Vehicles Only	Order Quantity	Claim Quantity
391558-S102	4X4 - Bolts - Transmission Mount Isolator	2	2
E4HZ-4A254-B	4X4 - Strap - Front Driveshaft Pinion Flange Strap	2	2
F81Z-4N272-AA	4X4 - Bolts - Front Driveshaft Pinion Flange (4 per pkg, 4 req'd)	1	4
N605804-S439	4X4 - Bolts – Transfer Case to Transmission (4 per pkg, 11 req'd)	3	11
N811880-S100	4X4 - Bolts - Front Driveshaft CV Flange (4 per pkg, 4 req'd)	1	4

Part Number	Description – Unique Per Vehicle	Order Quantity	Claim Quantity
E4HZ-4A254-A	Strap - Rear Driveshaft - Strap Style to U-Joint Only	As Needed	4
F1HZ-4N272-A	Bolts - Rear Driveshaft - Strap Style to U-Joint Only	Needed	8
N811880-S100	Bolts - Rear Driveshaft Pinion Flange - Flange Style (Note Same Part # as 4X4 CV Flange Bolts) (4 per pkg, 8 req'd, Order 2 as Needed)	As Needed	8
BC3Z-4N272-A	Bolts - Rear Driveshaft - for Center Bearing Only	As Needed	2
W709771-S440	4X2 - Nuts - Transmission Mount Isolator	As Needed	2

Part Number	Description – All Vehicles	Order Quantity	Claim Quantity
XL-1	Motorcraft® Penetrating and Lock Lubricant	Claim as Misc. Other Up to \$5 Total	
XL-2	Motorcraft® High Temp Nickel Anti-Sieze Lubricant		
XL-5-A	Motorcraft® Multi-Purpose Grease Spray		
XO-5W20-Q1FS	Motorcraft® SAE 5W-20 Full Synthetic – for Wheel Hub		
Obtain Locally	Petroleum Jelly		

To guarantee the shortest delivery time, an emergency order for parts must be placed.

**NEW VEHICLE DEMONSTRATION / DELIVERY HOLD  
Customer Satisfaction Program 21B03 - *Supplement #3***

Certain 2020 Model Year Super Duty F250-F600 Vehicles Equipped with a 10R140 Transmission  
Planetary One and Ring Gear Assembly

**PARTS REQUIREMENTS / ORDERING INFORMATION (continued)**

**DEALER PRICE**

For latest prices, refer to DOES II.

**PARTS RETENTION, RETURN, & SCRAPPING**

Follow the provisions of the Warranty and Policy Manual, Section 1 - WARRANTY PARTS RETENTION AND RETURN POLICIES. If a replaced part receives a scrap disposition, the part must be scrapped in accordance with all applicable local, state and federal environmental protection and hazardous material regulations. Federal law prohibits selling motor vehicle parts or components that are under safety, compliance, or emissions recall.

**EXCESS STOCK RETURN**

Excess stock returned for credit must have been purchased from Ford Customer Service Division in accordance with Policy Procedure Bulletin 4000.

**REPLACED FSA PARTS INSPECTION AND SIGN OFF**

Effective March 1<sup>st</sup> 2021 all parts replaced as part of an FSA repair with a repair order open date of March 1<sup>st</sup> 2021 or later must be inspected and signed off on the repair order by a member of your dealers fixed operations management team or an employee the task has been delegated to. If the task is to be delegated to a non-management employee, the employee needs to be someone other than the technician who completed the repair and needs to understand the importance of completing this task consistently and accurately.

- All parts replaced as part of an FSA repair should be returned to the parts department following the Warranty Parts Retention and Return Policies.
- Inspect the replaced parts to verify the FSA repair was completed.
- If the FSA repair is found to be complete, the designated employee signs the repair order line or parts return stamp area (electronic or hand signed) for the FSA repair indicating the parts were inspected and validated to have been replaced.
- After the parts have been inspected, they should be handled based on the guidance in the parts status report in the Online Warranty System (Hold, Return, CORE, Scrap, etc.).
- This process is subject to review during warranty audits for FSA repairs with a repair order open date of March 1<sup>st</sup> 2021 or later. Any eligible FSA claims requiring parts replacement, found not to have been inspected and signed off during a warranty audit will be subject to chargeback and consideration for enrollment into the Dealer Incomplete Recall Repair Process.

**Note:** Other approvals (electronic or handwritten) for add-on repair lines, dealer owned vehicle repairs, and repeat repairs do not qualify as FSA parts inspection approvals. The post repair FSA parts inspection process (electronic or handwritten) is independent from other warranty approval requirements. The approval by the designated employee implies that the FSA parts were found to be replaced and must be able to be clearly identified on the Repair Order. If multiple FSA's require approval on a single Repair Order, each applicable occurrence will require individual post repair approval by the designated employee.



## CERTAIN 2020 MODEL YEAR SUPER DUTY F250-F600 VEHICLES EQUIPPED WITH A 10R140 TRANSMISSION — NUMBER ONE PLANETARY AND RING GEAR ASSEMBLY

### **NEW!** SERVICE PROCEDURE

#### Unique Tools

205-1018 Installation Tube
307-309 Remover, Torque Converter Seal
307-346 Retainer, Torque Converter
307-651 Bracket, Pump Remover/Installer
307-741 Spring Compressor, F Clutch
307-741-01 Remover, Front Support and Cover
307-797 Installer, Alignment Studs (3) and Alignment Pin (All 10R)
307-807 Installer Converter Seal
307-798 Remover/Installer One Way Clutch
307-811 Pusher and sizer, F2 Seal Guide
307-809 Pusher and sizer, F0 Seal Guide
307-810 Pusher and sizer, F9 Seal Guide

1. Remove the transmission from the vehicle. Please follow the Workshop Manual (WSM) procedures in Section 307-01B.

**NOTE:** Special instructions *for the transmission fluid filter*.

- For all **UNSOLD**/in-stock vehicles: reinstall and reuse the transmission fluid filter from the vehicle.
- For all **SOLD** vehicles - *Replace the transmission fluid filter*.



2. Place the transmission on a mounting stand. See Figure 1.

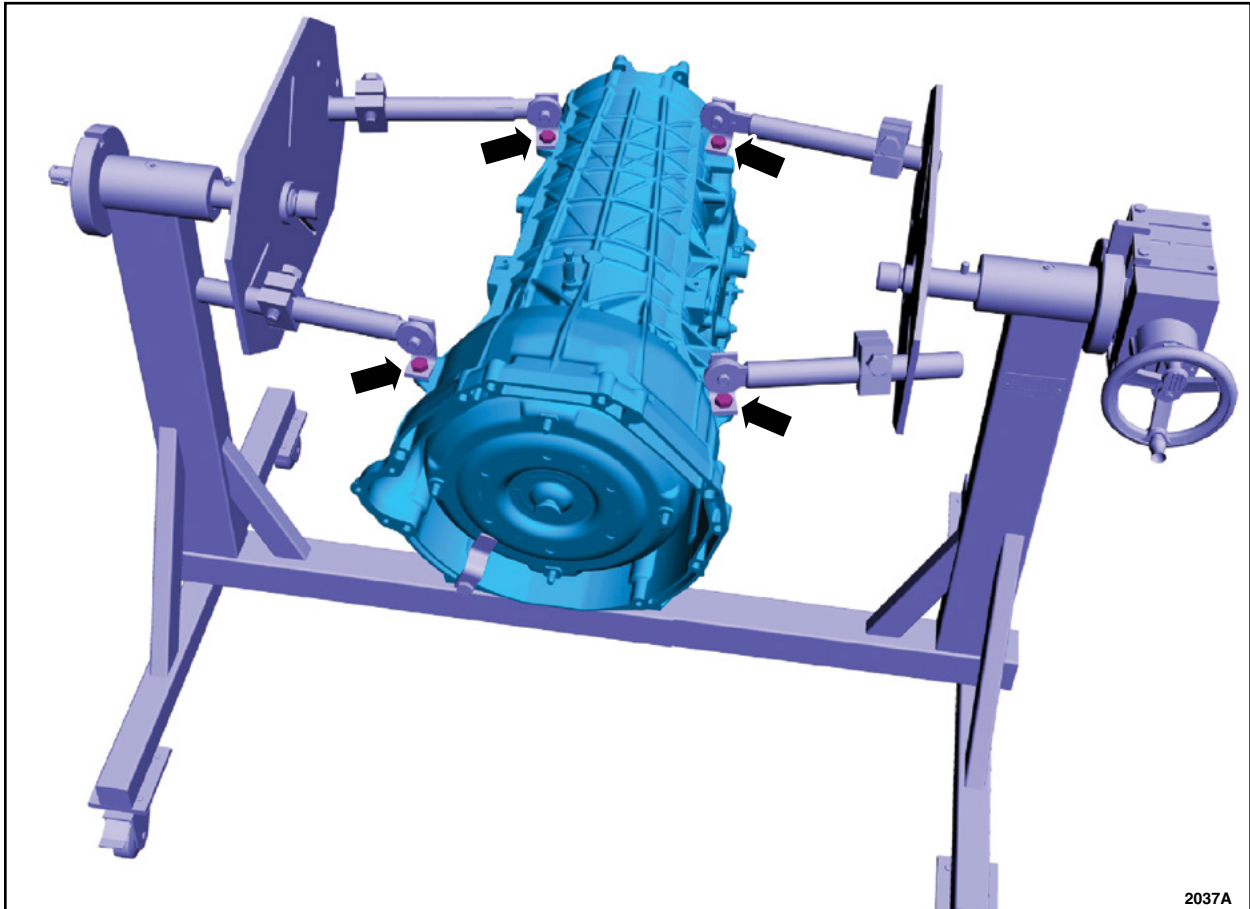
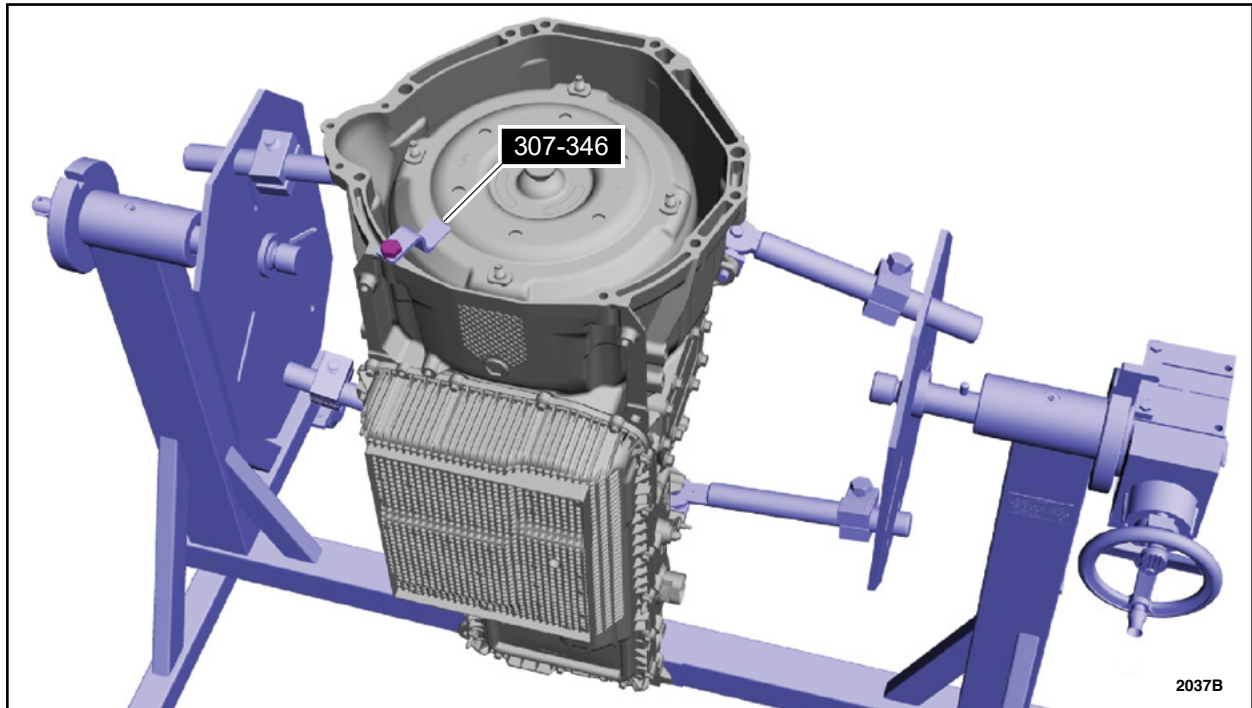

FIGURE 1



3. Rotate the transmission in a vertical position, then remove the special service tool 307-346.  
See Figure 2.



**FIGURE 2**



4. Using special service tool 307-651 and a floor crane, remove the torque converter. See Figure 3.

1. Horizontal pin is in the bottom hole.
2. Vertical pin prevents part movement.

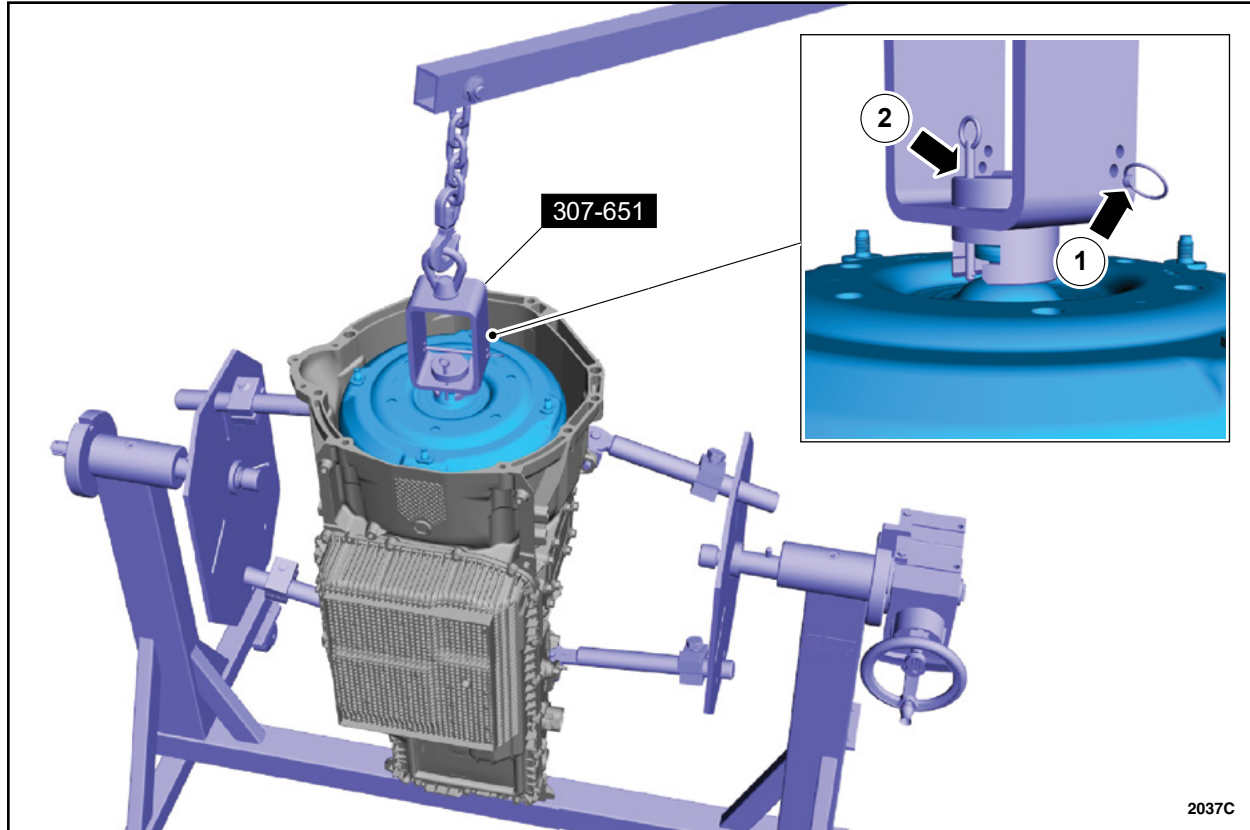
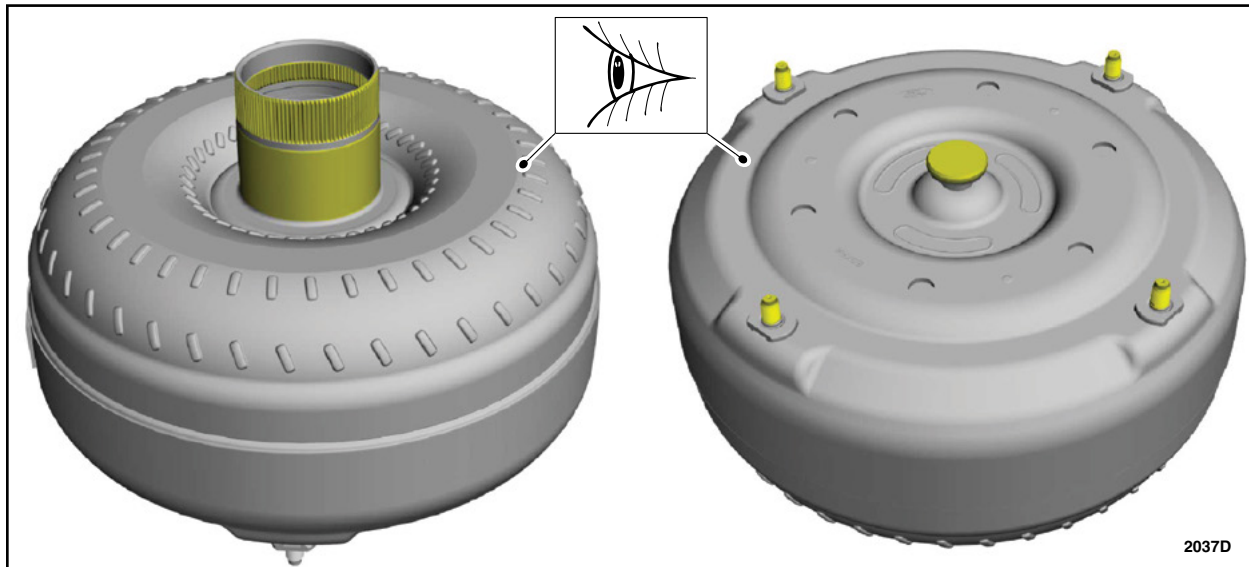

FIGURE 3



5. Inspect the torque converter. If you answer yes to any of the following questions a new or re-manufactured torque converter must be installed. See Figure 4.

- Does the sealing surface have a groove worn from the seal?
- Has a torque converter malfunction been determined based on complete diagnostic procedures?
- Is the torque converter stud or studs, threaded pads, impeller hub or bushing damaged?
- Is there evidence of water or antifreeze contamination?
- Does the torque converter exhibit external discoloration (due to overheating)?
  - Overheat discoloration would be a darker color with possible bluing.
  - Discoloration would be a different color than the rest of the torque converter.



**FIGURE 4**

6. Remove the main control valve body. Please follow the WSM procedures in Section 307-01B.

7. Remove the intermediate sensor A. Please follow the WSM procedures in Section 307-01B.



**NOTE:** Use a 10ep Torx Plus® socket for the transmission fluid pump bolts.

8. Remove the bolts and the transmission fluid pump. See Figure 5.

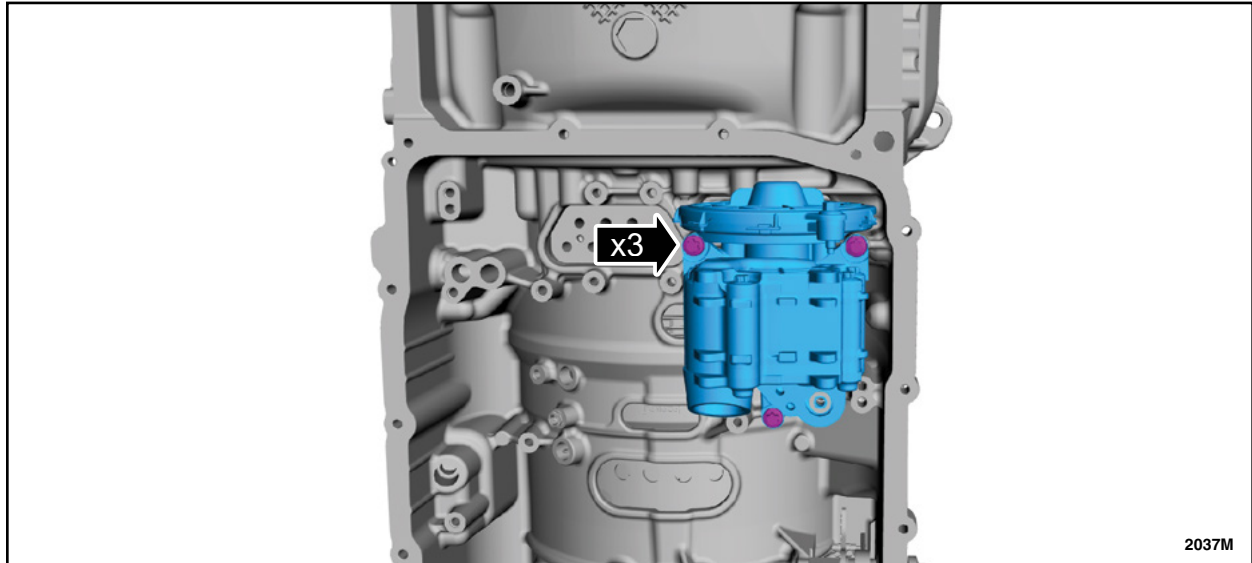

**FIGURE 5**

9. Remove the transmission fluid pump seal. See Figure 6.



**FIGURE 6**



10. Remove the front support assembly bolts. See Figure 7.

- Discard the front support assembly bolt washers.

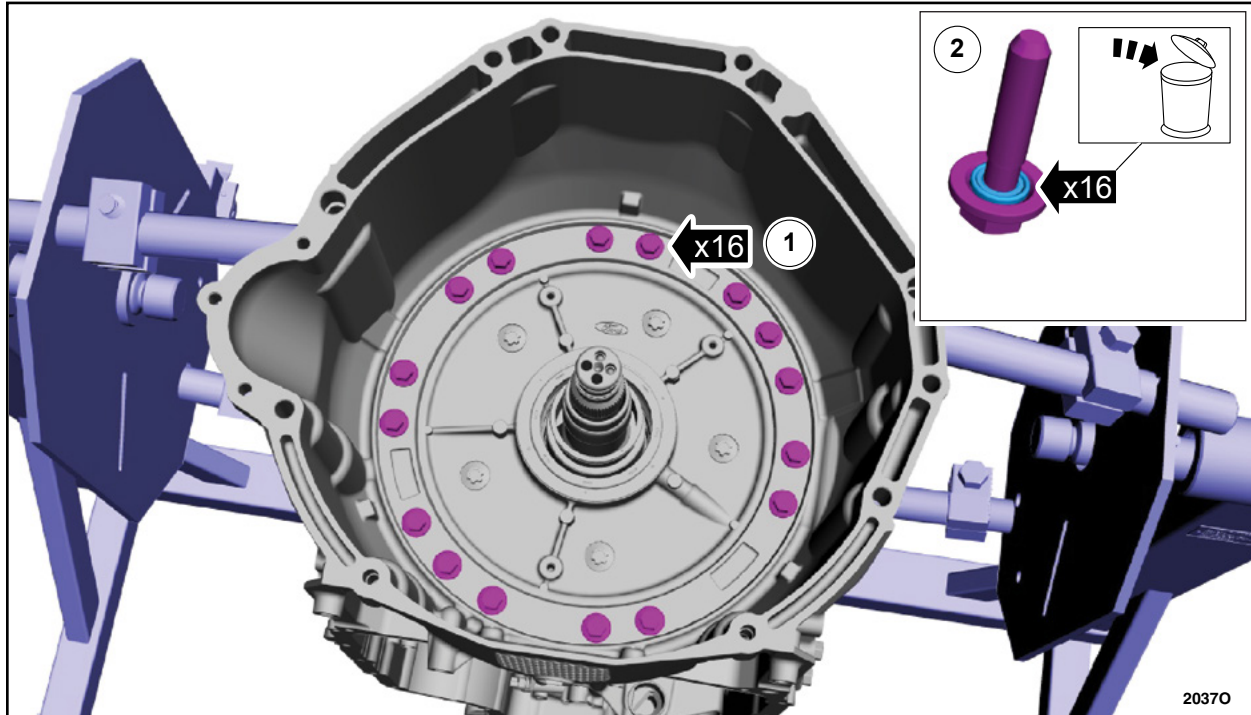

FIGURE 7





11. Using special tool 307-741 and 307-741-01, separate the front support assembly from the transmission case and remove the final support assembly. Remove special tools 307-741 and 307-741-01. See Figure 8.

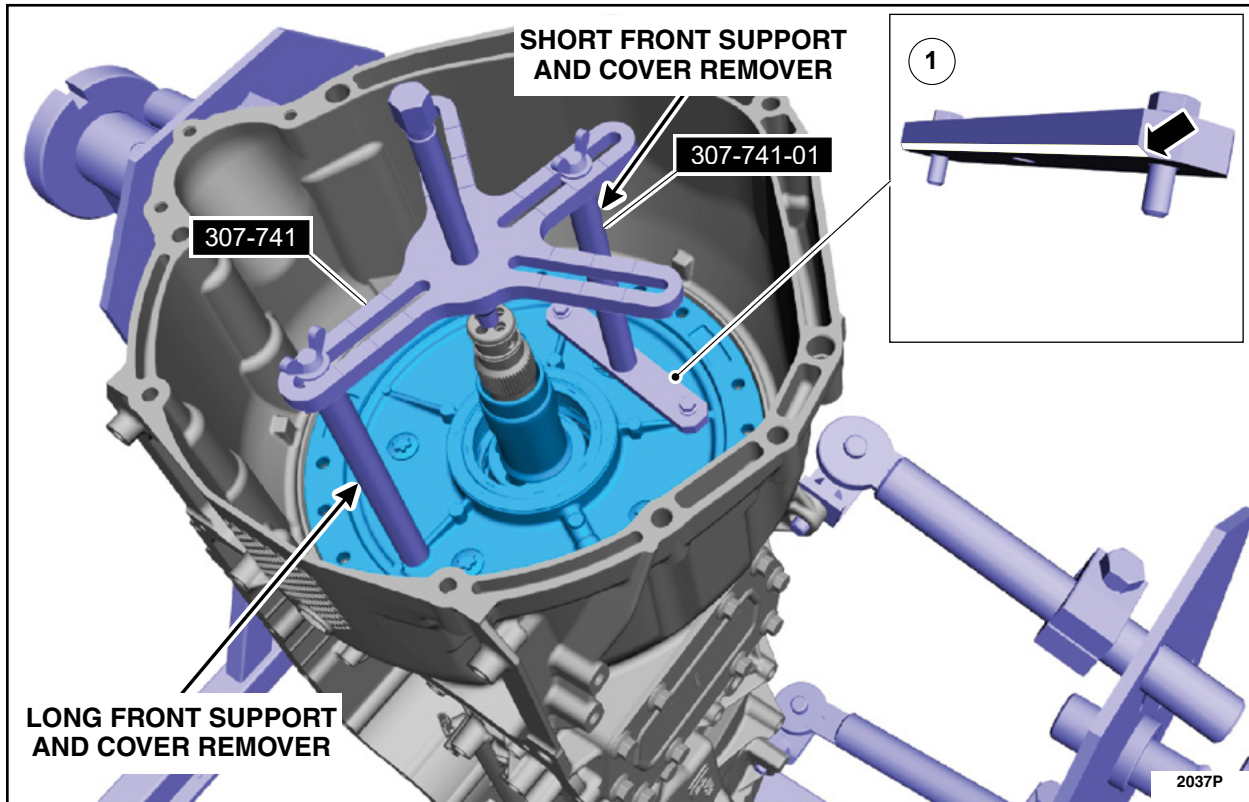

FIGURE 8

12. Remove and discard the front support-to-case seal. See Figure 9.

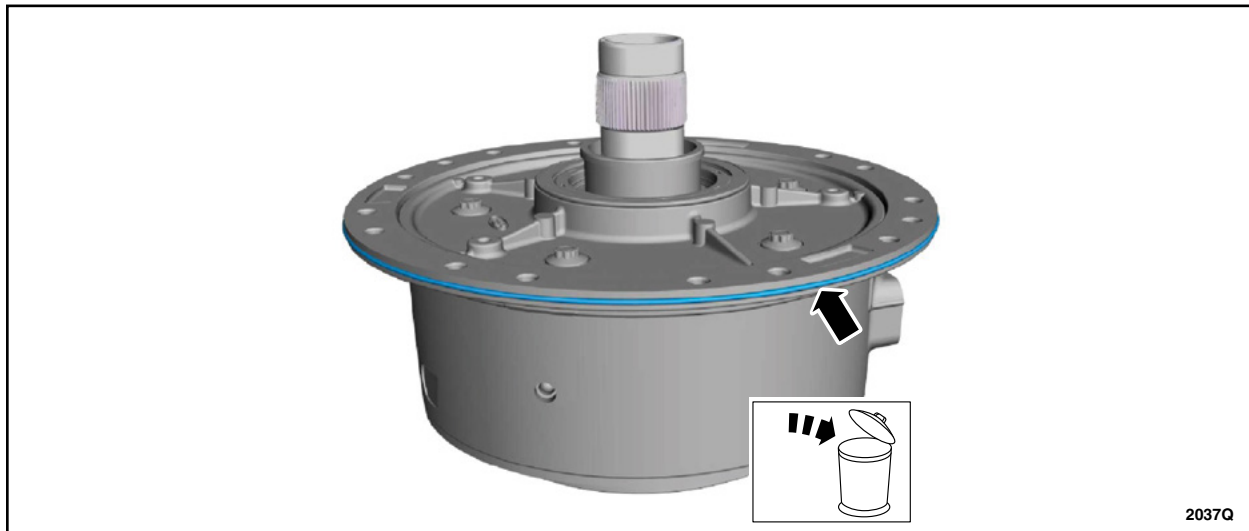

FIGURE 9





13. Using special tools 307-309, 307-741-01 and 307-798, remove and discard the converter hub seal.  
See Figure 10.

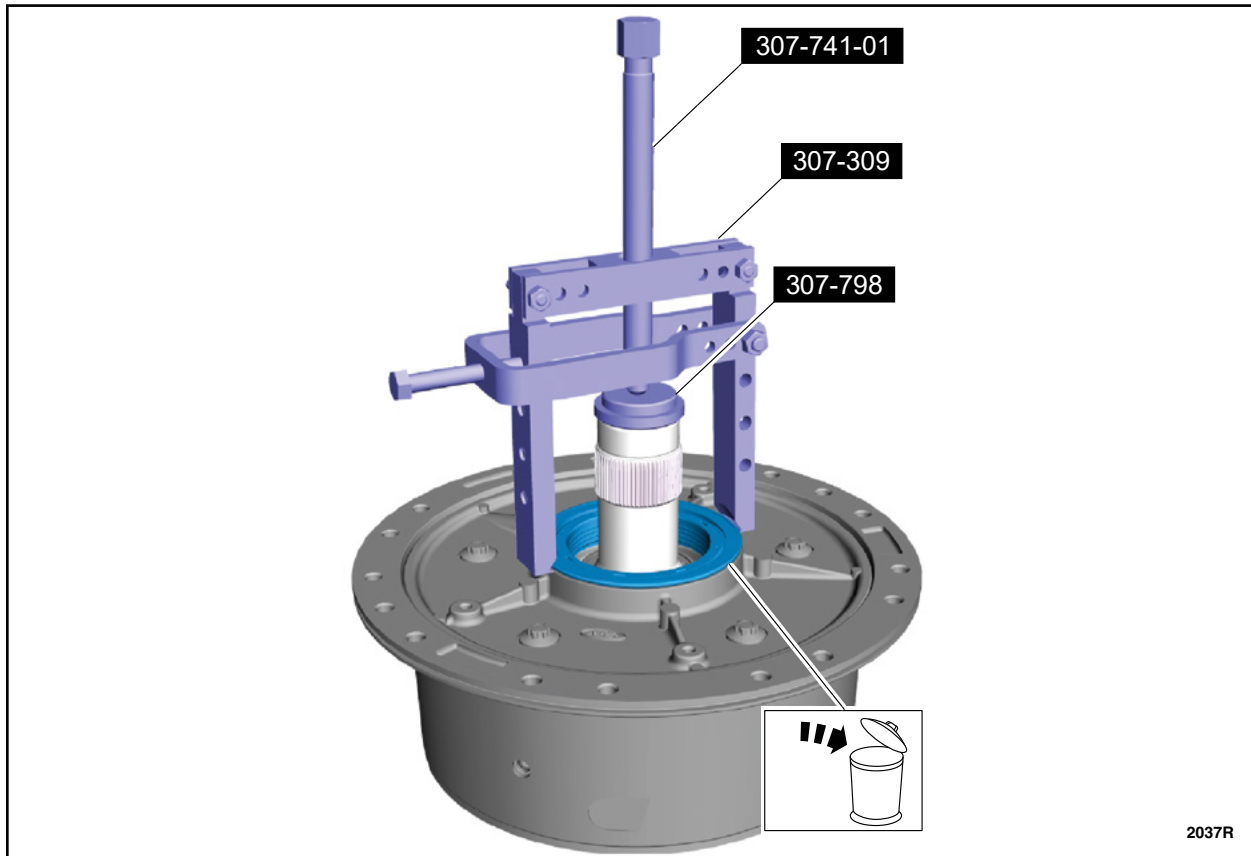

FIGURE 10



14. Using a magnet, remove the A clutch assembly. See Figure 11.

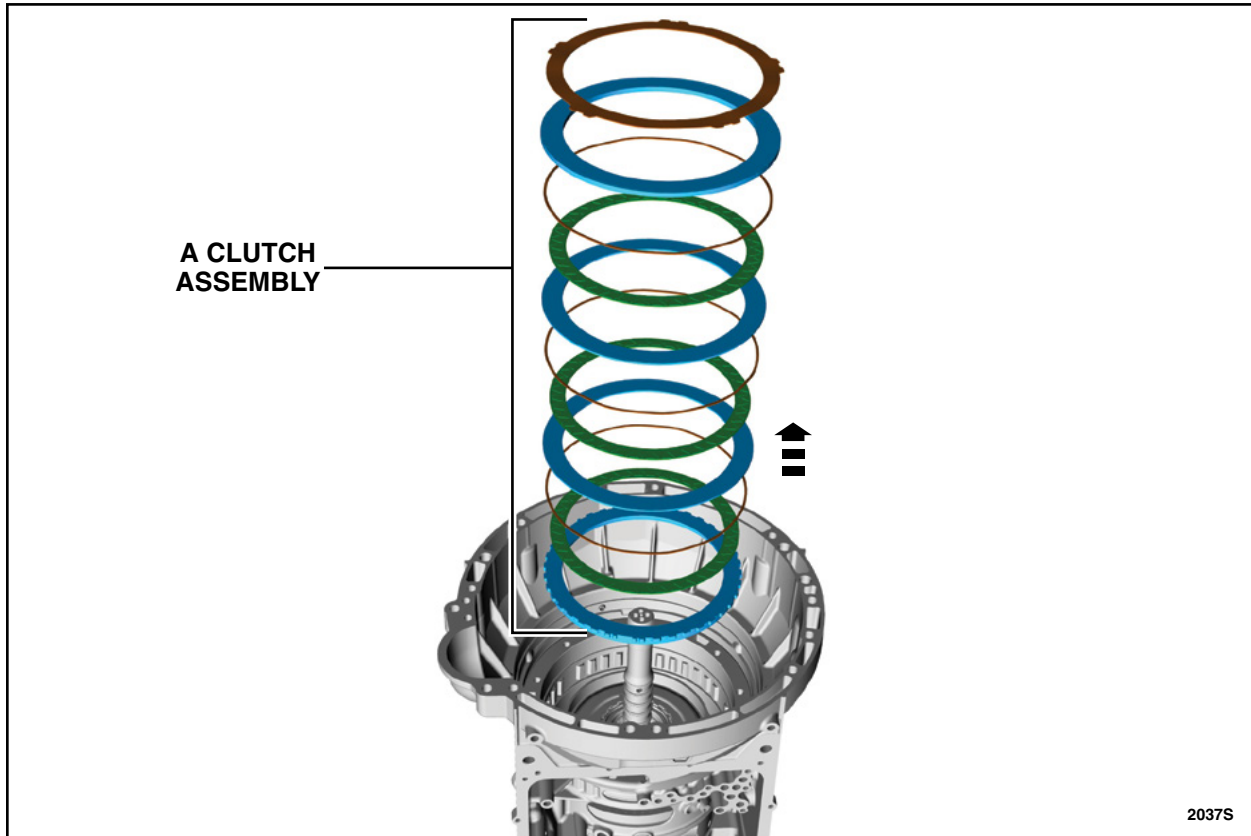

FIGURE 11



15. Using a pick, remove the number one planetary carrier snap ring. See Figure 12.

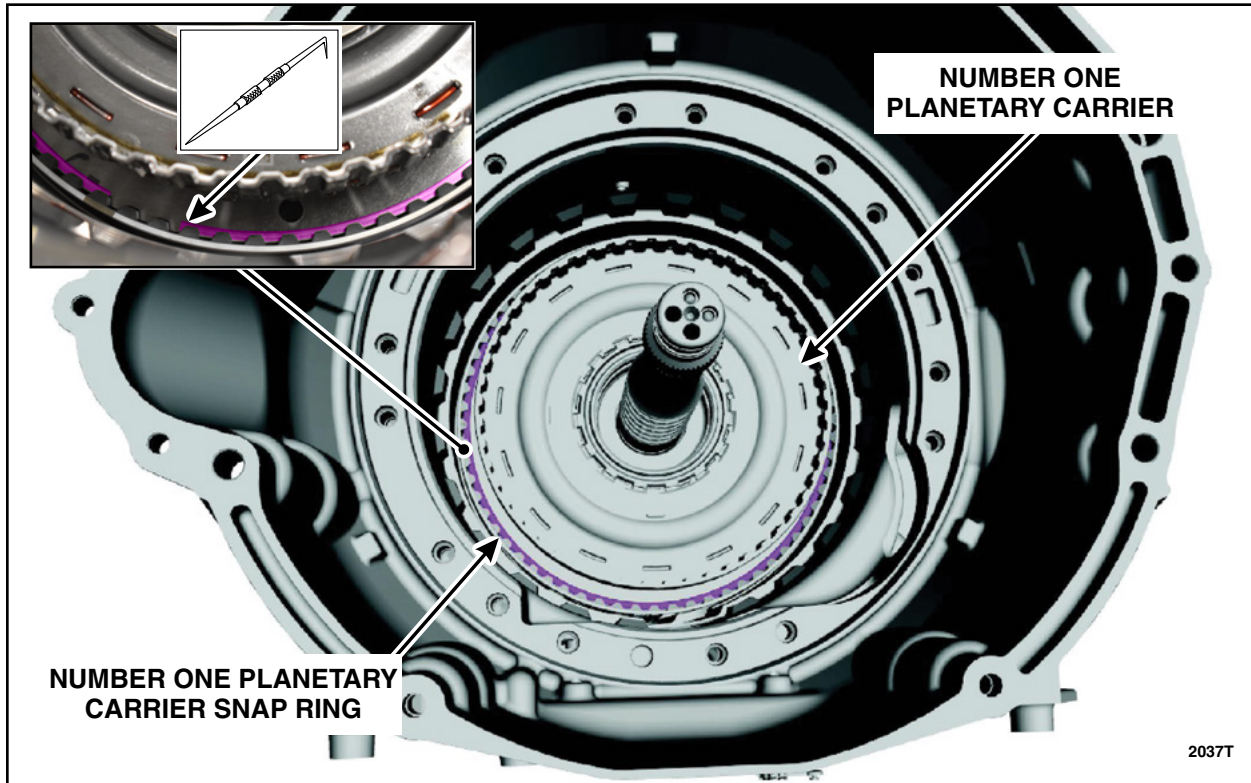

FIGURE 12

16. Using two pick hooks inserted into holes on the outside gear, remove and discard the number one planetary carrier. See Figure 13.

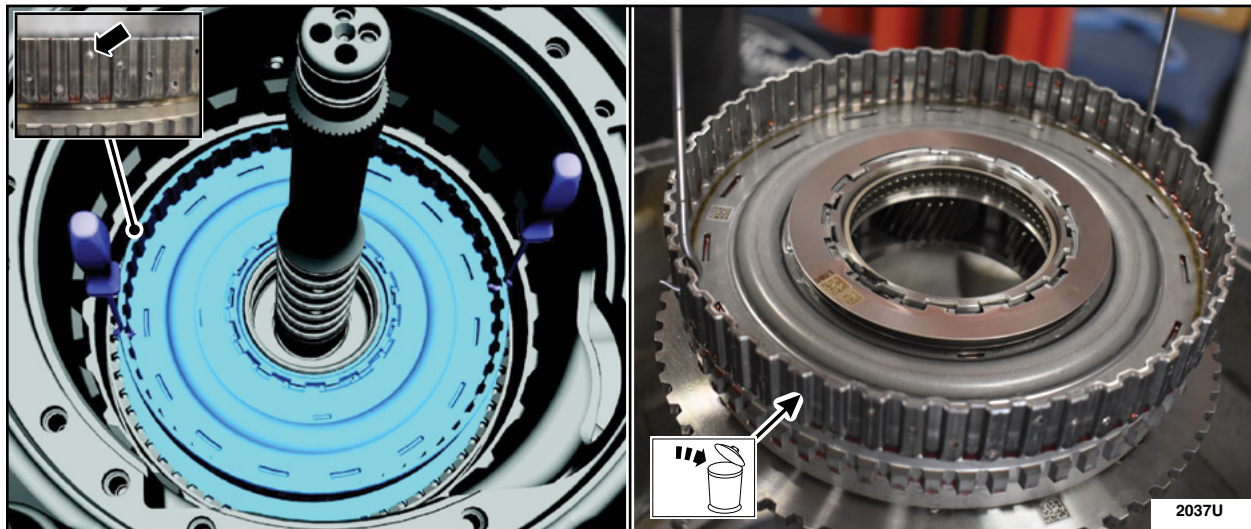
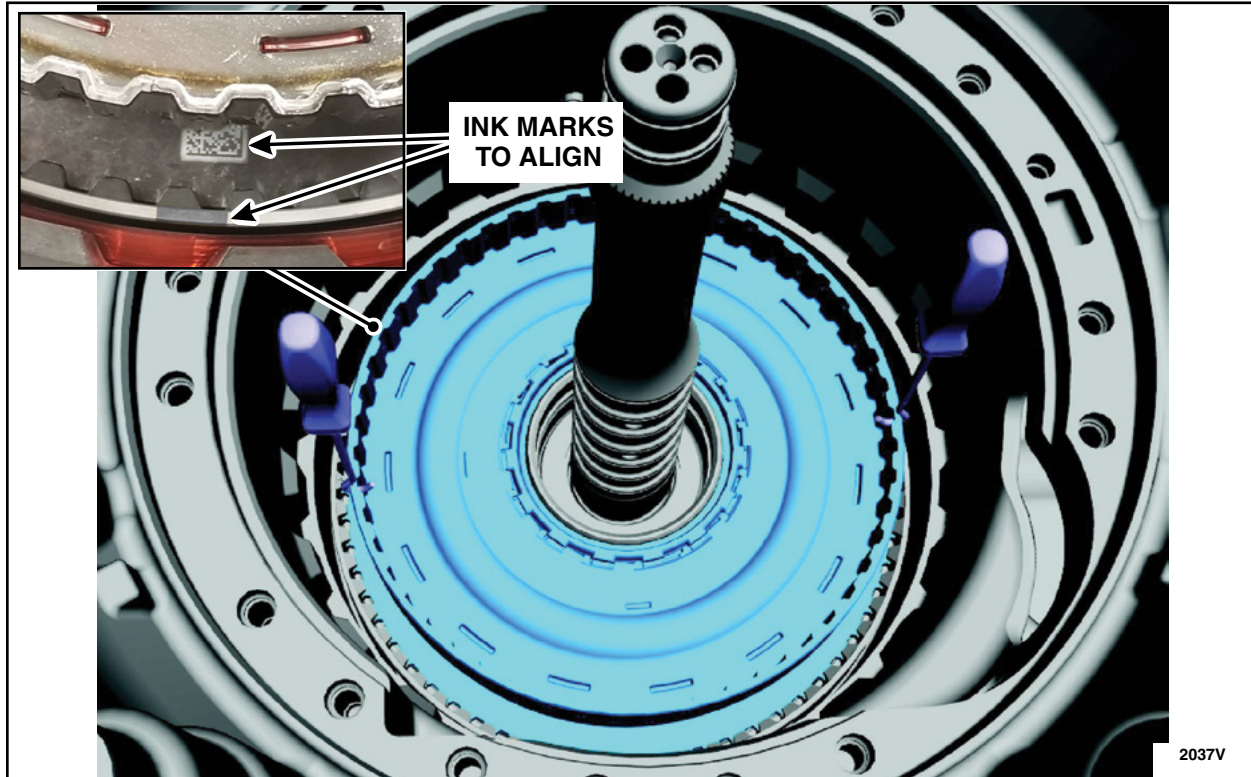

FIGURE 13



**NOTE:** The ink marks must be aligned or a transmission vibration can occur.

17. Using two pick hooks, install the new number one planetary carrier with the ink markings aligned.  
See Figure 14.



**FIGURE 14**





18. Using a long flat head screwdriver, install the number one planetary carrier snap ring. Be sure that the snap ring is fully seated. See Figure 15.

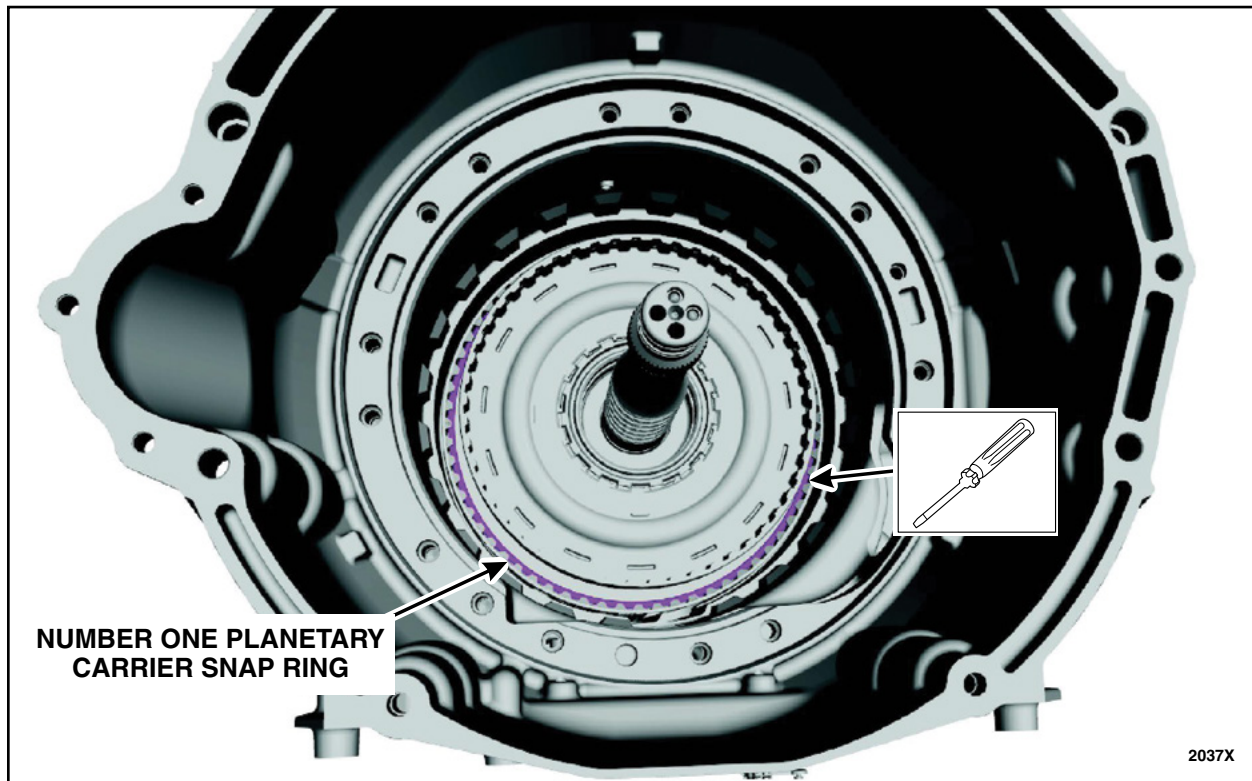

FIGURE 15



19. Soak the A clutch plates in clean transmission fluid and then install the A clutch assembly.  
See Figure 16.

1. Pressure Plate.
2. Friction Plates.
3. Separator Springs.
4. Steel Plates.
5. Apply Plate (select fit).
6. Wave Spring.

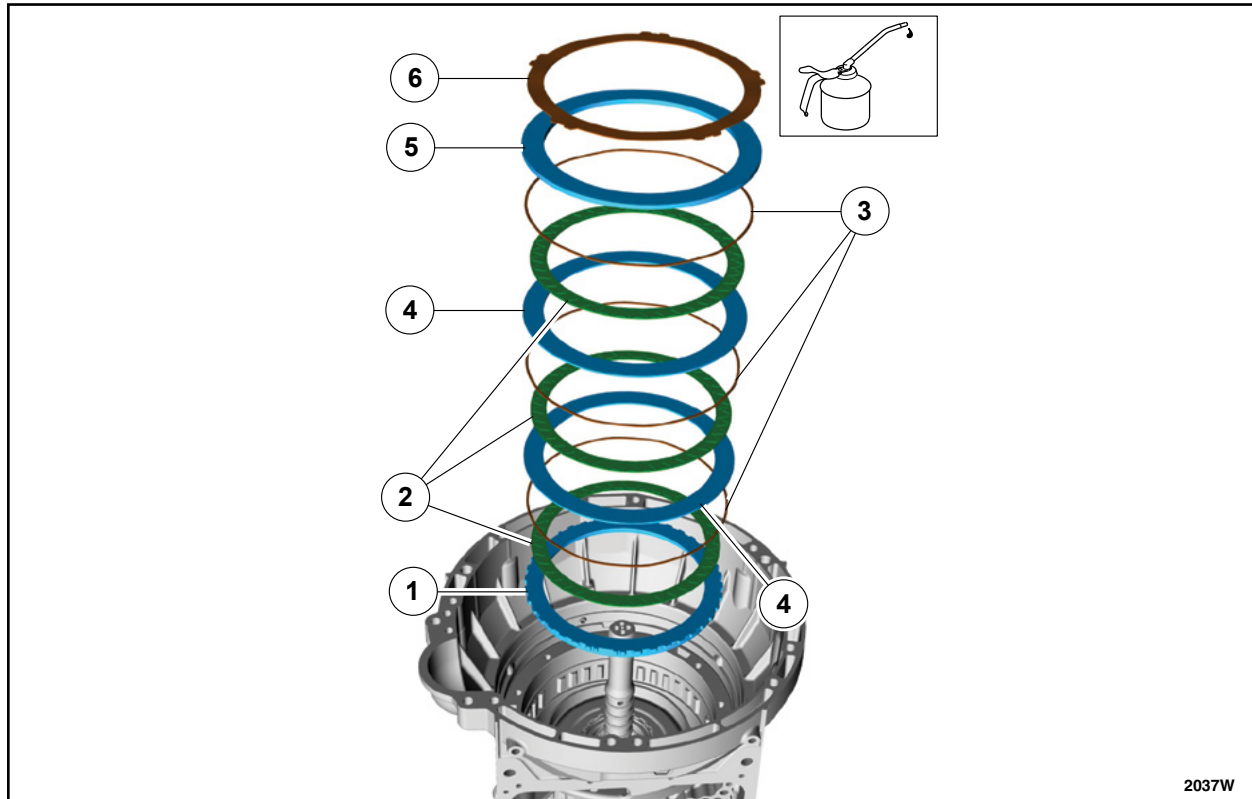

FIGURE 16



20. Inspect the input shaft seals for damage. See Figure 17. Do any of the input shaft seals show signs of damage?

1. Torque converter seals.
2. Front support assembly seals.

If **YES** - Remove the damaged seals, then proceed to Step 21.

If **NO** - Proceed to Step 27.

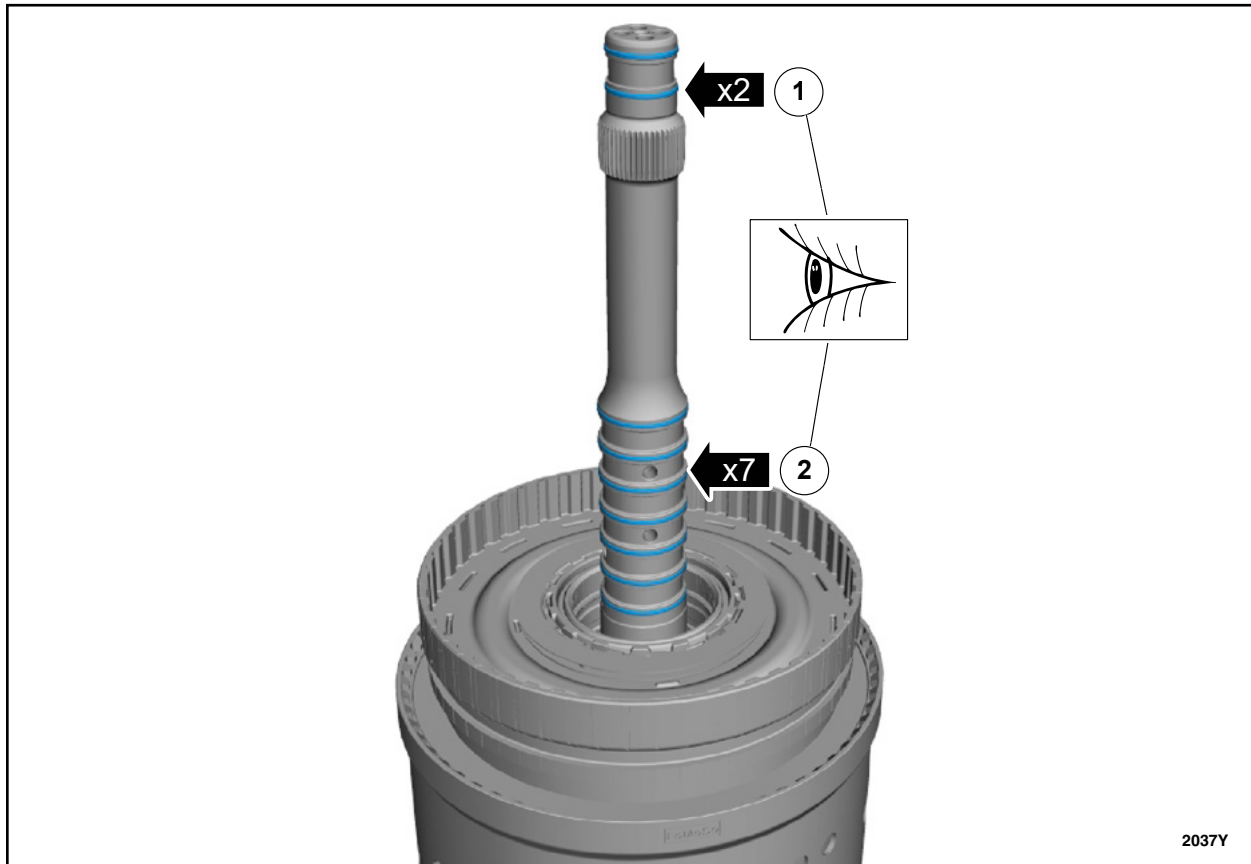
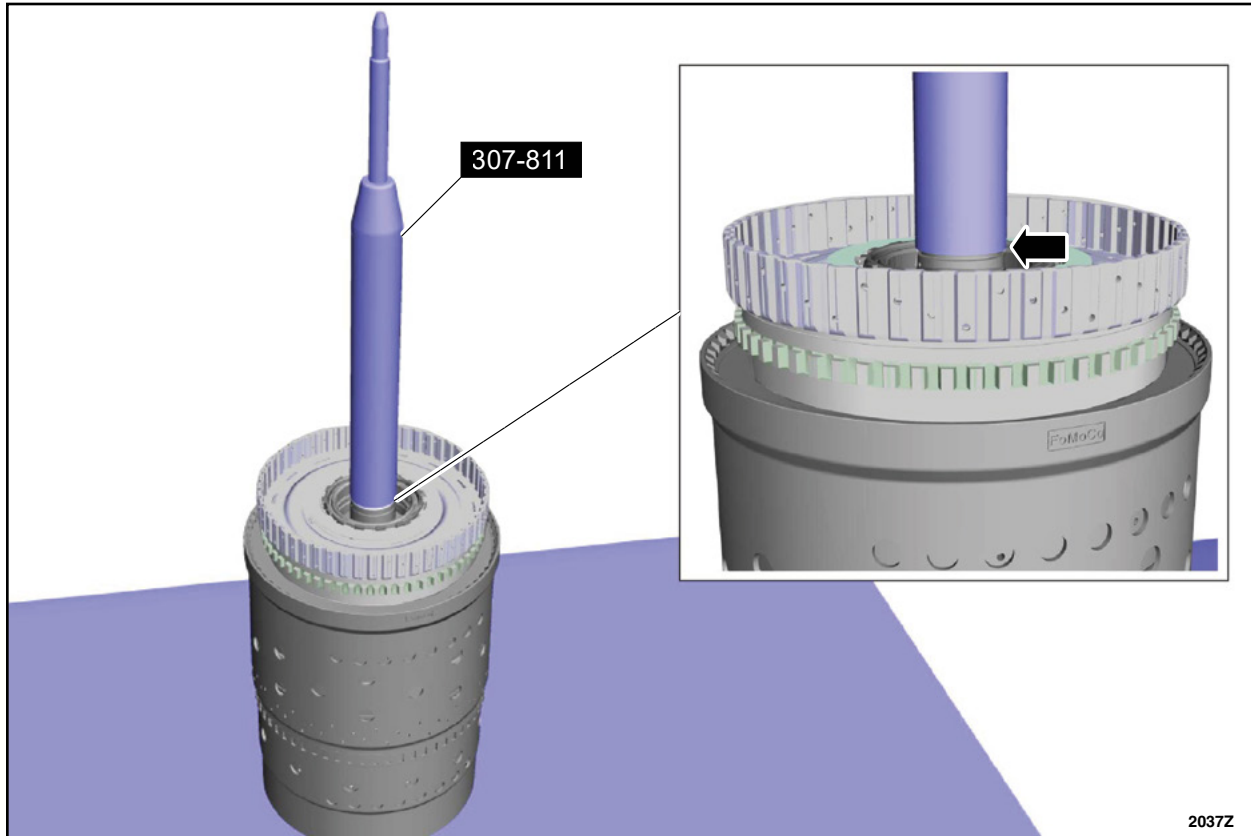

FIGURE 17



**Front Support Assembly Input Shaft Seals - Replace Only As Needed If Damaged**

21. Install special tool 307-811 and adjust it to align the bottom edge of the tool with the top end of the groove of the Teflon® seal being replaced. See Figure 18.



**FIGURE 18**





22. Install a new Teflon® seal on special tool 307-811. Using the top half of special tool 307-811, slide the Teflon® seal into the groove. Remove special tool 307-811 and repeat the steps for the other damaged front support assembly seal. See Figure 19.

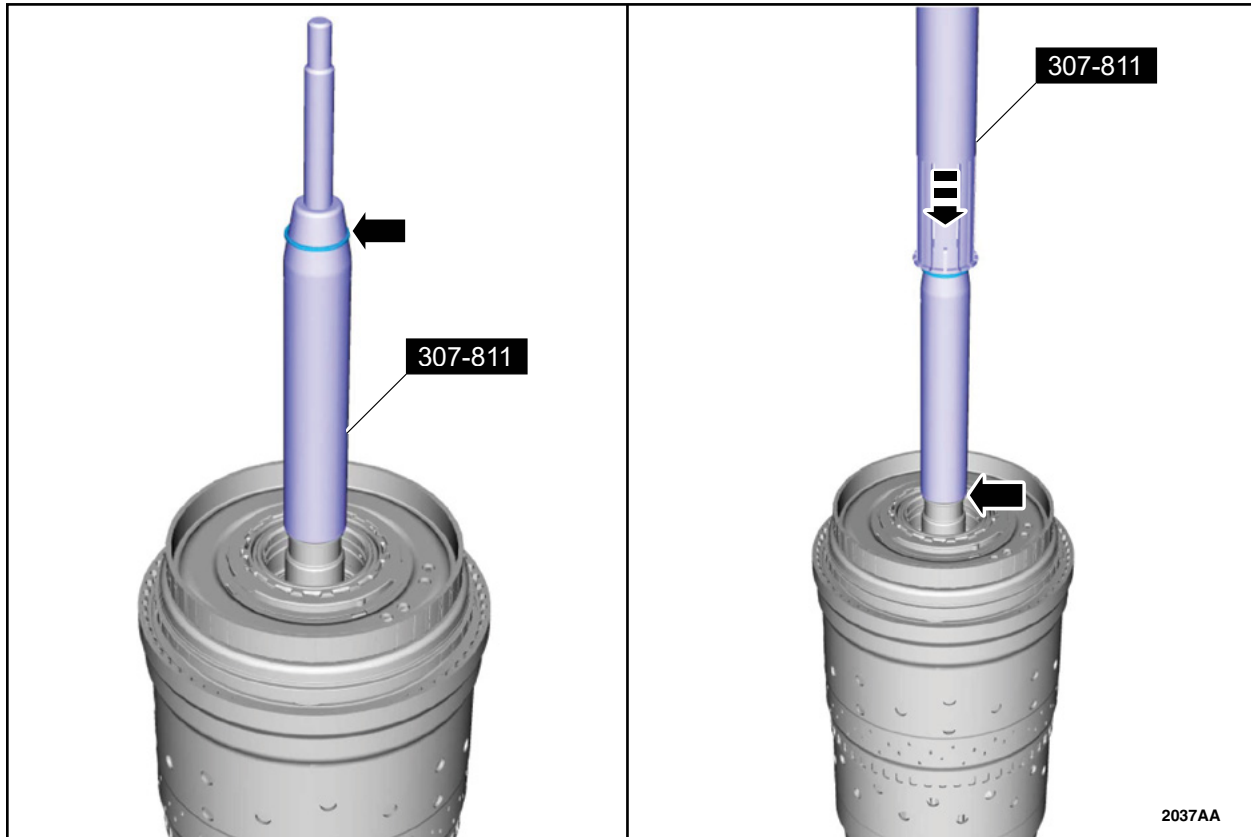
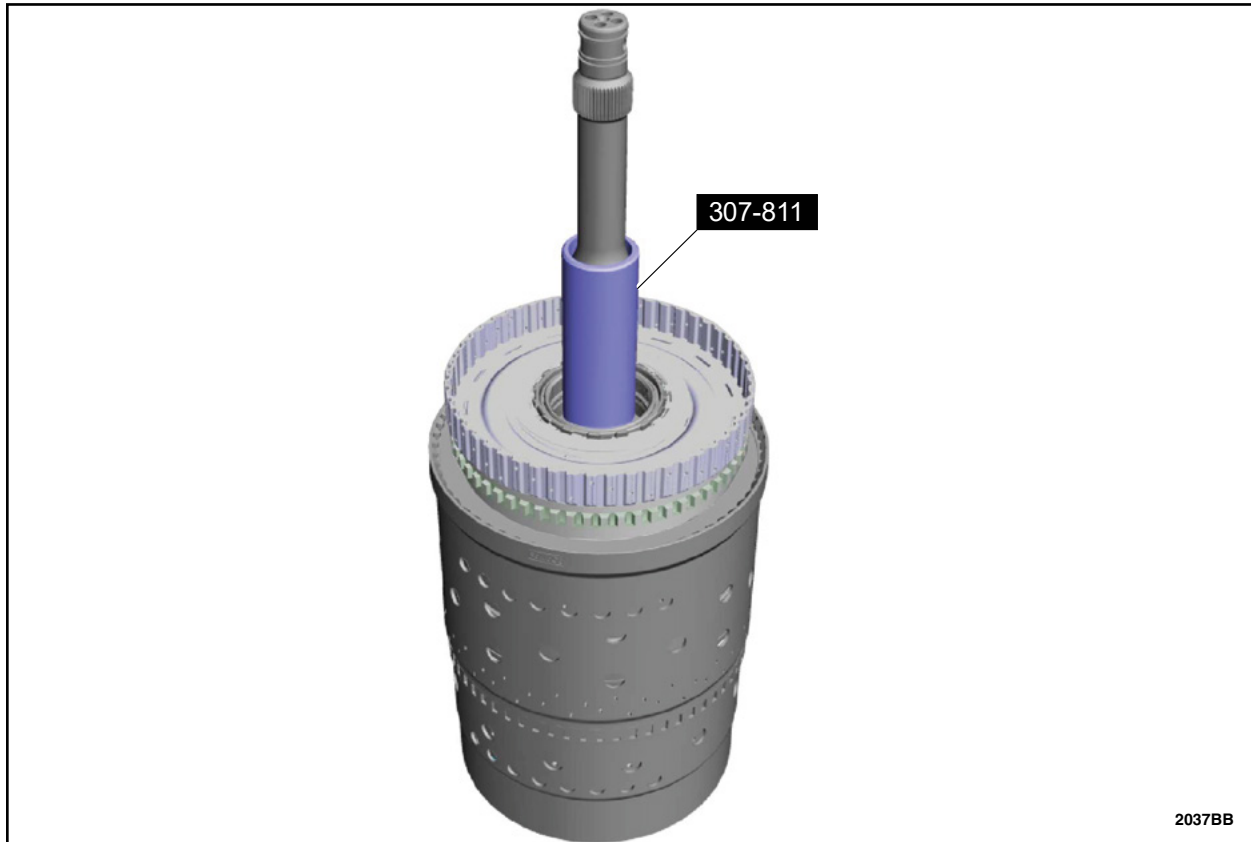

FIGURE 19



23. Install special tool 307-811 to size the 7 Teflon® seals to the input shaft. See Figure 20.

- Allow the special tool to stay on the input shaft until final assembly.

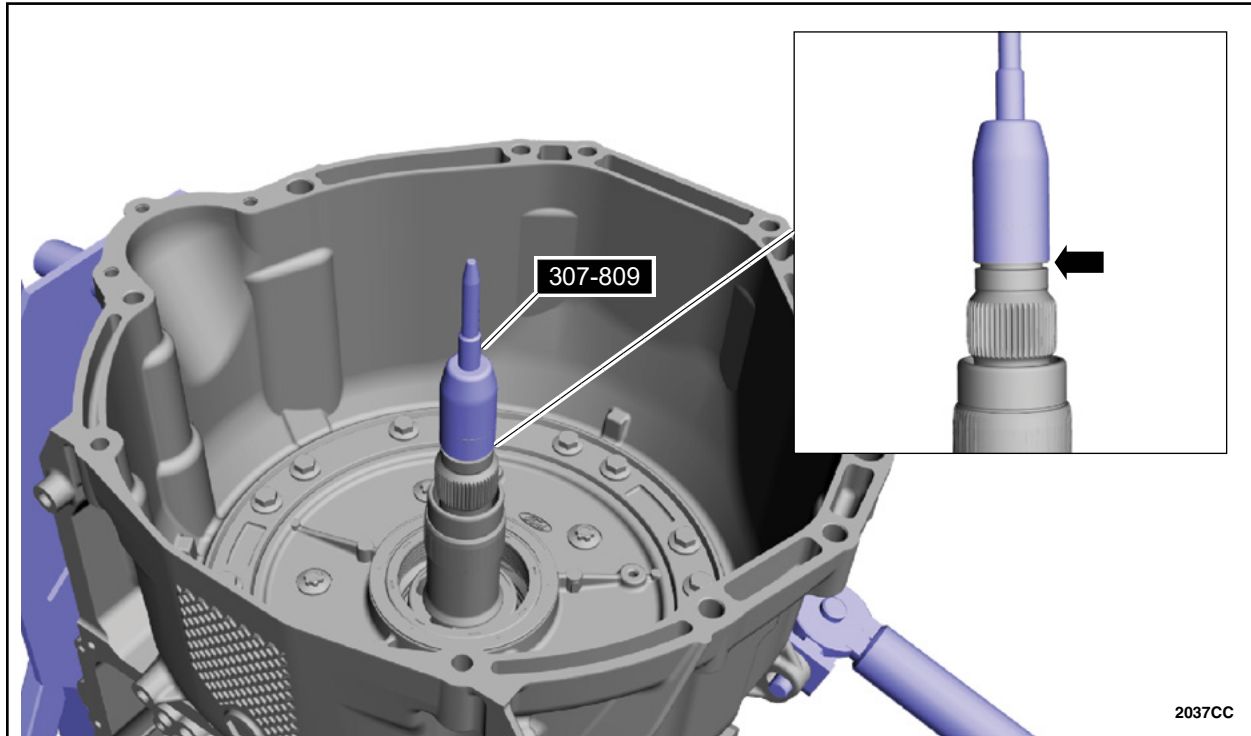

**FIGURE 20**



### Torque Converter Input Shaft Seals - Replace Only As Needed If Damaged

24. Install special tool 307-809 and adjust it to align the bottom edge of the tool with the top end of the groove of the Teflon® seal being replaced. See Figure 21.



**FIGURE 21**

25. Install a new Teflon® seal on special tool 307-809. Using the top half of the special tool, slide the Teflon® seal into the groove. Remove the special tools and repeat the steps for the other damaged torque converter seals. See Figure 22.

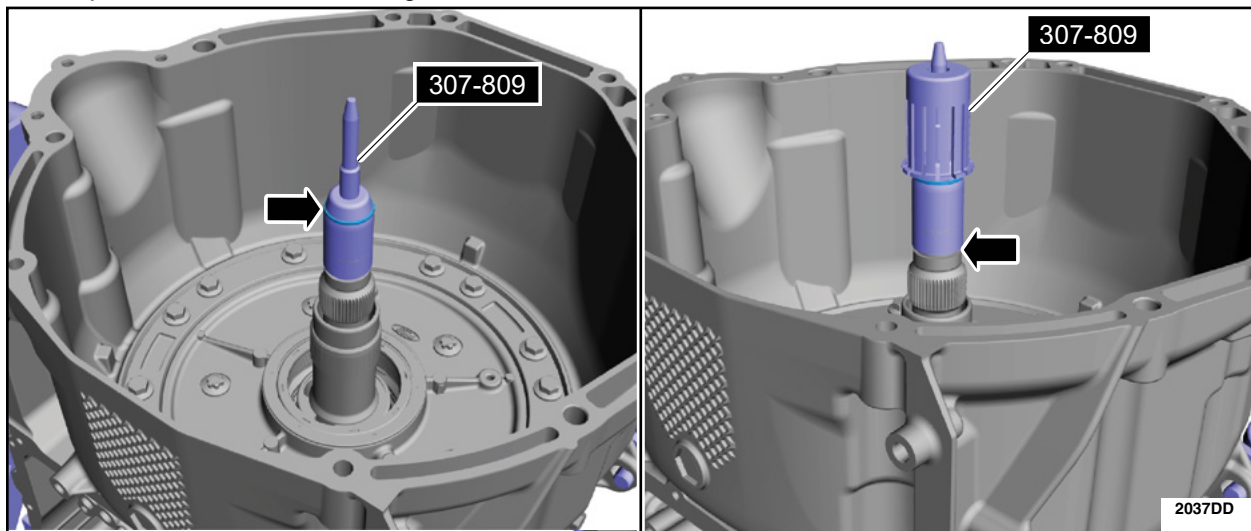

**FIGURE 22**



26. Using the special tool 307-809 and 307-810, size the input shaft torque converter Teflon® seals with a two step process. See Figure 23.

1. Using special tool 307-809, pre-size the input shaft torque converter Teflon® seals.
2. Using special tool 307-810, final size the input shaft torque converter Teflon® seals.

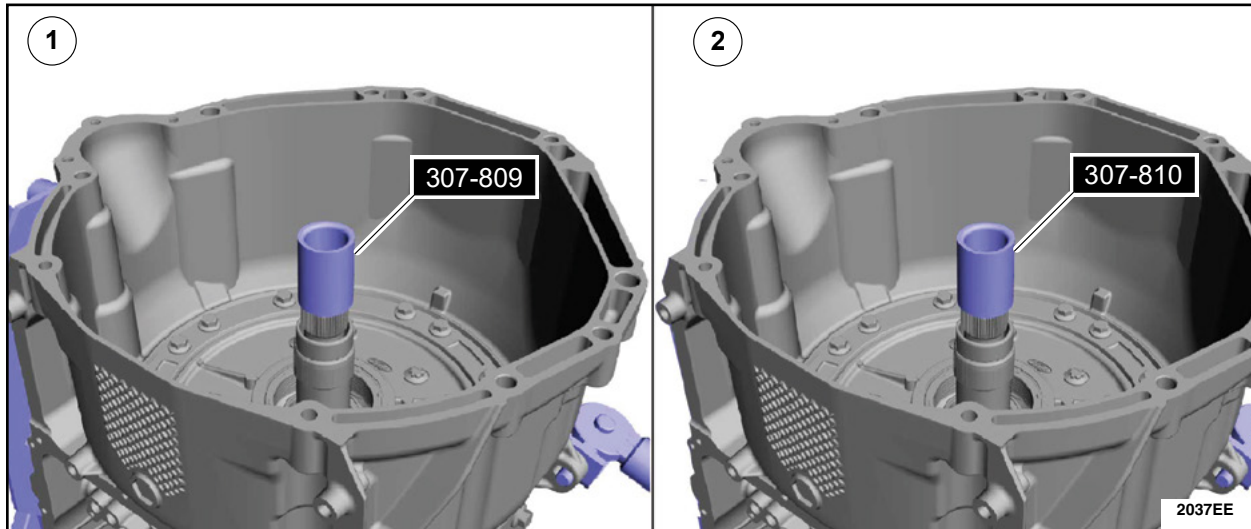

FIGURE 23

27. Install the *new* torque converter hub seal on special tools 205-1018 and 307-807. Using the special tools and a rubber mallet, install the *new* torque converter hub seal. See Figure 24.

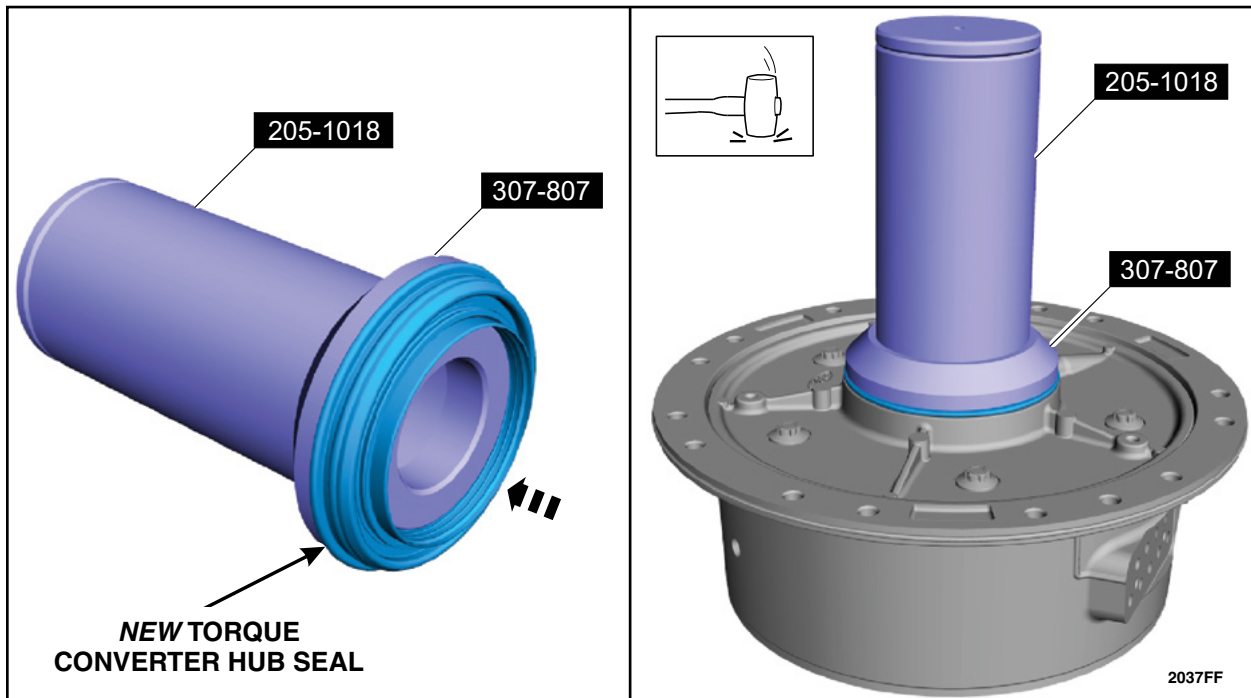

FIGURE 24



28. Install the *new* front support-to-case seal. Lubricate the seal with petroleum jelly. See Figure 25.

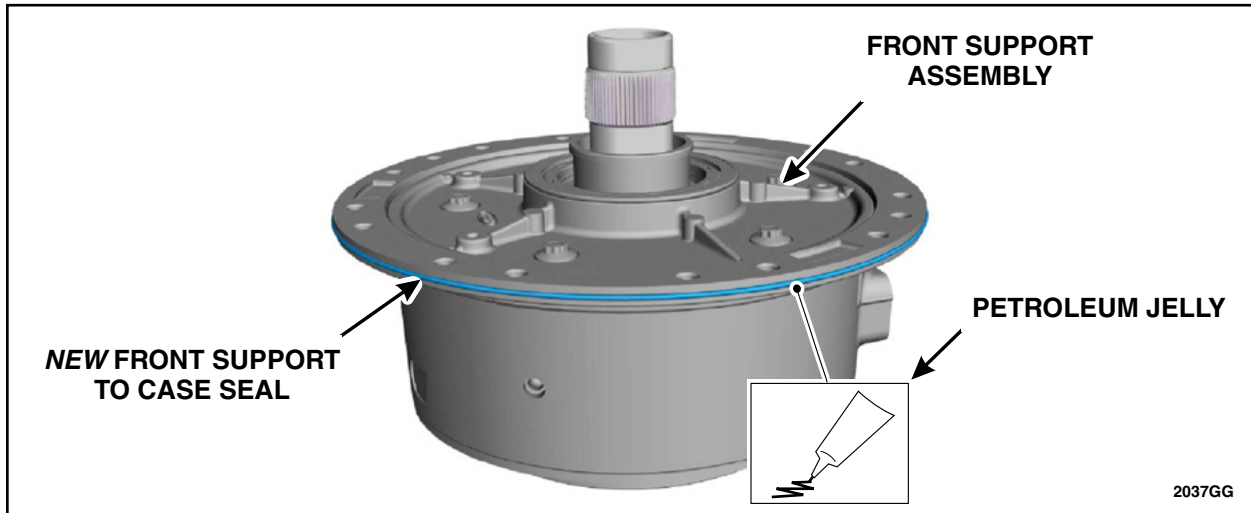

FIGURE 25

29. Install special tools 307-741 and 307-741-01 onto the front support assembly. See Figure 26.

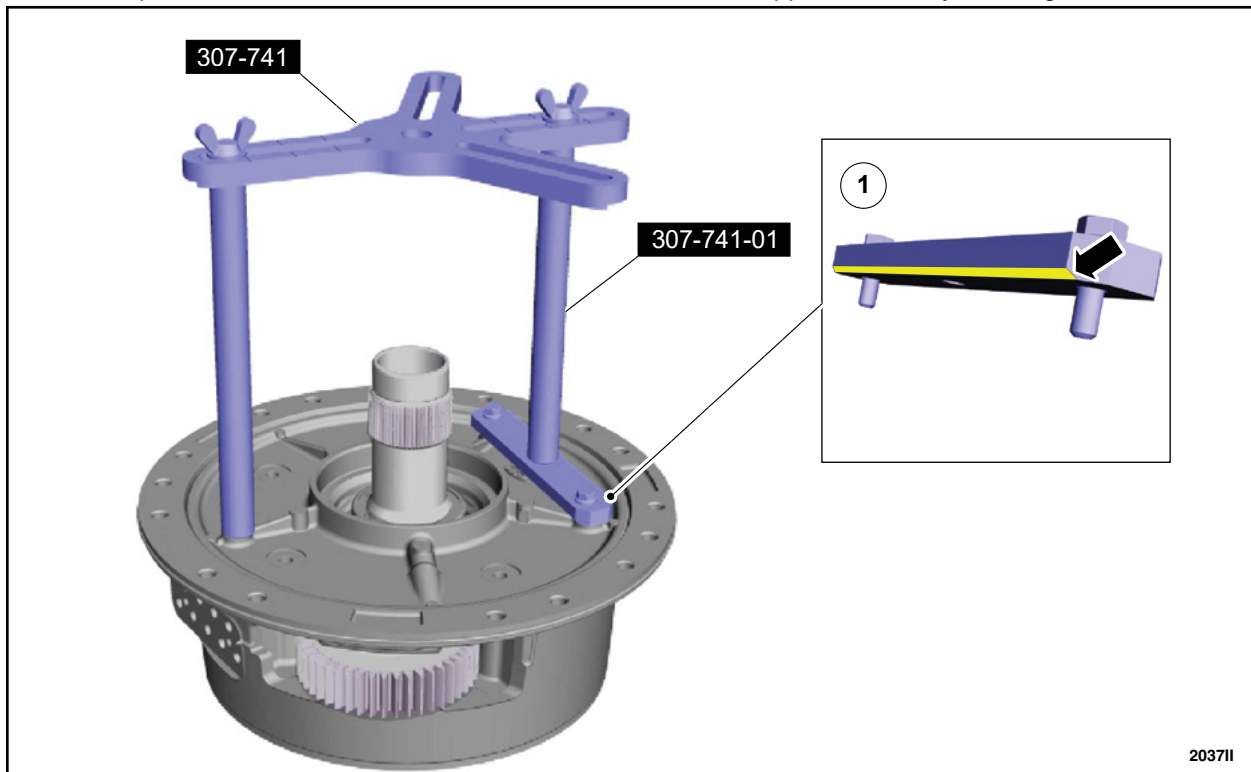
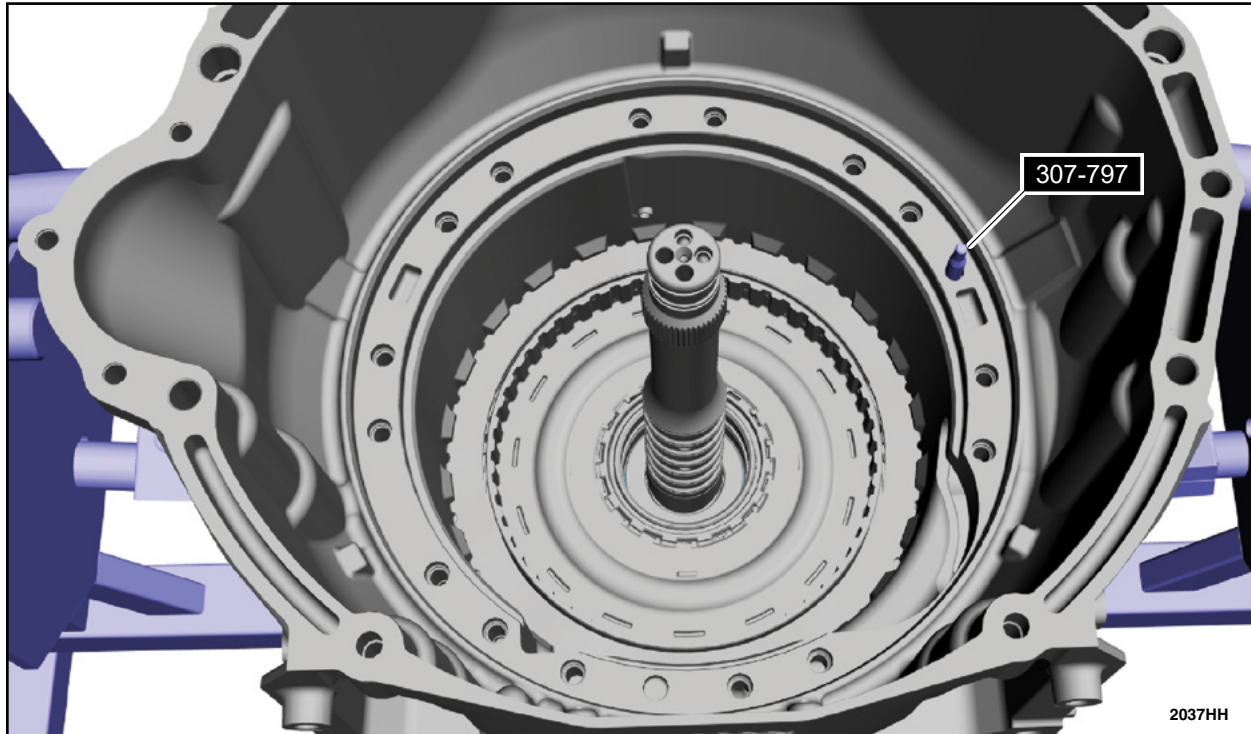

FIGURE 26





30. Install special tool 307-797 in the location shown. See Figure 27.



**FIGURE 27**

31. Lubricate the transmission case-to-front support sealing surface, and the Teflon® seals with petroleum jelly. See Figure 28.

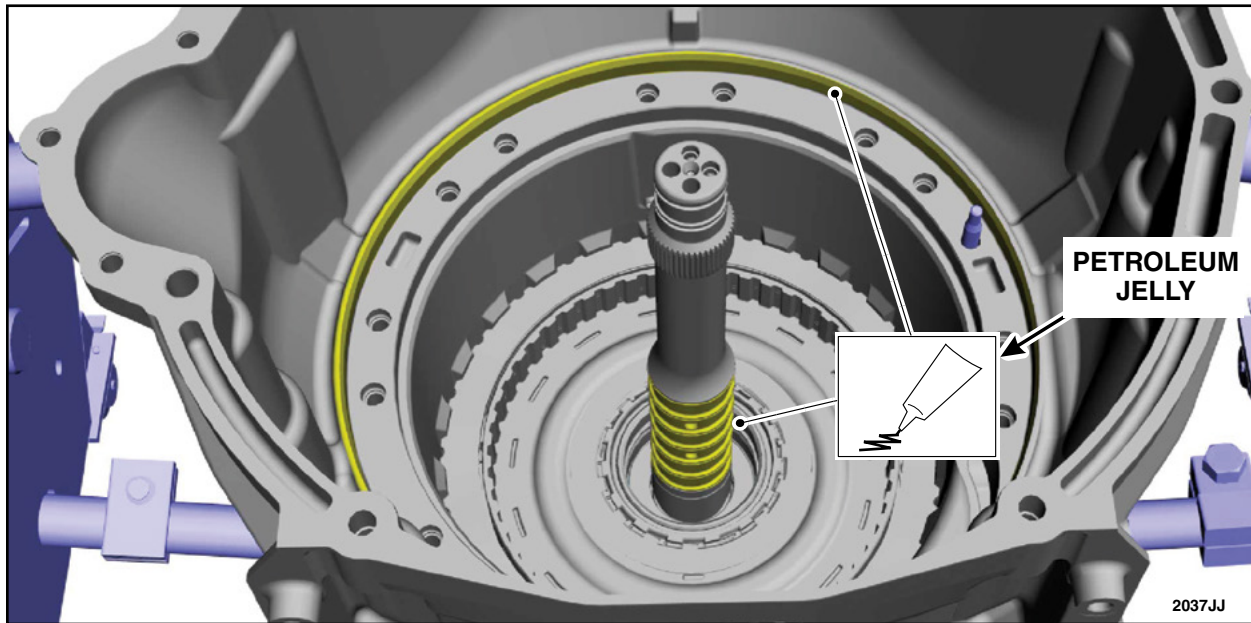

**FIGURE 28**



32. Using the special tools 307-741 and 307-741-01, install the front support into the transmission case. Rotate the input shaft while aligning the front support to the special tool guide pin 307-797. See Figure 29.

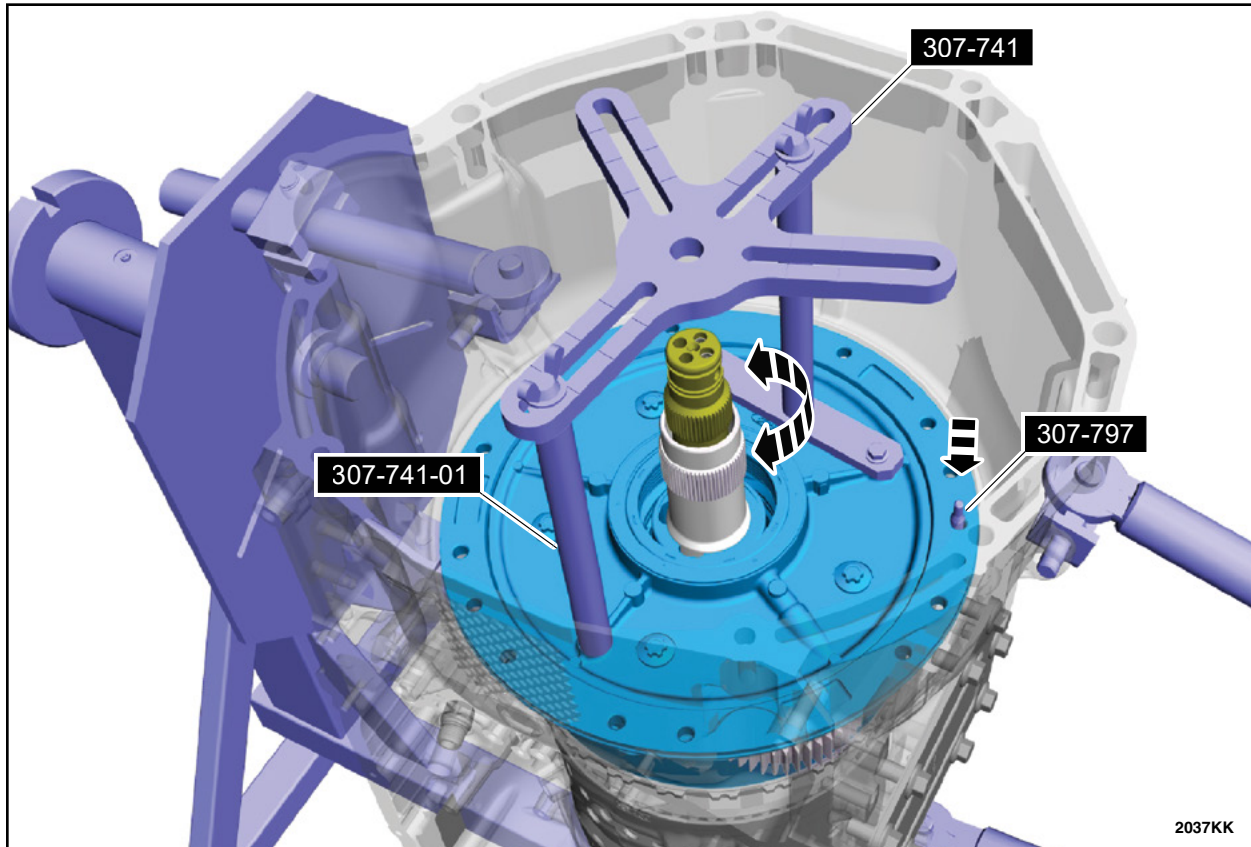

FIGURE 29



33. Install special tool 307-797 studs, washers and nuts in the location shown. See Figure 30.

- Tighten the special tool 307-797 nuts evenly to seat the front support assembly to the transmission case.

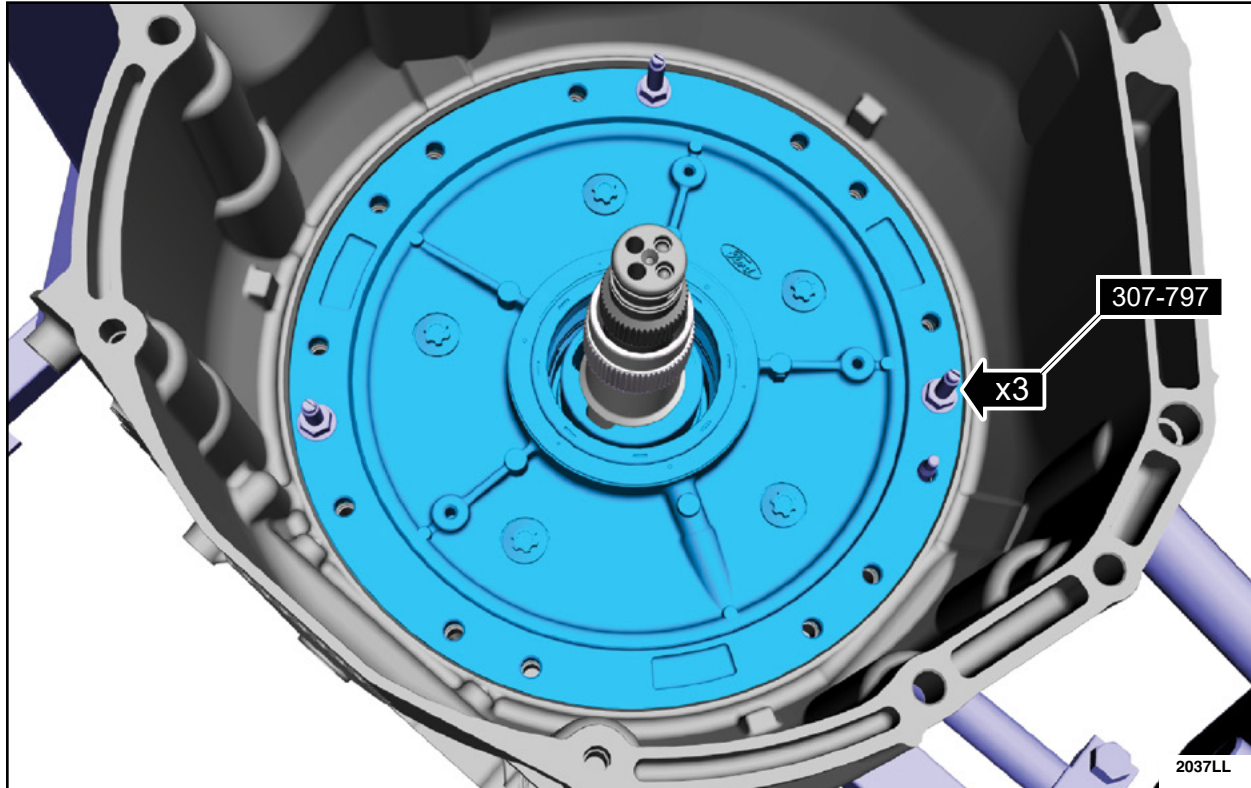

FIGURE 30

34. Install the new front support assembly bolt washers. See Figure 31.



FIGURE 31





35. With the special tools 307-797 installed, hand tighten the front support bolts in a crisscross pattern.

- Remove the special tools 307-797 and install the front support bolts hand tight. See Figure 32.



FIGURE 32

36. Tighten the bolts in the sequence shown. See Figure 33.

- Torque: 30 lb.ft (40 Nm).

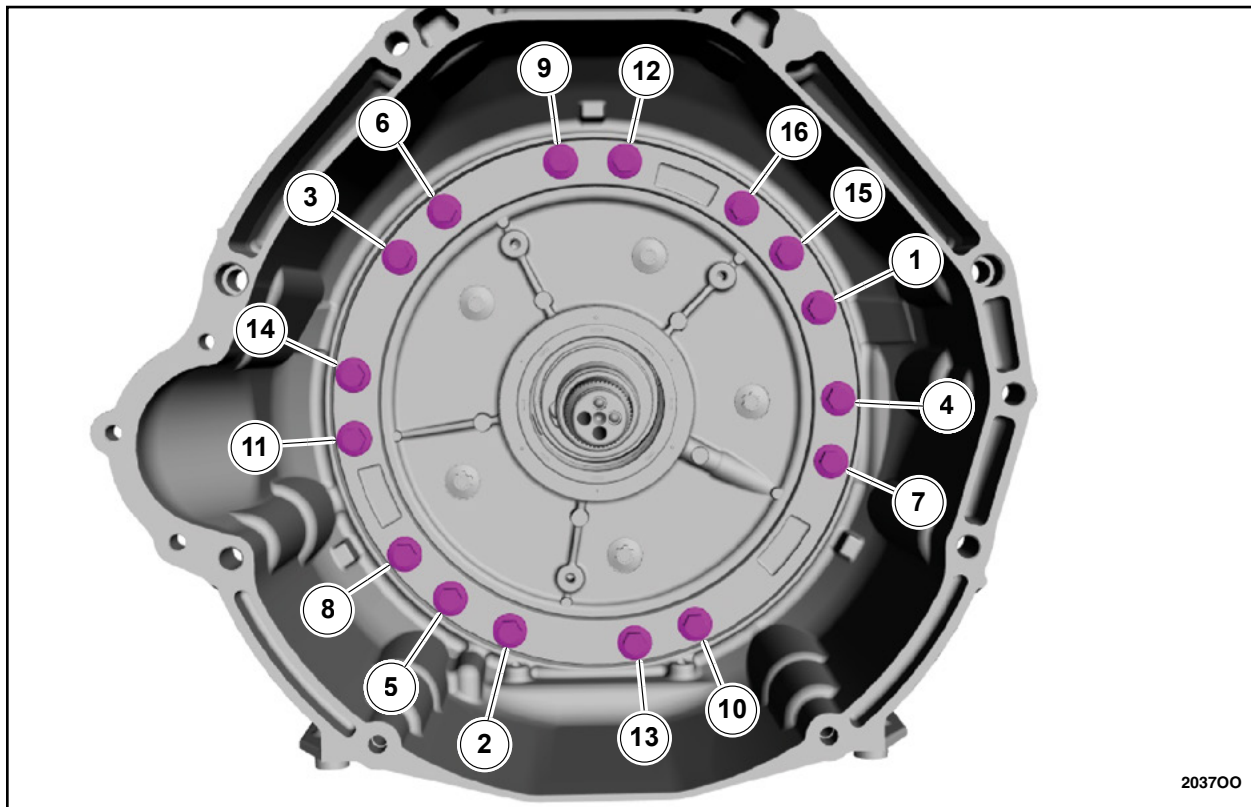

FIGURE 33



37. Using special tool 307-651 and a floor crane, install the torque converter. See Figure 34.

1. Horizontal pin is in the bottom hole.
2. Vertical pin prevents part movement.

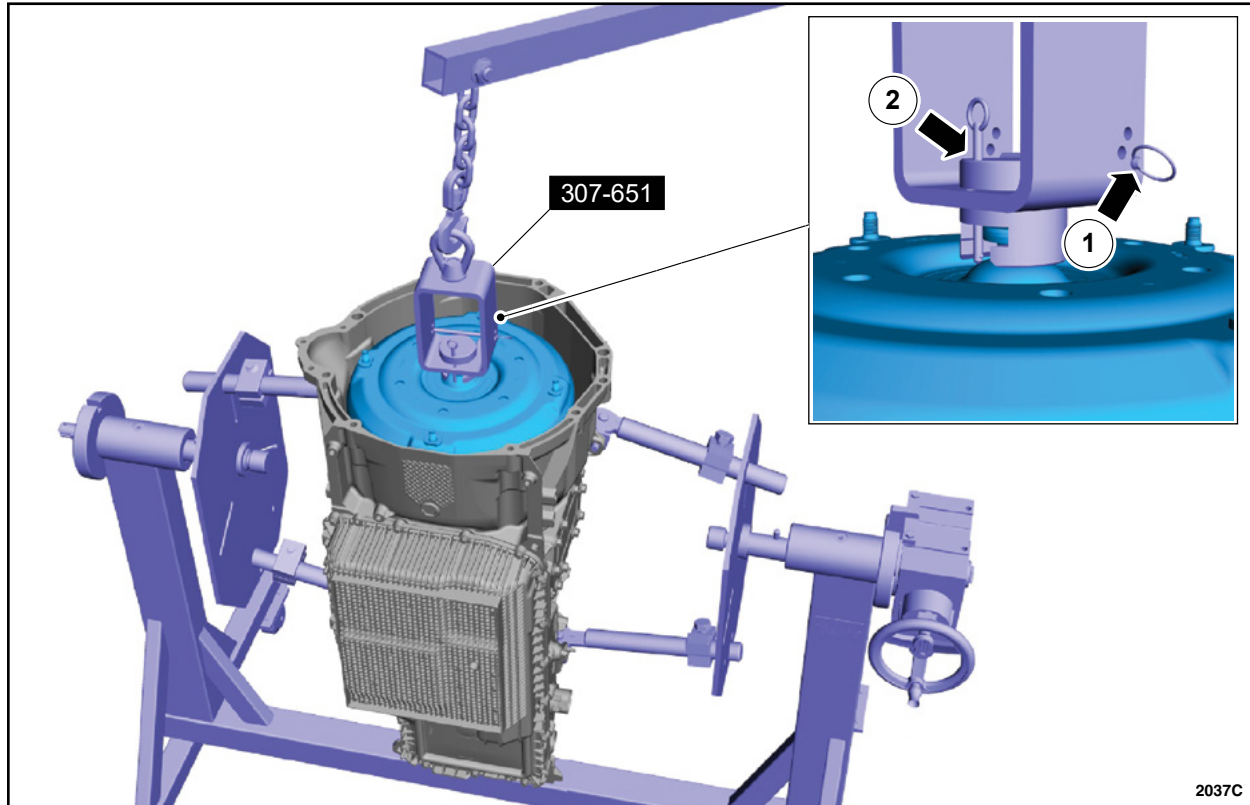
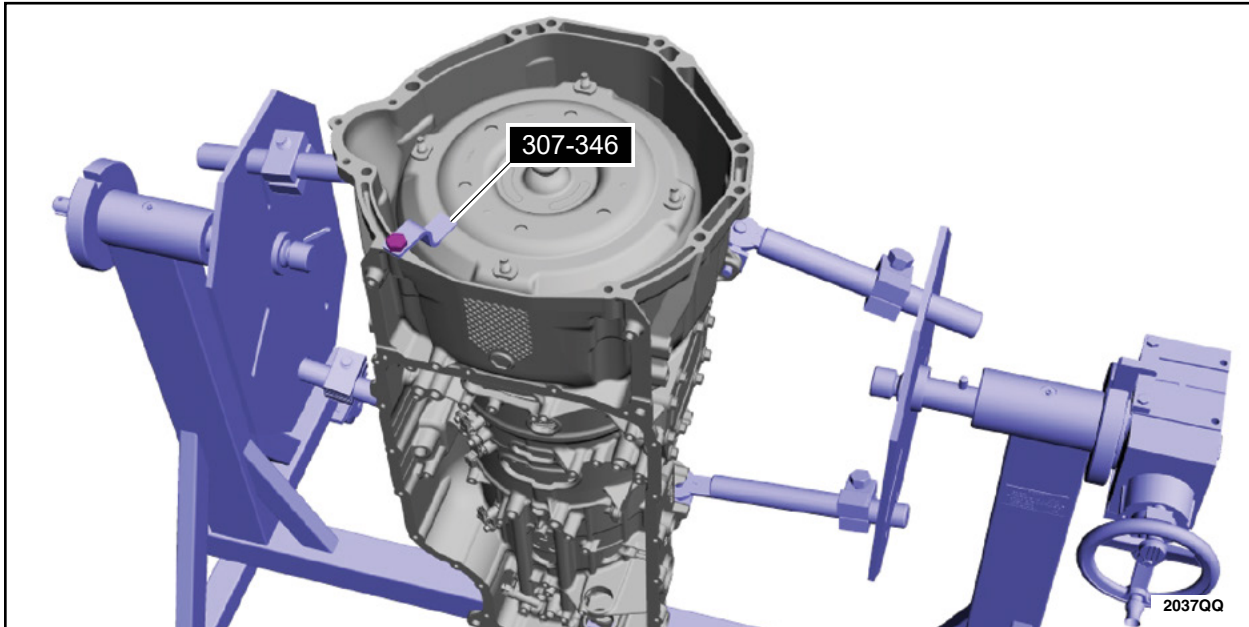

FIGURE 34



38. Install special tool 307-346 to hold the torque converter. See Figure 35.



**FIGURE 35**

39. Install the transmission fluid pump seal. See Figure 36.

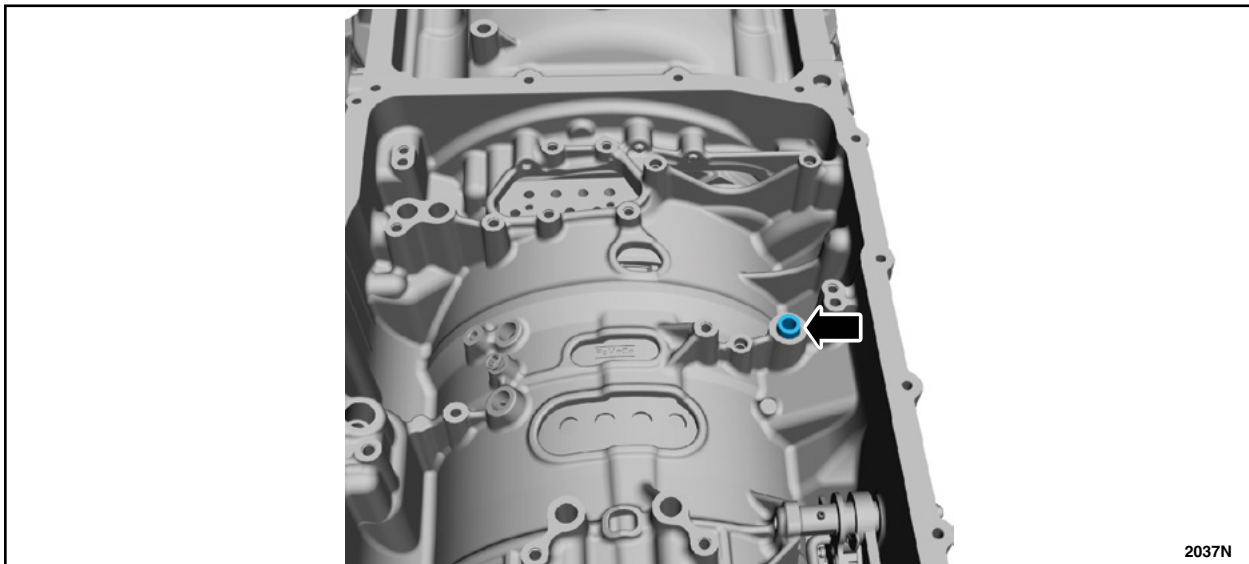

**FIGURE 36**



**NOTE:** Use a 10ep Torx Plus® socket for the transmission fluid pump bolts.

40. Install the transmission fluid pump and the bolts. See Figure 37.

- Torque: 97 lb.in (11 Nm).

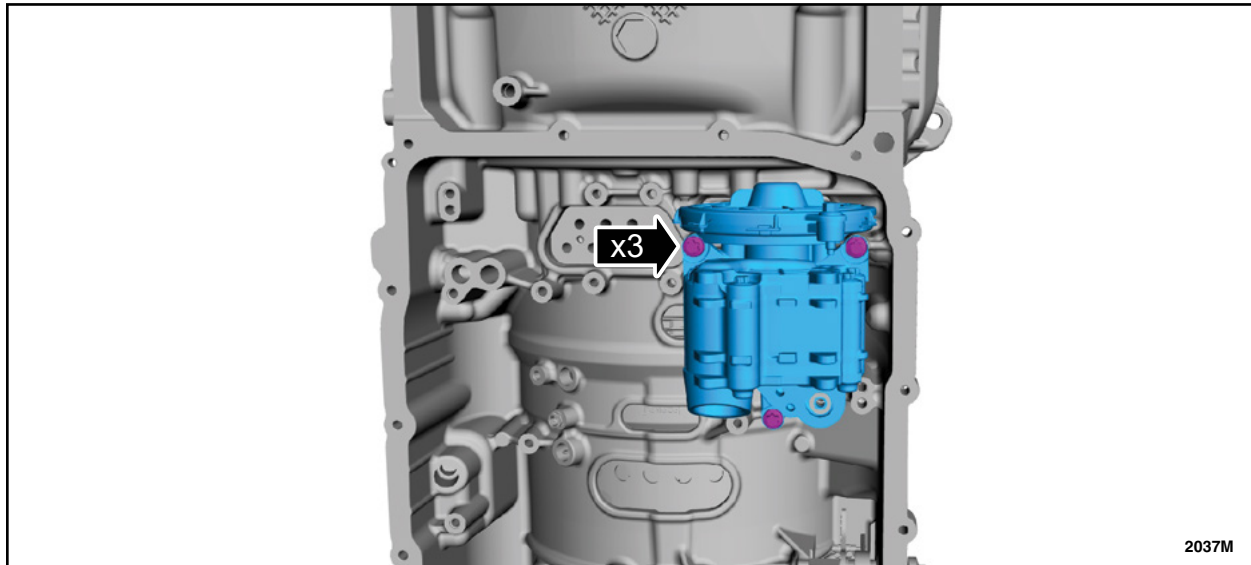

**FIGURE 37**

41. Install the intermediate sensor A. Please follow the WSM procedures in Section 307-01B.
42. Install the main control valve body. Please follow the WSM procedures in Section 307-01B.
43. Remove the transmission from the mounting stand and install the transmission into the vehicle. Please follow the Workshop Manual (WSM) procedures in Section 307-01B.

**IMPORTANT NOTE:** Federal law prohibits selling motor vehicle parts or components that are under safety, compliance, or emissions recall. Unless a part is requested to be returned to Ford, all parts replaced under this FSA must be scrapped in accordance with all applicable local, state and federal environmental protection and hazardous material regulations. Refer to the Parts Retention, Return, & Scrapping section of the FSA dealer bulletin for further information.





Ford Motor Company  
Ford Customer Service Division  
P. O. Box 1904  
Dearborn, Michigan 48121

March 2020

Customer Satisfaction Program 21B03

Mr. John Sample  
123 Main Street  
Anywhere, USA 12345

Your Vehicle Identification Number (VIN): 12345678901234567

At Ford Motor Company, we are committed not only to building high quality, dependable products, but also to building a community of happy, satisfied customers. To demonstrate that commitment, we are providing a no-charge Customer Satisfaction Program for your vehicle with the VIN shown above.

**Why are you receiving this notice?** On your vehicle, a bearing within the transmission could wear prematurely, resulting in rough shifts.

**What is the effect?** This bearing wear may result in a wrench light. As damage progresses, the transmission may only be capable of limited vehicle speed or may not engage in forward or reverse.

**What will Ford and your dealer do?** In the interest of customer satisfaction, Ford Motor Company has authorized your dealer to replace the planetary one and ring gear assembly free of charge (parts and labor) under the terms of this program.  
This Customer Satisfaction Program will be in effect until March 31, 2022 regardless of mileage. Coverage is automatically transferred to subsequent owners.

**How long will it take?** The time needed for this repair is approximately two days. However, due to service scheduling requirements, your dealer may need your vehicle for a longer period of time. In addition, your vehicle may require an inspection to determine if additional parts need to be ordered.

**What should you do?** Please call your dealer without delay to schedule a service appointment for Customer Satisfaction Program 21B03. Provide the dealer with your VIN, which is printed near your name at the beginning of this letter.  
If you do not already have a servicing dealer, you can access [owner.ford.com](https://owner.ford.com) for dealer addresses, maps, and driving instructions.



**What should you do?  
(continued)**

Ford Motor Company wants you to have this service action completed on your vehicle. The vehicle owner is responsible for making arrangements to have the work completed. Ford Motor Company can deny coverage for any vehicle damage that may result from the failure to have this service action performed on a timely basis. Therefore, please have this service action performed as soon as possible.

NOTE: You can receive information about Recalls and Customer Satisfaction Programs through our FordPass App. The app can be downloaded through the App Store or Google Play. In addition there are other features such as reserving parking in certain locations and controlling certain functions on your vehicle (lock or unlock doors, remote start) if it is equipped to allow control.

**COVID-19  
(CORONAVIRUS)**

Ford dealerships have implemented enhanced protocols to ensure both your safety and the safety of dealership employees. This includes specific procedures for cleaning and disinfecting customer vehicles before and after each vehicle is serviced. In most places, vehicle service has been deemed a critical service. Please contact your local dealer to confirm current service hours. For more information on how Ford and your local dealer are working hard to keep you on the road during these challenging times, please visit [owner.ford.com](http://owner.ford.com).

**Do you need a rental vehicle?**

Your dealer is authorized to provide a rental vehicle (non-commercial and non-fleet vehicles) for your personal transportation at no charge (except for fuel, insurance, and tax) while your vehicle is at the dealership for repairs. Please see your dealer for guidelines and limitations.

**Have you previously paid for this repair?**

If you have previously paid for a repair that addresses the issue described in this letter, you still need to have this service action performed to ensure the correct parts were used.

If the previously paid for repair was performed before the date of this letter, you may be eligible for a refund. Refunds will only be provided for service related to replace the planetary one and ring gear assembly. To verify eligibility and expedite reimbursement, give your paid original receipt to your dealer before **September 30, 2021**. To avoid delays, do not send receipts to Ford Motor Company.

**What if you no longer own this vehicle?**

If you no longer own this vehicle, and have an address for the current owner, please forward this letter to the new owner.

You received this notice because our records, which are based primarily on state registration and title data, indicate that you are the current owner.

**Can we assist you further?**

If you have difficulties getting your vehicle repaired promptly and without charge, please contact your dealership's Service Manager for assistance.

RETAIL OWNERS: If you have questions or concerns, please contact our **Ford Customer Relationship Center at 1-866-436-7332** and one of our representatives will be happy to assist you. If you wish to contact us through the Internet, our address is: [owner.ford.com](http://owner.ford.com).

**Can we assist you  
further?  
(continued)**

For the hearing impaired call 1-800-232-5952 (TDD). Representatives are available Monday through Friday: 8:00AM – 8:00PM (Eastern Time).

FLEET OWNERS: If you have questions or concerns, please contact our **Fleet Customer Information Center at 1-800-34-FLEET**, choose Option #3, and one of our representatives will be happy to assist you. If you wish to contact us through the Internet, our address is: [fleet.ford.com](http://fleet.ford.com).

Representatives are available Monday through Friday: 8:00AM - 8:00PM (Eastern Time).

MOTORHOME OWNERS: If you have questions or concerns, please contact our **Motorhome Customer Assistance Center toll free at 1-866-906-9811**. Representatives are available 24 hours a day.

Thank you for your attention to this important matter.

Ford Customer Service Division