

ATTENTION:
 GENERAL MANAGER
 PARTS MANAGER
 CLAIMS PERSONNEL
 SERVICE MANAGER

IMPORTANT - All Service Personnel Should Read and Initial in the boxes provided, right.

© 2020 Subaru of America, Inc. All rights reserved.



QUALITY DRIVEN® SERVICE

SERVICE PROGRAM BULLETIN

APPLICABILITY: 2019MY Crosstrek
SUBJECT: Rear Seat Belt Webbing Locking

NUMBER: WRA-20R
DATE: 02/25/20
REVISED: 04/01/20

- April, 2020:**
- This service program (WRA-20) has been superseded to the WRC-20 Rear Seat Belt Webbing Locking recall.*
 - If a WRA-20 claim was approved prior to the release of the WRC-20 recall, the VIN will not be included in the WRC-20 recall.*
 - On April 1, 2020 any incomplete WRA-20 service program applicability was expired in SOA's system.*
 - Claims for WRA-20 repairs submitted after this expiration date should be submitted for reimbursement under the WRC-20 recall.*
 - Coverage for all affected vehicles must be confirmed by using the Vehicle Coverage Inquiry function on subarunet.com.*
 - Please refer to the WRC-20 recall bulletin for more detail.*

INTRODUCTION:

In the interest of customer satisfaction, Subaru of America, Inc. (Subaru) is initiating a service program to replace the LH and RH Rear Seat Lap-Shoulder Seat Belt Assemblies in certain 2019MY Crosstrek vehicles. The improper installation of a pawl spring during manufacturing could reduce the operating sensitivity of the webbing sensor which may affect the seat belt locking function. However, these seat belt assemblies are equipped with dual locking mechanisms; a webbing sensor lock and a G-sensor lock. The G-sensor lock performance is not affected by this condition and as a result, the vehicle maintains FMVSS compliance through the use of the G-sensor which can engage the locking function of the seat belt.

AFFECTED VEHICLES:

Model Year	Carline	Production Range	VIN Range
2019	Crosstrek	August 22, 2019 – September 13, 2019	K8384655 - KH393012

Coverage for all affected vehicles must be confirmed by using the Vehicle Coverage Inquiry function on subarunet.com. This information is now available.

<p>CAUTION: VEHICLE SERVICING PERFORMED BY UNTRAINED PERSONS COULD RESULT IN SERIOUS INJURY TO THOSE PERSONS OR TO OTHERS.</p>	<p>Subaru of America, Inc. is ISO 14001 Compliant</p>
<p>Subaru Service Bulletins are intended for use by professional technicians ONLY. They are written to inform those technicians of conditions that may occur in some vehicles, or to provide information that could assist in the proper servicing of the vehicle. Properly trained technicians have the equipment, tools, safety instructions, and know-how to do the job correctly and safely. If a condition is described, DO NOT assume that this Service Bulletin applies to your vehicle, or that your vehicle will have that condition.</p>	<p>ISO 14001 is the international standard for excellence in Environmental Management Systems. Please recycle or dispose of automotive products in a manner that is friendly to our environment and in accordance with all local, state and federal laws and regulations.</p>

Continued...

DESCRIPTION OF THE REPAIR:

Subaru retailers will replace the LH and RH Rear Seat Lap-Shoulder seat belt assemblies.

RETAILER RESPONSIBILITY:

Retailers are to promptly perform this repair on any affected vehicles that may be in their inventory. Additionally, whenever a vehicle subject to this service program is taken into inventory or in for service, necessary steps should be taken to ensure the repair has been made before selling or releasing the vehicle.

Any vehicles listed in a service program that are in the retailer's stock must be:

- Immediately identified
- Tagged or otherwise marked to prevent their delivery or use prior to inspection and/or repair
- Updated in accordance with the repair procedures outlined in this Service Program Bulletin.

OWNER NOTIFICATION:

Subaru is in the process of acquiring registration data and expects to notify affected vehicle owners by first class mail beginning in March 2020. Retailers will be advised when owner notification occurs.

RETAILER AFFECTED VIN LISTS:

Each Subaru retailer will receive an affected VIN list from their Zone Office when owner notification begins. Vehicles will be assigned to retailers in the affected VIN list based on the selling retailer.

PARTS INFORMATION:

Description	Part Number	Application	Position Code	ID Code
BELT ASSY R OUT 5DR	64660FL3609S*	Right Side Outer	5RH	HH
	64660FL3709S*	Left Side Outer	5LH	HH

**Parts for completing this service program must be ordered through PRIME.*

IMPORTANT: Always confirm the part numbers of the replacement parts as shown in the table above to be sure the correct parts are ordered.

NOTE: Position Code and ID Code details are provided in the Service Procedure section below.

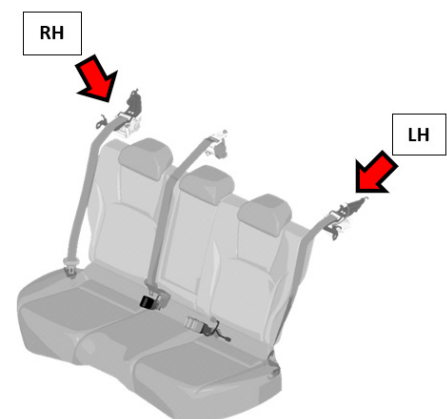

Continued...

SERVICE PROCEDURE:

IMPORTANT: The use of **HAND TOOLS ONLY** is **strongly recommended** when performing these repairs. The use of air tools for bolt removal or installation may result in thread or weld nut damage. Weld nut damage may result in costly body panel replacement and would not be a matter for warranty. Work **CAREFULLY** using **hand tools only** along with a properly calibrated torque wrench to ensure all bolts are tightened and torqued to proper specification as part of this repair procedure.

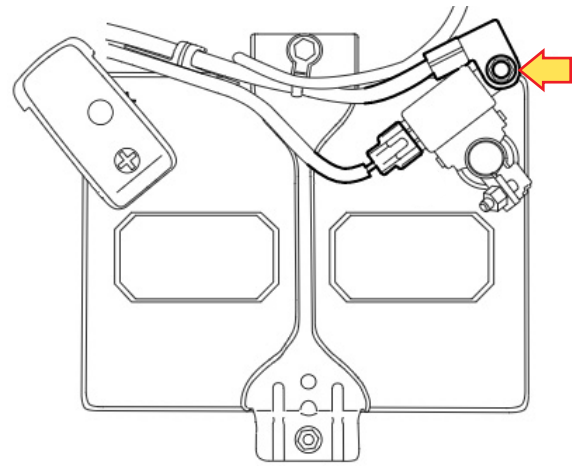

This service procedure outlines replacement of both the left and right-hand outer seat belt assemblies. The center seat belt is **not** affected.

- Record all radio presets and navigation favorites (where applicable) for later reinstallation.
- Disconnect the negative battery cable from the 12V engine restart battery sensor (NEVER disconnect at the battery terminal itself) and always wait **at least 60** seconds before proceeding work to prevent any malfunction of the airbag pretensioner.
- When removing the negative battery cable from the battery sensor, **always support it and hold it in place with one hand** while loosening the retaining nut. Doing so will prevent battery sensor damage / deformation from unnecessary movement.
- **CAREFULLY** remove the necessary interior trim panels for seat belt access along with the rear seat cushion following the procedures in the applicable Service Manual and set them aside in a safe place.

CAUTION: The airbag system satellite safing sensor is located under the front center of the rear seat cushion. Be careful not to apply any strong impact force to the sensor while working in that area with the seat cushion removed.

- **After seat belt removal, mark the tag with a permanent marker** as shown here to distinguish the old part from the replacement (new) part. If by chance the old parts become confused with the new parts, check the date code to identify the new seat belt assemblies using the photo below as a guide.

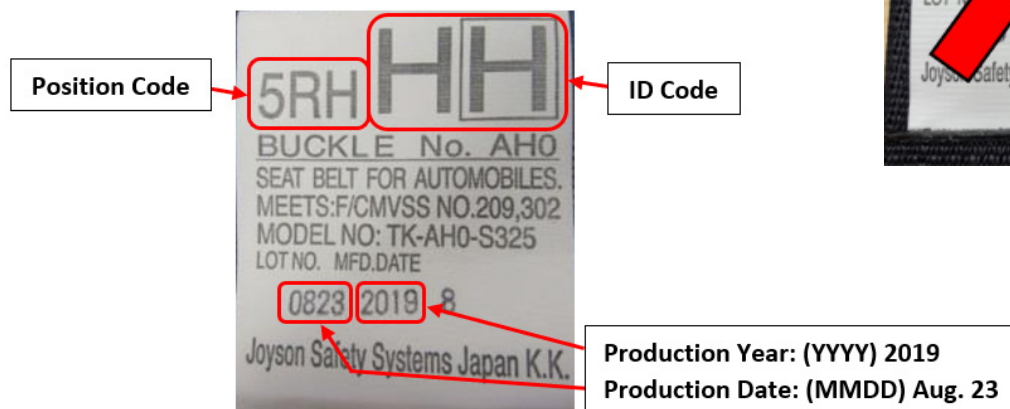

- Install the new outer seat belt assemblies in reverse order of removal. Confirm the new seat belt webbing is not twisted and can be pulled out and retracted smoothly.

Continued...

VERY IMPORTANT: Confirm both the Emergency Locking Retractor (ELR) and Automatic Locking Retractor (ALR) operation of both new seat belts:

- **ELR:** Pull out a short length of belt and then tug it sharply to confirm it locks.
- **ALR:** Pull out the entire length of belt and confirm it retracts, ratchets, tightens and holds when pulled on (ALR).
- Latch BOTH belts and confirm all buckles function properly.
- **CAREFULLY** reinstall the interior trim panels and rear seat cushion in reverse order of removal following the procedures in the applicable Service Manual.
- Reconnect the negative (-) cable to the battery temperature sensor and torque the nut to **7.5 Nm (5.5 ft. lbs.)**. **NOTE:** Never exceed this torque specification as battery sensor damage may result. When installing the negative battery cable from or to the battery sensor, **always support it and hold it in place with one hand** while torquing the retaining nut. Doing so will prevent battery sensor damage / deformation from unnecessary movement.

IMPORTANT REMINDERS:

- After the battery is reconnected, initial diagnosis of the electronic throttle control is performed automatically. Always wait 10 seconds or more after turning the ignition switch ON before starting the engine.
- Reset the customer’s clock, radio presets and navigation favorites (where applicable).
- Confirm auto up / down operation of both front windows. Re-initialize if necessary (due to battery disconnect).
- If the customer had a phone paired to the infotainment system, re-pairing will be required. Assist the customer with this task if necessary.

SERVICE PROGRAM IDENTIFICATION LABEL:

Type or print the necessary information on a Campaign Identification Label. The completed label should be attached to the vehicle’s upper radiator support. Additional labels are available through normal parts ordering channels. The part number is **MSA6P1302**, which comes as one sheet of 20 labels.

Part Number	Applicability	Description	Order Quantity
MSA6P1302	All Models	Campaign Completion Labels (contains one sheet of 20 labels)	1

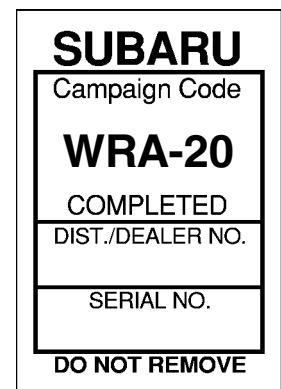

Continued...

CLAIM REIMBURSEMENT AND ENTRY PROCEDURES:

Credit to perform this recall will be based on properly completed repair order information. Retailers may submit claims through Subarunet.com.

Labor Description	Labor Operation #	Labor Time	Fail Code	Claim Type
WRA-20 LEFT & RIGHT REAR OUTER SEAT BELT REPLACEMENT	A191-124	0.8	WRA-20	RC

IMPORTANT REMINDERS:

- SOA strongly discourages the printing and/or local storage of service information as previously released information and electronic publications may be updated at any time.
- Always check for any open recalls or campaigns anytime a vehicle is in for servicing.
- Always refer to STIS for the latest service information before performing any repairs.

Continued...

This notice applies to the VIN identified in the address section printed below



Subaru of America, Inc
PO Box 9103
Camden, NJ 08101-9877
844-373-6614
www.subaru.com

**Subaru Service Program WRA-20
March 2020**

Dear Subaru Owner:

We would like to thank you for your selection of a Subaru vehicle. We take pride in our products and are committed to your continued satisfaction.

Subaru of America, Inc. (Subaru) is initiating a service program to replace the left and right rear lap-shoulder seat belt assemblies in certain 2019 model year Crosstrek vehicles. Our records indicate that you currently own one of these vehicles.

REASON FOR THIS SERVICE PROGRAM

The seat belts are equipped with dual locking mechanisms; a webbing sensor lock and a G-sensor lock. A pawl spring may have been improperly installed by the seat belt manufacturer, which could affect the webbing sensor lock performance. However, the G-sensor lock performance is not affected by this condition; and as a result, the vehicle maintains FMVSS compliance through the use of the G-sensor locking mechanism.

WHAT SUBARU WILL DO

In the interest of your continued satisfaction Subaru will replace the left and right rear lap-shoulder seat belt assemblies in your vehicle at no cost to you.

WHAT YOU SHOULD DO

Please contact your Subaru retailer (dealer) for an appointment to have this repair performed, free of charge.

HOW LONG WILL THE REPAIR TAKE?

The actual time to perform this repair is less than one hour. However, it may be necessary to leave your vehicle for a longer period of time on the day of your scheduled appointment to allow your Subaru retailer flexibility in scheduling.

CHANGED YOUR ADDRESS OR SOLD YOUR SUBARU?

If you have moved or sold your vehicle, please update this information online at www.subaru.com, select 'Customer Support,' then select 'Address Update' or 'Ownership Update' from the drop-down menu.

IF YOU HAVE PREVIOUSLY PAID FOR A REPAIR

If you have already paid for repairs associated with this coverage, you may be eligible for reimbursement. Reimbursement consideration will be based on the amount an authorized Subaru retailer in your area would charge for the same repair.

Continued...

Please send the original service repair order, which has the name of the repair facility, date of repair, mileage at the time of repair, complete 17-digit vehicle identification number (VIN), and your name, with correct mailing address and telephone number to the address listed below.

**Subaru of America, Inc.
Customer Advocacy Department, Attention: WRA-20 Service Program
P.O. Box 9103, Camden, NJ 08101-9877**

Please send original receipts only and retain a photocopy for your records. Please be assured that we will attempt to process your reimbursement request as quickly as possible, but it may take up to 60 days for this process to be completed.

IF YOU NEED FURTHER ASSISTANCE:

To locate the nearest Subaru retailer, you can access our website at www.subaru.com and select 'Find a Retailer.'

For additional information, please go to: <http://www.wra20.service-campaign.com>.

If you need additional assistance, please contact us directly:

- By e-mail: Go to www.subaru.com and select "Contact Us"
- By telephone: 1-844-373-6614
Monday through Friday between 8:00 a.m. and 7:00 p.m. ET
- By U.S. Postal mail: Write us at Subaru of America, Inc.
Attn: Customer Advocacy Department
P.O. Box 9103, Camden, NJ 08101-9877

Please contact us immediately if the Subaru retailer fails or is unable to make the necessary repairs free of charge.

Your continued satisfaction with your Subaru is important to us. Please understand that we have taken this action in the interest of your vehicle's proper operation. We sincerely apologize for any inconvenience this matter may cause and urge you to schedule an appointment as soon possible.

Sincerely,
Subaru of America, Inc.

***Notice to Lessors:** Under Federal law the lessor of a vehicle who receives this letter must provide a copy of it to the vehicle lessee(s) within 10 business days from receipt. The lessor must also keep a record of the lessee(s) to whom this letter is sent, the date sent, and the applicable vehicle identification number (VIN). (For the purposes of this section, a lessor means a person or entity that in the last twelve months prior to the date of this notification has been the owner, as referenced on the vehicle's title, of any five or more leased vehicles. A leased vehicle is a vehicle leased to another person for a term of at least four months.)*

A subsidiary of SUBARU CORPORATION