

Safety Recall

N232421970 Seatbelt Pretensioner Recall 22V930 (N222383790)

Not Completed



Release Date: December 2023

Revision: 00

Attention: It is a violation of Federal law for a dealer to deliver a new motor vehicle or any new or used item of motor vehicle equipment (including a tire) covered by this notification under a sale or lease until the defect or noncompliance is remedied.

All involved vehicles that are in dealer inventory must be held and not delivered to customers, dealer traded, or used for demonstration purposes until the repair contained in this bulletin has been performed on the vehicle.

This recall must only be completed by Chevrolet EV certified dealers who have met all Bolt field action-specific training, tool and equipment requirements, and repairs must be performed by a technician who has successfully completed the required training.

For Canadian Dealers: Only Chevrolet Dealers who have signed the Chevrolet Electric Models Agreement and have met all the Chevrolet Bolt EV specific training, tools, and equipment requirements are eligible to complete the repair. Any Dealer unsure of their eligibility status should immediately review with their District Service Manager.

Make	Model	Model Year		RPO	Description
		From	To		
Chevrolet	Bolt EV	2020	2023		

Involved vehicles are marked "Open" on the Investigate Vehicle History screen in GM Global Warranty Management system. This site should always be checked to confirm vehicle involvement prior to beginning any required inspections and/or repairs.

Condition	General Motors has decided that a defect which relates to motor vehicle safety may exist in certain 2020 – 2023 model year Chevrolet Bolt EV vehicles that were included in GM recall 22V930 (N222383790). The GM dealership that serviced these vehicles in connection with GM recall 22V930 (N222383790) may not have performed the recall remedy procedure. If the recall remedy was not performed, and a crash occurs that causes the seatbelt pretensioner to deploy, a fire may develop in the area near the B-pillar, which may increase the risk of injury.
Correction	Dealers will inspect left and right front seatbelt pretensioners and, if necessary, install metal foil at the carpet near the pretensioner exhaust.

Parts

Locally sourced foil tape is required for this repair.

Warranty Information

Labor Operation	Description	Labor Time	Trans. Type	Net Item
9107102	Inspect ONLY – No further action required	0.8	ZFAT	N/A
9107103**	Install Foil Tape (includes inspection)	1.1	ZFAT	*

* The amount identified in "Net Item" should represent the actual sum total of the current GMCCA Dealer net price for 2.5" X 4.0 Mil aluminum foil tape meeting UL Spec 181A-P needed to perform the required repairs, not to exceed \$2.00 USD, \$6.88 CAD, plus applicable Mark-Up or Landed Cost (for Export). This is a locally sourced supply, do not order from GMCCA.

** Please submit a Field Product Report (FPR) in addition to completing this field action.

Service Procedure

Important: The following procedure requires the use of 2.5" X 4.0 Mil aluminum foil tape meeting UL Spec 181A-P. 3-M PN #3340 and Nashua #324A meet this specification. One of these products, or an equivalent must be used in this procedure. The equivalent material must meet the following specifications:

- Base Material: Aluminum Foil Tape
- Foil Thickness: 2 Mil thick foil (total tape thickness including adhesive will be approximately 3.4-4.5 Mil)
- Adhesive Type: Acrylic
- Temperature working range: -25°C to 125°C (-13°F to 257°F)
- Backing: Liner Backing Preferred for installation (Not required, should be discarded)

Safety Recall

N232421970 Seatbelt Pretensioner Recall 22V930 (N222383790)

Not Completed

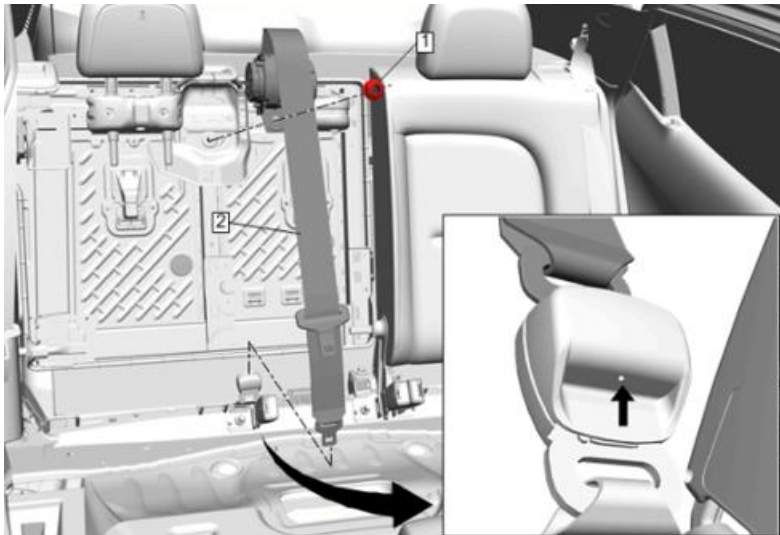

4585993

1. Push pin in the slot on mini-buckle to disengage the rear center seat belt retractor from the rear center seat belt buckle.

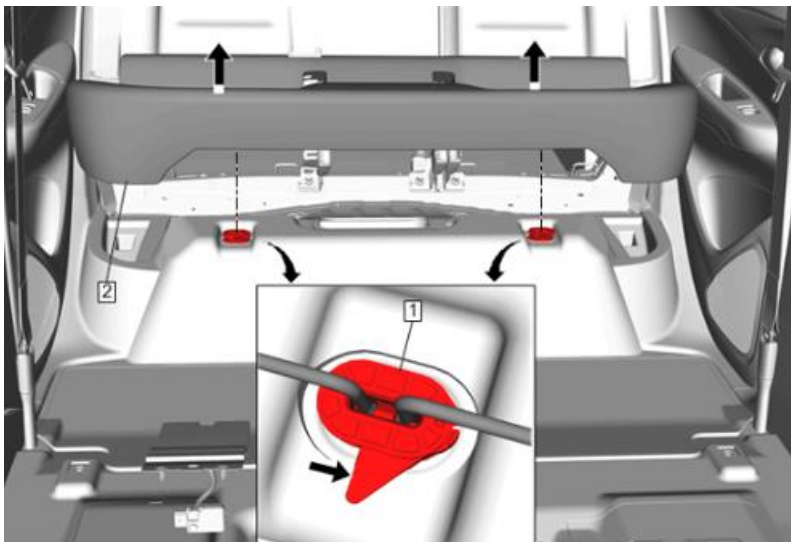

4537958

2. Release the 2 cushion clip tabs (1).
3. If equipped, disconnect the electrical connectors.
4. Pull up on the front of the Rear Seat Cushion (2) and lift out of the vehicle.

Safety Recall

N232421970 Seatbelt Pretensioner Recall 22V930 (N222383790)

Not Completed

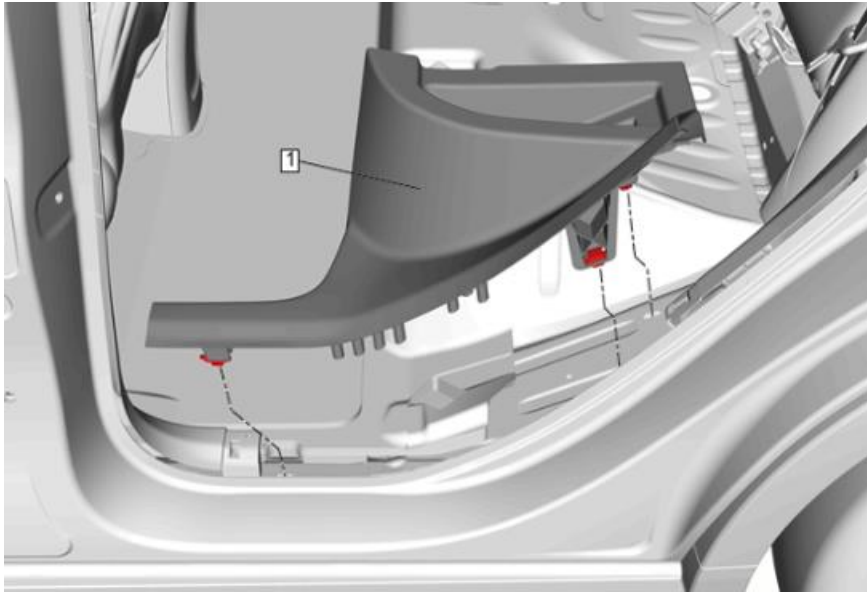

4552179

5. Starting at the front of the Rear Side Door Sill Garnish Molding (1), pull upward at the B-Pillar Joint to disengage the Rear Side Door Sill Garnish Molding (1) on both sides of the vehicle.
6. Work your way rearward disengaging all of the Rear Side Door Sill Garnish Molding clips then pull forward to disengage from the C-pillar lower on both sides of the vehicle.
7. Remove the Rear Side Door Sill Garnish Molding (1) on both sides of the vehicle.



4540195

8. Using a flat bladed plastic trim tool, remove the Instrument Panel Outer Trim Cover – Left Side (1).
9. Using a flat bladed plastic trim tool, remove the Instrument Panel Outer Trim Cover – Right Side (2).

Safety Recall

N232421970 Seatbelt Pretensioner Recall 22V930 (N222383790)
Not Completed

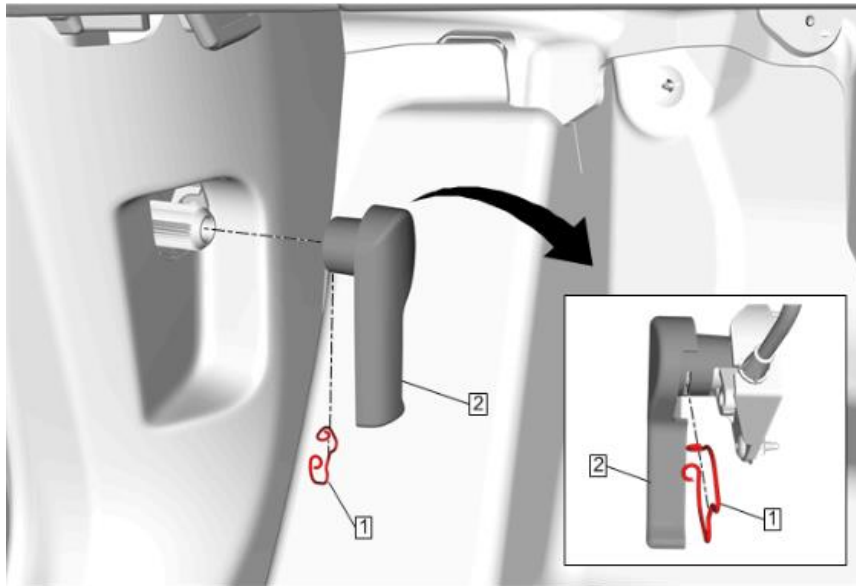

4532557

10. Pull down on the clip (1) to remove from the Hood Primary Latch Release Cable Handle (2).
11. Remove the Hood Primary Latch Release Cable Handle (2).

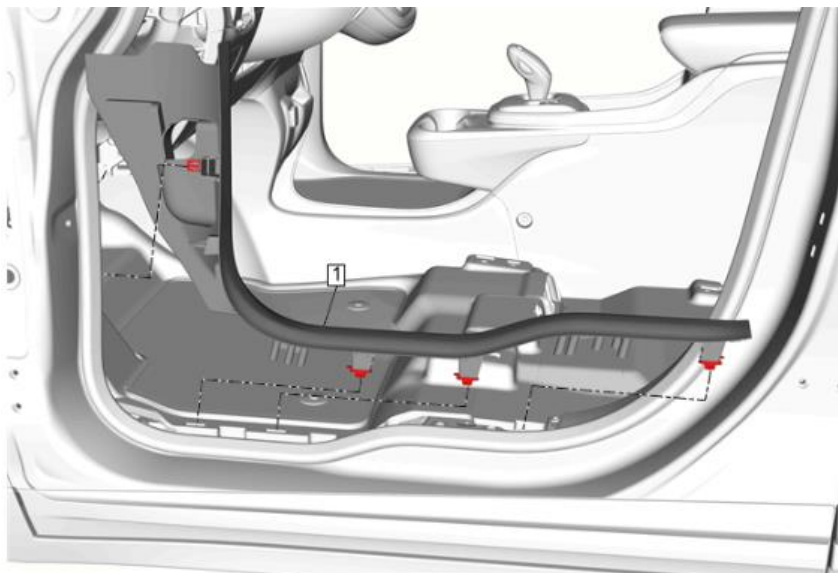

4552175

12. Starting at the rear of the Front Side Door Sill Garnish Molding (1), pull upward at the B-Pillar joint to disengage on both sides of the vehicle.
13. Work your way forward disengaging all of the Front Side Door Sill Garnish Molding clips then pull rearward to disengage the clip on the forward vertical wall.
14. Remove both of the Front Side Door Sill Garnish Moldings (1).
15. Move both front seats to the full forward position.

Safety Recall

N232421970 Seatbelt Pretensioner Recall 22V930 (N222383790)

Not Completed

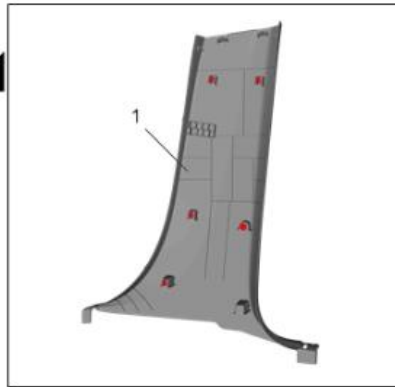
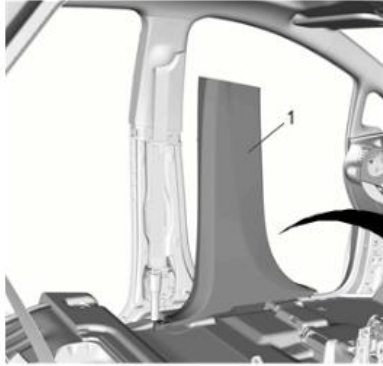

4552180

16. Pull the Center Pillar Lower Trim Panel (1) inward and upward to disengage the retainers on both sides of the vehicle.
17. Remove the Center Pillar Lower Trim Panel (1) on both sides of the vehicle.



6218989

18. Pull the carpet back around the seat belt pretensioner to expose the insulation on the passenger's side of the vehicle.

Safety Recall

N232421970 Seatbelt Pretensioner Recall 22V930 (N222383790)
Not Completed



6219024

Note: If the foil tape is NOT installed, submit a Field Product Report (FPR) in addition to completing this field action.

Note: The inspection MUST be completed on BOTH sides of the vehicle.

19. Inspect the carpet to see if foil tape is installed as described in this procedure, see above.

- If the foil tape is installed, proceed to step 26.
- If the foil tape is NOT installed, complete the following and proceed to step 20.

For US and CA Dealers - Submit a Field Product Report (FPR) and Pictures using the Field Product Reporter App found in the Certified Service Mobile Tools (reference TSB 02-00-89-002). Be sure to include the following information:

- Complete Dealer Information.
- Enter VIN and Mileage.
- For Condition enter: Seatbelt Pretensioner Fire.
- For Cause enter: NA.
- For Correction enter: Safety Recall N232421970.
- Important: Include pictures of the carpet/insulation without the tape installed. If both sides do NOT have the foil tape installed, please submit additional pictures for EACH side. Please make sure the pictures are in focus.

20. Cut insulation to be the same dimension as the existing hole for the cable (25 mm, 1 inch) as shown above.



5443038

Important: If 2.5" width tape is not available and narrower tape must be used, use two layers of the narrower tape overlapped on top of each other to create a 2.5" wide section of material. THIS MUST BE DONE ON THE BENCH

Safety Recall

N232421970 Seatbelt Pretensioner Recall 22V930 (N222383790)

Not Completed



BEFORE THE MATERIAL IS INSTALLED ON THE VEHICLE. ENSURE THE LAYERS OF TAPE ARE FULLY ADHERED TO EACH OTHER WITH NO GAPS before it is installed on the vehicle.

Note: While handling the foil tape, leave the paper liner on the tape and peel it off as the tape is applied to the surface.

21. Prepare two 150 mm (6 in) pieces of 3-M PN 3340 foil tape of an equivalent 2.5" X 4.0 Mil aluminum foil tape meeting UL Spec 181A-P.

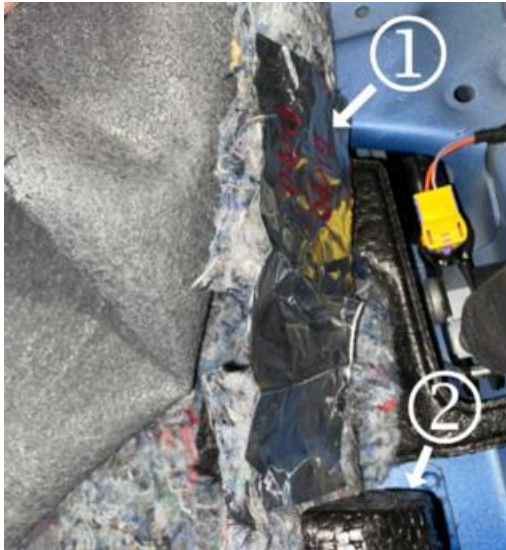

6219007

22. Place one of the pieces of foil tape (1) along the bottom of the insulation starting from the foam block (2) and going forward lining up with the edge of the insulation, as shown above.



6219020

23. Place the second piece of foil tape on top of the insulation lining it up with bottom piece of tape leaving about half the width of the tape hanging off the edge of the insulation.
24. Carefully fold the tape over the edge of the insulation and ensure it fully adheres to the bottom piece of tape as shown above.

Safety Recall

N232421970 Seatbelt Pretensioner Recall 22V930 (N222383790)
Not Completed



6219024

25. Cut a slit lining up with the seat belt pretensioner in both pieces of tape to allow the insulation and tape to fit around the pretensioner as shown above.
 26. Reinstall the insulation into its original location.
 27. Fold carpet back into place.
- Note:** If the foil tape is NOT installed on BOTH sides of the vehicle, submit BOTH sides on one FPR.
28. Repeat steps 18 through 27 on the driver's side of the vehicle.

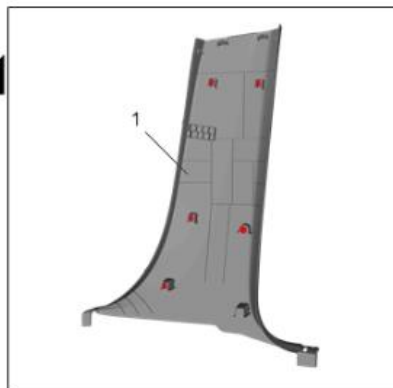
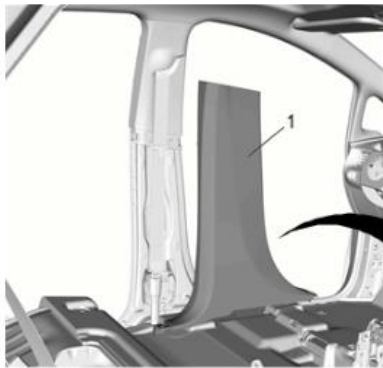

4552180

29. Install the Center Pillar Lower Trim Panel (1) on both sides of the vehicle.

Safety Recall

N232421970 Seatbelt Pretensioner Recall 22V930 (N222383790)

Not Completed

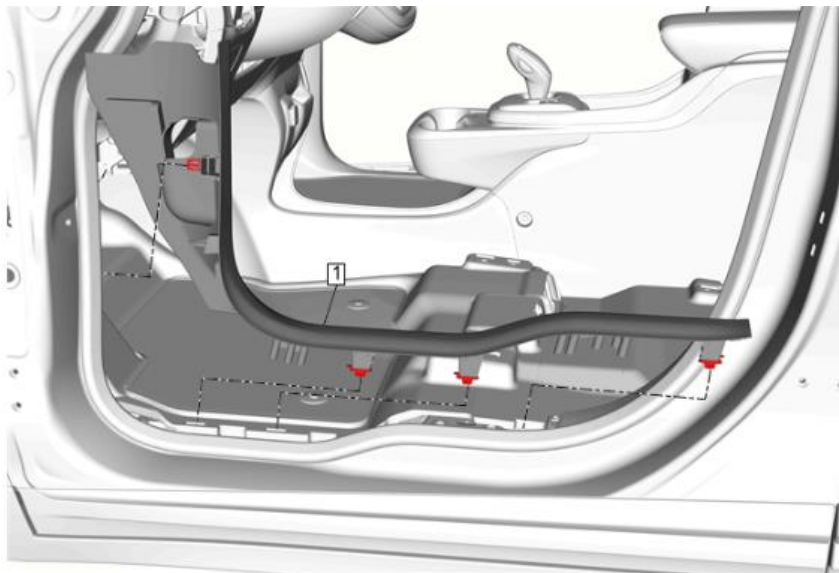

4552175

30. Install the Front Side Door Sill Garnish Molding (1) on both sides of the vehicle.

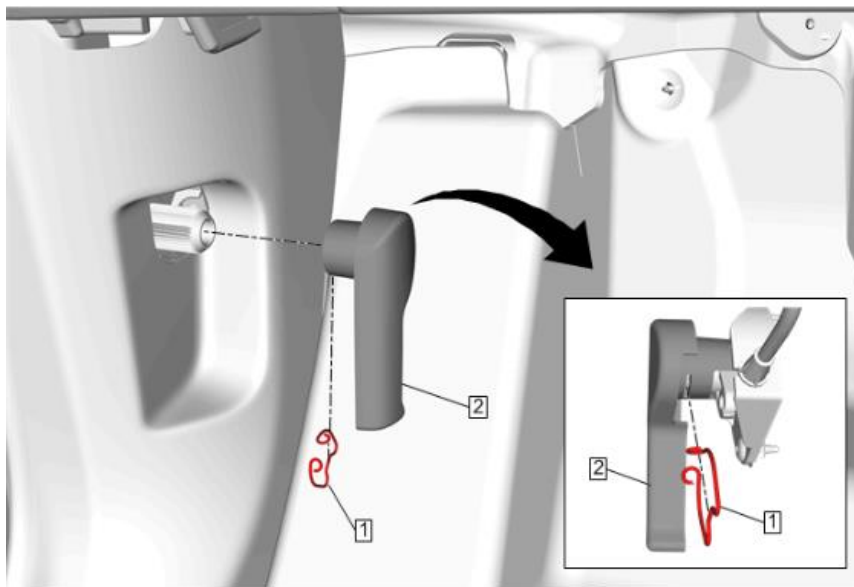

4532557

31. Install the Hood Primary Latch Release Cable Handle (2).

32. Install the clip (1).

Safety Recall

N232421970 Seatbelt Pretensioner Recall 22V930 (N222383790)
Not Completed



4540195

33. Install the Instrument Panel Outer Trim Cover – Left Side (1).
34. Install the Instrument Panel Outer Trim Cover – Right Side (2).

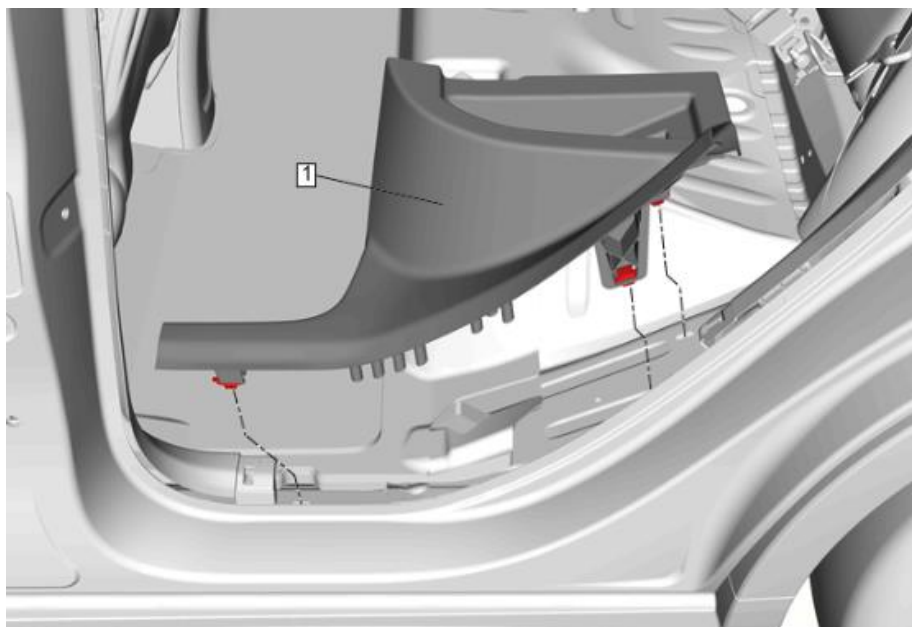

4552179

35. Install the Rear Side Door Sill Garnish Molding on both sides of the vehicle.

Safety Recall

N232421970 Seatbelt Pretensioner Recall 22V930 (N222383790)
Not Completed

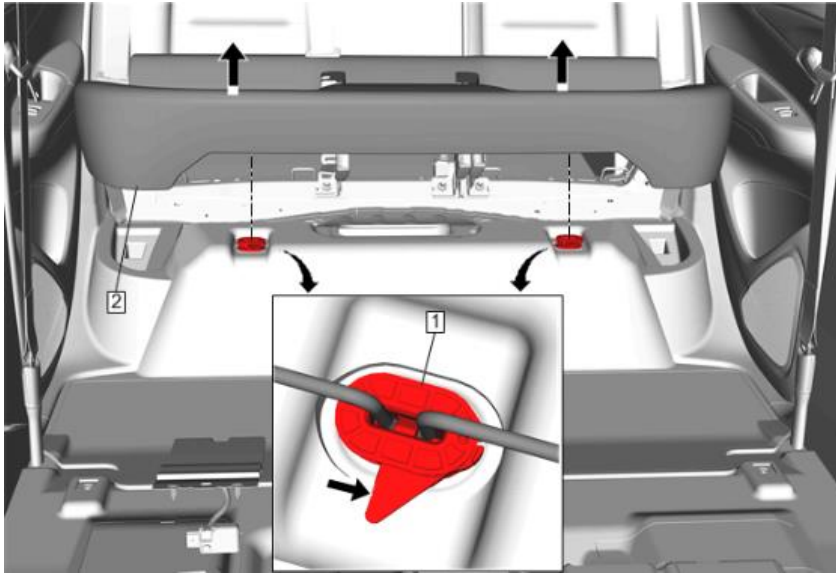

4537958

36. If equipped, connect the electrical connectors.

37. Install the Rear Seat Cushion (2).

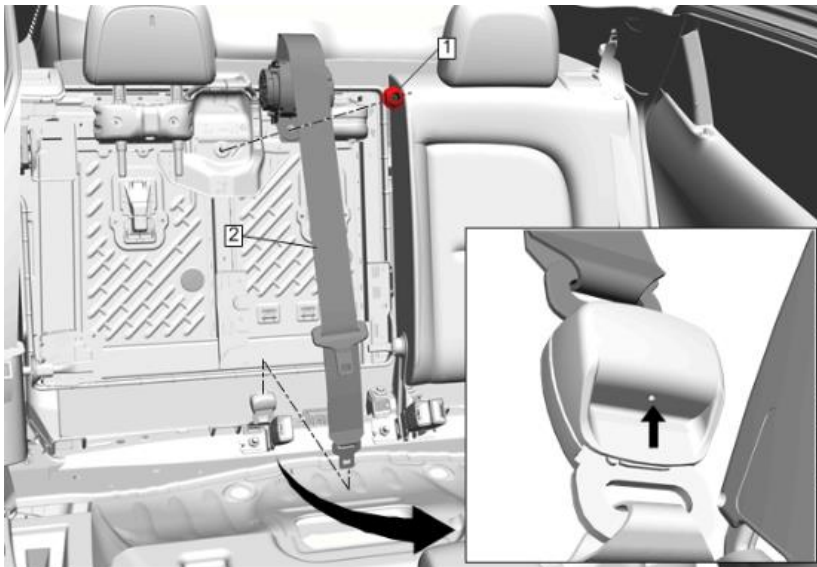

4585993

38. Reinstall the mini-buckle.

Dealer Responsibility – For USA & Export (USA States, Territories, and Possessions)

It is a violation of Federal law for a dealer to deliver a new motor vehicle or any new or used item of motor vehicle equipment (including a tire) covered by this notification under a sale or lease until the defect or noncompliance is remedied.

The US National Traffic and Motor Vehicle Safety Act provides that each vehicle that is subject to a recall of this type must be adequately repaired within a reasonable time after the customer has tendered it for repair. A failure to repair within sixty days after tender of a vehicle is prima facie evidence of failure to repair within a reasonable time. If the condition is not adequately repaired within a reasonable time, the customer may be entitled to an identical or reasonably equivalent vehicle at no charge or to a refund of the purchase price less a reasonable allowance for depreciation. To avoid having to provide these burdensome remedies, every effort must be made to promptly schedule an appointment with each customer and to repair their vehicle as soon as possible. In the recall notification letters, customers are told how to contact the US National Highway Traffic Safety Administration if the recall is not completed within a reasonable time.

Safety Recall

N232421970 Seatbelt Pretensioner Recall 22V930 (N222383790)

Not Completed



Dealer Responsibility – All

All new, used, GM Certified Pre-Owned (CPO), courtesy transportation vehicles, dealer shuttle vehicles, CarBravo, etc. in dealers' possession and subject to this recall must be held and inspected/repaired per the service procedure of this bulletin before customers take possession of these vehicles. Involved vehicles must be held and not delivered to customers, dealer-traded, released to auction, used for demonstration, or any other purpose.

All GM Certified Pre-Owned (CPO) vehicles currently in the dealers' inventory within the SHIFT Digital system will be de-certified and must be held and remedied per the service procedure in this bulletin. Upon submitting an accepted/paid warranty transaction in the Global Warranty Management (GWM) system, the vehicle can be re-certified for sale within the SHIFT Digital system, or once again be used in the Courtesy Transportation Program.

Dealers are to service all vehicles subject to this recall at no charge to customers, regardless of mileage, age of vehicle, or ownership, from this time forward.

Customers who have recently purchased vehicles sold from your vehicle inventory, and for which there is no customer information indicated on the dealer listing, are to be contacted by the dealer. Arrangements are to be made to make the required correction according to the instructions contained in this bulletin. Recall follow-up cards should not be used for this purpose, since the customer may not as yet have received the notification letter.

In summary, whenever a vehicle subject to this recall enters your vehicle inventory you must take the steps necessary to ensure the program correction has been made before selling the vehicle. In addition, for vehicles entering your facility for service, you are required to ensure the customer is aware of the open recall and make every reasonable effort to implement the program correction as set forth in this bulletin prior to releasing the vehicle.

Dealer Reports – For USA & Export

For dealers with involved vehicles, a listing has been prepared and will be available through GM GlobalConnect Maxis Field Action Reports or sent directly to export dealers. The Inventory tab of the dealer reports will contain VINs that apply to this recall. This information is intended to assist dealers with the **PROMPT COMPLETION** of these vehicles. The Customer In-Service tab will contain customer names and addresses from Motor Vehicle Registration Records. The use of such motor vehicle registration data for any purpose other than follow-up necessary to complete this recall may be a violation of law in several states.

Courtesy Transportation – For USA & Canada

Courtesy transportation is available for customers whose vehicles are involved in a product program and still within the warranty coverage period. See General Motors Service Policies and Procedures Manual for courtesy transportation program details.

Customer Notification

USA & Canada - General Motors will notify customers of this recall on their vehicle.

GM bulletins are intended for use by professional technicians, NOT a "do-it-yourselfer". They are written to inform these technicians of conditions that may occur on some vehicles, or to provide information that could assist in the proper service of a vehicle. Properly trained technicians have the tools, equipment, safety instructions, and know-how to do a job properly and safely. If a condition is described, DO NOT assume that the bulletin applies to your vehicle, or that your vehicle will have that condition. See your dealer for information on whether your vehicle may benefit from the information.



We Support
Voluntary Technician
Certification