

SAFETY RECALL
NORTH AMERICA
Malfunctioning SCCM



Reference: B2A / NHTSA 23V-799

FCA US LLC



RAM

- Remedy available for
- 2023-2024 (D2) RAM 3500 Pickup
- 2023-2024 (DD) RAM 3500 Cab/Chassis
- 2023 (DF) RAM 3500 10K LB. Cab/Chassis
- 2023-2024 (DJ) RAM 2500 Pickup
- 2023-2024 (DP) RAM 4500/5500 Cab Chassis
- 2023 (DS) RAM 1500 Pickup

Template Version 1.0

Revision	Edition	Detail
0	December 2023	Initial Version.

SYMPTOM DESCRIPTION

About 142,000 of the above vehicles may have been built with a steering column control module (SCCM) turn signal self-cancelling anti-jam component out of specification and/or an internal short circuit on the SCCM printed circuit board (PCB).

The conditions described above do not comply with Federal Motor Vehicle Safety Standard (FMVSS) No. 571.108. FMVSS 571.108 S9.1.1 requires that "The turn signal operating unit must be self-cancelling by steering wheel rotation and capable of cancellation by a manually operated control." The SCCM in the suspect vehicles may not allow the self-cancelling feature to function correctly. FMVSS 571.108 S6.1.5 requires that "...only those light sources intended for meeting lower beam photometrics are energized when the beam selector switch is in the lower beam position, and that only those light sources intended for meeting upper beam photometrics are energized when the beam selector switch is in the upper beam position." The SCCM in the suspect vehicles may cause the high beams to activate when using the turn signal, or the turn signal to activate when using the high beams.

A turn signal which remains active after a completed turn may cause surrounding drivers to misunderstand the intent to change vehicle direction. High beam activation when the turn signal switch is activated may result in reduced visibility of oncoming drivers. Either of these conditions may cause a vehicle crash without prior warning.

SCOPE

This recall applies only to the above vehicles.

NOTE: Some vehicles above may have been identified as not involved in this recall and therefore have been excluded from this recall.

IMPORTANT: Some of the involved vehicles may be in dealer new vehicle inventory. Federal law requires you to complete this recall service on these vehicles before retail delivery. Dealers should also consider this requirement to apply to used vehicle inventory and should perform this recall on vehicles in for service. Involved vehicles can be determined by using the VIP inquiry process.

IMPORTANT:

- Some of the involved vehicles may be in dealer new vehicle inventory. Federal law requires you to complete this recall service on these vehicles before retail delivery. Violation of this requirement by a dealer could result in a civil penalty of up to \$26,315 per vehicle.
- Some of the involved vehicles may be in dealer used vehicle inventory. Dealers should complete this recall service on these vehicles before retail delivery.
- Dealers should also perform this recall on vehicles in for service.

Involved vehicles can be determined by using the VIP inquiry process.

REPAIR TO BE PERFORMED

Verify the SCCM Julian date using wiTECH. Test the SCCM for proper function and flash the SCCM with diagnostic software. If the vehicle passes these steps, return it to the customer. If it fails any of these steps, replace the SCCM.

COMPLETION REPORTING / REIMBURSEMENT

Claims for vehicles that have been serviced must be submitted on the DealerCONNECT Claim Entry Screen located on the Service tab. Claims paid will be used by FCA to record recall service completions and provide dealer payments.

Use the following labor operation numbers and time allowances:

Labor Description	Number	Hrs
Inspect SCCM Julian Date and Perform Software Update (D2, DD, DF, DJ, DP Only)	08-B2-A1-82	0.4
Inspect SCCM Julian Date and Perform Software Update (DS Only)	08-B2-A1-83	0.3
Inspect SCCM Julian Date, Perform Software Update, and Perform Verification Routine (D2, DD, DF, DJ, and DP Only)	08-B2-A1-84	0.7
Inspect SCCM Julian Date, Perform Software Update, and Perform Verification Routine (DS Only)	08-B2-A1-85	0.6

Related Labor Description	Number	Hrs
Replace SCCM (D2, DD, DF, DJ, DP Only)	08-B2-A1-51	0.5
Replace SCCM (DS Only)	08-B2-A1-52	0.6

Labor Description	Number	Allowance
Floor Plan Reimbursement	95-95-95-97	Calculate See Below

Floor Plan Reimbursement represents the vehicle's average daily allowance (see table below) multiplied by the number of days the vehicle was in dealer inventory and not available for sale. This reimbursement is limited to the number of days from the date of the stop sale to the date that the remedy was made available. Note: If the vehicle was received by your dealership (KZX date) AFTER the stop sale date, you will use the KZX date instead of the stop sale date. For this Recall, the stop sale was initiated on **12/05/2023** and the remedy was made available on **12/09/2023**, therefore, the number of days cannot exceed **4** days.

Vehicle	Average Daily Allowance
2023 - 2024 D2	██████
2023 - 2024 DD	██████
2023 DF	██████
2023 - 2024 DJ	██████
2023 - 2024 DP	██████
2023 DS	██████

Add the cost of the recall parts package plus applicable dealer allowance to your claim.

NOTE: See the Warranty Administration Manual, Recall Claim Processing Section, for complete recall claim processing instructions.

PARTS INFORMATION

Any required parts **must** be ordered by STAR Center, once approved.

ONLY IF and AFTER this Service Procedure directs you to "Replace the SCCM," submit a STAR Case, select **"I will wait for STAR response"** including "B2A" in the **Customer Concern**, select **Body** as the **Primary System Affected**, attach a Vehicle Scan Report, request review and ordering of appropriate SCCM." The STAR Center agent will determine and order the correct SCCM for the submitted vehicle.

PARTS RETURN

No parts return required for this campaign.

Render the recalled part unusable and discard.

SPECIAL TOOLS

Number	Description	Picture
NPN	wiTECH MicroPod II / MDP	
NPN	Laptop Computer	
NPN	wiTECH Software	
10187	Remover Tool, Driver's Airbag	
C-4755	Trim Stick	
2050200100	Remover, Driver Air Bag	

DEALER NOTIFICATION

To view this notification on DealerCONNECT, select "Global Recall System" on the Service tab, then click on the description of this notification.

OWNER NOTIFICATION / SERVICE SCHEDULING

All involved vehicle owners known to FCA are being notified of the service requirement by first class mail. They are requested to schedule appointments for this service with their dealers. A generic copy of the owner letter is attached.

VEHICLE LISTS, GLOBAL RECALL SYSTEM, VIP AND DEALER FOLLOW UP

All involved vehicles have been entered into the DealerCONNECT Global Recall System (GRS) and Vehicle Information Plus (VIP) for dealer inquiry as needed.

GRS provides involved dealers with an updated VIN list of their incomplete vehicles. The owner's name, address and phone number are listed if known. Completed vehicles are removed from GRS within several days of repair claim submission.

To use this system, click on the "Service" tab and then click on "Global Recall System." Your dealer's VIN list for each recall displayed can be sorted by those vehicles that were unsold at recall launch, those with a phone number, city, zip code, or VIN sequence.

Dealers must perform this repair on all unsold vehicles before retail delivery. Dealers should also use the VIN list to follow up with all owners to schedule appointments for this repair.

Recall VIN lists may contain confidential, restricted owner name and address information that was obtained from the Department of Motor Vehicles of various states. Use of this information is permitted for this recall only and is strictly prohibited from all other use.

ADDITIONAL INFORMATION

If you have any questions or need assistance in completing this action, please contact your Service and Parts District Manager.

Customer Services / Field Operations
FCA US LLC.

SERVICE PROCEDURE - DIAGNOSIS

A. Check SCCM Julian Date

NOTE: The wiTECH scan tool must be used to perform this recall. The wiTECH software is required to be at the latest release level before performing this procedure.

1. Open the hood. Install a battery charger and verify that the charging rate provides 13.0 to 13.5 volts. Do not allow the charger to time out during the flash process. Set the battery charger timer (if so equipped) to continuous charge.

NOTE: Use an accurate stand-alone voltmeter. The battery charger volt meter may not be sufficiently accurate. Voltages outside of the specified range will cause an unsuccessful flash. If voltage reading is too high, apply an electrical load by activating the park or headlamps and/or HVAC blower motor to lower the voltage.

2. Connect the wiTECH MDP to the vehicle data link connector.
3. Place the ignition in the “**RUN**” position.
4. Open the wiTECH 2.0 website.
5. Enter your “**User id**” and “**Password**” and your “**Dealer Code**”, then select “**Sign In**” at the bottom of the screen. Click “**Accept**”.
6. From the “**Vehicle Selection**” screen, select the vehicle to be updated.
7. From the left column in the “**Analysis**” section, select “**Reports**”, select “**Vehicle Scan Report**”.

8. Find the serial number for the **SCCM** in the **Vehicle Scan Report**. Heavy Duty trucks read digits 7-10, DS trucks read digits 5-8 (Figure 1).

Top Image (DS Trucks):

ECU NAME	BUS TYPE	FLASH PART NUMBER	CURRENT VIN	ORIGINAL VIN	PART NUMBER	COUNTRY CODE	HARDWARE VERSION	SOFTWARE VERSION	IDENT	SERIAL NUMBER	CVNS
SCCM Steering Column Control Module	CAN-C	6853899A2	3C6RR7L7BPG000169	3C6RR7L7BPG000169	6853899A2	USA	16.12.00	16.1F.00	4101	370122210035	

Bottom Image (HD Trucks):

ECU NAME	BUS TYPE	FLASH PART NUMBER	CURRENT VIN	ORIGINAL VIN	PART NUMBER	COUNTRY CODE	HARDWARE VERSION	SOFTWARE VERSION	IDENT	SERIAL NUMBER	CVNS
SCCM Steering Column Control Module	CAN-C	68538702F	3C6URSL2JPG000032	3C6URSL2JPG000032	68538702F	USA	16.11.00	16.2A.00	4102	003704229118	

Figure 1 – Scan Report Examples – Top Image is DS Trucks, Bottom Image is HD Trucks

Strictly respect STELLANTIS Group safety, cleanliness, and environmental instructions for any vehicle service. Document exclusively reserved for dealer information. Internal distribution to be ensured by dealer. Reproduction forbidden without the written agreement of STELLANTIS Group. (C) 2023 STELLANTIS Group. All Rights Reserved (dit)

9. Read the serial number Julian date code as shown above. **Date code 3150 or before?**

- **YES** – Continue with diagnosis in **B. Fault Code Check**.
- **NO** – Perform the software update in **D. wiTECH Diagnostic Testing, steps 43-50 and 54-56 ONLY**.

B. Fault Code Check

10. Using the wiTECH tool, check for SCCM fault codes B17E3-92 or B23A1-2A. Is either code present?

- **YES** – Replace the SCCM. See **E - H Remove and Install SCCM** steps.
- **NO** – Continue the diagnosis in **C. Functional Check**.

C. Functional Check

11. Turn the headlamps **ON** (do not use the AUTO position).

12. Check that the Multifunction Lever is in the nominal position (turn signals **OFF**/Low Beam position)

13. Verify that the High Beam Indicator/Lamps is **OFF**. Verify that the LH Turn Signal is **OFF**.

- If High Beam Indicator or High Beam Lamps are **ON**, replace the SCCM. See **E - H Remove and Install SCCM** steps.
- If LH Turn Signal is **ON**, replace the SCCM. See **E - H Remove and Install SCCM** steps.
- If the High Beam Indicator, High Beam Lamps and LH Turn Signal all remain **OFF**, continue with Step 14.

14. Check that the Multifunction Lever is in the nominal position (turn signals **OFF**/Low Beam position).

15. Turn the headlamps to the **OFF** position.

16. Ensure that the steering wheel is centered.

17. Engage the Multifunction Lever in the LH Turn **latched** position for 5 seconds.

18. Verify that the high beam indicator and lamps are **OFF**. Are the indicator and lamps off?

- **YES** - Continue with **Step 19**.
- **NO** - Replace the SCCM. See **E - H Remove and Install SCCM** steps.

19. Disengage the LH turn signal. Ensure that the Multifunction Lever is in the nominal position.

20. Pull the Multifunction Lever to the headlamp Flash to Pass position for 5 seconds.

21. Verify that the LH Turn Signals are **OFF**. Turn signals off?
 - **YES** - Continue with **Step 22**.
 - **NO** - Replace the SCCM. See **E - H Remove and Install SCCM** steps.
22. Check that the Multifunction Lever is in the nominal position (turn signals **OFF**/Low Beam position).
23. Start the vehicle.
24. Engage the RH turn signal, indicating RH turn.
25. Turn the steering wheel 1/4 turn clockwise.
26. **As quickly and rapidly as possible**, return the steering wheel back to the "Center" position. Repeat the process 5 times, engaging the RH turn signal each time.
27. Verify that the turn signal cancels after every cycle. Turn signal cancelled?
 - **YES** - Continue with **Step 28**.
 - **NO** - Replace the SCCM. See **E - H Remove and Install SCCM** steps.
28. Engage the LH turn signal, indicating LH turn.
29. Turn the steering wheel 1/4 turn counterclockwise.
30. **As quickly and rapidly as possible**, return the steering wheel back to the "Center" position. Repeat the process 5 times, engaging the LH turn signal each time.
31. Verify that the turn signal cancels after every cycle. Turn signal cancelled?
 - **YES** - Continue with **Step 32**.
 - **NO** - Replace the SCCM. See **E - H Remove and Install SCCM** steps.
32. Push the Multifunction Lever to the forward latched position to engage the High Beam headlamps.
33. Engage RH turn signal, indicating RH turn.
34. Turn Steering Wheel 1/4 turn clockwise.
35. **As quickly and rapidly as possible**, return the steering wheel back to the "Center" position. Repeat the process 5 times, engaging the RH turn signal each time.
36. Verify that the turn signal cancels after every cycle. Turn signal cancelled?
 - **YES** - Continue with **Step 37**.
 - **NO** - Replace the SCCM. See **E - H Remove and Install SCCM** steps.
37. Keep the Multifunction Lever to the forward latched position to engage the High Beam headlamps.
38. Engage LH turn signal, indicating LH turn.

39. Turn Steering Wheel 1/4 turn counterclockwise.
40. **As quickly and rapidly as possible**, return the steering wheel back to the "Center" position. Repeat the process 5 times, engaging the LH turn signal each time.
41. Verify that the turn signal cancels after every cycle. Turn signal cancelled?
 - **YES** - Continue with **Step 42**.
 - **NO** - Replace the SCCM. See **E - H Remove and Install SCCM** steps.
42. Using the wiTECH tool, check again for SCCM fault codes B17E3-92 or B23A1-2A. Is either code present?
 - **YES** – Replace the SCCM. See **E - H Remove and Install SCCM** steps.
 - **NO** – Continue with **Step 43**.

D. wiTECH Diagnostic Testing

43. From the “**Action Items**” screen, select the “**Topology**” tab.
44. From the “**Topology**” tab, select the “**SCCM**” module icon.
45. From the “**Flash**” tab, compare the “**Current Electronic Control Unit (ECU) Part Number**” with the “**New ECU Part Number**” listed.
 - a. If the “**Current ECU part Number**” is the same as the “**New Part Number**”, proceed to **Step 50**.
 - b. If the “**Current ECU part Number**” is NOT the same as the “**New Part Number**”, continue with **Step 46**.
46. From the SCCM tab, select the SCCM flash part number. Read the flash special instructions page. Select “**OK**” to continue.
47. From the flash ECU agreement page, agree to terms by checking the box.
48. Select “**Flash ECU**” and then follow the wiTECH screen instructions to complete the flash.
49. Confirm the software is at the latest available calibration level.
50. Click “**View DTCs**”, select “**Clear All DTCs**”, click “**Continue**” and then click “**Close**”.
51. Check that the Multifunction Lever is in the nominal position (turn signals **OFF**/Low Beam position).

IMPORTANT: Multifunction Lever must not be moved during the diagnostic Subroutine as this could trigger a FALSE FAIL!
52. Run the “**SCCM Internal Short Circuit Diagnostic Check**” from the “**System Tests**” tab. Allow the routine to run for the full 10 minutes. A pass/fail message will appear when the test is complete.

SAFETY RECALL
NORTH AMERICA
Malfunctioning SCCM



Reference: B2A / NHTSA 23V-799

FCA US LLC

-
53. The **SCCM Internal Short Circuit Diagnostic Check** will provide pass/fail messages. Follow the wiTECH on-screen prompts.
- **PASS** - Proceed to Step 54.
 - **FAIL** - DTC B2225-92 set, replace the SCCM. **See E - H Remove and Install SCCM steps.**
54. Turn the ignition to the **"OFF"** position and then remove the wiTECH MDP device from the vehicle.
55. Remove the battery charger from the vehicle and then close the hood.
56. Return the vehicle to the customer.

SERVICE PROCEDURE - DS

E. Remove SCCM

WARNING: To avoid serious or fatal injury on vehicles equipped with airbags, disable the Supplemental Restraint System (SRS) before attempting any steering wheel, steering column, airbag, seat belt tensioner, impact sensor or instrument panel component diagnosis or service. Disconnect and isolate the battery negative (ground) cable, then wait two minutes for the system capacitor to discharge before performing further diagnosis or service. This is the only sure way to disable the SRS. Failure to take the proper precautions could result in accidental airbag deployment.

WARNING: To avoid serious or fatal injury, use extreme care to prevent any foreign material from entering the Driver AirBag (DAB), or becoming entrapped between the DAB cushion and the DAB trim cover. Failure to observe this warning could result in occupant injuries upon airbag deployment.

CAUTION: If the clockspring is not properly centered in relation to the Steering Angle Sensor (SAS), steering wheel, steering shaft and steering gear, it may be damaged or Diagnostic Trouble Codes (DTC) may be set in the SAS. Service replacement clocksprings are shipped pre-centered and with a locking pin installed. This locking pin should not be removed until the clockspring has been installed on the steering column.

1. Place the front wheels in the straight-ahead position.
2. Disconnect and isolate the negative battery cable. If equipped with an Intelligent Battery Sensor (IBS), disconnect the IBS connector first before disconnecting the negative battery cable.
3. Wait 2 minutes for capacitor discharge.
4. From below the steering column, remove the two outboard screws within the recess areas (2) that secure the upper shroud (1) to the lower shroud (3) (Figure 2).

NOTE: There are snap connections near the instrument cluster and between the shroud and the steering wheel that secure the upper and lower shroud.

5. Remove the upper shroud (1) by pushing gently inward and upward on both sides of the upper shroud above the parting line of the lower shroud to release the snap features that secure the two shroud halves to each other (Figure 2).
6. Release the steering column tilt lever and lower the column to its most downward position for easiest driver airbag removal access.

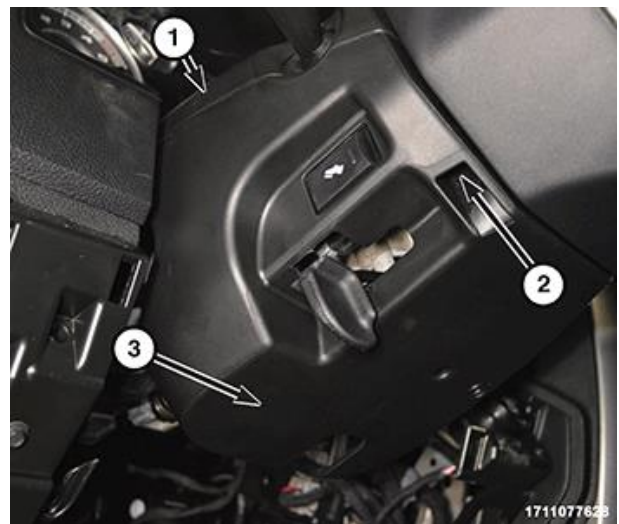
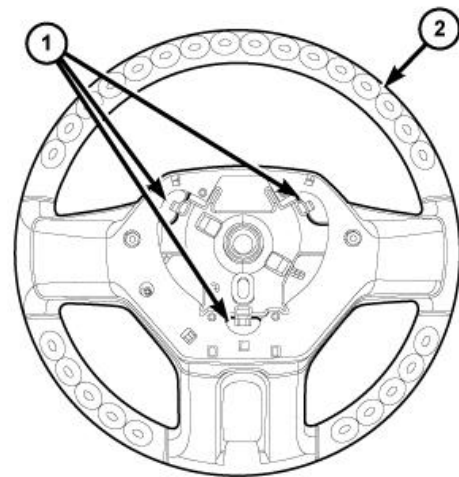

Figure 2 – Steering Column Upper Shroud

NOTE: It may be helpful to use a small mirror to aid visibility during the initial attempt to remove the Driver AirBag (DAB) from the steering wheel.

7. There are three airbag retainer access holes (1) on the instrument panel side of the hub of the steering wheel (2), located at the two o'clock, six o'clock and ten o'clock positions. The steering wheel must be rotated to bring each of these access holes up to the twelve o'clock position of the steering column one at a time for removal access (Figure 3).



2128157

Figure 3 – Airbag Retainer Access Holes

8. Insert the short blade (Tip A) of the DAB Removal Tool (Special Tool Number 10187) (1) or the blade of an equivalent prying tool into either of the upper (two o'clock or ten o'clock) access holes (3) of the steering wheel hub rear trim cover (2), being certain to place the blade of the tool on the inboard (steering wheel hub) side of the airbag snap retainer wire loop (Figure 4).

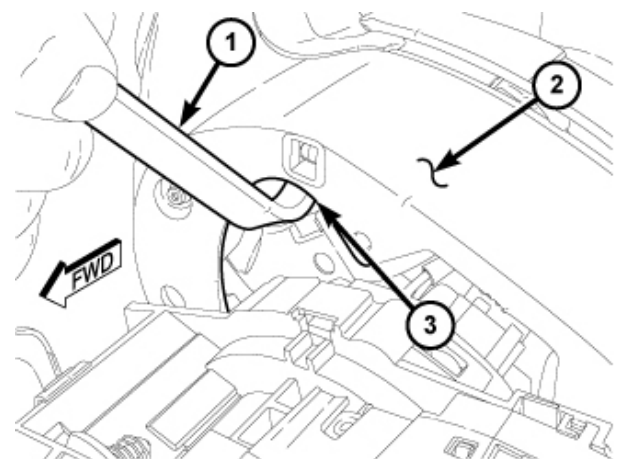

Figure 4 – DAB Removal Tool 10187

9. Push the handle of the tool downward for the blade to pry the snap retainer wire loop (3) upward far enough to disengage the loop from the hook of the steering wheel armature. At the same time, gently pull the DAB (1) away from the steering wheel (2) to prevent the retainer from snapping back into place over the hook once it is disengaged (Figure 5).
10. Repeat Steps 7 and 8 at the other upper (two o'clock or ten o'clock) access hole to disengage the other upper snap retainer wire loop.
11. Repeat Steps 7 and 8 at the lower (six o'clock) access hole to disengage the lower snap retainer wire loop. The lower snap retainer wire loop has a distinctive V-shape and must always be installed onto the six o'clock hook of the steering wheel armature.

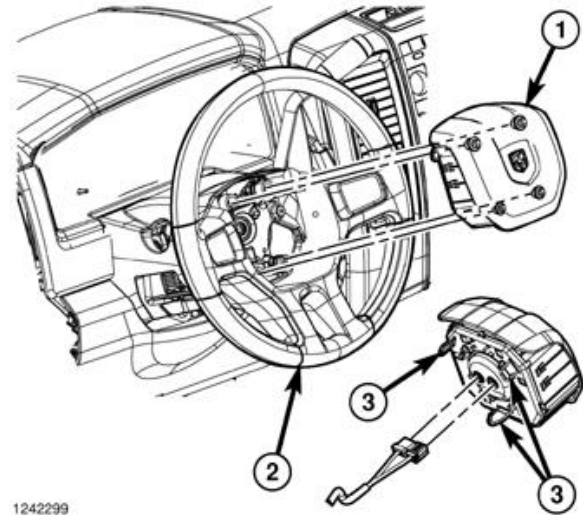

Figure 5 – Airbag Removal

12. Pull the DAB away from the steering wheel far enough to access and disengage the plastic push-in retainer (2) of the clockspring pigtail wire harness (1) from the locator hole (3) at the 12 o'clock position on the back of the airbag housing (Figure 6).

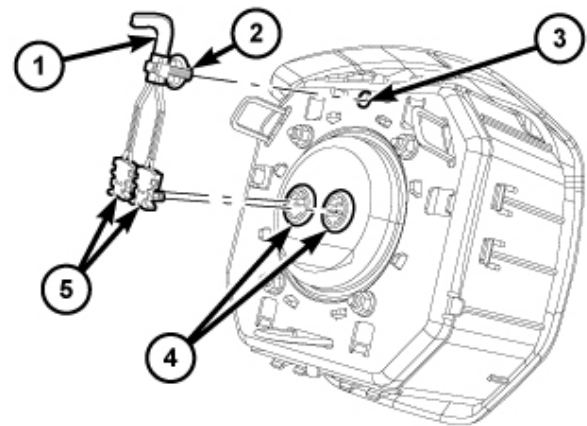
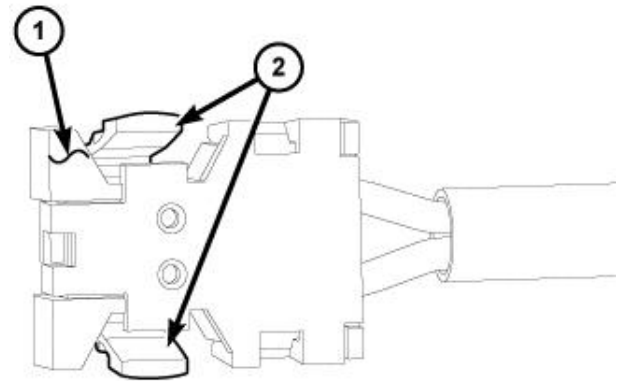

Figure 6 – Pigtail Wiring Harness Retainer

CAUTION: Do not pull on the clockspring pigtail wires or pry on the connector insulator to disengage the connector from the driver airbag inflator connector receptacle. Improper removal of these pigtail wires and their connector insulators can result in damage to the airbag circuits or connector insulators.

13. The clockspring DAB pigtail wire connector insulators (1) are secured by integral latches (2) to the airbag inflator connector receptacles, which are located on the back of the airbag housing. Pinch both latches firmly, then pull the insulators straight out from the airbag inflator to disconnect them from the connector receptacles (Figure 7).
14. Remove the DAB from the steering wheel
15. Remove the steering wheel bolt and **DISCARD**.



2128907

Figure 7 – Connector Insulator Latches

16. Disconnect the wire harness connectors (1) and (2) (Figure 8).
17. Remove the steering wheel.

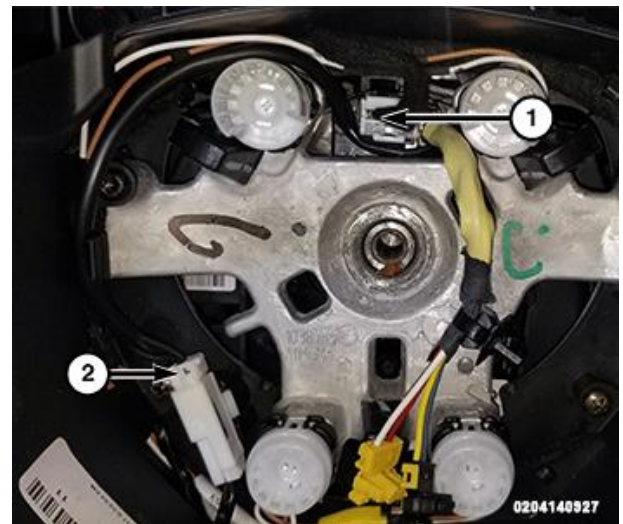

Figure 8 – Wire Harness Connectors

18. Using a trim stick C-4755 or equivalent, disengage the retainer clip that secures the hood release to the steering column opening cover, and remove the hood release handle from the cover (Figure 9).
19. Remove the two fasteners (2) that secure the bottom of the steering column opening cover (1) to the instrument panel (Figure 9).

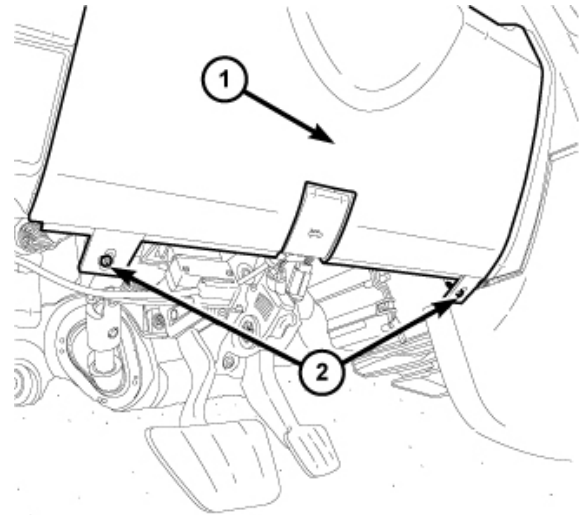
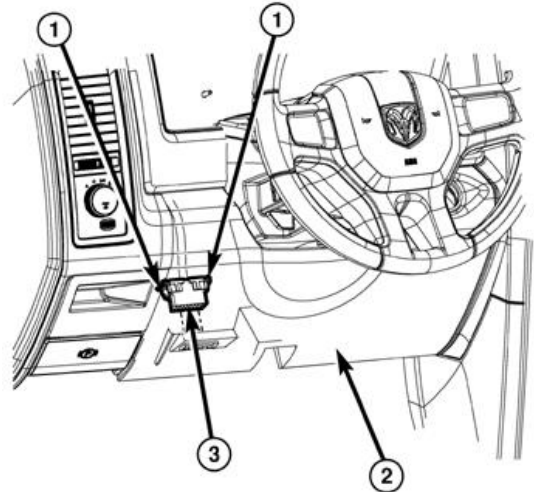

Figure 9 – Steering Column Opening Cover

20. Remove the Data Link Connector (3) from the steering column opening cover (2) by pressing in the tabs (1) and pushing the connector through the opening on the back side of the cover (Figure 10).



1423311

Figure 10 – Data Link Connector

SAFETY RECALL
NORTH AMERICA
Malfunctioning SCCM



Reference: B2A / NHTSA 23V-799

FCA US LLC

21. Using a trim stick C-4755 or equivalent, release the retainer clips that secure the steering column opening cover (1) to the instrument panel and remove the cover (Figure 11).
22. Disconnect necessary wire harness connectors.

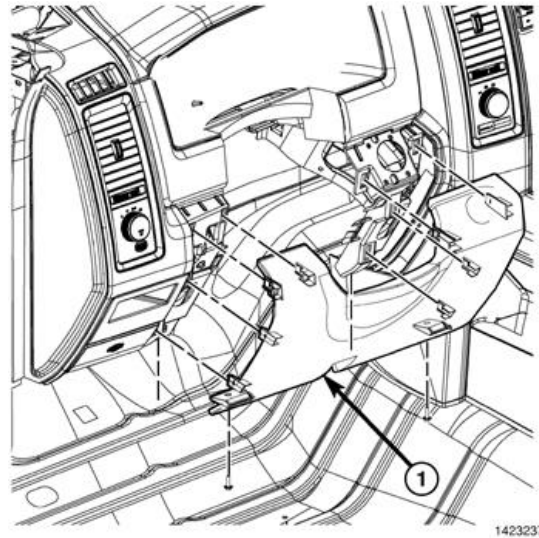

Figure 11 – Steering Column Opening Cover

23. Remove the lower shroud to column retaining screw (1) and carefully move the lower shroud over the steering column tilt lever and off the steering column (Figure 12).

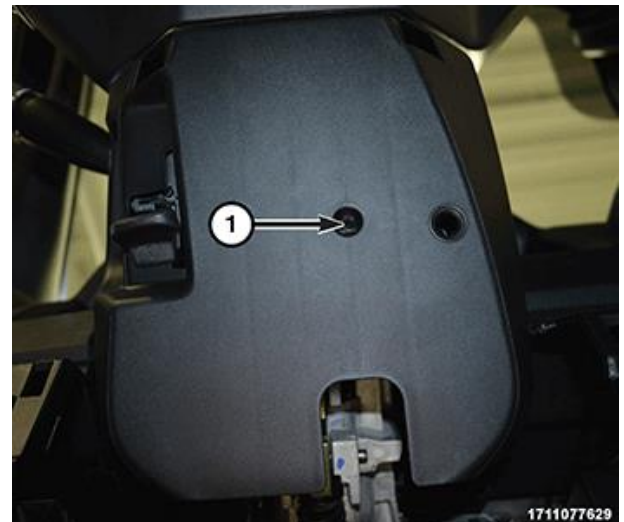

Figure 12 – Steering Column Lower Shroud

SAFETY RECALL
NORTH AMERICA
Malfunctioning SCCM



Reference: B2A / NHTSA 23V-799

FCA US LLC

24. Remove the screw (1) (Figure 13).

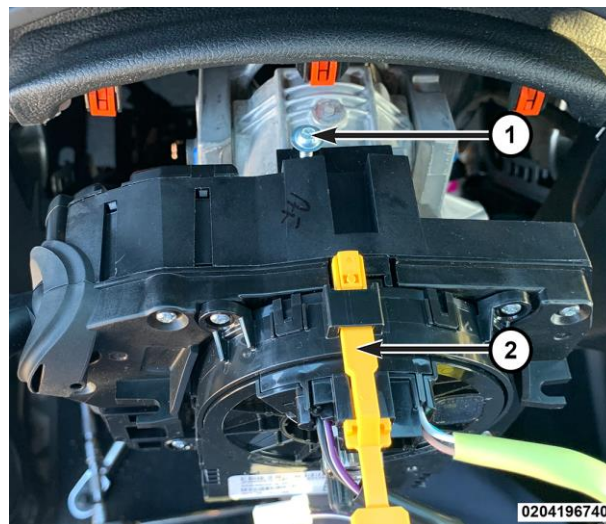

Figure 13 – SCCM Screw

25. Remove the screw (1) (Figure 14).

26. Pull the SCCM slightly away from the steering column and disconnect the pedal adjustment wire harness connector, if equipped.

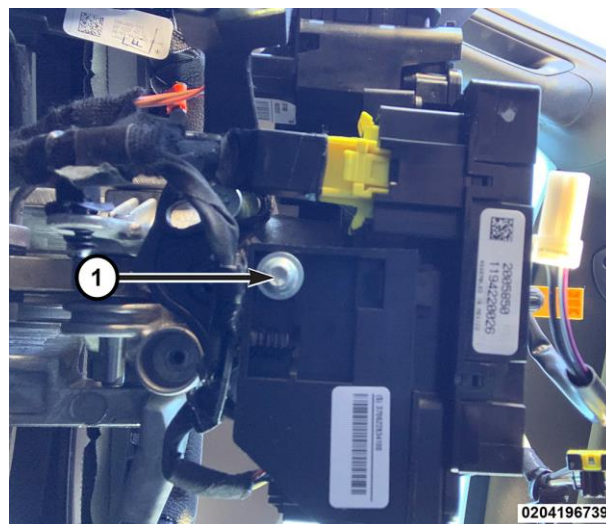

Figure 14 – SCCM Screw

SAFETY RECALL
NORTH AMERICA
Malfunctioning SCCM



Reference: B2A / NHTSA 23V-799

FCA US LLC

27. Remove the SCCM from the steering column (Figure 15).
28. Disengage the wire harness routing clip (1) (Figure 15).
29. Disconnect the wire harness connectors (2 & 3) (Figure 15).
30. Remove and DISCARD the SCCM from the vehicle.

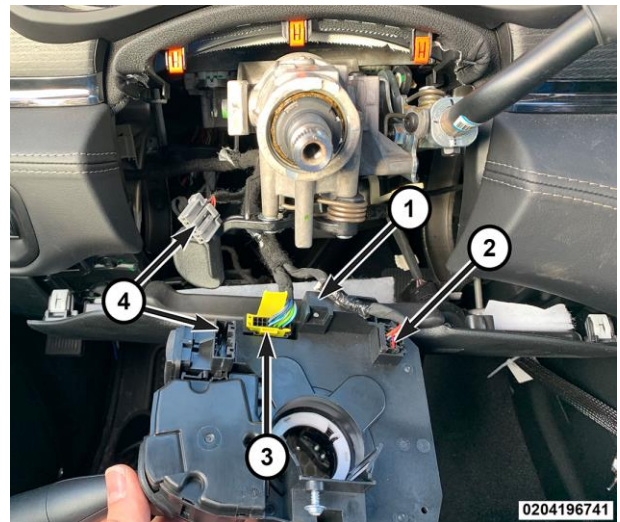

Figure 15 – SCCM Removal

F. Install SCCM

NOTE: The Steering Column Control Module (SCCM) centering can be verified by visually confirming the blue striped ribbon is present in the sight glass (Figure 16).

1. Connect the wire harness connectors (2&3) (Figure 15).
2. Secure the wire harness routing clip (1) (Figure 15).
3. While sliding the SCCM over the steering column connect the pedal adjustment wire harness connector, if equipped.
4. Install and securely tighten the screws (1) (Figures 13 & 14).
5. Remove the lock tab or any other device that is being used to secure the SCCM rotor to the SCCM case to maintain SCCM centering.

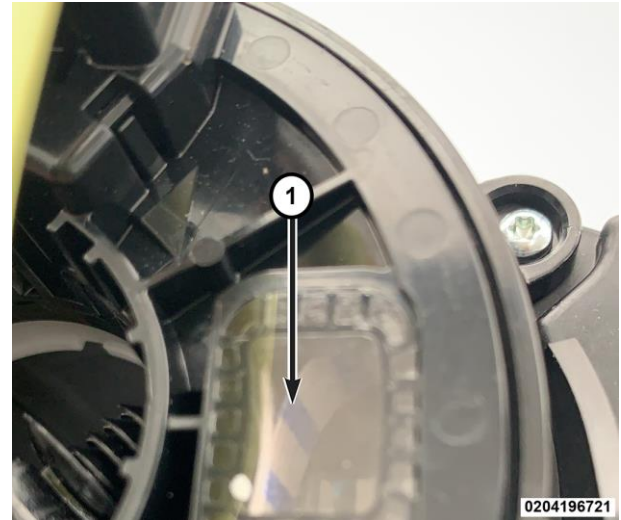

Figure 16 – Blue Stripe Ribbon

6. Install the lower shroud, shroud to column retaining screw (1) and tighten securely (Figure 12).

NOTE: If the vehicle is equipped with an automatic transmission, be certain to engage the gearshift lever boot into the opening in both shroud halves.

7. Lift the steering column opening cover into position. Connect necessary wire harness connectors.
8. Align the retainer clips that secure the steering column opening cover (1) to the instrument panel and install the cover (Figure 11).
9. Install the Data Link Connector (3) to the steering column opening cover (2) through the opening on the back side of the cover (Figure 10).
10. Install the two fasteners (2) that secure the bottom of the steering column opening cover (1) to the instrument panel and tighten securely (Figure 9).
11. Engage the retainer clip that secures the hood release to the steering column opening cover (Figure 9).

NOTE: Do not reuse the old steering wheel bolt (a new bolt must be used)

12. Align the steering column control module (SCCM) lug and install steering wheel to the column.

NOTE: Be certain that the steering wheel mounting bolt is tightened to the proper torque specification to ensure proper clockspring operation.

13. Install the **NEW** steering wheel bolt. Tighten the bolt to 61 N·m (45 ft. lbs.).
14. Connect the wire harness connectors (1) and (2) (Figure 8).

15. Position the Driver AirBag (DAB) close enough to the steering wheel to reconnect the two clockspring DAB pigtail wire (1) electrical connections (5) to the inflator connector receptacles (4) on the back of the airbag housing (Figure 6).
16. Reconnect the wire connectors to the airbag inflator connector receptacles by pressing straight in on the connector insulator. Be certain to engage each keyed and color-coded connector to the matching connector receptacle. You can be certain that each connector is fully engaged in its receptacle by listening carefully for a distinct, audible click as the connector latches snap into place.
17. Be certain to fully engage the plastic push-in retainer (2) of the clockspring pigtail wires into the locator hole (3) at the 12 o'clock position on the back of the airbag housing (Figure 6).
18. Carefully position the DAB (1) into the hub cavity of the steering wheel (2). Be certain that the clockspring pigtail wires and the steering wheel wire harness are not pinched between the DAB and the horn switch, the steering wheel armature or, on vehicles equipped with a diesel engine, the steering wheel damper weight (Figure 5).
19. Engage the lower airbag snap retainer wire loop (3) onto the lower hook of the steering wheel armature. The lower snap retainer wire loop has a distinctive V-shape and must always be installed onto the six o'clock hook of the steering wheel armature (Figure 5).
20. Roll the DAB upwards and press firmly and evenly over the two upper snap retainer wire loop locations simultaneously until they snap into place over the two upper hooks of the steering wheel armature.

NOTE: If the vehicle is equipped with an automatic transmission, be certain to engage the gearshift lever boot into the opening in both shroud halves.

21. Position the upper shroud (1) onto the steering column over the lower shroud (3) (Figure 2).
22. Align the snaps features on the upper and lower shroud halves and apply hand pressure to snap together.
23. From below the steering column, install the two outboard screws within the recess areas (2) that secure the upper shroud (1) to the lower shroud (3) (Figure 2).

NOTE: Do not reconnect the negative cable to the battery at this time. The Supplemental Restraint System (SRS) Verification Test procedure should be performed following service of any SRS component.

NOTE: The following procedure should be performed using a diagnostic scan tool to verify proper Supplemental Restraint System (SRS) operation following the service or replacement of any SRS component. Refer to the appropriate diagnostic procedures.

24. During the following test, the negative cable remains disconnected and isolated from the battery, as it was during the Supplemental Restraint System (SRS) component removal and installation procedures.

25. Be certain that the diagnostic scan tool contains the latest version of the proper diagnostic software. Connect the scan tool to the 16-way Data Link Connector (DLC) (2). The DLC is located on the driver side lower edge of the instrument panel, near the steering column opening cover (1) and outboard of the steering column (Figure 17).

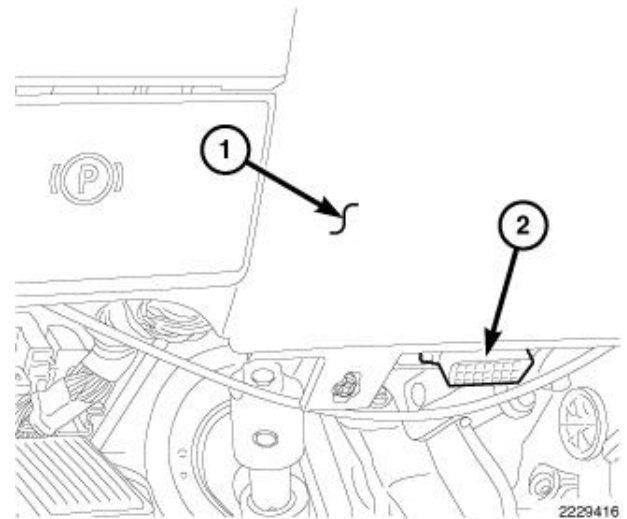

Figure 17 – DLC

26. Transition the status of the ignition switch (also known as the Keyless Ignition Node/KIN or Ignition Node Module/IGNM) to ON and exit the vehicle with the scan tool.

27. Check to be certain that nobody is in the vehicle, then connect the negative cable to the battery.

28. Using the scan tool, read and record the active (current) Diagnostic Trouble Code (DTC) data.

29. Next, use the scan tool to read and record any stored (historical) DTC data.

30. If any DTC is found in **Step 28** or **Step 29**, refer to the appropriate diagnostic information.

31. Use the scan tool to erase the stored DTC data. If any problems remain, the stored DTC data will not erase. Refer to the appropriate diagnostic information to diagnose any stored DTC that will not erase. If the stored DTC information is successfully erased, go to **Step 32**.

32. Transition the status of the ignition switch to OFF for about 15 seconds, and then back to ON. Observe the airbag indicator in the instrument cluster. It should light from four to six seconds, and then go out. This indicates that the SRS is functioning normally and that the repairs are complete. If the airbag indicator fails to light, or lights and stays ON, there is still an active SRS fault or malfunction. Refer to the appropriate diagnostic information to diagnose the problem.

NOTE: Proper SCCM installation must also be confirmed by viewing the SAS menu item, Data Display function using a diagnostic scan tool.

SERVICE PROCEDURE – DP, DJ, DF, DD AND D2

G. Remove SCCM

WARNING: To avoid serious or fatal injury on vehicles equipped with airbags, disable the Supplemental Restraint System (SRS) before attempting any steering wheel, steering column, airbag, seat belt tensioner, impact sensor or instrument panel component diagnosis or service. Disconnect and isolate the battery negative (ground) cable, then wait two minutes for the system capacitor to discharge before performing further diagnosis or service. This is the only sure way to disable the SRS. Failure to take the proper precautions could result in accidental airbag deployment.

WARNING: To avoid serious or fatal injury, use extreme care to prevent any foreign material from entering the Driver AirBag (DAB), or becoming entrapped between the DAB cushion and the DAB trim cover. Failure to observe this warning could result in occupant injuries upon airbag deployment.

CAUTION: If the clockspring is not properly centered in relation to the Steering Angle Sensor (SAS), steering wheel, steering shaft and steering gear, it may be damaged or Diagnostic Trouble Codes (DTC) may be set in the SAS. Service replacement clocksprings are shipped pre-centered and with a locking pin installed. This locking pin should not be removed until the clockspring has been installed on the steering column.

1. Place the front wheels in the straight-ahead position.

NOTE: If the vehicle is equipped with an auxiliary battery, when disconnecting and isolating the negative battery cable for the 12-volt system, both batteries will need to be disconnected to power down the vehicle.

2. Disconnect the Intelligent Battery Sensor (IBS) wire harness connector (1) (Figure 18).

NOTE: Failure to disconnect the IBS wire harness connector can lead to damage of the IBS wire harness connector.

3. Loosen the ground terminal nut (2) and remove the negative battery cable with IBS from the battery and isolate it.

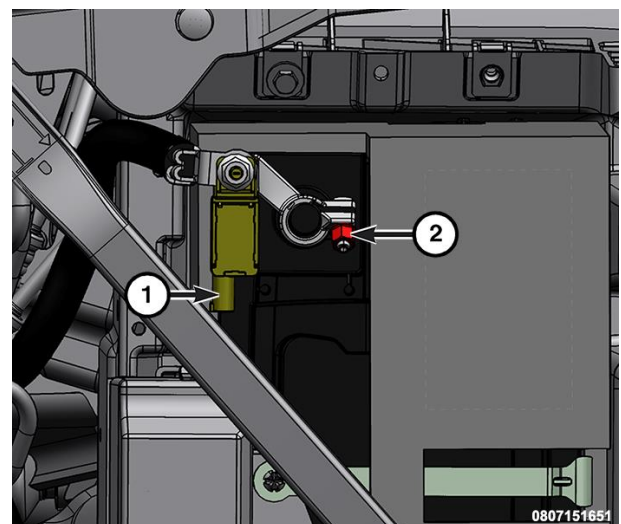

Figure 18 – IBS Connector

4. If the vehicle is equipped with an auxiliary battery, Loosen the clamp (1) and remove the clamp from the battery and isolate.

NOTE: If the vehicle is equipped with an auxiliary battery, install the negative clamp on the negative battery post and tighten to the proper torque specifications prior to connecting the IBS.

5. Wait 2 minutes for capacitor discharge.
6. Locate the access hole dimples (1) in the lower surface of the steering wheel hub rear trim cover near each of the two horizontal spokes.
7. Using the Remover, Driver Air Bag 2050200100, pierce the trim cover at the dimple and insert it through one of the steering wheel access holes. A guide and notch integral to each side of the steering wheel hub rear trim cover and the mounting/horn switch plate will assist in directing the tool to the ends of the retainer spring (Figure 19).



1022127273

Figure 19 – DAB Removal

8. When the tool makes contact with the retainer spring, push inward (toward the steering column) on the tool far enough to disengage the retainer spring from under the hook of the steering wheel armature.
9. Pull the released side of the DAB away from the steering wheel far enough to insert a trim stick or another long and thin obstacle between the released spoke of the DAB trim cover and the steering wheel spoke hub cavity. This will help to prevent the released end of the retainer spring from becoming accidentally engaged again while the opposite end of the retainer spring is being released.
10. Repeat Steps 6 and 7 for the opposite end of the retainer spring.

SAFETY RECALL
NORTH AMERICA
Malfunctioning SCCM



Reference: B2A / NHTSA 23V-799

FCA US LLC

11. Pull the DAB away from the steering wheel far enough to access the steering wheel wire harness connector to the DAB inflator initiators (1) (Figure 20).

CAUTION: Do not pull on the clockspring pigtail wires or pry on the connector insulators to disengage them from the Driver AirBag (DAB) inflator initiator connector receptacles. Improper removal of these pigtail wires and their connector insulators can result in damage to the airbag circuits or the connector insulators.

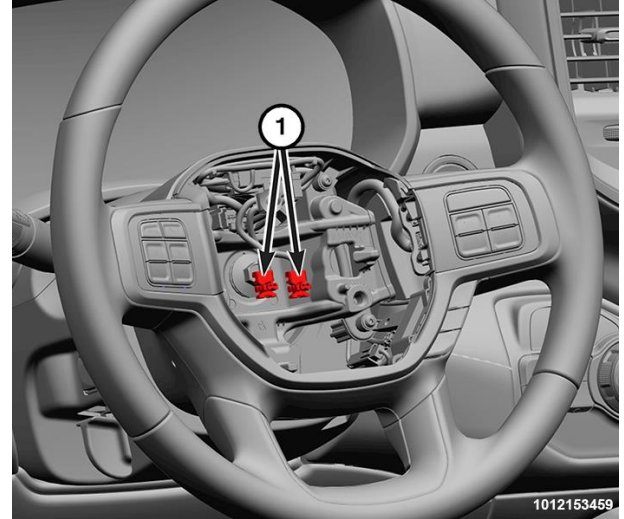

Figure 20 – Steering Wheel Wire Harness Connectors

12. The clockspring DAB pigtail wire connector insulators are secured by integral latches and a Connector Position Assurance (CPA) lock to the airbag tether cutter and inflator connector receptacles, which are located on the back of the floating horn switch plate and the DAB housing. Pull the lock straight away from the connector insulator, then pull the insulators straight away from the connector receptacles to disengage and disconnect them (Figure 20).
13. Remove the DAB and floating horn switch plate from the steering wheel as a unit.
14. Disconnect the steering wheel wire harness connectors (1) (Figure 21).
15. If equipped, disconnect the heated steering wheel wire harness connectors.
16. Remove and **DISCARD** the steering wheel bolt (2) and retain the damper if equipped (Figure 21).

NOTE: If the steering wheel cannot be removed by hand, a commercially available puller may be used to remove the steering wheel.

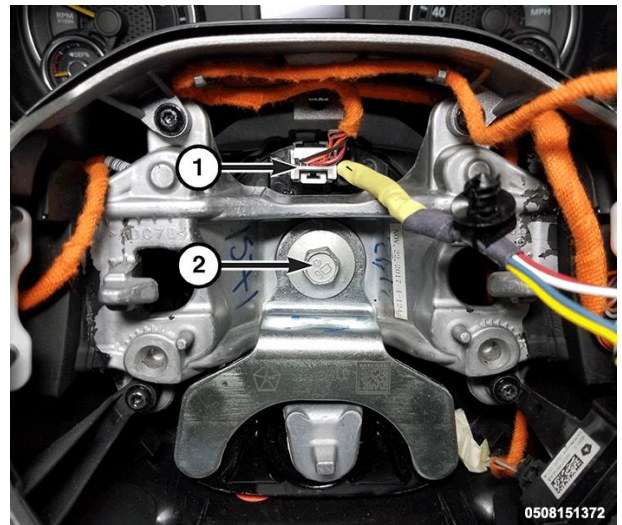

Figure 21 – Steering Wheel Wire Harness Connectors

17. Remove the three steering column shroud screws (Figure 22).



Figure 22 – Steering Column Shroud Screws

SAFETY RECALL
NORTH AMERICA
Malfunctioning SCCM



Reference: B2A / NHTSA 23V-799

FCA US LLC

- 18. If equipped, release the shifter boot (1) from the steering column shroud (Figure 23).
- 19. Disengage the upper steering column shroud tabs (2) from the lower steering column shroud (Figure 23).

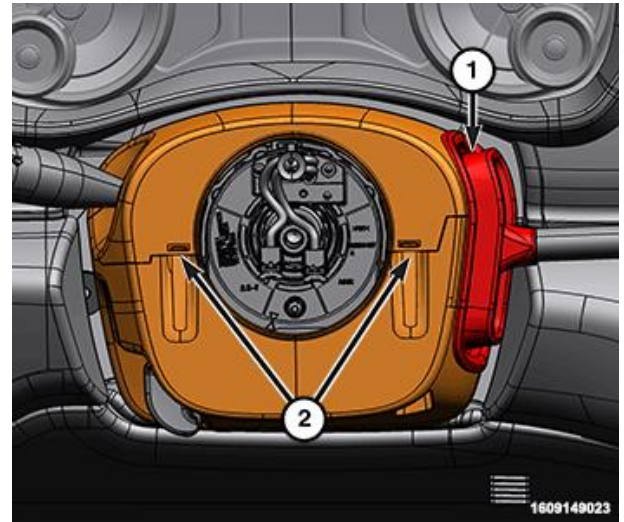

Figure 23 – Steering Column Shroud

- 20. Disengage the gap hider (1) from the upper steering column shroud (2) and remove the upper steering column shroud (Figure 24).



1609152890

Figure 24 – Gap Hider

SAFETY RECALL
NORTH AMERICA
Malfunctioning SCCM



Reference: B2A / NHTSA 23V-799

FCA US LLC

21. Remove the lower steering column shroud screws (2), then the shroud (1) (Figure 25).



Figure 25 – Lower Steering Column Shroud

22. Secure the SCCM in the straight-ahead position.
23. Remove the screws (1) (Figure 26 and 27).

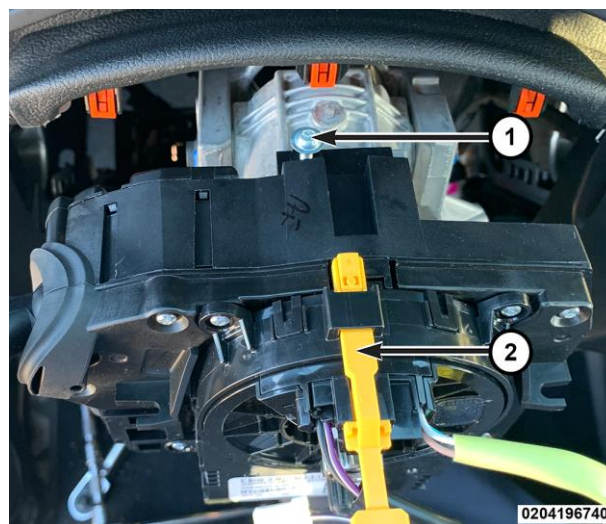

Figure 26 – SCCM

SAFETY RECALL
NORTH AMERICA
Malfunctioning SCCM



Reference: B2A / NHTSA 23V-799

FCA US LLC

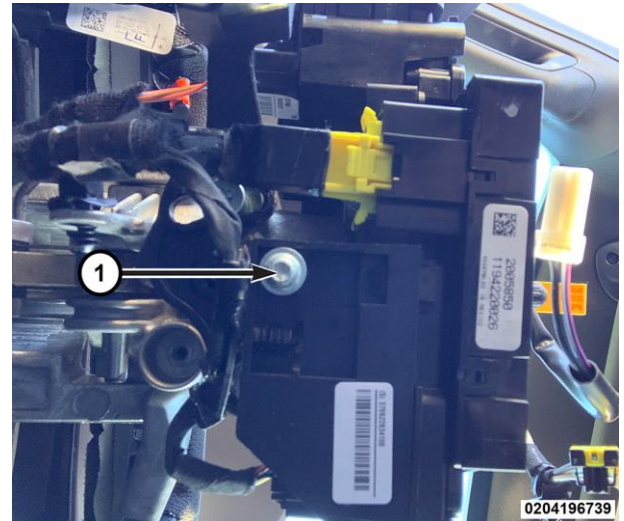

Figure 27 – SCCM

24. Pull the SCCM slightly away from the steering column and disconnect the pedal adjustment wire harness connector (4), if equipped (Figure 28).
25. Remove the SCCM from the steering column.
26. Disengage the wire harness routing clip (1) (Figure 28).
27. Disconnect the wire harness connectors (2 & 3) (Figure 28).

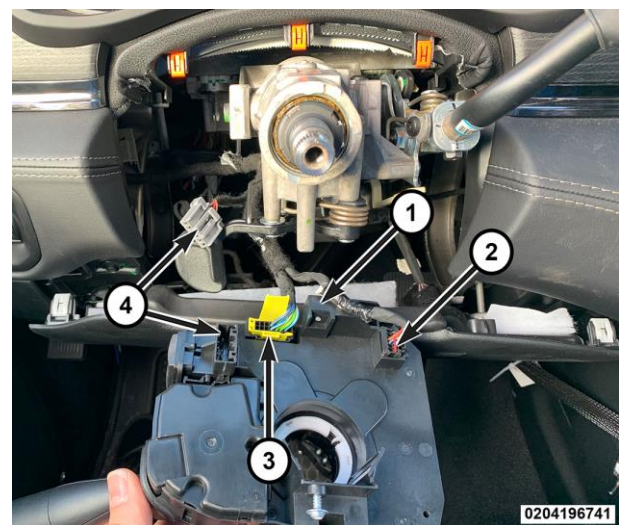

Figure 28 – SCCM

H. Install SCCM

NOTE: The Steering Column Control Module (SCCM) centering can be verified by visually confirming the blue striped ribbon is present in the sight glass (Figure 29).

1. Connect the wire harness connectors (2 & 3) (Figure 28).
2. Secure the wire harness routing clip (1) (Figure 28).
3. While sliding the **NEW** SCCM over the steering column connect the pedal adjustment wire harness connector.
4. Install and securely tighten the SCCM screws (1) (Figure 26 and 27).
5. Position the lower steering column (1) shroud to the steering column (Figure 25).
6. Engage the upper steering column shroud (2) to the gap hider (1) (Figure 24). **Verify that the top shroud is properly secured to the gap hider. Move the tilt column up and down to ensure the gap hider stays connected to the upper shroud.**
7. Install the upper steering column shroud to the lower steering column shroud (Figure 23).
8. If equipped, install the shifter boot (1) to the steering column shroud (Figure 23).
9. Install and securely tighten the three steering column shroud screws (2) (Figure 22).
10. If equipped, connect the heated steering wheel wire harness connectors and secure the steering wheel wire harness.
11. Install the steering wheel to the steering column.
12. If equipped, position the damper to the steering wheel, then install a **NEW** steering wheel bolt and tighten the nut to 61 N·m (45 ft. lbs.) (Figure 21).
13. Connect the two steering wheel wire harness connectors (Figure 20).
14. Position the DAB close enough to the steering wheel to connect the steering wheel wire harness connectors to the DAB inflator initiators (1) (Figures 20 and 21).
15. Connect the clockspring pigtail wire connectors to the airbag inflator initiator connector receptacles by pressing straight in on the connector insulator. Be certain to engage each keyed and color-coded connector to the matching connector receptacle. Be certain that each connector is fully engaged in its receptacle, then push the connector lock straight into the connector to lock it in place.

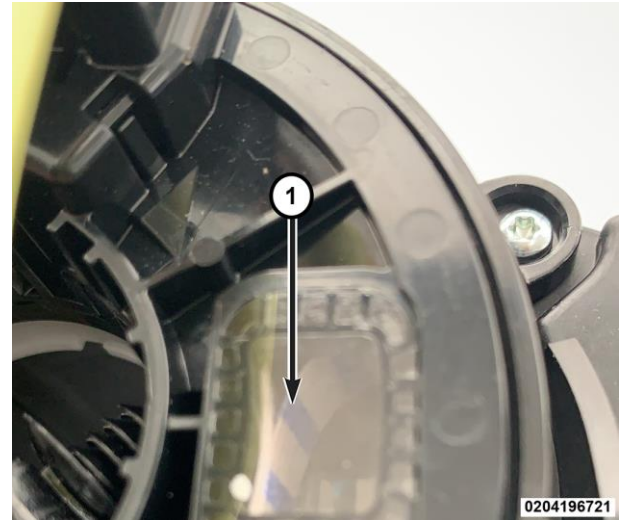

Figure 29 – Blue Stripe Ribbon

16. Carefully position the DAB to the steering wheel hub cavity while tugging lightly upward on the clockspring pigtail wires for the airbag and tucking the wires in the upper hub cavity of the steering wheel. Be certain that none of the steering wheel wiring is pinched between the airbag housing or the horn switch and the steering wheel armature.
17. Using both hands, push firmly and evenly on both sides of the DAB trim cover until both ends of the spring retainer have snapped in place under the hooks within the hub cavity of the steering wheel.
18. Do not connect the negative cable to the battery at this time. The Supplemental Restraint System (SRS) Verification Test procedure should be performed following service of any SRS component.

NOTE: The following procedure should be performed using a diagnostic scan tool to verify proper Supplemental Restraint System (SRS) operation following the service or replacement of any SRS component. Refer to the appropriate diagnostic procedures.

19. During the following test, the negative cable remains disconnected and isolated from the battery, as it was during the Supplemental Restraint System (SRS) component removal and installation procedures.
20. Be certain that the diagnostic scan tool contains the latest version of the proper diagnostic software. Connect the diagnostic scan tool to the 16-way Data Link Connector (DLC). The DLC is located on the driver side lower edge of the instrument panel, near the steering column opening cover and outboard of the steering column.
21. Check to be certain that there are no occupants in the vehicle, then connect the negative battery cable. If equipped with an Intelligent Battery Sensor (IBS), connect the IBS connector.
22. If the vehicle is equipped with Keyless Go, follow the warning below.

WARNING: After disconnecting the 12-Volt battery wait two minutes before proceeding. Remove the ORC fuses, connect the 12-Volt battery, wait two minutes before proceeding. Cycle the ignition to the on position, then reconnect the orc fuses. Failure to follow these instructions may result in possible serious or fatal injury.

23. For vehicles with a standard ignition follow the warning below.

WARNING: Turn the ignition on, then reconnect the 12-Volt battery. Failure to follow these instructions may result in possible serious or fatal injury.

24. Exit the vehicle with the diagnostic scan tool.
25. Using the diagnostic scan tool, read and record the active (current) Diagnostic Trouble Code (DTC) data.
26. Next, use the diagnostic scan tool to read and record any stored (historical) DTC data.
27. If any DTC is found in **Step 25** or **Step 26**, refer to the appropriate diagnostic information.
28. Use the diagnostic scan tool to erase the stored DTC data. If any problems remain, the stored DTC data will not erase. Refer to the appropriate diagnostic information to diagnose any stored DTC that will not erase. If the stored DTC information is successfully erased, go to **Step 29**.

SAFETY RECALL
NORTH AMERICA
Malfunctioning SCCM



Reference: B2A / NHTSA 23V-799

FCA US LLC

-
29. Turn the ignition switch **OFF** for about 15 seconds, and then back to **ON**. Observe the airbag indicator in the instrument cluster. It should light from four to six seconds, and then go out. This indicates that the SRS is functioning normally and that the repairs are complete. If the airbag indicator fails to light, or lights and stays ON, there is still an active SRS fault or malfunction. Refer to the appropriate diagnostic information to diagnose the problem.
 30. If equipped with Steering Assist Module (SAM) perform the reset steering angle calibration standard procedure, **Steps 31 and 32**.
 31. With the vehicle parked on level ground, center the steering wheel.
 32. Using the scan tool, under Steering Assist Module (SAM) select "**Miscellaneous Functions**" and perform the "**Steering Angle Calibration**" routine.

NOTE: Proper SCCM installation must also be confirmed by viewing the SAS menu item, Data Display function using a diagnostic scan tool.