



Service Bulletin

Front Corner Weld Reinforcement on Fiberlite POD and POD XL Replaceable Tongue Frame

Pelsue Company is committed to the continuous improvement of our products, for both products currently in production and those products already in use by our customers. As part of this commitment, Pelsue has identified a potential issue with the frame of replaceable POD and XL trailers, particularly when towed at an unlevel angle behind a 1-1/4-ton truck or larger.

To increase the robustness of these frames, we have developed a pair of external brackets to be applied on each front corner of the trailer frame to better support the welded front cross member. These trusses will be bolted in place and do not affect the replaceable tongue. The Corner Cap kit (127834-AP1) and installation instructions (127834) will be sent at no cost to you. Our service department will help arrange a nearby repair shop that can install these trusses. The estimated time for installation is approximately 30 minutes.

This Bulletin is intended to assist customers in inspecting their trailer to identify the issue (page 2) and to assess risk of failure (page 3). No tools are required to inspect a trailer for this issue. This document applies to the replaceable tongue version of both Fiberlite POD and Fiberlite XL trailers, although either product may be shown in accompanying pictures.

NOTE: This bulletin does not affect trailers made without the replaceable tongue (early POD and XL, SPOT, MCT, STEER, Grizzly). All POD and XL trailers shipped after January 31, 2023 have this issue resolved and do not need the external trusses applied.



2500 S Tejon St

Englewood, CO 80110

(303) 936-7432

service@pelsue.com

Front Corner Weld Reinforcement on Fiberlite POD and POD XL Replaceable Tongue Frame

Inspection location – Top View

Inspect the welds between the frame rails and front cross-member. Picture below shows a representative trailer with the impacted areas circled in red.

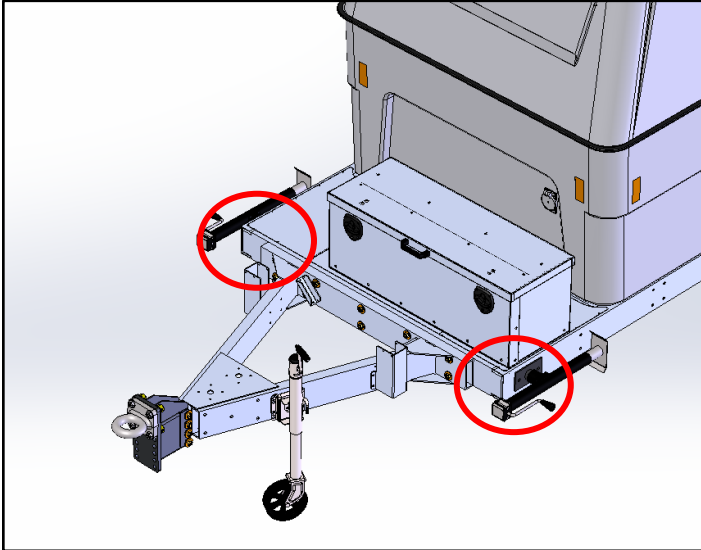

Inspection Location – Bottom View

BEFORE INSPECTING THE UNDERSIDE OF THE TRAILER FRAME: Ensure that the trailer is fixed in place by deploying every jack, including the tongue jack. Prevent accidental rolling by fixing the wheels with wheel chocks. Ensure that everything on and around the trailer is secured before getting under the trailer.

In order to fully inspect the affected areas, the inspector must view the frame from underneath. The representative image below is a view of the front curbside corner of the frame weldment from underneath the trailer. The red arrows point to the specific weld joints to closely inspect for any cracks in or around the welds. Be sure to check the weld joints on both the street side and curbside of the trailer.

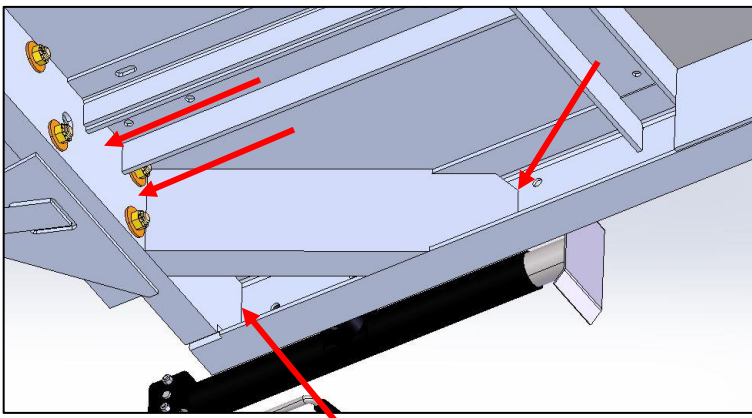



Service Bulletin

**Front Corner Weld Reinforcement on Fiberlite POD
and POD XL Replaceable Tongue Frame**

Front Corner Weld Reinforcement on Fiberlite POD and POD XL Replaceable Tongue Frame

Inspection Findings

In the event that a crack is discovered during the inspection in these areas, do not attempt to use the trailer for routine use.

Representative pictures of cracked welds for a trailer that should be immediately removed from service are below:



With the trailer jacks deployed and the trailer fully secured, remove any heavy equipment (within reason) and contact Pelsue immediately to report the case. Pictures of the trailer and any cracks or failures can be sent to service@pelsue.com along with identifying information on the customer and trailer model.

If no cracks are identified, please call Pelsue Service at 1-303-936-7432 so we can schedule the installation of the Corner Cap Kit specified on page 1 and arrange to ship the components and instructions to the proper installer.