

LAKOTA AXLE CARRIER REPAIR

AUGUST 11, 2023



*Whenever, wherever,
we make your experience better.*

AXLE POD REPAIR

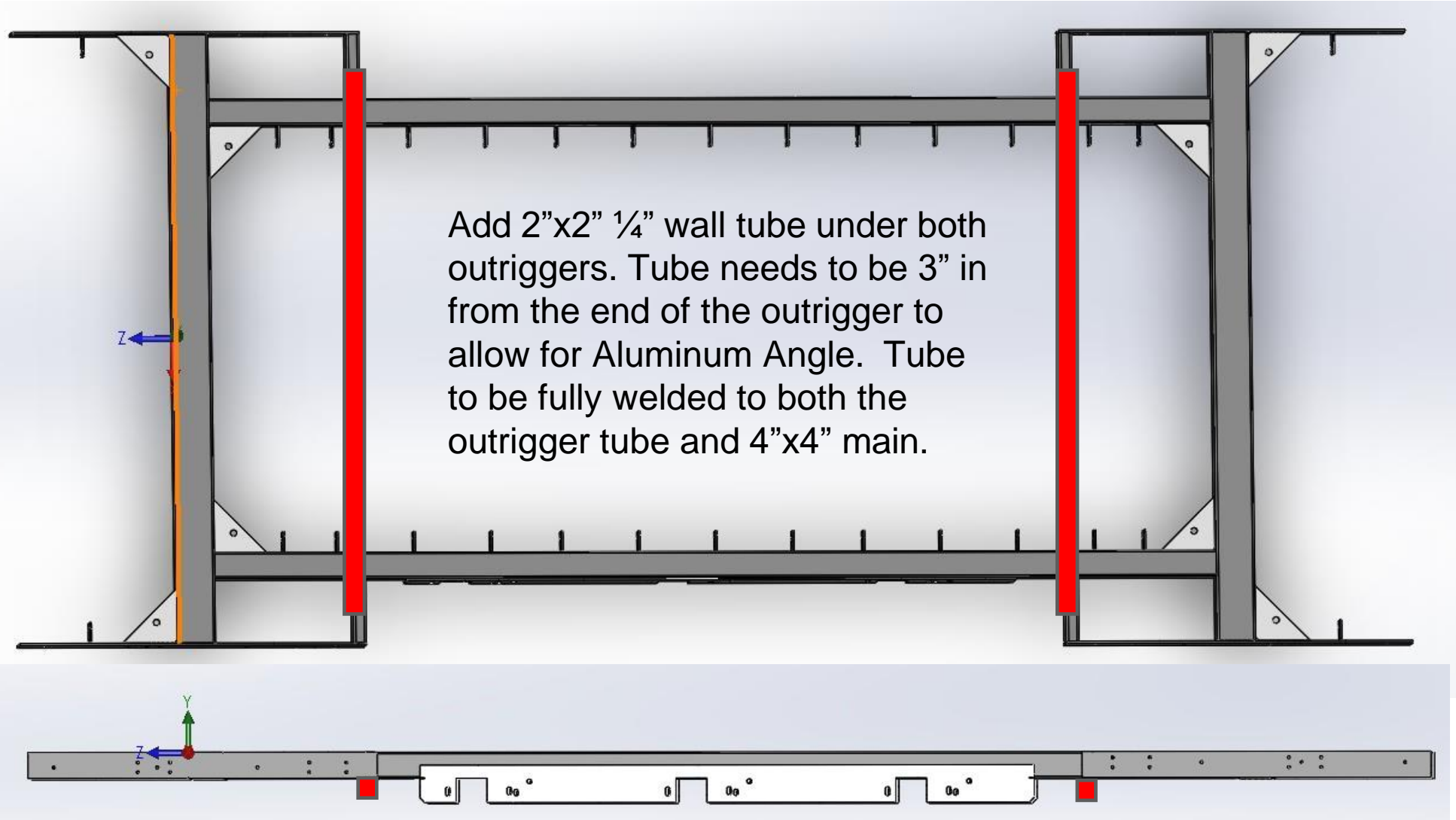

AXLE POD REPAIR



Add gusset (LCI Item 134660) on the outside of the 4X4 Main, reinforcing the joint to the 4X6

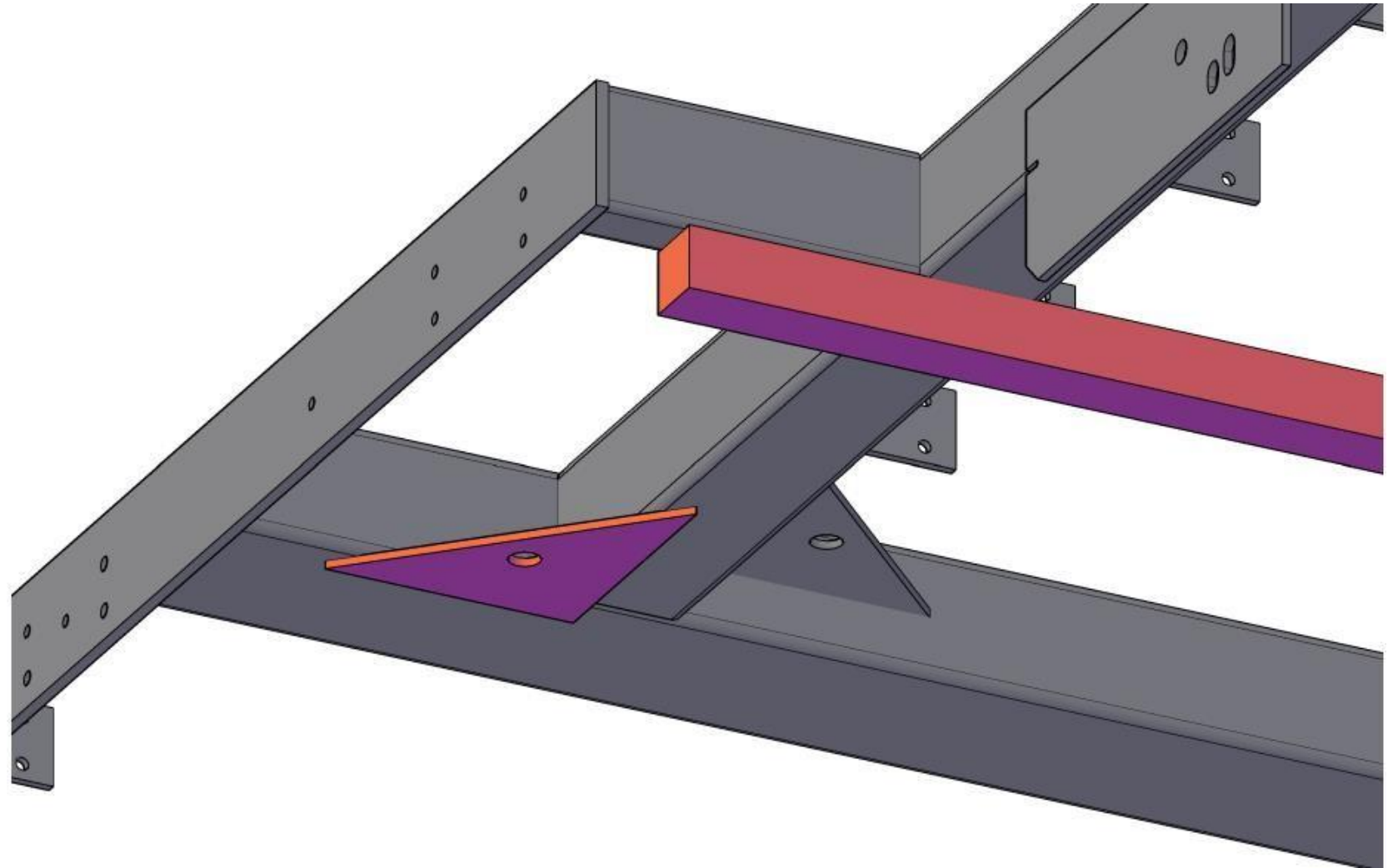

AXLE POD REPAIR

Add in gusset (LCI Item 2020133210) above the outrigger, welding completely to outrigger and main.

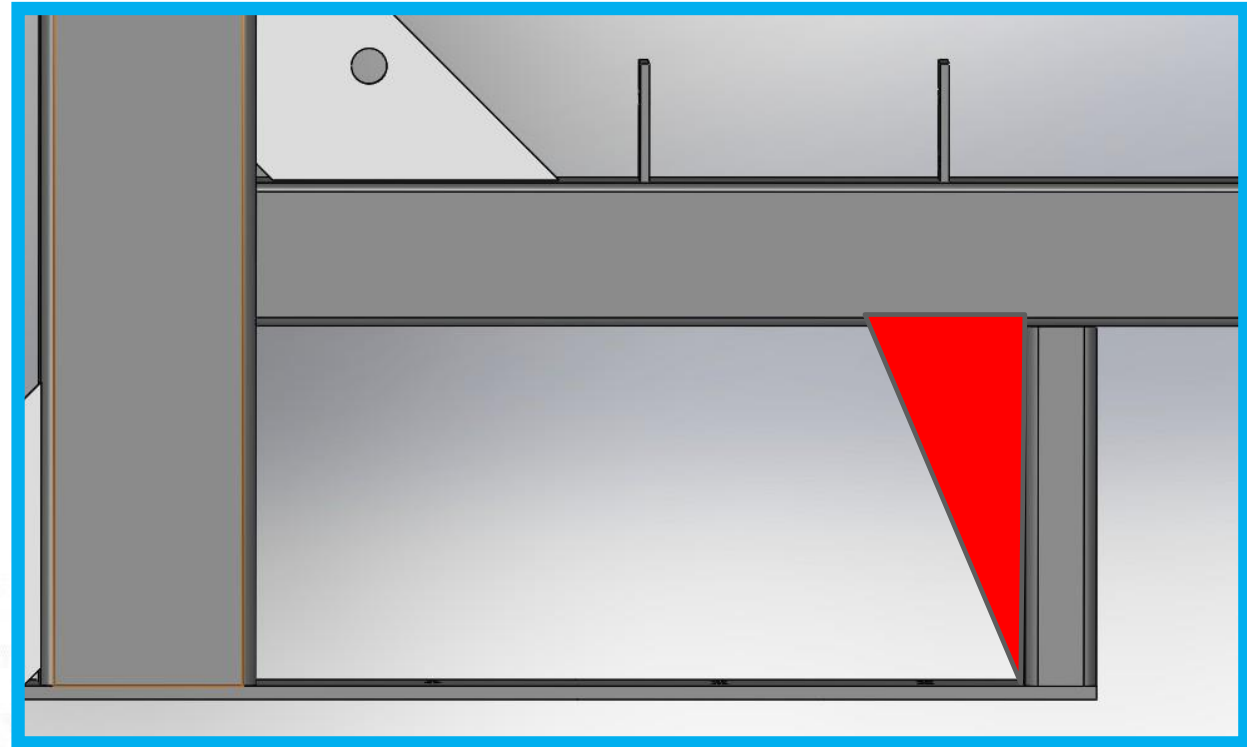
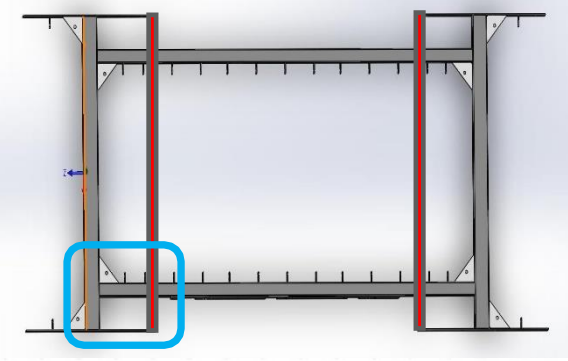

AXLE POD REPAIR

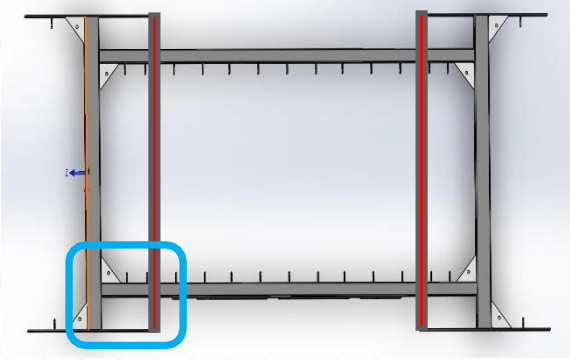

Add 6" tall by 11" long 11 Gauge plate at an angle four places.
Weld to 4 x 4 main and outer plate

