



Remedy available for
 2022-2023 Wagoneer/Grand Wagoneer

Template Version 1.0

Revision	Edition	Detail
0	August 2023	Initial Version.

SYMPTOM DESCRIPTION

The upper B-pillar trim on about 47,980 of the above vehicles may not be fully seated. Vehicles with the upper B-pillar trim not fully seated may have a compromised side airbag inflatable curtain ("SABIC") deployment. A compromised deployment of the SABIC can reduce occupant protection in the event of a crash, resulting in an increased risk of injury to vehicle occupants.

The condition described above does not comply with Federal Motor Vehicle Safety Standard (FMVSS) No. 571.226 Ejection Mitigation.S4.2.1 which states "When the ejection propulsion mechanism propels the ejection impactor into the impact target locations of each side daylight opening of a vehicle according to the test procedures specified in S5 of this standard, the most outboard surface of the ejection head form must not displace more than 100 millimeters beyond the zero displacement plane." Vehicles with the upper B-pillar trim not fully seated may have a compromised side airbag inflatable curtain ("SABIC") deployment that may not meet this requirement.

SCOPE

NOTE: Some vehicles above may have been identified as not involved in this recall and therefore have been excluded from this recall.

IMPORTANT: Some of the involved vehicles may be in dealer new vehicle inventory. Federal law requires you to complete this recall service on these vehicles before retail delivery. Dealers should also consider this requirement to apply to used vehicle inventory and should perform this recall on vehicles in for service. Involved vehicles can be determined by using the VIP inquiry process.

REPAIR TO BE PERFORMED

Inspect and, if necessary, reseal or replace all loose or broken upper B-pillar interior trim pieces.

COMPLETION REPORTING / REIMBURSEMENT

Claims for vehicles that have been serviced must be submitted on the DealerCONNECT Claim Entry Screen located on the Service tab. Claims paid will be used by FCA to record recall service completions and provide dealer payments.

Use the following labor operation numbers and time allowances:

Labor Description	Number	Hrs
Inspect Left and Right Upper B-Pillar Trim Panels	23-76-A1-81	0.2
Inspect and Attach Left and / or Right Upper B-Pillar Trim Panels	23-76-A1-82	0.2
Inspect and Replace Left and / or Right Upper B-Pillar Trim Panels	23-76-A1-83	0.3

NOTE: See the Warranty Administration Manual, Recall Claim Processing Section, for complete recall claim processing instructions.

PARTS INFORMATION

Any required part(s) will be determined after inspection. Very few vehicles are expected to require trim replacement. Do NOT order parts on this list in advance of inspection as not everything on the list is required for every vehicle. Vehicles that pass inspection require NO parts.

Body Model	Interior Color Sales Code	R/L	Part Number
L – Wagoneer PC0 M – Wagoneer Series I H – Wagoneer Series II P – Wagoneer Series III	-D7	Right	6LF24SD4AD
		Left	6LF25SD4AD
	-X7	Right	6LF24TX7AD
		Left	6LF25TX7AD
R – Grand Wagoneer Series I	-D7	Right	7FM02SD4AC
		Left	7FM03SD4AC
	-X7	Right	7FM02TX7AC
		Left	7FM03TX7AC
S – Grand Wagoneer Series II T – Grand Wagoneer Series III	-D7	Right	6LF28SD4AD
		Left	6LF29SD4AD
	-X7, -T7	Right	6LF28TX7AD
		Left	6LF29TX7AD
	-A6	Right	6LF28WA6AD
		Left	6LF29WA6AD

PARTS RETURN

No parts return required for this campaign.

SPECIAL TOOLS

No special tools are required.

DEALER NOTIFICATION

To view this notification on DealerCONNECT, select “Global Recall System” on the Service tab, then click on the description of this notification.

OWNER NOTIFICATION / SERVICE SCHEDULING

All involved vehicle owners known to FCA are being notified of the service requirement by first class mail. They are requested to schedule appointments for this service with their dealers. A generic copy of the owner letter is attached.

VEHICLE LISTS, GLOBAL RECALL SYSTEM, VIP AND DEALER FOLLOW UP

All involved vehicles have been entered into the DealerCONNECT Global Recall System (GRS) and Vehicle Information Plus (VIP) for dealer inquiry as needed.

GRS provides involved dealers with an updated VIN list of their incomplete vehicles. The owner’s name, address and phone number are listed if known. Completed vehicles are removed from GRS within several days of repair claim submission.

To use this system, click on the “**Service**” tab and then click on “**Global Recall System**.” Your dealer’s VIN list for each recall displayed can be sorted by: those vehicles that were unsold at recall launch, those with a phone number, city, zip code, or VIN sequence.

Dealers must perform this repair on all unsold vehicles before retail delivery. Dealers should also use the VIN list to follow up with all owners to schedule appointments for this repair.

Recall VIN lists may contain confidential, restricted owner name and address information that was obtained from the Department of Motor Vehicles of various states. Use of this information is permitted for this recall only and is strictly prohibited from all other use.

SAFETY RECALL
NORTH AMERICA
Upper B-Pillar Trim



Reference: 76A / NHTSA 23V-545

FCA US LLC

ADDITIONAL INFORMATION

FCA US LLC.

If you have any questions or need assistance in completing this action, please contact your Service and Parts District Manager.

Customer Services / Field Operations

SERVICE PROCEDURE

A. Inspect

1. Inspect the upper B-pillar trim for proper fit to the pillar and that it is firmly attached. Grasp the top edge of the panel and tug on it to see if the upper clip is fully seated. Check both sides of the vehicle. (Figure 1). If there is a gap, or the panel is loose, try reattaching the panel by pressing it firmly in the area of the small AIRBAG screw cover.
2. Does the trim fit properly, or did it snap into place?
 - Yes: There is no issue. Return the vehicle to the customer.
 - No: Replace the upper B-Pillar trim panel. Proceed to Step 3.



Figure 1 – Check Upper B-Pillar Trim Fit

B. Remove

NOTE: Left side shown, right side similar.

NOTE: Take the proper precautions to protect the B-pillar trim from cosmetic damage.

NOTE: Adjust seats for best B-pillar access.

SAFETY RECALL
NORTH AMERICA
Upper B-Pillar Trim



Reference: 76A / NHTSA 23V-545

FCA US LLC

- Using a trim stick or equivalent at the top and bottom edges, remove the B-pillar air outlet (Figure 2).



Figure 2 – B-Pillar Air Outlet

- Using a trim stick or equivalent, release the center B-pillar trim panel and remove it from the vehicle (Figure 4).



Figure 4 – Center B-Pillar Trim

SAFETY RECALL

NORTH AMERICA

Upper B-Pillar Trim



Reference: 76A / NHTSA 23V-545

FCA US LLC

- Using a flat blade screwdriver rotate the tensioner quick connect screw (1) counter clockwise to disconnect the front seat belt retractor lower buckle (2) to the tensioner cable (3) (Figure 5).

NOTE: When rotated counter-clockwise fully, you will hear a slight click as the mechanism latches into the unlocked position. When reassembling, simply press the cable end into the lower buckle, and the mechanism will unlatch and return to the locked position. Always verify that the lower buckle locks properly to the cable.

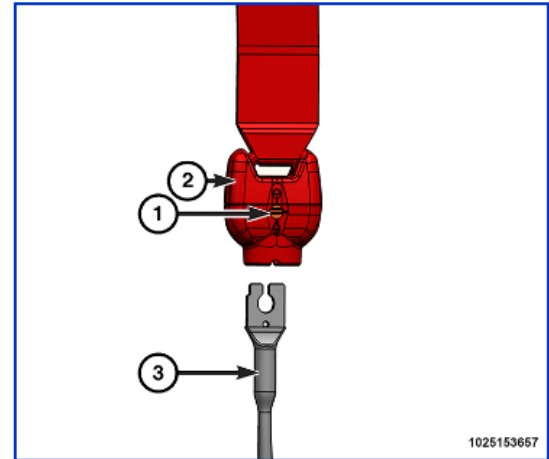

1 - Tensioner Quick Connect Screw

2 - Front Seat Belt Retractor Lower Buckle

3 - Tensioner Cable

Figure 5 – Tensioner Cable

- Partially remove the front and rear door seals from the B-pillar.
- Using a trim stick or equivalent, disengage the retaining clips that secure the upper B-pillar trim panel (1) to the pillar (Figure 6).

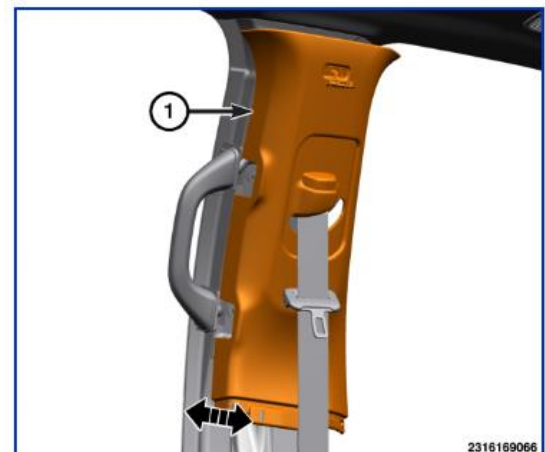

1 - Upper B-pillar Trim Panel

Figure 6 – Upper B-Pillar Trim

C. Install

8. Align the trim clips on the upper B-pillar trim with the slots in the B-pillar and press the trim into place. Hand tap panels to seat fully. Verify panel alignment and tab engagement (Figure 6).
9. Install the front and rear door seals to the B-pillar.
10. Using a flat blade screwdriver rotate the tensioner quick connect screw (1) counterclockwise to connect the front seat belt retractor lower buckle (2) to the tensioner cable (3) (Figure 5).
11. Aligning the clips and tabs with the B-pillar, press the center B-pillar trim panel and install it to the vehicle (Figure 4).
12. Install the B-pillar air outlet (Figure 2).
13. Complete the check and/or repair for the other B-pillar.
14. Return the vehicle to the customer.