

SAFETY RECALL – NORTH AMERICA

High Voltage Battery Fuse



Reference: 53A / NHTSA 23V-303

FCA US LLC



Remedy available for:
2022-2023 (JL) Jeep® Wrangler 4XE PHEV

Template Version 1.0

Revision	Edition	Detail
0	May 2023	Initial Version.

SYMPTOM DESCRIPTION

The high voltage battery on about 2,560 of the above vehicles may have been built with incorrect fasteners securing the 200 amp fuse in the High Voltage (HV) battery. An incorrect fastener can cause high resistance in the 200 amp fuse interface, which will generate heat. Customer may notice a Malfunction Indicator Lamp (MIL), a change in drivability, and/or noise at the HV battery pack assembly. Excessive heat in the fuse interface may cause the fuse to fail resulting in a loss of motive power, which can cause a vehicle crash without prior warning.

SCOPE

This recall applies only to the above Plug-In Hybrid Electric Vehicles (PHEV) equipped with a 2.0L engine (sales code ECX).

NOTE: Some vehicles above may have been identified as not involved in this recall and therefore have been excluded from this recall.

IMPORTANT: Some of the involved vehicles may be in dealer new vehicle inventory. Federal law requires you to complete this recall service on these vehicles before retail delivery. Dealers should also consider this requirement to apply to used vehicle inventory and should perform this recall on vehicles in for service. Involved vehicles can be determined by using the VIP inquiry process.

REPAIR TO BE PERFORMED

Inspect fuse tray 200A fuse for proper fasteners and signs of carbon marks on bus bars. If incorrect fasteners are found with no carbon marks on bus bars, replace the 200A fuse and fasteners. If carbon marks are found, photograph the fasteners and bus bar contacts then replace HV battery as directed by the service procedure.

ALTERNATE TRANSPORTATION

Dealers should attempt to minimize customer inconvenience by placing the owner in a loaner vehicle if inspection determines that the vehicle must be held overnight

COMPLETION REPORTING / REIMBURSEMENT

Claims for vehicles that have been serviced must be submitted on the DealerCONNECT Claim Entry Screen located on the Service tab. Claims paid will be used by FCA to record recall service completions and provide dealer payments.

Use the following labor operation numbers and time allowances:

Labor Description	Number	Hrs
Inspect 200A Fuse, Passed Inspection	08-53-A1-81	0.8
Inspect/Replace 200A Fuse	08-53-A1-82	1.0
Inspect 200A Fuse / Replace PHEV Battery	08-53-A1-83	3.2

Add the cost of the recall parts plus applicable dealer allowance to your claim.

NOTE: See the Warranty Administration Manual, Recall Claim Processing Section, for complete recall claim processing instructions.

PARTS INFORMATION

NOTE: All vehicles will require the Authorized Modifications Label.

Part No.	Qty.	Part Name
04275086AE	1	Label - Authorized Modifications

NOTE: If Inspection Procedure confirms that a new fuse and fasteners are required, order Fuse Campaign Kit below:

Part No.	Qty.	Part Name
CSANZ711AA	1	Fuse Campaign Kit
<i>Campaign kit contains the following components:</i>		
	1	200 Amp Fuse
	2	Fasteners

Strictly respect STELLANTIS Group safety, cleanliness, and environmental instructions for any vehicle service.
Document exclusively reserved for dealer information. Internal distribution to be ensured by dealer.
Reproduction forbidden without the written agreement of STELLANTIS Group.

(tdb)

SAFETY RECALL – NORTH AMERICA

High Voltage Battery Fuse



Reference: 53A / NHTSA 23V-303

FCA US LLC

NOTE: If Inspection Procedure confirms that a new battery is required, open a STAR case. Photographs of battery contacts damage must be attached to the STAR case.

Part No.	Qty.	Part Name
68488244AA	1	400V Battery
68163849AB	1	Coolant
06512293AA	3	Bolt, Rear Seat

PARTS RETURN

Return instructions for the old battery are included in the container with the new battery. There is a [REDACTED] core charge for this battery.

NOTE: If the battery return instructions are missing, a battery return I sheet can be downloaded from DealerCONNECT on the “Parts Tab” under the heading “Returns”.

SPECIAL TOOLS

The following special tools are required to perform this service procedure:

Number	Description
126-1587	Meter, Multi – Originally Shipped In Kit Number(s) 10389.
NPN	High Voltage Personal Protection Equipment: Hard Hat, Safety Glasses, Protective Gloves, Safety Barriers, etc. (Consult Service Library High Voltage Safety Procedures)

If service procedure determines that the battery must be replaced. The following special tools are required to perform battery replacement:

Number	Description
NPN	wiTECH MicroPod II / MDP
NPN	Laptop Computer
NPN	wiTECH Software
2035100082	Covers, HEV Battery Terminal
2035203080	Eyebolt, 10mm
2035200080	Lift Straps, HV Battery

DEALER NOTIFICATION

To view this notification on DealerCONNECT, select “Global Recall System” on the Service tab, then click on the description of this notification.

OWNER NOTIFICATION / SERVICE SCHEDULING

All involved vehicle owners known to FCA are being notified of the service requirement by first class mail. They are requested to schedule appointments for this service with their dealers. A generic copy of the owner letter is attached.

VEHICLE LISTS, GLOBAL RECALL SYSTEM, VIP AND DEALER FOLLOW UP

All involved vehicles have been entered into the DealerCONNECT Global Recall System (GRS) and Vehicle Information Plus (VIP) for dealer inquiry as needed.

GRS provides involved dealers with an updated VIN list of their incomplete vehicles. The owner’s name, address and phone number are listed if known. Completed vehicles are removed from GRS within several days of repair claim submission.

To use this system, click on the “Service” tab and then click on “Global Recall System.” Your dealer’s VIN list for each recall displayed can be sorted by: those vehicles that were unsold at recall launch, those with a phone number, city, zip code, or VIN sequence.

Dealers must perform this repair on all unsold vehicles before retail delivery. Dealers should also use the VIN list to follow up with all owners to schedule appointments for this repair.

Recall VIN lists may contain confidential, restricted owner name and address information that was obtained from the Department of Motor Vehicles of various states. Use of this information is permitted for this recall only and is strictly prohibited from all other use.

ADDITIONAL INFORMATION

If you have any questions or need assistance in completing this action, please contact your Service and Parts District Manager.

Customer Services / Field Operations
FCA US LLC.

Strictly respect STELLANTIS Group safety, cleanliness, and environmental instructions for any vehicle service. Document exclusively reserved for dealer information. Internal distribution to be ensured by dealer. Reproduction forbidden without the written agreement of STELLANTIS Group.

(tdb)

SERVICE PROCEDURE

Only individuals with high voltage training and repair qualifications should be allowed to handle, troubleshoot or repair High Voltage or Hybrid components or systems.

Always wear safety glasses.

Review High Voltage Safety Procedures in Service Library section 08, Standard Procedures.

WARNING: Before performing any diagnostic or service procedure, you must thoroughly read and follow all applicable high voltage safety procedures. You must perform the high voltage power down procedures.

Loss of Isolation (LOI) must be performed before high voltage power up in cases where service has been performed on a high-voltage component or when diagnosing a LOI condition.

Be sure to use the proper safety equipment when working on any high voltage system or component. Failure to do so may result in serious or fatal injury.

Wait a minimum of two minutes after performing the high voltage battery disconnect procedure safety procedures before attempting to access the high voltage system, failure to do so may result in serious or fatal injury.

CAUTION: Do not allow coolant to come in contact with any high voltage component electrical connections. Engine coolant will create a conductive path and cannot be effectively removed resulting in a loss of isolation and replacement of the contaminated high voltage component.

A. Power Down the High Voltage System

1. Power down the high voltage system. If the HV battery will not power down or the vehicle has a welded contactor DTC active that will not clear, stop and perform the “**HV Battery Servicing with Welded Contactor(s)**” at the beginning of the PHEV Battery removal procedure in Service Library.

NOTE: When performing any repairs that involve contact with high voltage components or systems, the technician performing repairs on the vehicle must verify that the system remains powered down during high voltage repairs.

- This is done by removing the test points access cover.
 - The high voltage power down procedure must be performed to ensure that the high voltage battery is properly powered down.
 - The technician must know the whereabouts of the test points access cover throughout the repair.
 - The technician must ensure that the test points access cover is not reinstalled while service is being performed.
 - The technician must recheck that the test points access cover has not been reinstalled in cases where the vehicle was unattended.
2. Prepare the work area and familiarize yourself with all HIGH-VOLTAGE SAFETY PROCEDURES related to personal safety and vehicle safety associated with working on a Plug-In Hybrid Electric Vehicle (PHEV). See **High Voltage Safety Procedures** in Service Library section 08, Standard Procedures.

SAFETY RECALL – NORTH AMERICA
High Voltage Battery Fuse



Reference: 53A / NHTSA 23V-303

FCA US LLC

3. Inspect all orange high-voltage cables, and high-voltage components labeled with the high-voltage symbol for physical damage. If damage is present, extra caution must be taken to avoid contact with unprotected high-voltage. Do not insert probes, tools, objects or fluids into damaged high-voltage cables or components.
4. Disconnect any charging equipment. Do not plug in the EVSE Recharge Coupler when working on the vehicle.
5. Turn the ignition to Off by pressing the keyless go button (1) and move keys away from the car a minimum of 20 feet (Figure 1).

NOTE: If the READY indicator is NOT illuminated in instrument cluster, the vehicle is already shut off. DO NOT push the start/stop button as the vehicle may start.

6. **Wait five minutes** to allow the high-voltage system to shut down without setting a fault code.



Figure 1 – Keyless Go Button

7. Disconnect the IBS wire harness connector (2). Remove and isolate the battery negative cable (1) using Covers, HEV Battery Terminal 2035100082 (Figure 2).

8. Remove the F09 (5 amp) fuse (3) from the Power Distribution Center (PDC) (Figure 2).

NOTE: This removes the fused B+ power supply to the Integrated Dual Charger Module (IDCM). Disabling the IDCM disables the DC/DC conversion between the HV battery and the charging output to the low voltage side of the system.

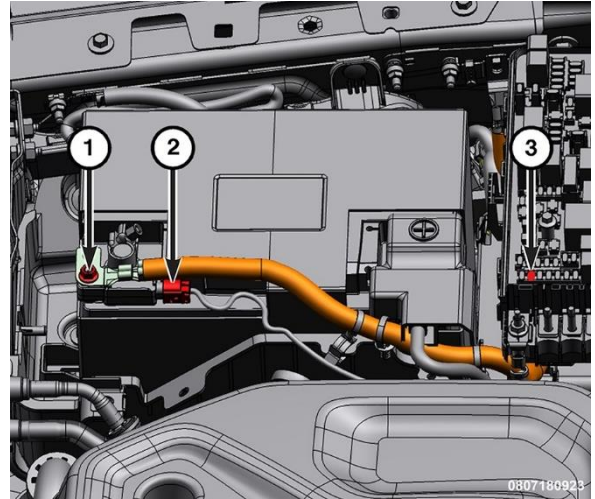

Figure 2 – 12-Volt Battery

- 1 - Battery Negative Cable Nut
- 2 - IBS Wire Harness Connector
- 3 - F09 (5 amp) fuse

9. Verify the multi-meter is operating correctly by measuring voltage from a known good power source, such as the vehicle's 12-volt battery. If at any point during the procedure, the multi-meter settings are changed, or the probes are repositioned in the meter, verification with a known good power source must be repeated.

10. Using a multi-meter, check for voltage at the PDC fused B+ terminal to verify the low voltage system is powered down. The 12-volt electrical system is now powered down. There should be no voltage present with the IDCM disabled and the 12-volt battery disconnected.

SAFETY RECALL – NORTH AMERICA
High Voltage Battery Fuse



Reference: 53A / NHTSA 23V-303

FCA US LLC

11. The high voltage service test points access cover (1) is located on the battery pack, under driver side rear seat cushion (Figure 3).
12. Remove the M6 Torx screws (2) from the high voltage service test points access cover (1) (Figure 3).
13. Carefully remove the test points access cover (1) and set in a protected location such that the cover plate alignment and HVIL pins are not damaged (Figure 3).

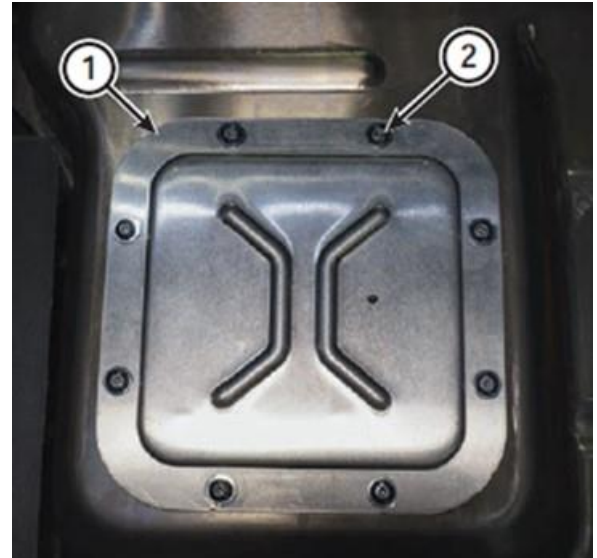

Figure 3 – High Voltage Test Point Access Cover

- 1 - High Voltage Test Point Access Cover
- 2 - M6 Torx Screws

NOTE: Lift the cover straight up to avoid bending or damaging the pin on the cover that is used to engage the HVIL switch (Figure 4).

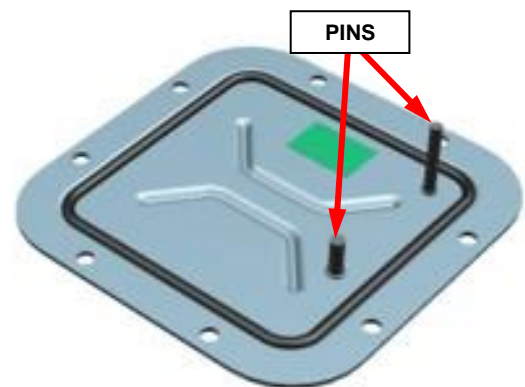

Figure 4 – Access Cover Pins

NOTE: Removal of the test points access cover will affect the following:

- Disables the High Voltage Battery System by disengaging the internal High Voltage Interlock (HVIL) pin from the switch.
- Provides access to the high voltage positive and high voltage negative test points.

NOTE: These circuits are a sense circuit connected through large resistors inside the high voltage battery to the high voltage bus cables after the contactors. These circuits are safe even when high voltage is present on the circuits due to the large resistors reducing these circuits to milliamperes.

- Provides access to the fuse cover screw.
- Allows access to a service lockout loop.

NOTE: Always observe these precautions prior to taking a high-voltage measurement:

- Be sure to utilize the proper Personal Protection Equipment (PPE) when working on any high voltage system.
- Rated and non-expired rubber insulating gloves with leather protectors.
- Have known good test leads.
- Verify the multi-meter leads are rated “CAT III 1,000V”. This should be printed on the multi-meter leads.
- Install the multi-meter leads in the BLACK and RED sockets on the right side of the Fluke 1587 (VΩ (RED) and COM (BLACK)).
- Switch the FLUKE 1587 to the DC Volts selection and press the RANGE button until the 500V range is selected - just one digit (a zero) is displayed.
- Test the multi-meter operation by measuring the voltage across the 12-volt Battery.

SAFETY RECALL – NORTH AMERICA
High Voltage Battery Fuse



Reference: 53A / NHTSA 23V-303

FCA US LLC

14. Use of an insulation tester such as the Fluke Meter, Multi 126-1587 is recommended for PHEV circuit testing. Perform the multi-meter functionality tests per the manufacturer's directions. Verify the multi-meter is operating correctly by measuring voltage from a known good power source, such as the vehicle's 12-volt battery. If at any point during the procedure, the multi-meter settings are changed, or the probes are repositioned in the meter, verification with a known good power source must be repeated (Figure 5).



Figure 5 – Fluke Meter, Multi 126-1587

15. Using the Fluke multi-meter, measure the voltage at the high voltage positive and high voltage negative test points (Figure 6):
- Measure for voltage between the positive and negative high voltage test points.
 - Measure for voltage between positive test point and chassis ground.
 - Measure for voltage between negative test point and chassis ground.



Figure 6 – Measuring at High Voltage Test Points

16. The voltage reading should be 0 volts. (Some residual voltage may be present, up to 2.0 volts may be normal) (Figure 6).
- If the voltage measured is below 2 volts, it is safe to work on the high-voltage components with the exception of the high-voltage battery internal components.
 - If the voltage is greater than 60 volts, an internal condition exists within the high voltage battery such as stuck contactors, that are preventing it from being powered down. This should be accompanied by contactor stuck DTCs. Do not attempt to carry out testing on any of the vehicle's high-voltage components or wiring. The HV Battery Pack requires replacement. Reference the HV BATTERY SERVICING WITH WELDED CONTACTOR(S) procedure at the top of the HV PHEV BATTERY REMOVAL AND INSTALLATION procedure for safely removing a high voltage battery that will not power down (Refer to 08 - Electrical/Battery System/BATTERY/Removal and Installation).
 - If the voltage is between 2.0 volts and 60 volts, the HV system is safe to work on, however there is a problem that should be diagnosed. Disconnect each of the following HV modules one at a time and check the voltage at the test points. If the voltage drops to 2.0 volts or less, the faulted module has been found. Reconnect each module before continuing to the next.
 - Integrated Dual Charger Module (IDCM)
 - Electronic A/C Compressor (EAC)
 - Battery Coolant Heater
 - HV Coolant Heater
 - Power Inverter Module (PIM)

B. High Voltage Fuse Inspection/Replacement

1. Remove the fuse cover screw then remove the fuse cover (Figure 7).

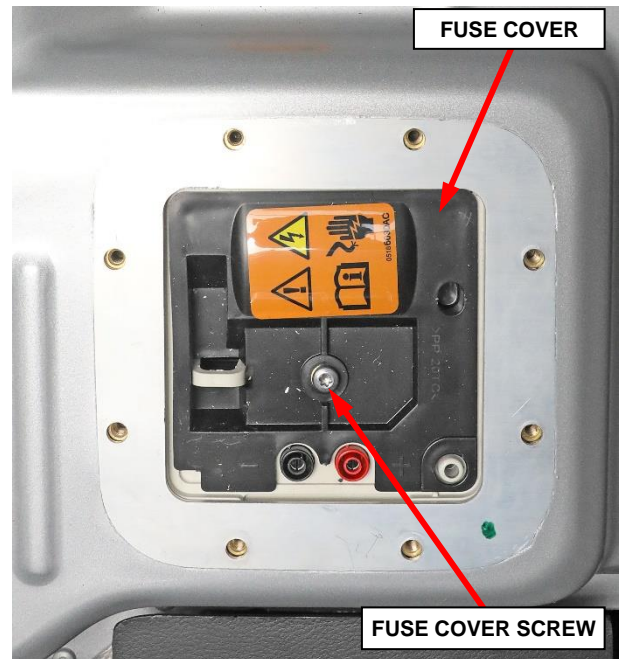

Figure 7 – Fuse Cover

2. Inspect the 200A fuse fasteners in the fuse tray under the fuse cover (Figure 8).

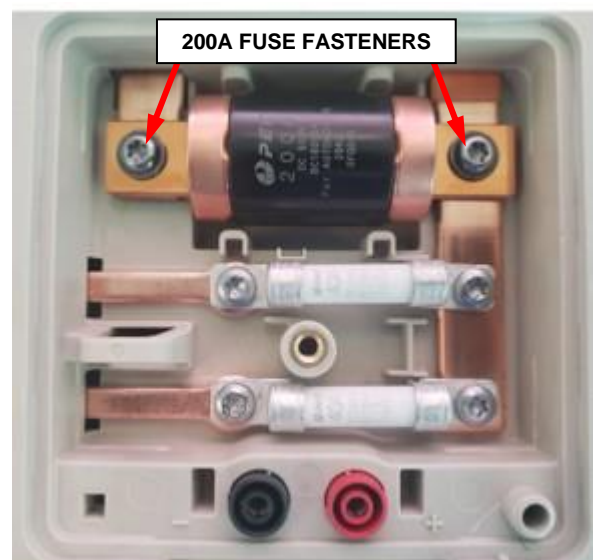
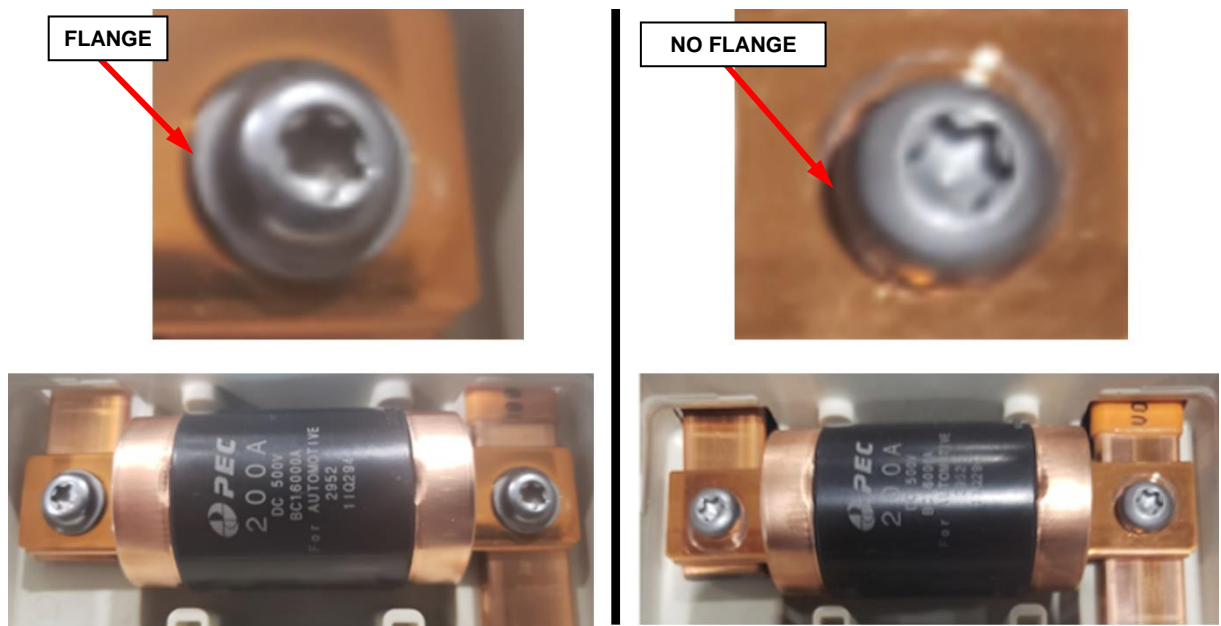

Figure 8 – 200A Fuse Fasteners

3. Do the 200A fuse fasteners have a flange around the screw head or not as shown in (Figure 9)?
- **Correct Screws - Flange Head:** No further action required. Vehicle may be reassembled. Proceed to **Step 10**.
 - **Incorrect Screws – No Flange:** Continue with **Step 4**.



Correct Screws - Flange Head

Incorrect Screws – No Flange

Figure 9 – 200A Fuse Fastener Inspection

4. Remove the incorrect fasteners securing the 200A fuse then also remove the fuse (Figure 9).

5. Inspect the 200A fuse and bus bar contacts for any signs of carbon marking as shown in (Figure 10).

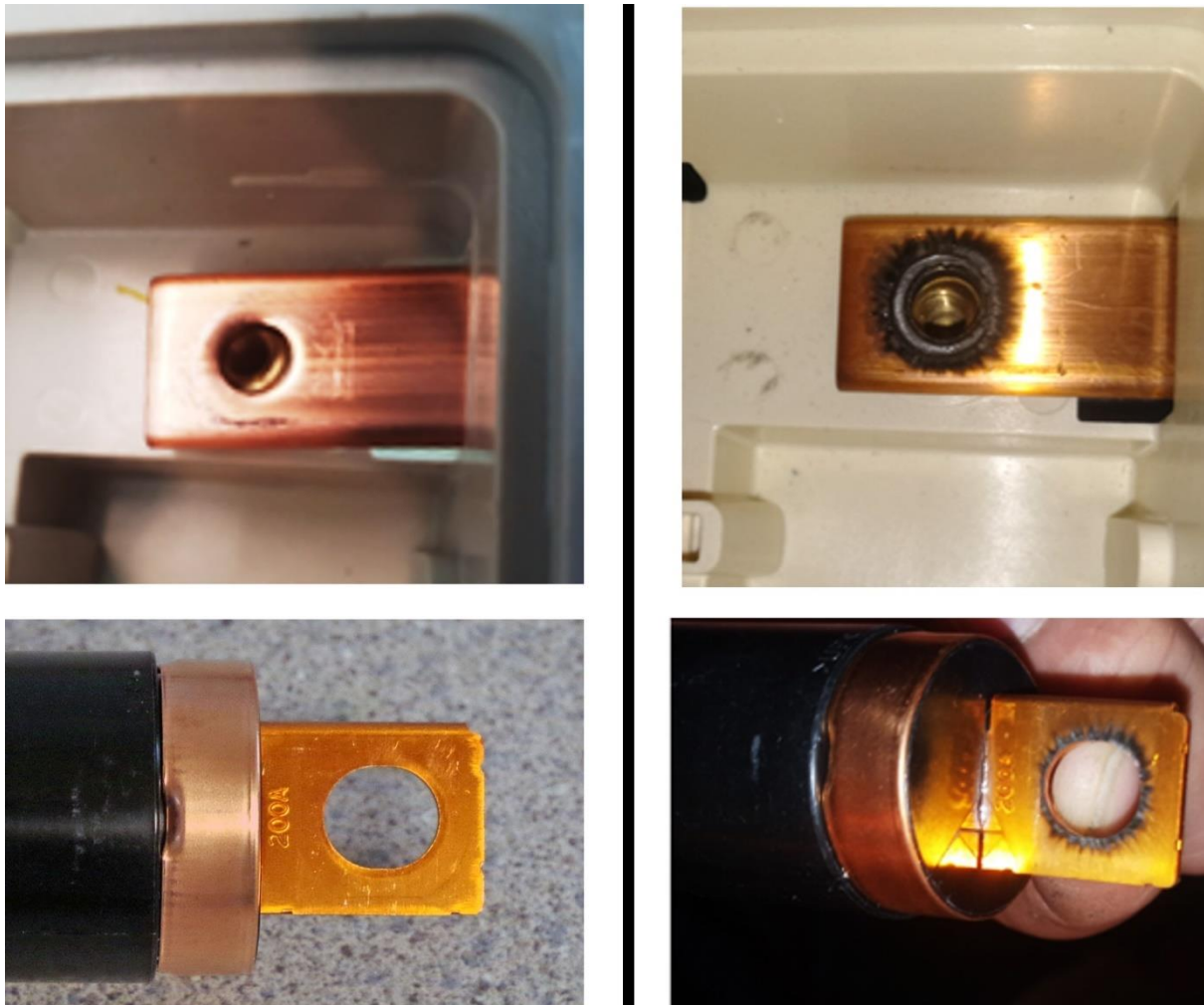

Good Contacts No Carbon Marking

Signs of Carbon Marking

Figure 10 – Inspect for Signs of Carbon Marking

6. Photograph the bus bar and 200A fuse contact surfaces. **Photographs showing the contact surfaces of the bus bar and 200A fuse will be required for the parts ordering process** (Figure 10).

7. Were the bus bar contacts clean or carbon marked as shown in (Figure 10)?
 - **Clean, no Carbon Marks:** Replace the 200A fuse and fasteners. Continue with **Step 8**.
 - **Visible Carbon Marks:** Battery will require replacement Proceed to **Section C**.
8. Order and obtain the 200A fuse kit with proper screws. The photographs taken previously will be required to place the parts order.
9. Replace the 200A fuse and fasteners from the kit then tighten the screws to 5.7 N·m (50 in. lbs.) (Figure 8)
10. Install the fuse cover then tighten the cover screw to 6 N·m (53 in. lbs.) (Figure 7).
11. Power up the HV battery system.

NOTE: When performing any repairs that involve contact with high voltage components or systems, the technician performing repairs on the vehicle must verify that the system remains powered down during high voltage repairs.

- **This must be done by removing the test points access cover.**
- **The high voltage power down procedure must also be performed to ensure that the vehicle is properly powered down.**
- **The technician must know the whereabouts of the test points access cover throughout the repair.**
- **The technician must ensure that no one reinstalls the test points access cover while service is being performed.**
- **The technician must recheck that the test points access cover has not been reinstalled in cases where the vehicle was unattended.**

12. Use of an insulation tester such as the Fluke Meter, Multi 126-1587 is recommended for Plug-In Hybrid Electric Vehicle (PHEV) circuit testing. Perform the multi-meter functionality tests per the manufacturer's directions. Verify the multi-meter is operating correctly by measuring voltage from a known good power source, such as the vehicle's 12-volt battery. If at any point during the procedure, the multi-meter settings are changed, or the probes are repositioned in the meter, verification with a known good power source must be repeated.

NOTE: Always observe these precautions prior to taking an isolation resistance measurement:

- **Have known good test leads**
- **Set the test voltage to 500 Volts**
- **Always wear safety glasses**

13. Using the Meter, Multi 126-1587 measure and record the isolation resistance between the high voltage positive test point and chassis ground (Figure 11).



Figure 11 – Measure and Record Isolation Resistance Between HV Positive Test Point and Chassis Ground

SAFETY RECALL – NORTH AMERICA
High Voltage Battery Fuse



Reference: 53A / NHTSA 23V-303

FCA US LLC

- Using the Meter, Multi 126-1587 measure and record the isolation resistance between the high voltage negative test point and chassis ground (Figure 12).
- Isolation resistance should be 2.3 Mohms (+/- .2). If the measured isolation resistance is outside of this range, a loss of isolation condition exists within the high voltage circuitry. **Do not continue the High Voltage Power Up procedure until the condition causing the loss of isolation is corrected.**¹



Figure 12 – Measure and Record Isolation Resistance Between HV Negative Test Point and Chassis Ground

- Install the test points access cover (1) to the battery pack and tighten the eight M6 Torx screws (2) to 8.8 N·m (78 in. lbs.) (Figure 13).

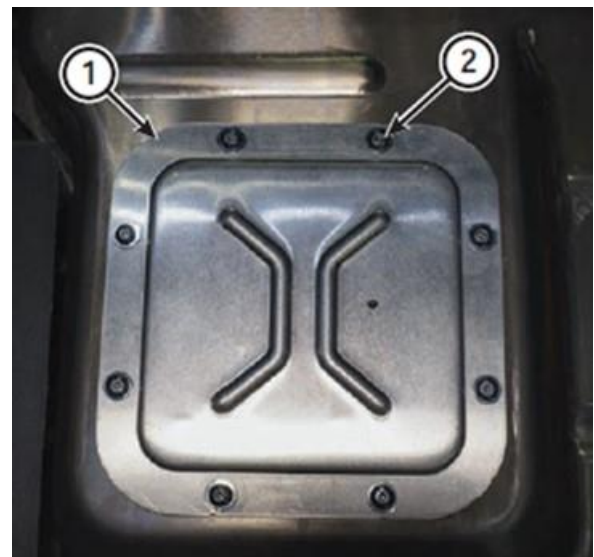

Figure 13 – Test Point Access Cover

Strictly respect STELLANTIS Group safety, cleanliness, and environmental instructions for any vehicle service.
Document exclusively reserved for dealer information. Internal distribution to be ensured by dealer.
Reproduction forbidden without the written agreement of STELLANTIS Group.

(tdb)

SAFETY RECALL – NORTH AMERICA

High Voltage Battery Fuse



Reference: 53A / NHTSA 23V-303

FCA US LLC

17. Remove the cover, connect the negative battery cable to the IBS and tighten the fastener (1) to 10N·m (7 ft. lbs.) (Figure 14).
18. Install the F09 (5 amp) IDCM fuse (3) in the Power Distribution Center (PDC) (Figure 14).
19. Connect the IBS harness connector (2) (Figure 14).
20. Using the scan tool, delete any DTCs that may have set due to the IDCM fuse being removed.
21. Perform **Section D**. Install the Authorized Modifications Label.
 - If fuse did not require replacement, record on label "**Fuse Inspected**".
 - If fuse did require replacement, record on label "**Fuse Replaced**".
22. For California residents, complete **Section E**. Proof of Correction Form.
23. Return the vehicle to customer or inventory.

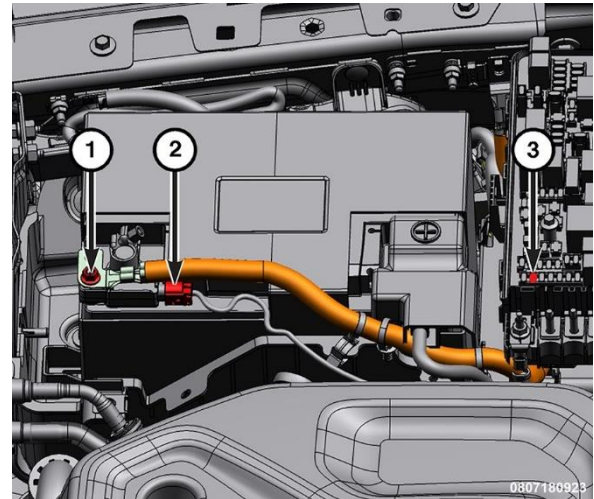

Figure 14 – Negative Battery Cable, Fuse F09 and IBS Connector

C. HV Battery Replacement

NOTE: Observe the following precautions when handling the HV battery pack:

- **DO NOT touch the high voltage terminals.**
- **Always use the battery pack four lift points when moving the battery pack.**
- **Keep the battery pack in an upright position.**
- **Store in a clean and dry environment.**
- **Store at a temperature of 10-30°C (50-86°F) with relative humidity between 30-70%.**
- **Always store at a State Of Charge (SOC) of around 30%.**
- **Always store on an electrically nonconducting (insulated) material.**
- **Store with spatial gap of at least 50 cm (20 in.).**
- **DO NOT store the battery pack near any environmental condition involving liquid, heat, strong magnetic field, electricity or that can generate heat (for example: transformers).**

NOTE: The HV battery pack weighs 167 kg (368 lb.).

NOTE: If the High Voltage (HV) battery is missing its return instructions, contact the UPS Call Center 800-567-9989.

1. Loosen the cap on the high voltage cooling reservoir.
2. Raise and support the vehicle.
3. Remove the eight push pin fasteners from the front air dam (1) (Figure 15).
4. Remove the bolts (2) (Figure 15).

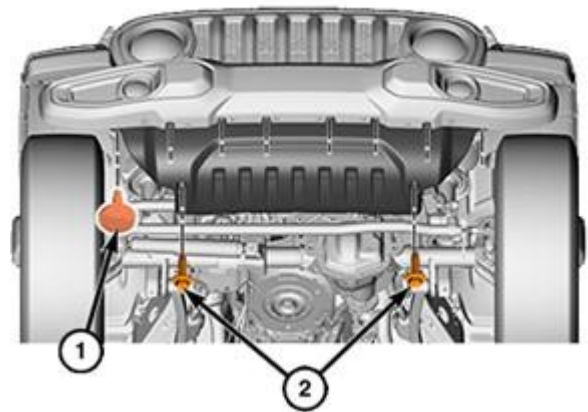

Figure 15 – Air Dam Fasteners

SAFETY RECALL – NORTH AMERICA
High Voltage Battery Fuse



Reference: 53A / NHTSA 23V-303

FCA US LLC

5. Remove the air dam (1) (Figure 16).
6. Remove the support and lower the vehicle.

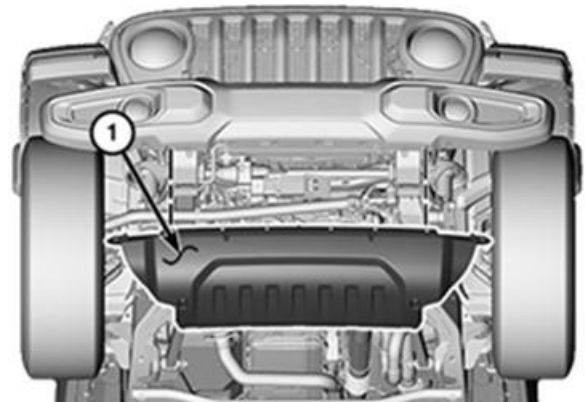

Figure 16 – Air Dam

7. Disconnect the vacuum boost hose quick coupling (1) from the air cleaner body cover (Figure 17).

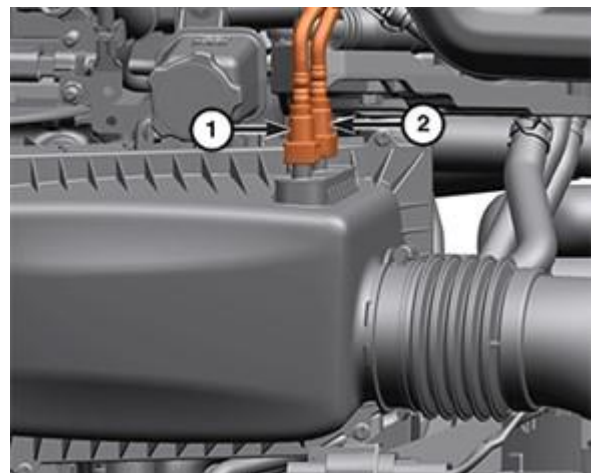

Figure 17 – Air Cleaner Cover

- Push in and hold both sides of the gray release (1) on the quick coupling (Figure 18).
- Pull the quick coupling away from air cleaner body cover.



Figure 18 – Hose Connections

Strictly respect STELLANTIS Group safety, cleanliness, and environmental instructions for any vehicle service.
Document exclusively reserved for dealer information. Internal distribution to be ensured by dealer.
Reproduction forbidden without the written agreement of STELLANTIS Group.

(tdb)

8. Disconnect the fuel vapor purge hose quick coupling (2) from the air cleaner body cover (Figure 17).

- Do not press on the green anti-tampering feature (1) (Figure 19).
- Push in and hold only the side of the release (2) with the green anti-tampering feature and pull the quick coupling away from air cleaner body cover.



Figure 19 – Hose Connections

9. Loosen the clean air hose band clamp (2) (Figure 20).

10. Remove the bolt (3) (Figure 20).

11. Disengaging the air cleaner body (1) from the two lower rubber grommets and from the clean air hose (Figure 20).

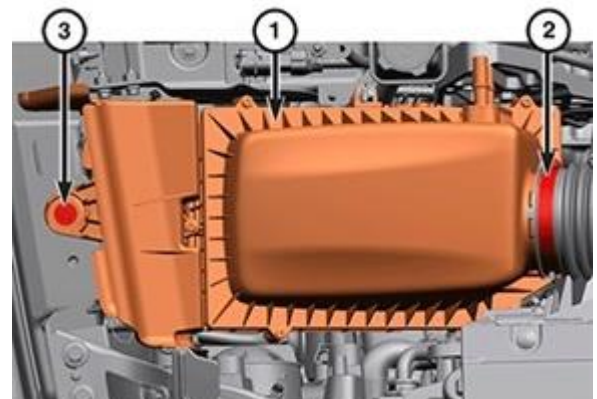

Figure 20 – Air Cleaner

SAFETY RECALL – NORTH AMERICA
High Voltage Battery Fuse

Reference: 53A / NHTSA 23V-303



FCA US LLC

12. Raise and support the vehicle.
13. Position a drain pan under the coolant hoses (Figure 21).
14. Remove the coolant hoses from the coolant line and drain the power electronics cooling system (Figure 21).
15. Once the system is completely drained, reinstall the coolant hose to the coolant line (Figure 21).

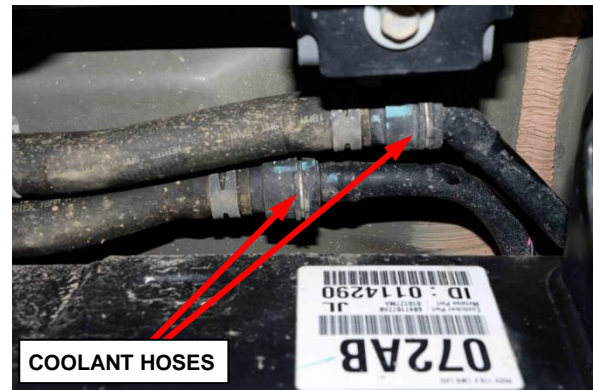

Figure 21 – Coolant Hoses

16. Remove the fasteners (1) and the skid plate (2) from the vehicle (Figure 22).

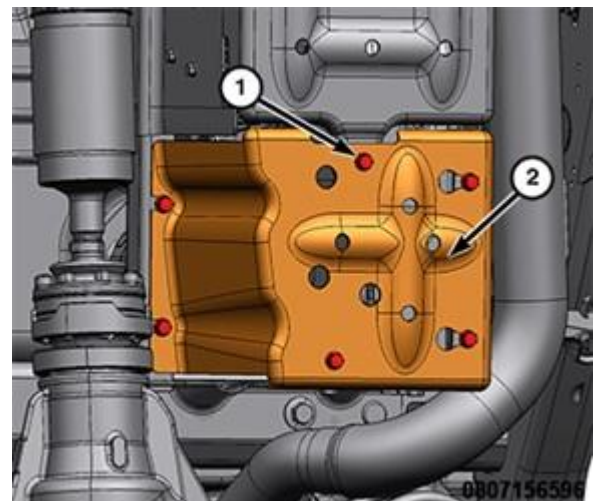

Figure 22 – Skid Plate

SAFETY RECALL – NORTH AMERICA
High Voltage Battery Fuse



Reference: 53A / NHTSA 23V-303

FCA US LLC

- 17. Disconnect the HV wire harness connectors (1) and (2) from the HV battery (Figure 23).

- 18. Cap the HV cables using Covers, HEV Battery Terminal 2035100082.

NOTE: A Plug-in Hybrid Electric Vehicle (PHEV) HV Battery Cover/Plug Kit is also available from Mopar® Parts.

- 19. Remove the support and lower the vehicle.

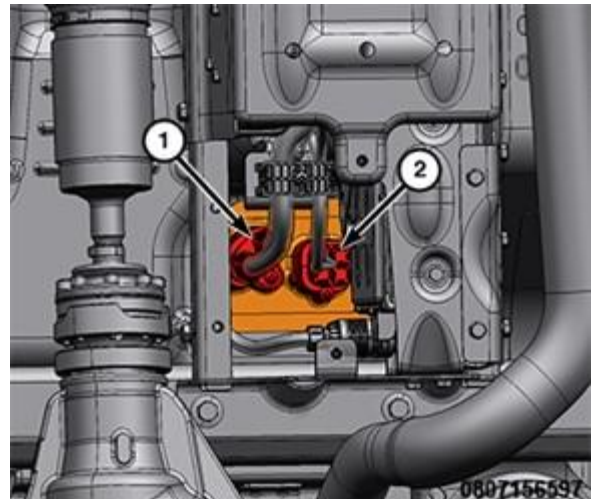

Figure 23 – HV Battery Wiring Connectors

- 20. Using a trim stick, release and remove the B-pillar trim cover (1) (Figure 24).



Figure 24 – B-pillar Trim Cover

21. Disconnect the wire harness connector (2) and release the door tether from the support bracket (1) (Figure 25).



Figure 25 – Harness to Support Bracket

22. Remove the bolt (2) securing the door check (1) (Figure 26).

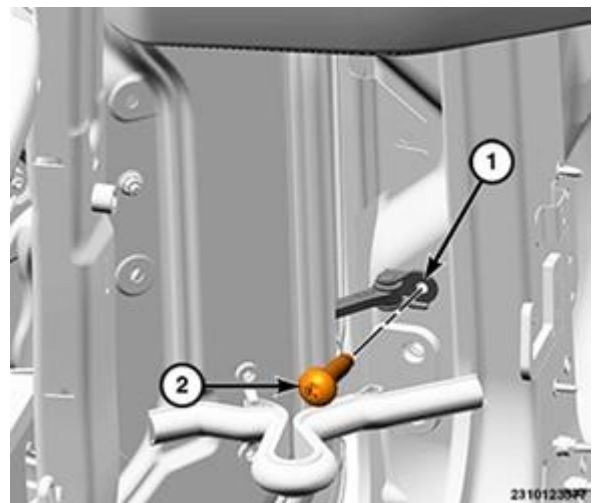

Figure 26 – Door Check Bolt

SAFETY RECALL – NORTH AMERICA
High Voltage Battery Fuse

Reference: 53A / NHTSA 23V-303



FCA US LLC

- 23. Remove the nuts (3) and lift the door up off hinges (1) and remove (Figure 27).
- 24. Raise the rear seat cushion.

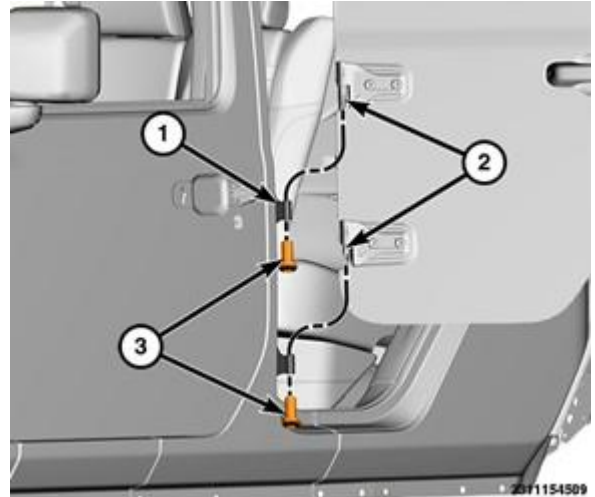

Figure 27 – Hinge Pin Nuts

- 25. Remove the fasteners (1) from the side high voltage battery trim panels (2) (Figure 28).
- 26. Using a trim stick or equivalent, remove the high voltage trim panel upward to release the retainers and remove the trim panel. Repeat for the passenger side.
- 27. Lower the rear seat cushion.

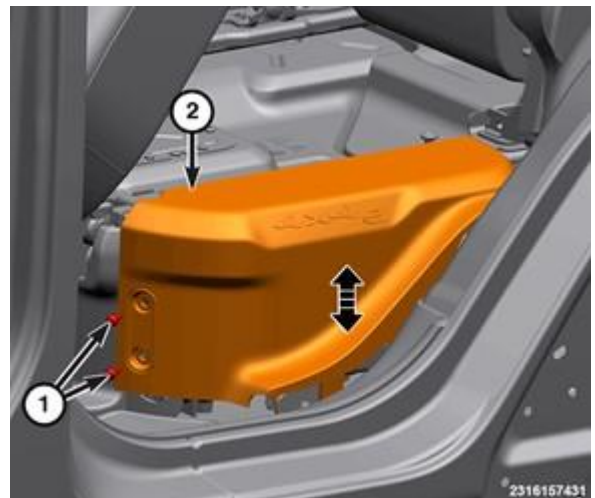

Figure 28 – HV Battery Side Trim

SAFETY RECALL – NORTH AMERICA
High Voltage Battery Fuse



Reference: 53A / NHTSA 23V-303

FCA US LLC

28. Using a trim stick or equivalent, release the retainers from the front high voltage battery closeout and remove from vehicle (Figure 29).

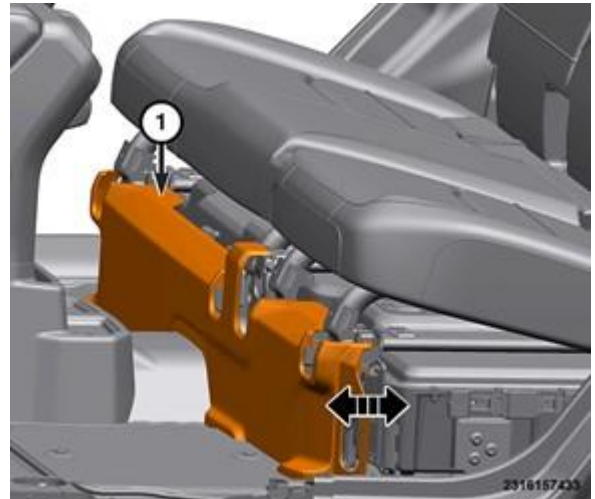

Figure 29 – HV Battery Front Trim

29. Remove the rear seat to load floor gap hider (Figure 30).



Figure 30 – Gap Hider

- 30. Disconnect the wire harness connectors, if equipped (4) (Figure 31).
- 31. Remove the nut for the center seat belt anchor (6). Remove the seat belts from the floor stud (Figure 31).
- 32. Remove the rear seat fasteners (2) at the rear of the seat (Figure 31).

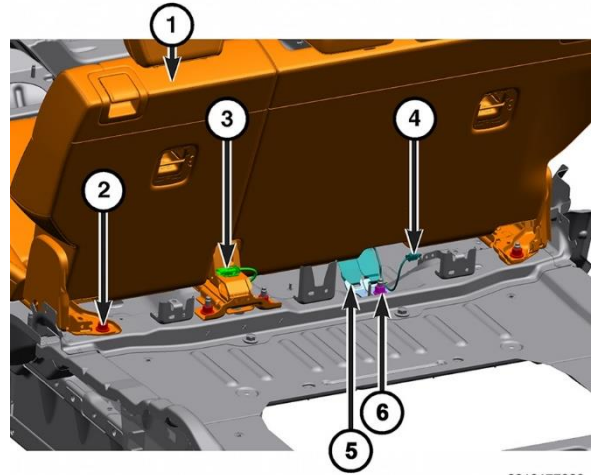

2319177336

Figure 31 – Rear Seat Components

- | | |
|----------------------------|---------------------------------|
| 1 - Rear Seat | 4 - Wire Harness Connector |
| 2 - Rear Seat Nuts | 5 - Seat Belts |
| 3 - Wire Harness Connector | 6 - Center Seat Belt Anchor nut |

- 33. Disconnect the wire harness connectors (3), if equipped (Figure 32).
- 34. Remove the bolts (1) at the front of the rear seat (Figure 32).

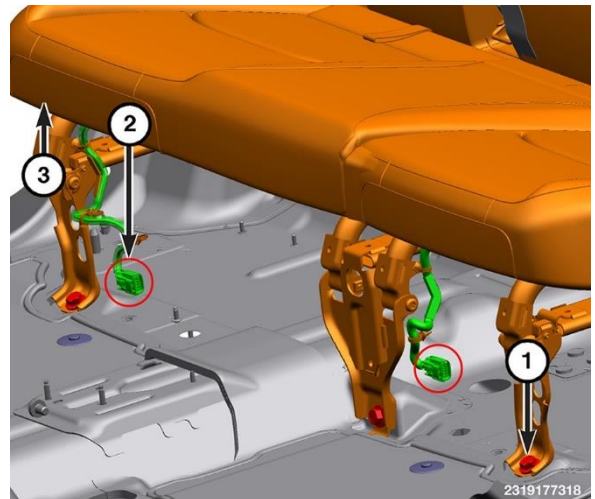

2319177318

Figure 32 – Rear Seat Components

- 1 - Rear Seat Bolts
- 2 - Wire Harness Connectors
- 3 - Rear Seat

SAFETY RECALL – NORTH AMERICA
High Voltage Battery Fuse

Reference: 53A / NHTSA 23V-303



FCA US LLC

- 35. Remove silencer pad (Figure 33).
- 36. Remove the seat from the vehicle.

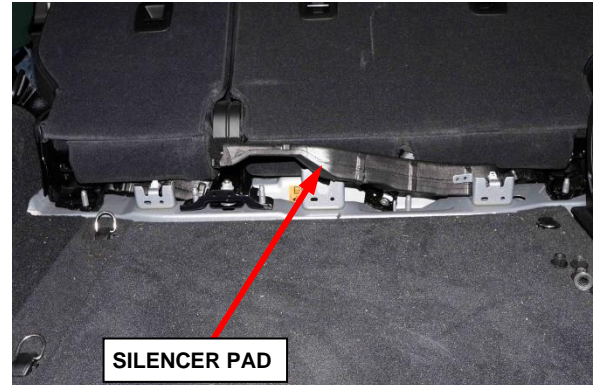

Figure 33 – Silencer Pad

- 37. Remove the fastener (1) and the chassis ground cable from the HV battery (2) (Figure 34).

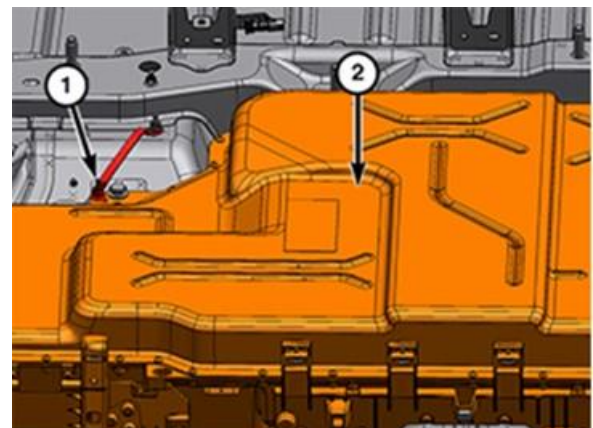

Figure 34 – HV Battery Fastener and Ground Cable

38. Disconnect the HV wire harness connectors (1) (Figure 35).

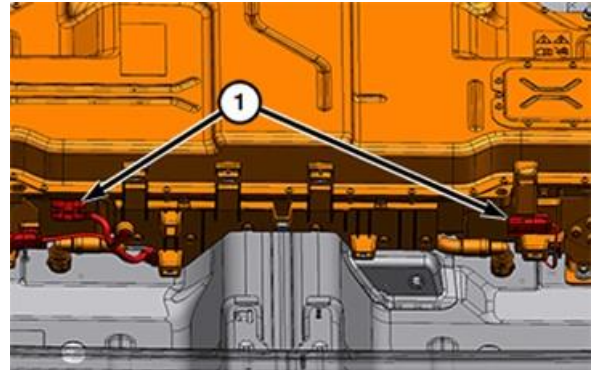

Figure 35 – HV Wire Harness Connectors

NOTE: Use an absorbent pad to collect any coolant that may leak from the battery into the interior of the vehicle.

39. Disconnect and plug the HV battery coolant line connectors (1) (Figure 36).

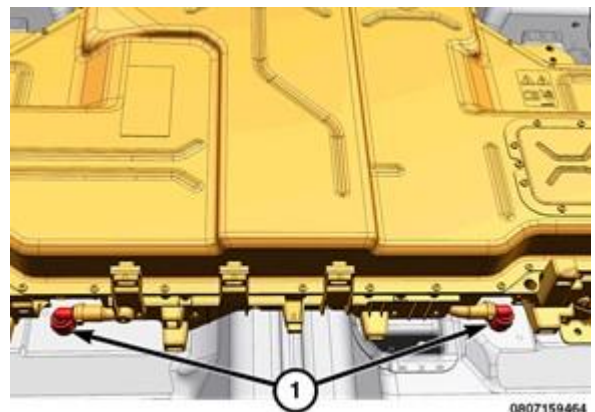

Figure 36 – HV Battery Coolant Connectors

NOTE: The HV battery pack weighs 167 kg (368 lb.).

40. Remove the bolts (1) securing the HV battery to the vehicle (Figure 37).

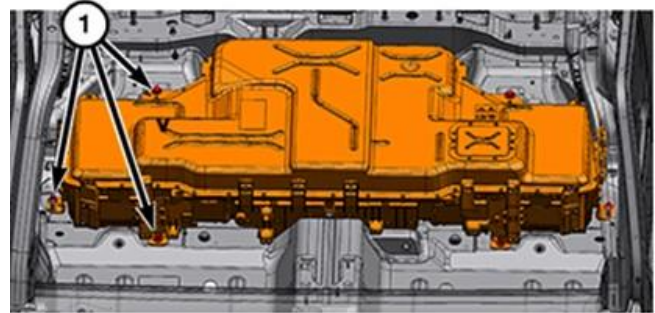

Figure 37 – HV Battery Bolts

41. Install two Eyebolt, 10mm 2035203080 with the nuts to the front support mounting holes (1) (Figure 38).

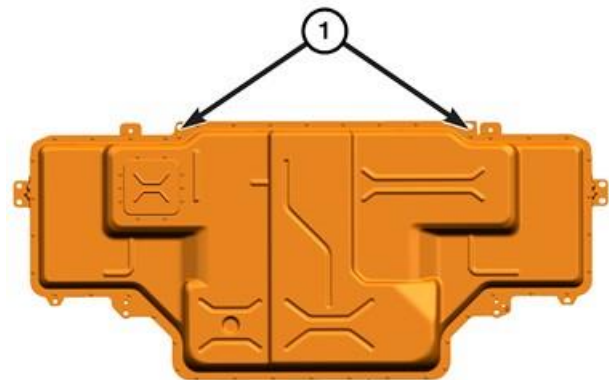

Figure 38 – Support Mounting Holes

42. Thread the other two Eyebolt, 10mm 2035203080 (1) into the threaded holes next to the HV battery pack mounting bolt holes (2) on the rear side of the HV battery pack (Figure 39).

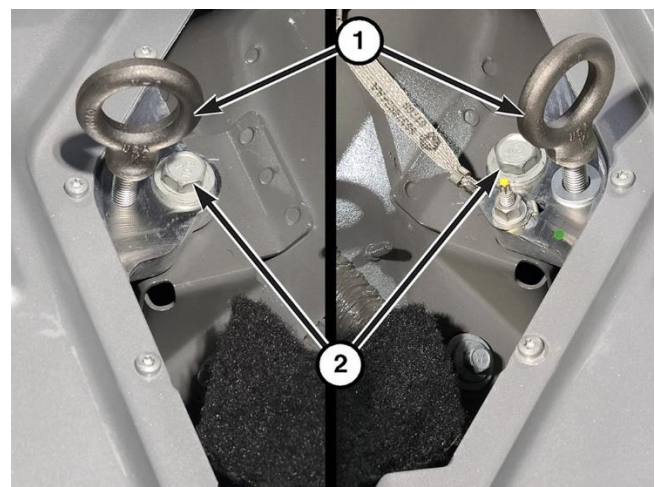

Figure 39 – Eyebolt Installation

SAFETY RECALL – NORTH AMERICA
High Voltage Battery Fuse



Reference: 53A / NHTSA 23V-303

FCA US LLC

43. Connect the Lift Straps, HV Battery 2035200080 to the eyebolts and the lifting device. Adjust the straps so that the battery will be level during lifting as shown in the picture (Figure 40).
44. Remove the HV battery pack from the vehicle.



Figure 40 – Lift Straps

NOTE: When the HV battery pack is being replaced:

- Refer to the information supplied with the **NEW** battery.
- All coolant must be removed from the battery. Use a shop air supply hose connected to the battery coolant inlet port. Adjust the air pressure regulator to not exceed 100 kPa (15 psi) and force the coolant from the battery coolant outlet port.
- All coolant ports and electrical connections must be capped.
- Place the HV battery pack in the shipping container or in a suitable storage location properly supported to prevent damage to the underside of the battery.

24. Attach the Eyebolt, 10mm 2035203080 to the new HV battery pack in the same locations that were used for the removal. Connect the Lift Straps, HV Battery 2035200080 on the front and rear eyelets.
25. Secure the HV battery pack to the lifting device.
26. Install the HV battery pack in the vehicle making sure that the mounting holes align with the bolt holes in the body.
27. Remove the lifting strap and eyebolts.
28. Install the HV battery pack bolts (1) and tighten to (Figure 37):
 - High Voltage Battery to Chassis M10 Bolts tighten to 45N·m (33 ft. lbs.).
 - High Voltage Battery to Chassis M8 Bolts tighten to 21N·m (15 ft. lbs.).
29. Install the chassis ground cable to the HV battery ground stud (1) and tighten to 9N·m (80 in. lbs.) (Figure 36).
30. Connect the HV battery coolant line connectors (1) (Figure 35).
31. Connect the three HV wire harness connectors (1) (Figure 34).
32. Install the silencer pad (Figure 33).
33. Install the rear seat to the vehicle.
34. Install the bolts at the front of the rear seat and tighten to 70N·m (52 ft. lbs.).
35. Connect the wire harness connectors, if equipped (Figures 31 and 32).
36. Install the rear seat fasteners at the rear of the seat and tighten to 70N·m (52 ft. lbs.).
37. Install the seat belts from the floor stud.

38. Install the nut for the center seat belt anchor and tighten to 70N·m (52 ft. lbs.).
 39. Raise the rear seat cushion.
 40. Install the rear seat to load floor gap hider.
 41. Align and install the retainers from the front high voltage battery closeout to the vehicle (Figure 29).
 42. Install the high voltage trim panel and press downward to seat the retainers (Figure 28).
 43. Install the fasteners to the side high voltage battery trim panels and tighten securely.
 44. Lower the rear seat cushion.
 45. Set the door into place on the hinges and install the door hinge pivot nuts. Tighten the nuts to 6N·m (53 in. lbs.) (Figure 27).
 46. Install the door check strap bolt securing the door check and tighten to 9N·m (80 in. lbs.) (Figure 26).
 47. Connect the wire harness connector and secure the door tether to the support bracket (Figure 25).
 48. Align and install the B-pillar trim cover (Figure 24).
 49. Raise and support the vehicle.
- NOTE: When connecting the High Voltage connection verify that the connectors are clean and seated properly.**
50. Remove the battery port covers and transfer them to the old battery. Connect the HV wire harness connectors (1) and (2) to the HV battery and tighten to 9N·m (80 in. lbs.) (Figure 23).

SAFETY RECALL – NORTH AMERICA
High Voltage Battery Fuse



Reference: 53A / NHTSA 23V-303

FCA US LLC

51. Install the battery skid plate (2) and tighten the fasteners (1) to 25N·m (18 ft. lbs.)
52. Remove the support and lower vehicle.

WARNING: ANTIFREEZE COOLANT IS HARMFUL IF SWALLOWED OR INHALED. IF SWALLOWED, DRINK TWO GLASSES OF WATER AND INDUCE VOMITING. IF INHALED, MOVE TO FRESH AIR AREA. SEEK MEDICAL ATTENTION IMMEDIATELY. DO NOT STORE IN OPEN OR UNMARKED CONTAINERS. WASH SKIN AND CLOTHING THOROUGHLY AFTER COMING IN CONTACT WITH ETHYLENE GLYCOL. KEEP OUT OF REACH OF CHILDREN. DISPOSE OF GLYCOL BASED COOLANT PROPERLY. CONTACT YOUR DEALER OR GOVERNMENT AGENCY FOR LOCATION OF COLLECTION CENTER IN YOUR AREA. DO NOT OPEN A COOLING SYSTEM WHEN THE ENGINE IS AT OPERATING TEMPERATURE OR HOT UNDER PRESSURE; PERSONAL INJURY CAN RESULT. AVOID RADIATOR COOLING FAN AND OTHER MOVING COMPONENTS WHEN ENGINE COMPARTMENT RELATED SERVICE IS PERFORMED; PERSONAL INJURY CAN RESULT.

WARNING: WEAR APPROPRIATE EYE AND HAND PROTECTION WHEN PERFORMING THIS PROCEDURE.

53. Fill the battery cooling system.

NOTE: Fill the High Voltage (HV) battery cooling system with the recommended MOPAR Antifreeze Coolant (Refer to 04 - Vehicle Quick Reference/Capacities and Recommended Fluids/Specifications in Service Library).

54. Power up the HV battery system.

NOTE: When performing any repairs that involve contact with high voltage components or systems, the technician performing repairs on the vehicle must verify that the system remains powered down during high voltage repairs.

- This must be done by removing the test points access cover.
- The high voltage power down procedure must also be performed to ensure that the vehicle is properly powered down.
- The technician must know the whereabouts of the test points access cover throughout the repair.
- The technician must ensure that no one reinstalls the test points access cover while service is being performed.
- The technician must recheck that the test points access cover has not been reinstalled in cases where the vehicle was unattended.

55. Use of an insulation tester such as the Fluke Meter, Multi 126-1587 is recommended for Plug-In Hybrid Electric Vehicle (PHEV) circuit testing. Perform the multi-meter functionality tests per the manufacturer's directions. Verify the multi-meter is operating correctly by measuring voltage from a known good power source, such as the vehicle's 12-volt battery. If at any point during the procedure, the multi-meter settings are changed, or the probes are repositioned in the meter, verification with a known good power source must be repeated.

SAFETY RECALL – NORTH AMERICA

High Voltage Battery Fuse



Reference: 53A / NHTSA 23V-303

FCA US LLC

- 56. Remove the M6 Torx screws from the high voltage service test points access cover (Figure 41).
- 57. Carefully remove the test points access cover and set in a protected location such that the cover plate alignment and HVIL pins are not damaged (Figure 41).

NOTE: Lift the cover straight up to avoid bending or damaging the pin on the cover that is used to engage the HVIL switch.

NOTE: Always observe these precautions prior to taking an isolation resistance measurement:

- Have known good test leads
- Set the test voltage to 500 Volts
- Always wear safety glasses

- 58. Using the Meter, Multi 126-1587 measure and record the isolation resistance between the high voltage positive test point and chassis ground (Figure 42).

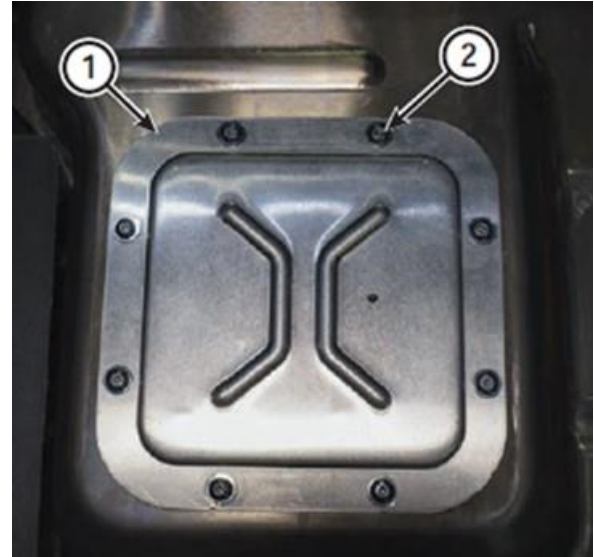

Figure 41 – Test Point Access Cover



Figure 42 – Measure and Record Isolation Resistance Between HV Positive Test Point and Chassis Ground

- 59. Using the Meter, Multi 126-1587 measure and record the isolation resistance between the high voltage negative test point and chassis ground (Figure 43).
- 60. Isolation resistance should be 2.3 Mohms (+/- .2). If the measured isolation resistance is outside of this range, a loss of isolation condition exists within the high voltage circuitry. **Do not continue the High Voltage Power Up procedure until the condition causing the loss of isolation is corrected.**



Figure 43 – Measure and Record Isolation Resistance Between HV Negative Test Point and Chassis Ground

- 61. If required, remove the lockout-tagout padlock from the service lockout loop (1) (Figure 44).



Figure 44 – Service Lockout Loop

62. Install the test points access cover (1) to the battery pack and securely tighten the eight M6 Torx screws (2), identified with blue circles (Figure 44).
63. Remove the cover, connect the negative battery cable to the IBS and tighten the fastener (1) to 10N·m (7 ft. lbs.) (Figure 45).
64. Install the F09 (5 amp) IDCM fuse (3) in the Power Distribution Center (PDC) (Figure 45).
65. Connect the IBS harness connector (2) (Figure 45).
66. Using the scan tool, delete any DTCs that may have set due to the IDCM fuse being removed. Turn the key OFF and wait 2 minutes,
67. Use the scan tool and flash program the BPCM with the latest software.
68. Use the scan tool and perform the “Enable Contactor for Service” procedure in BPCM.

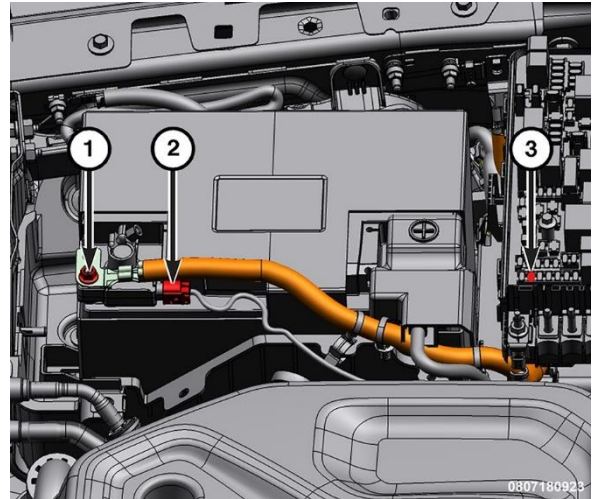

Figure 45 – Negative Battery Cable, Fuse F09 and IBS Connector

NOTE: If these procedures are not performed, the vehicle will not start. The high voltage battery pack is shipped with the contactors locked in the open position for safety concerns. Until these routines are performed, the battery pack contactors will not close resulting in a no start condition.

69. Close the hood, press the START button and verify that the Hybrid Status Indicator is green and no warnings are displayed.

FILL AND BLEED USING THE SCAN TOOL (PREFERRED)

- a) Fill the HV battery pressurized coolant bottle to the max level.
- b) Cycle the ignition to the on position.
- c) With the scan tool, run the “Coolant Fill Procedure” routine in the Hybrid Control Processor (HCP). This should run all of the coolant pumps in all cooling systems.
- d) Continue adding coolant to the HV battery pressurized coolant bottle maintaining the coolant at the max level.
- e) When no more coolant is needed the system is filled and bled. The routine may time out before the system is full and take multiple cycles to bleed all of the air from the system.
- f) Stop the scan tool actuation. Fill the bottle slightly above the fill line in case of any air trapped in the system.

FILL AND BLEED WITHOUT THE SCAN TOOL

- a) Fill the HV battery pressurized coolant bottle to the max level.
- b) Cycle the key to the on position to power the battery coolant pump in order to fill and bleed the HV cooling system.
- c) Cycle the key to the off position after the pump times out and stops running.
- d) Fill the HV battery pressurized coolant bottle to the max level.
- e) Repeat the fill procedure until the proper coolant level is achieved. Fill the bottle slightly above the fill line in case of any air trapped in the system.

70. Perform **Section D**. Install the Authorized Modifications Label.
 - If battery require replacement, record on label “**Battery Replaced**”.
71. For California residents, complete **Section E**. Proof of Correction Form.
72. Return the vehicle to the customer or inventory.

D. Install the Authorized Modifications Label

Type or print (with a ballpoint pen) the necessary information shown in Figure 46 onto the Authorized Modifications Label. Then attach the label near the VECI label.

Chrysler Group LLC	AUTHORIZED MODIFICATIONS	THESE MODIFICATIONS HAVE BEEN APPROVED AS APPROPRIATE BY EPA AND CARB.
THE FOLLOWING MODIFICATIONS HAVE BEEN MADE:		
RECORD IN THIS AREA THE RECALL NUMBER AND IF THE FUSE WAS INSPECTED OR IF THE FUSE OR THE BATTERY WERE REPLACED		
CHANGE AUTHORITY	DEALER CODE	DATE
RECALL	XXXXX	XX / XX / XXXX
04275086AD		

E. Complete Proof of Correction Form for California Residents

This recall is subject to the **State of California Registration Renewal/Emissions Recall Enforcement Program**. Complete a Vehicle Emission Recall Proof of Correction Form (**Form No. 81-016-1053**) and **supply it to vehicle owners residing in the state of California** for proof that this recall has been performed when they renew the vehicle registration.

Process Steps to obtain the California Proof of Correction form:

- a. Access the “**DealerCONNECT**” website.
- b. Select the “**Service**” tab.
- c. Under the “**Publications**” heading, select the “**ePublishing**” link.
- d. Sign in using your **Dealer Code** and **Password**.
- e. Select the “**Proof of Correction form**”.