



SAFETY RECALL

Release Date: March 3, 2023

SLI

Communication #: T-23-01

Model Year(s): 2022–2023

— Confidential and Proprietary —

VERSION: R02 (March 16, 2023)

Added Notice box to Purpose

Updated Affected Service Parts section

IMPORTANT STOP SALE SAFETY NOTICE!

Stop selling affected vehicles immediately until the repair procedure has been completed on affected units at your dealership. Federal law prohibits the sale of products subject to a recall. Selling such products could subject the seller to substantial penalties.

IMPORTANT

If you are working with a printed copy, please verify you have the most current version of this document.

SUBJECT: ALTERNATOR REPLACEMENT

PURPOSE

Polaris has determined that on some Model Year 2022-23 Slingshot vehicles, the alternator may have been improperly manufactured by the supplier and an internal rotor segment may crack and separate during operation, posing a fire hazard and risk of serious injury. The affected population is less than 100 vehicles.

To resolve this concern, Polaris has developed a procedure to replace the alternator on affected units.

NOTICE

All VINs shown affected in Unit Inquiry require alternator replacement.

AFFECTED MODELS

MODEL YEAR	MODELS	AFFECTED RANGE
2022	Slingshot R / S / SL / SLR	Reference Unit Inquiry on the dealer website or the Service Communications list on the STOP site to look up affected units.
2023	Slingshot R / S / SL	

The information contained within this document is confidential and protected by U.S. and international copyright laws, and is the property of Polaris Inc. This document is provided for the sole use of authorized Polaris dealers and distributors. This document is not to be distributed, duplicated, or copied, digitally or otherwise, without the written consent of Polaris Inc.

CUSTOMER NOTIFICATION

Dealers are required to review their sales records and make arrangements with customers for Recall completion. In addition to consumer units, dealers are required to correct any affected units in their inventory. Polaris will be mailing a notification letter to consumers affected by this Recall. Polaris will also send an email to owners for whom Polaris has a valid email address.

CONTACT POLARIS

If you have questions that are not addressed in this document or in the Safety Recall FAQ, contact Polaris Service through Ask Polaris or by phone at 1-855-863-2284 (US/Canada Dealers Only).

DEALER - WHAT TO DO?

As of March 3, 2023, **YOU MUST NOT SELL OR DELIVER** any **NEW OR USED Model Year 2022-2023 Slingshot vehicles** until it is repaired according to the **Safety Recall**.

Dealers are directed to inform affected consumers of the recall during any routine service repair and to implement the repair remedy.

REVISION INDEX

IMPORTANT

Please review the following table as important changes have been made to this Safety Recall.

REVISION	RELEASE DATE	UPDATES
R01	03/03/2023	Initial Safety Recall released.
R02	03/16/2023	Added Notice box to Purpose. Updated Affected Service Parts section.

AFFECTED SERVICE PARTS

NOTICE

The serial number inspection below is only for alternators ordered from Polaris prior to the release of this Recall. All VINs shown affected in Unit Inquiry require alternator replacement.

Dealers are required to review all current service parts inventory, past service parts sales, and past repair order information since February 2022 for affected alternators.

Dealer – What to do? Dealers must contact customers associated with sales and repairs orders above, and inspect the alternator for the following affected serial numbers. Dealers must also inspect service part inventory for alternators with an affected serial number, and file a Parts Stock Claim if still in inventory.

PART NUMBER	PART DESCRIPTION	SERIAL NUMBERS AFFECTED
4017547	ALTERNATOR-140AMP	Two affected serial numbers: 083220149, 090220058

ALTERNATOR SERIAL NUMBER LOCATION

Reference the **NINE DIGIT** serial number on the alternator.

If an alternator is found with an affected serial number and is installed on a vehicle:
Submit an Ask Polaris case under Service & Warranty Questions >> All Vehicle



WARRANTY CLAIM INFORMATION

2022-23 SLINGSHOT	
Bulletin #	T-23-01
Claim Type	SB (Service Bulletin)
Labor Allowance	0.6 hours (36 minutes)
Part Number / Description	4017547 (QTY 1) Alternator-140AMP 5416314 (QTY 1) Belt-Alt, Stretch
Parts Availability	Available starting the week of 3/13/2023
University of Polaris Video Training Required	NO

Claim Submission:

- **US / Canada Dealers:** On DEX, go to Service and Warranty > Warranty Claim and Extended Coverage > Start a New Warranty Claim. Select Service Bulletin> Enter the VIN / PIN and Retrieve Registration. Select T-23-01 and Send Claim.
- **International Dealers:** On iDEX, go to Service and Warranty> Warranty Claims>Start a New Warranty Claim. Select Service Bulletin> Enter the VIN / PIN and Retrieve Registration. Select T-23-01 and Send Claim

CLAIM SUBMISSION INFORMATION

REQUIRED ALTERNATOR SERIAL NUMBER	
<p>Record the NINE DIGIT serial numbers on the <i>NEW</i> alternator for warranty claims processing. Claims filing will not be permitted without the <i>NEW</i> alternator serial number.</p>	
<p>Enter the <i>NEW</i> alternator serial number when filing a claim.</p>	

The information contained within this document is confidential and protected by U.S. and international copyright laws, and is the property of Polaris Inc. This document is provided for the sole use of authorized Polaris dealers and distributors. This document is not to be distributed, duplicated, or copied, digitally or otherwise, without the written consent of Polaris Inc.

DECLINED SAFETY RECALL

Polaris provides a claim process that allows dealers to accurately document when a Safety Recall cannot be performed on a vehicle due to modification. Criteria and instructions can be found under Service & Warranty > STOP Site > News, Forms, & Links > Declined Safety Bulletin Tracking.

COVERAGE PERIOD

Coverage will begin on March 3, 2023. This bulletin has no expiration date.

PARTS RETURN / DISPOSAL INFORMATION

Under no circumstances shall the parts removed be re-used, sold, or re-purposed for another application. It is your dealership / distributor's responsibility to make sure every part replaced (related to this communication) is taken out of circulation and returned to Polaris.

FEEDBACK FORM

A feedback form has been created for the technician to provide Polaris with an overall satisfaction rating for the instructions, provide comments on your experience or upload pictures/video. The form is viewable on mobile devices by scanning the QR code or on a PC by clicking [HERE](#).



REPAIR OVERVIEW

In this procedure, the alternator will be replaced.

The following procedure steps are critical to a successful repair:

1. Disconnect and cover the negative battery cables/terminals on the primary and secondary (if equipped) battery.
2. The alternator uses a stretch belt that must be cut off, and a new one installed.
3. Do not damage the vehicle-side alternator electrical wiring when removing the alternator.
4. Upon repair completion, alternator charging voltage must be confirmed.

ALTERNATOR SERIAL NUMBERS

Polaris will be collecting the **NINE DIGIT** serial number from the new alternators.



REPAIR PROCEDURE

TOOLS REQUIRED

- Safety Glasses
- Socket Set, Metric
 - 10 mm, 13 mm, 19 mm
- Socket Set, Hex Bit, Metric
 - 6 mm
- Socket Set, SAE
 - 5/16 in
- Breaker Bar
- Torque Wrench
- Cutting Tool
- Electrical Tape
- **Special Service Tool:**
 - Stretch Belt Installation Tool: (commercially available, such as OEM Tools 24388, OTC 7425)



T-23-01 ALTERNATOR REPLACEMENT

GENERAL

1. Park vehicle on a flat surface.
2. Apply parking brake.
3. Press START/STOP button to turn vehicle OFF.
4. Remove key fob from proximity of vehicle.
5. Chock rear tire and open vehicle hood.
6. Loosen negative (-) battery terminal bolt and disconnect.

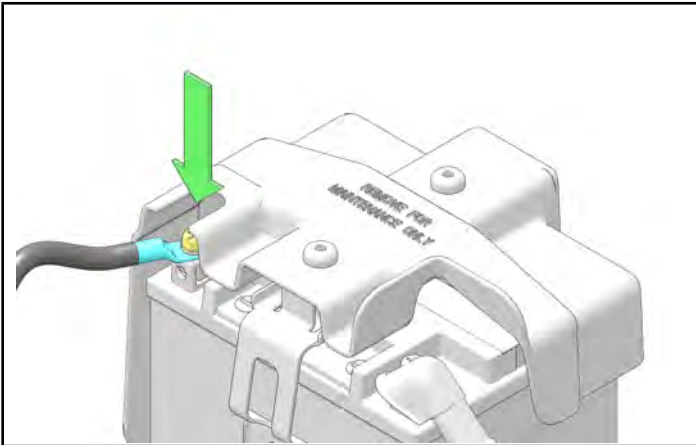

- b. Disconnect the breather tube ① from the intake air boot. Loosen worm clamp ② and remove the intake air boot along with the air box assembly.

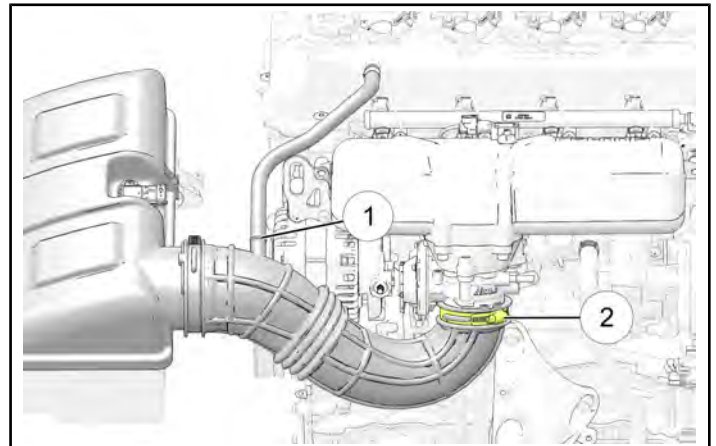

- c. Remove air box fasteners ③ and remove air box base.

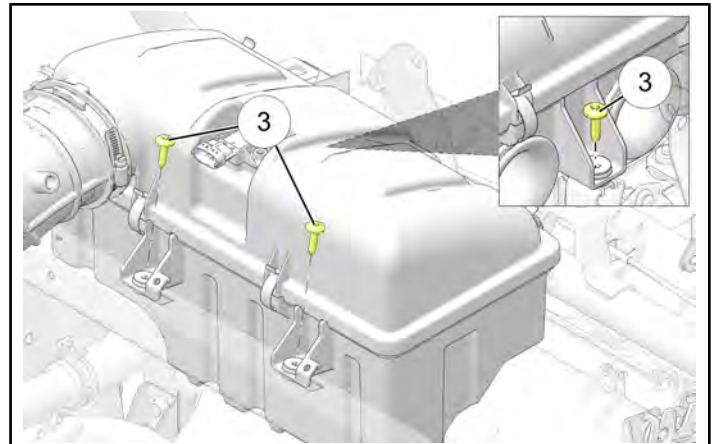

ALTERNATOR REMOVAL

1. Using compressed air, clean intake tube area around the throttle body.

NOTICE

A small amount of oil in the intake tube is normal and can be wiped out with a clean towel.

2. Remove Air Box:
 - a. Disconnect the TBAP electrical connector from the air box cover.

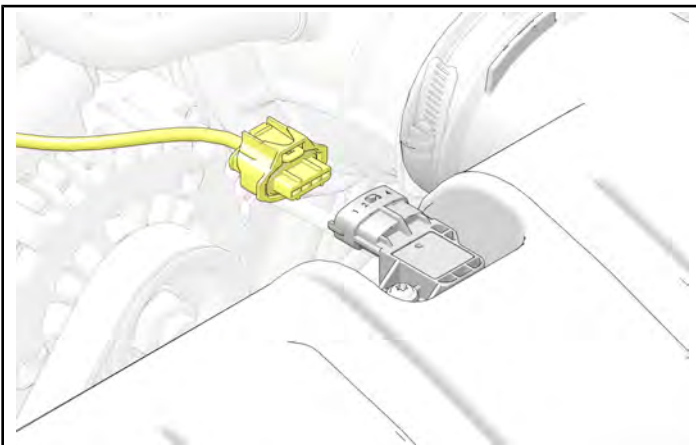

3. Remove positive terminal nut ③ and disconnect the main charging lead from the alternator.

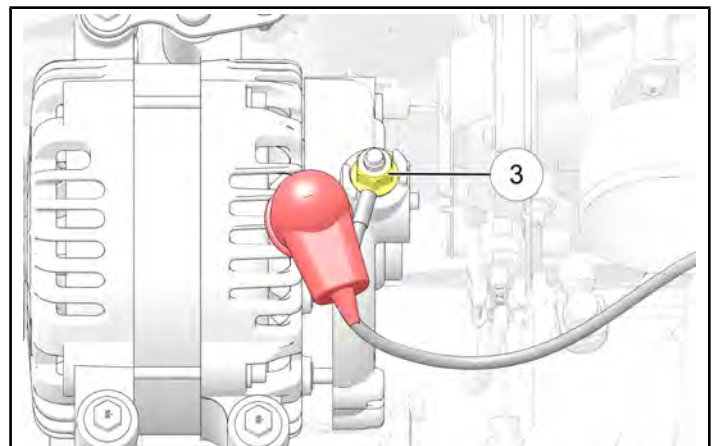

4. Disconnect the alternator electrical connector.

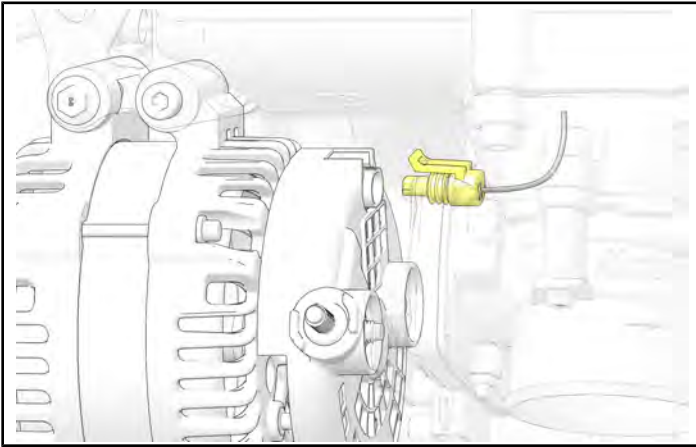

NOTICE

A 90 degree hose pick tool or similar can be used to assist in lifting the locking tab of the connector.

IMPORTANT

Use care not to damage the harness or connector during removal.

5. Cut the stretch belt and DISCARD.

6. Remove three bolts ④ securing the alternator to the engine block and three bolts ⑤ securing the alternator to the intake manifold. Remove the alternator.

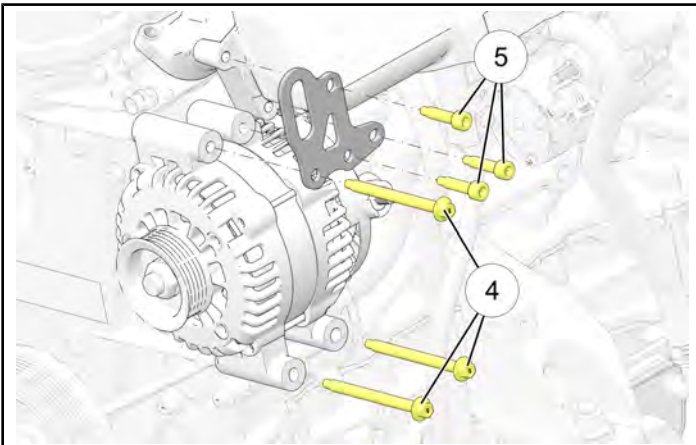

STOP!

Retain the alternator, as it will need to be returned through the parts recall process.

ALTERNATOR INSTALLATION

STOP!

Before installing the new alternator, record the **NINE DIGIT** serial number on back of the **NEW** alternator. The serial number will not be clearly visible once installed. The serial number is required for warranty claim submission.

XXXXXXXXXX



1. Install new alternator. Loosely install fasteners ④ and ⑤. Torque fasteners to specification in sequence shown.

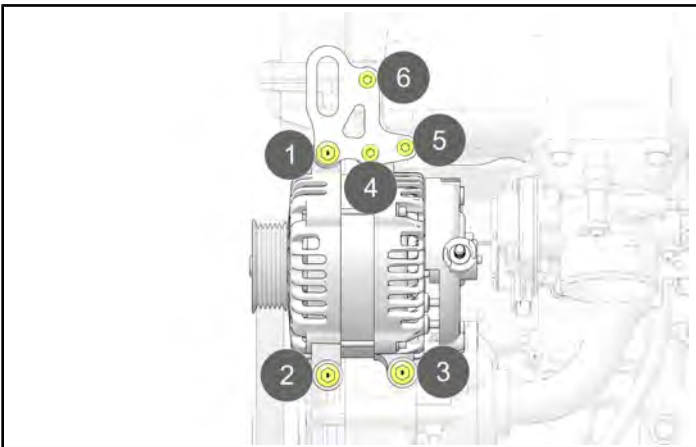
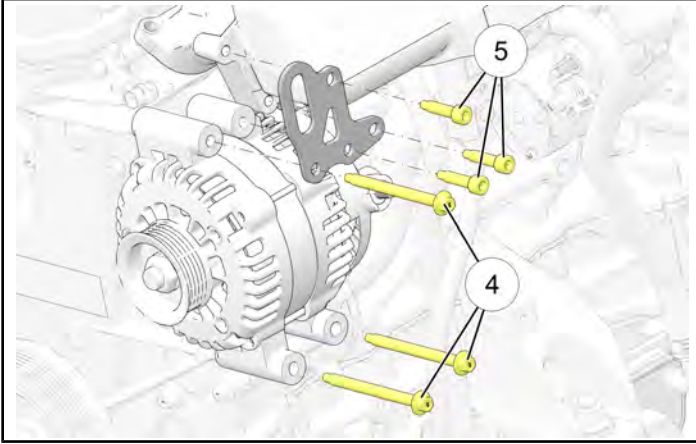

TORQUE

Alternator Mounting Fasteners:
16 ft-lbs (22 N·m)

2. Using a commercially-available stretch belt installation tool, install a NEW stretch belt over the alternator pulley and then onto the crankshaft pulley with the installation tool.

IMPORTANT

Harmonic damper pulley can be rotated using a 19 mm socket and a long ratchet on the harmonic damper bolt. The engine must only be rotated in the **CLOCKWISE** direction.

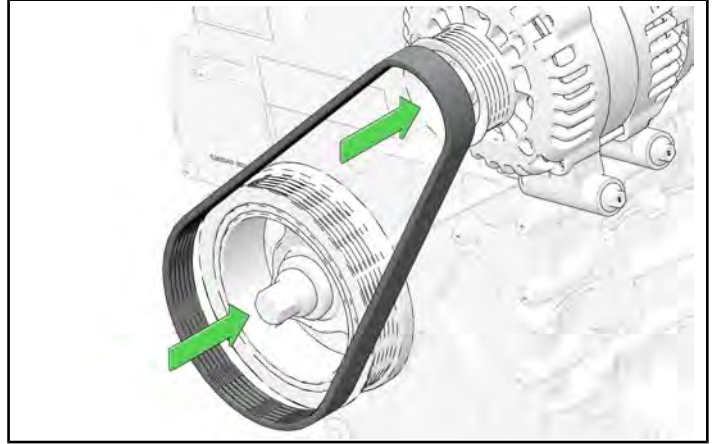

STOP!

Verify the belt is completely seated in the alternator and crankshaft pulleys.

3. Connect the alternator electrical connector.

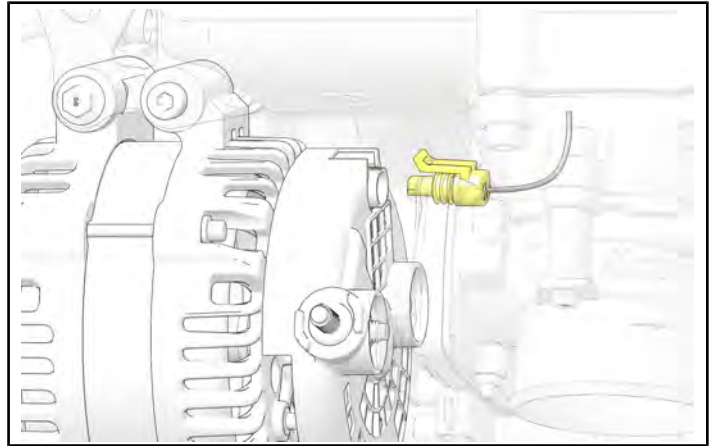

4. Install the main charging lead to the alternator. Install positive terminal nut ③ and torque to specification. Cover the terminal nut with the red protective cap.

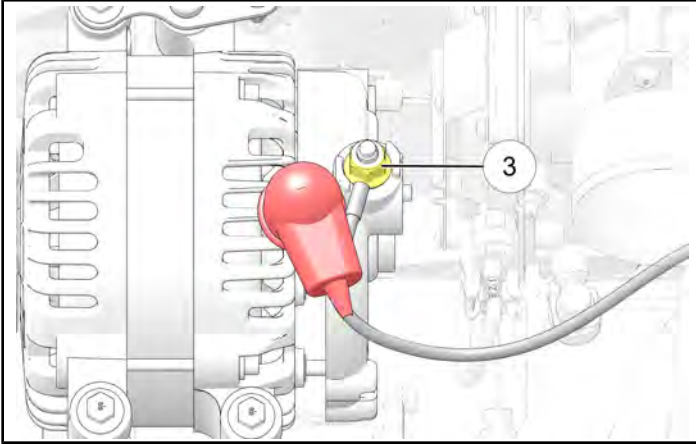

TORQUE

Alternator Terminal Nut:
84 in-lbs (9 N·m)

- b. Install the air box cover along with the intake air boot. Connect the breather tube ① to the intake air boot. Install the intake air boot to the intake manifold. Torque intake duct clamp ② to specification.

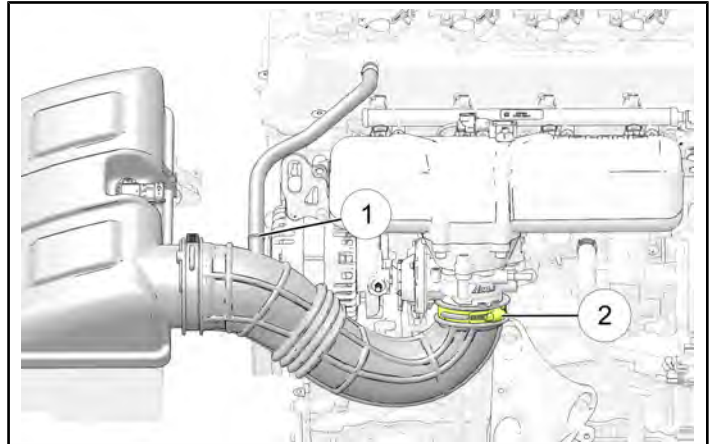

TORQUE

Intake Duct Clamps
35 in-lbs (4 N·m)

5. Install Air Box:

- a. Install air box base and fasteners ③. Torque fasteners to specification.

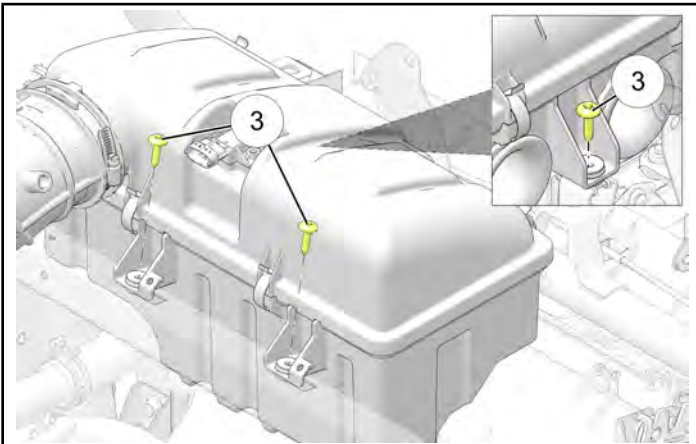

TORQUE

Airbox Fasteners
89 in-lbs (10 N·m)

- c. Connect the TBAP electrical connector to the air box cover.

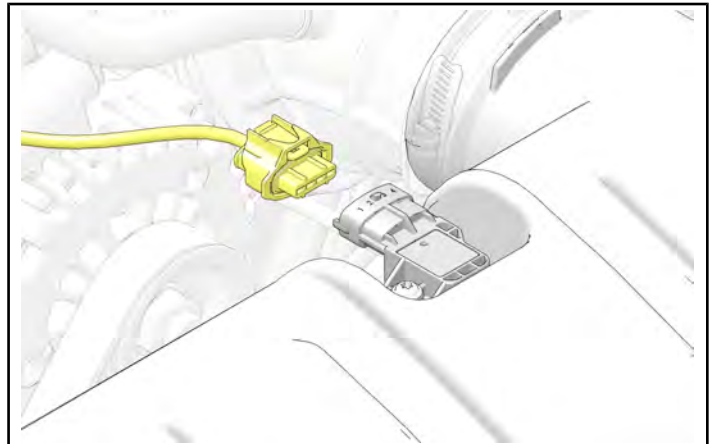

6. Install negative (-) cable to the battery and torque terminal bolt to specification.

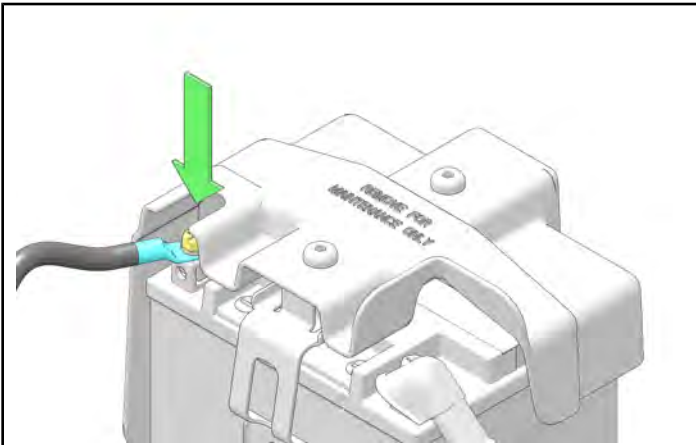

TORQUE

Negative Battery Terminal:
40 in-lbs (4.5 N·m)

7. Turn the key to the ON position, start the engine, and make sure that the vehicle powers up properly. In the gauge, verify that the battery voltage is greater than 14 Volts. Make sure there are no MILs or warning lights illuminated.
8. Submit a Service Bulletin Warranty Claim for T-23-01.