

Compliance Recall

Code: 69ET



Subject	Passenger Frontal Airbag																									
Release Date	April 14, 2023																									
Affected Vehicles	<table border="1"><thead><tr><th>Country</th><th>Beginning Model Year</th><th>Ending Model Year</th><th>Vehicle</th><th>Vehicle Count</th></tr></thead><tbody><tr><td>USA</td><td>2022</td><td>2023</td><td>A8</td><td>692</td></tr><tr><td>USA</td><td>2022</td><td>2023</td><td>S8</td><td>355</td></tr><tr><td>CAN</td><td>2022</td><td>2023</td><td>A8</td><td>38</td></tr><tr><td>CAN</td><td>2022</td><td>2023</td><td>S8</td><td>40</td></tr></tbody></table> <p>Check Campaigns/Actions screen in Elsa on the day of repair to verify that a VIN qualifies for repair under this action. Elsa is the <u>only</u> valid campaign inquiry & verification source.</p> <ul style="list-style-type: none">✓ Campaign status must show "open."✓ If Elsa shows other open action(s), inform your customer so that the work can also be completed at the same time the vehicle is in the workshop for this campaign.	Country	Beginning Model Year	Ending Model Year	Vehicle	Vehicle Count	USA	2022	2023	A8	692	USA	2022	2023	S8	355	CAN	2022	2023	A8	38	CAN	2022	2023	S8	40
Country	Beginning Model Year	Ending Model Year	Vehicle	Vehicle Count																						
USA	2022	2023	A8	692																						
USA	2022	2023	S8	355																						
CAN	2022	2023	A8	38																						
CAN	2022	2023	S8	40																						
Problem Description	<p>The occupant protection flap of the airbag within the passenger airbag module may not have been folded as specified. Because of this, the vehicles included in this recall may not fully comply with the requirements of an out of position airbag test according to FMVSS 208 & CMVSS 208, "Occupant Crash Protection".</p> <p>The airbag in the affected vehicles is fully functional. However, if a child or small person was seated and unbelted on the front passenger seat and very close to the instrument panel, in a crash the force caused by the inflating airbag on the occupant could be higher than permitted, increasing the risk of injury.</p>																									
Corrective Action	Replace the front passenger airbag.																									
Code Visibility	On February 23, 2023, the campaign code was applied to affected vehicles.																									
Owner Notification	Owner notification will take place in April 2023. Owner letter examples are included in this bulletin for your reference.																									
Additional Information	<p>Please alert everyone in your dealership about this action, including Sales, Service, Parts and Accounting personnel. Contact Warranty if you have any questions.</p> <p>IMPORTANT REMINDER ON VEHICLES AFFECTED BY SAFETY & COMPLIANCE RECALLS</p> <p><u>New Vehicles in Dealer Inventory:</u> It is a violation of federal law for a dealer to deliver a new motor vehicle or any new or used item of motor vehicle equipment (including a tire) covered by this notification under a sale or lease until the defect or noncompliance is remedied. By law, dealers must correct, prior to delivery for sale or lease, any vehicle that fails to comply with an applicable Federal Motor Vehicle Safety Standard or that contains a defect relating to motor vehicle safety.</p> <p><u>Pre-Owned Vehicles in Dealer Inventory:</u> Dealers should not deliver any pre-owned vehicles in their inventory which are involved in a safety or compliance recall until the defect has been remedied.</p> <p>Dealers must ensure that every affected inventory vehicle has this campaign completed <u>before</u> delivery to consumers.</p>																									

Parts Information

Parts Control Type: VIN to Order	If parts are needed to support a vehicle repair: <ul style="list-style-type: none"> • US Dealers - use AVA • CAN Dealers - contact the Parts Specialists via phone (800-767-6552), email (VWoAPartsSpecialists@vw.com), or chat/text with the VIN to order
---	--

Parts Control Type: Free Order	Parts will be managed by Free Order
---	-------------------------------------

Initial Allocation: NO	There will be no parts allocation. Please reference the Repair Projection Tool (below) to view your potential VIN population.
---	---

Repair Projection Tool: (right click to open)	
--	---

Criteria	Quantity	Part Number	P.O.C. Part Description	Ordering Method
4N	1	4N0-880-204-H	AIRBAG	VIN to Order
	4	N -910-935-02	BOLT	Free Order

NOTE

The specified part numbers reflect the status at the start of this action. Interim updates made in ETKA can cause a listed part number to become unavailable. In this case, the new part number specified in ETKA should be used.

Claim Entry Instructions

The labor times listed here may differ from the labor operations and labor times listed in ELSA.

After campaign has been completed, enter claim as soon as possible to help prevent work from being duplicated elsewhere. Attach the Elsa screen print showing action open on the day of repair to the repair order.

If customer refused campaign work:

- ✓ U.S. dealers: Submit the request through Audi Warranty Online under the Campaigns/Update option.
- ✓ Canada dealers: Upload the repair order [signed by customer] to Audi WIN/Operations/Campaign Closure.

Service Number	69ET		
Damage Code	0099		
Parts Vendor Code	002		
Claim Type	Sold vehicle: 7 10 Unsold vehicle: 7 90		
Causal Indicator	Mark AIRBAG* as causal part		
Vehicle Wash/Loaner	Do not claim wash/loaner under this action		
Criteria I.D.	4N		
	LABOR		
	Labor Op	Time Units	Description
	6959 55 99	80	Replace passenger airbag
	2706 89 50	10	Connect battery charger
	0151 00 00	Time stated on diagnostic protocol	GFF Operations
	PARTS		
	Quantity	Part Number	Description
	1.00	4N0880204H	AIRBAG*
	4.00	N 91093502	BOLT

Customer Letter Example (USA)

<MONTH YEAR>

<CUSTOMER NAME>

<CUSTOMER ADDRESS>

<CUSTOMER CITY STATE ZIPCODE>

This notice applies to your vehicle: <MODEL YEAR> <BRAND> <CARLINE>, <VIN>

NHTSA: 23V084

Subject: Compliance Recall 69ET - Passenger Frontal Airbag

Dear Audi Owner,

This notice is sent to you in accordance with the National Traffic and Motor Vehicle Safety Act. Audi has decided that certain 2022-2023 model year Audi vehicles fail to conform to Federal Motor Vehicle Safety Standard No. 208, "Occupant Crash Protection". Our records show that you are the owner of a vehicle affected by this action.

What is the issue?

The occupant protection flap of the airbag within the passenger airbag module may not have been folded as specified. Because of this, the vehicles included in this recall may not fully comply with the requirements of an out of position airbag test according to Federal Motor Vehicle Safety Standard No. 208, "Occupant Crash Protection".

The airbag in the affected vehicles is fully functional. However, if a child or small person was seated and unbelted on the front passenger seat and very close to the instrument panel, in a crash the force caused by the inflating airbag on the occupant could be higher than permitted, increasing the risk of injury.

What will we do?

To correct this noncompliance, your authorized Audi dealer will replace the passenger frontal airbag module. This work will take about three hours to complete and will be performed for you free of charge. Please keep in mind that your dealer may need additional time for the preparation of the repair, as well as to accommodate their daily workshop schedule.

What should you do?

Please contact your authorized Audi dealer without delay to schedule this recall repair. For your convenience, you can also visit www.audiusa.com and click on the "Find a Dealer" link to locate a dealer near you and schedule this service.

Lease vehicles and address changes

If you are the lessor and registered owner of the vehicle identified in this action, the law requires you to forward this letter immediately via first-class mail to the lessee within ten (10) days of receipt. If you have changed your address or sold the vehicle, please fill out the enclosed prepaid Owner Reply card and mail it to us so we can update our records.

Can we assist you further?

If your authorized Audi dealer fails or is unable to complete this work free of charge within a reasonable time, please contact Audi Customer Experience at 1-800-253-2834 or via our "Contact Us" page at www.audiusa.com.

Checking your vehicle for open Recalls and Service Campaigns

To check your vehicle's eligibility for repair under this or any other recall/service campaign, please visit the **Recall/Service Campaign Lookup** tool at www.audiusa.com and enter your Vehicle Identification Number (VIN).

If you still cannot obtain satisfaction, you may file a complaint with: The Administrator, National Highway Traffic Safety Administration, 1200 New Jersey Avenue, SE., Washington, DC 20590; or call the toll-free Vehicle Safety Hotline at 1-888-327-4236 (TTY: 1-800-424-9153); or go to <http://www.safercar.gov>.

We apologize for any inconvenience this matter may cause; however we are taking this action to help ensure your safety and continued satisfaction with your vehicle.

Sincerely,

Audi Customer Protection

Customer Letter Example (Canada)

<MONTH YEAR>

<CUSTOMER NAME>

<CUSTOMER ADDRESS>

<CUSTOMER CITY STATE ZIPCODE>

This notice applies to your vehicle: <MODEL YEAR> <BRAND> <CARLINE>, <VIN>

Transport Canada Recall: 2023-069

Subject: Compliance Recall 69ET - Passenger Frontal Airbag

Dear Audi Owner,

This notice is sent to you in accordance with the requirements of the *Motor Vehicle Safety Act*. This is to inform you that your vehicle may be non-compliant with the requirements of the *Motor Vehicle Safety Regulations* and that the non-compliance could affect the safety of a person. Our records show that you are the owner of a vehicle affected by this action.

What is the issue?

The occupant protection flap of the airbag within the passenger airbag module may not have been folded as specified. Because of this, the vehicles included in this recall may not fully comply with the requirements of an out of position airbag test according to Canada Motor Vehicle Safety Standard No. 208, "Occupant Crash Protection".

The airbag in the affected vehicles is fully functional. However, if a child or small person was seated and unbelted on the front passenger seat and very close to the instrument panel, in a crash the force caused by the inflating airbag on the occupant could be higher than permitted, increasing the risk of injury.

What will we do?

To correct this noncompliance, your authorized Audi dealer will replace the passenger frontal airbag module. This work will take about three hours to complete and will be performed for you free of charge. Please keep in mind that your dealer may need additional time for the preparation of the repair, as well as to accommodate their daily workshop schedule.

What should you do?

Please contact your authorized Audi dealer without delay to schedule this recall repair.

Lease vehicles and address changes

If you are the lessor and registered owner of the vehicle identified in this letter, you shall forward this letter (and any subsequent notice, if applicable) to the lessee within ten (10) days of receipt. If you have changed your address or sold the vehicle identified in this letter, please fill out the enclosed prepaid Owner Reply Card and mail it to us so we can update our records.

Can we assist you further?

If your authorized Audi dealer fails or is unable to complete this work free of charge within a reasonable time, please contact Audi Customer Relations Monday through Friday from 8AM to 8PM EST at 1-800-822-2834 or via our "Contact Audi Canada" page at www.audi.ca.

We apologize for any inconvenience this matter may cause; however we are taking this action to help ensure your safety and continued satisfaction with your vehicle.

Sincerely,

Audi Customer Protection

Repair Overview

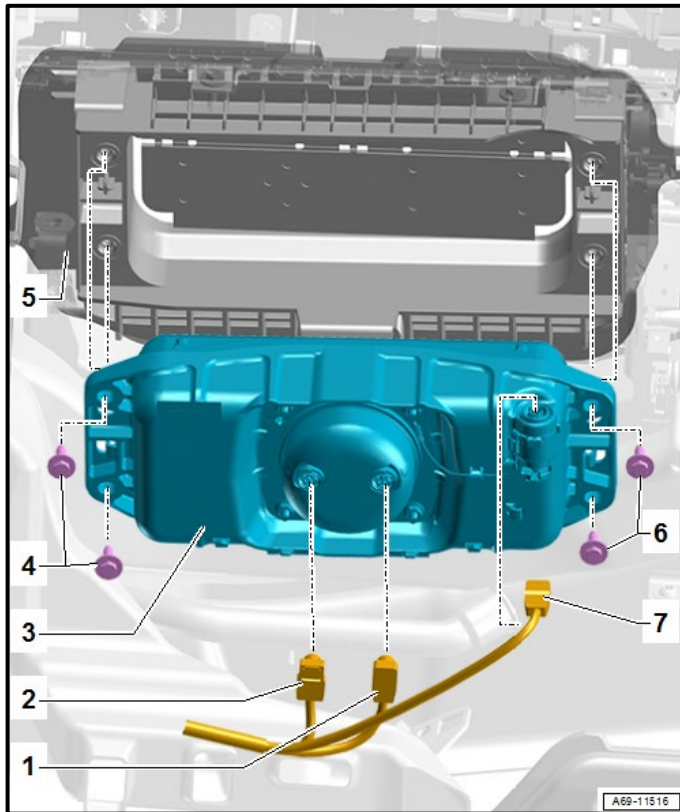



- Replace passenger frontal airbag.

NOTE

- These repair instructions may differ from the labor operations and labor times listed in ELSA.
- Damages resulting from improper repair or failure to follow these work instructions are the dealer's responsibility and are not eligible for reimbursement under this action.
- This procedure must be read in its entirety prior to performing the repair.
- Due to variations in vehicle equipment and options, the steps/illustrations in this work procedure may not identically match all affected vehicles.
- Diagnosis and repair of pre-existing conditions in the vehicle are not covered under this action.
- When working during extreme temperatures, it is recommended that the vehicle be allowed to acclimate inside the shop to avoid temperature-related component damage/breakage.

Required Tools

	<p>Pry lever -80-200- (or equivalent)</p> 
	<p>Trim Removal Wedge -3409- (or equivalent)</p> <p>Wedge Set -T10383- (or equivalent)</p>

Repair Instruction

Section A - Check for Previous Repair

Applicable criteria ID(s)	Campaign/Action Status
01 ← 2	Open ← 1

EXAMPLE

Campaign/Action	Start	Designation
← 3	2015-11-10	W-SERV_ACT -
	2018-12-13	RECALL -
	2017-05-16	A-RECALL -

EXAMPLE

- Enter the VIN in Elsa and proceed to the “Campaign/Action” screen.

TIP

On the date of repair, print this screen and keep a copy with the repair order.

- Confirm the Campaign/Action is open <arrow 1>. If the status is closed, no further work is required.
- Note the Applicable Criteria ID <arrow 2> for use in determining the correct work to be done and corresponding parts associated.

CRITICAL REPAIR STEP

 **STOP!** 

If multiple software update Campaign/Actions are open, they must be performed in order of the Start date <arrow 3>. The oldest should be performed first.

- **All Safety Recalls must be completed prior to completing this campaign.**
- **Proceed to Section B.**

Section B – Repair Procedure

⚠ WARNING

Risk of injury. Refer to “Warning and Safety Precautions”, found in **Appendix A** at the end of this document.

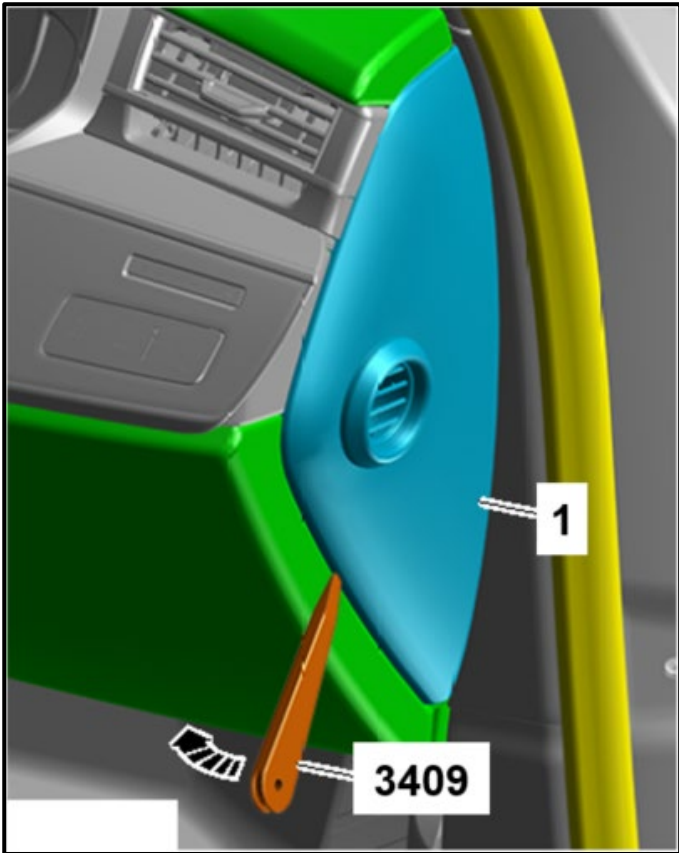

Remove front driver and passenger side instrument panel side covers:

- Pry off the instrument panel side cover <1> using the Trim Removal Wedge -3409- <arrow>.
- Release the remaining retainers, pull the instrument panel cover from the A-pillar gap cover and remove it.

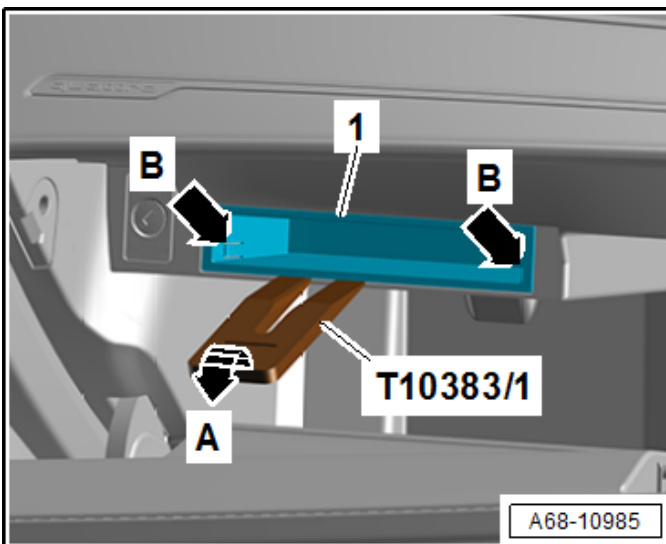

Remove storage compartment (if equipped):

- Using the Wedge -T10383/1- <arrow A>, release the catches <B arrows> at the side carefully one after the other using a small flat-head screwdriver.

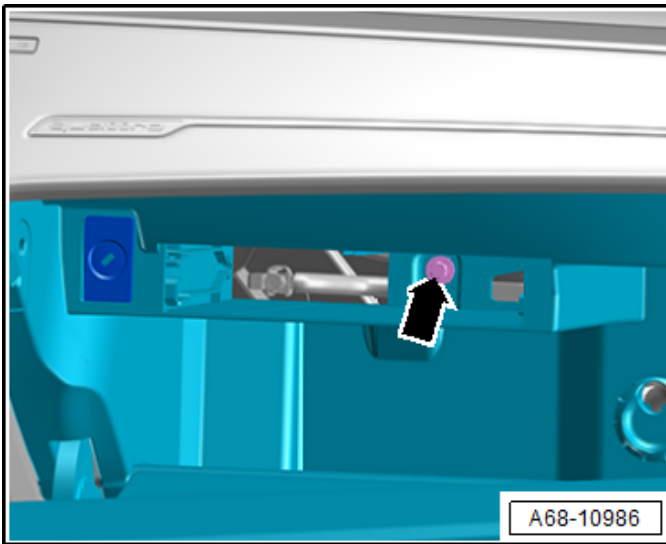

Remove glove compartment:

- Remove the bolt <arrow>.

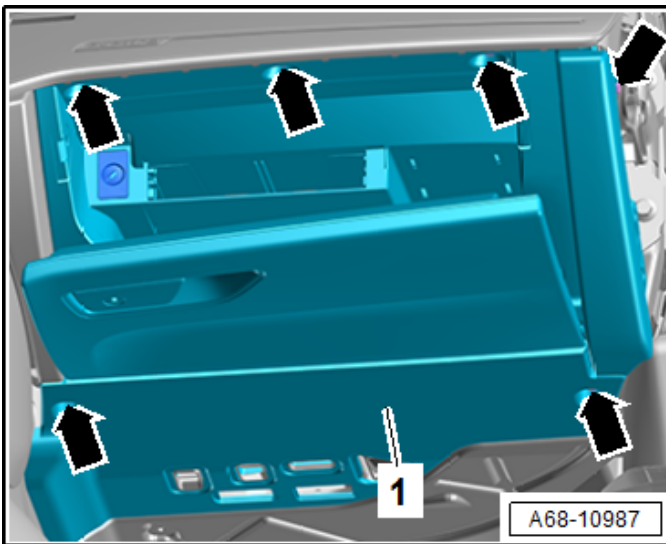

- Remove the bolts <arrows>.
- Slightly remove the glove compartment <1> carefully.

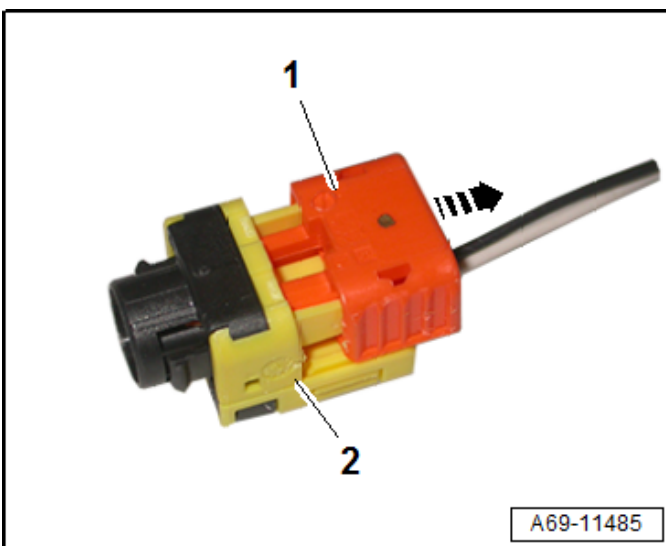

⚠ CAUTION

Pyrotechnical components can deploy unintentionally.

Risk of injury.

Discharge the static electricity: quickly touch the door striker.

- Remove the connector lock <1> <arrow> and remove the connector <2>.

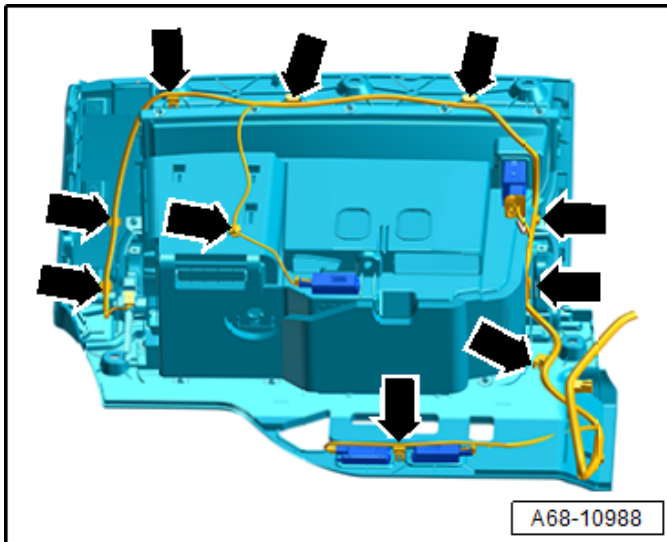

- Disconnect the connectors, unclip the connectors <arrows> using the Pry Lever -80-200- and free it up.
- Remove the glove compartment.

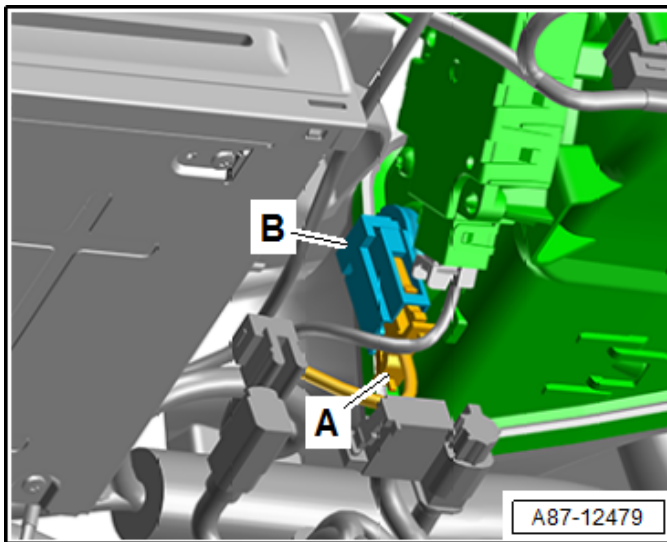

Remove temperature sensor (if necessary):

- Rotate the vent temperature sensor counter-clockwise and remove from the mount.

TIP

Removal of this sensor may be necessary to access a bolt for the Information Electronics Control Module 1 -J794-

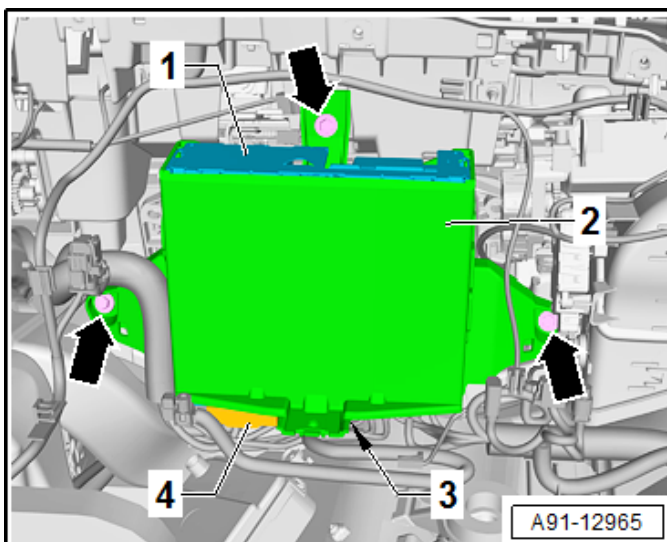

Unbolt the mount for the Information Electronics Control Module 1 -J794-:

- Remove the bolts <arrows> on the bracket <2>.
- Pivot the bracket <2> downward and pull it out of the rear ball socket (refer to item <3>).
- Allow the -J794- to hang by the wiring harness.

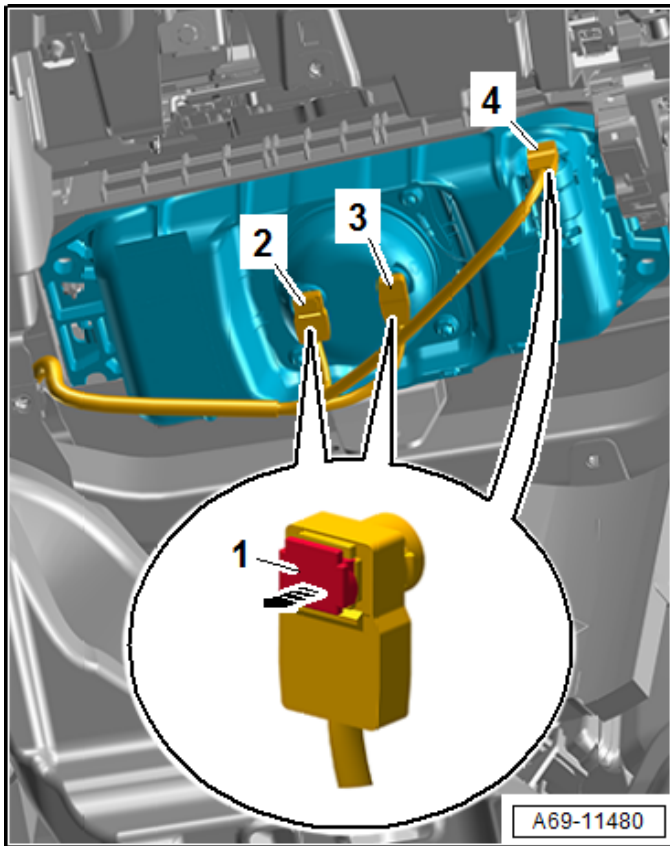

Replace the front passenger airbag:

⚠ CAUTION

Pyrotechnical components can deploy unintentionally.

Risk of injury.

Discharge the static electricity: quickly touch the door striker.

- Release the connector lock <1> with a small flat-head screwdriver <arrow>.
- Disconnect the connectors <2>, <3> and <4> from the Front Passenger Airbag Release Valve Igniter -N491- and Front Passenger Airbag Igniter 1 Front Passenger Airbag Igniter 1 -N131- and the Front Passenger Airbag Igniter 2 Front Passenger Airbag Igniter 2 -N132-.

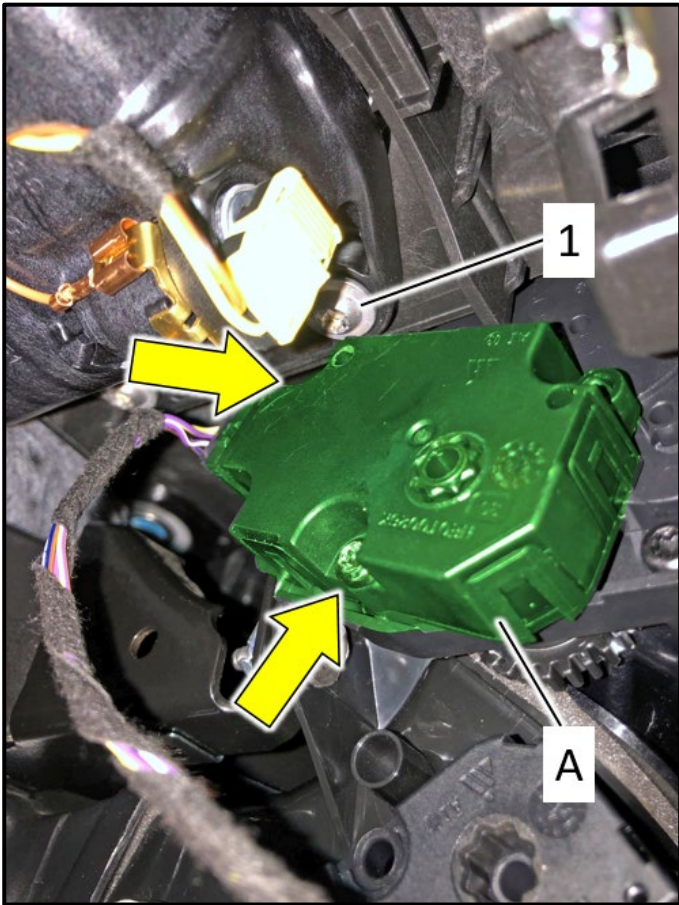

Remove right air vent actuator motor -V209-:

- To access airbag bolt <1>, remove bolts <arrows> and remove actuator motor <A>.
- To avoid having to perform basic settings, leave the actuator motor connector connected.
- Do not turn the actuator motor or rotate the shaft.

TIP

A tool with a maximum dimension <A> of 17 mm should be used.

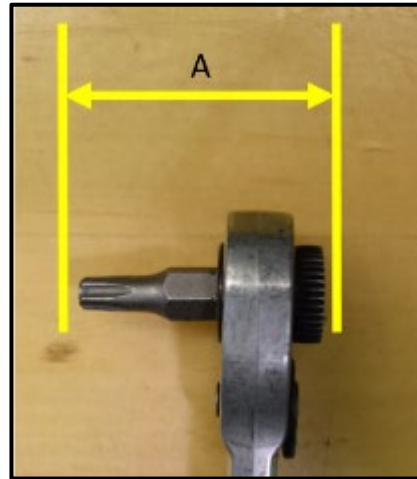

⚠ CRITICAL REPAIR STEP



Remove the bolts using hand tools only.
DO NOT use power tools to remove the bolts.
Use extreme care when removing the bolts.
DO NOT use excessive force/torque when removing the bolts.
DO NOT heat the bolts to loosen the thread lock.
Clean the threads of the nut inserts using a thread tap before installing the new bolts.

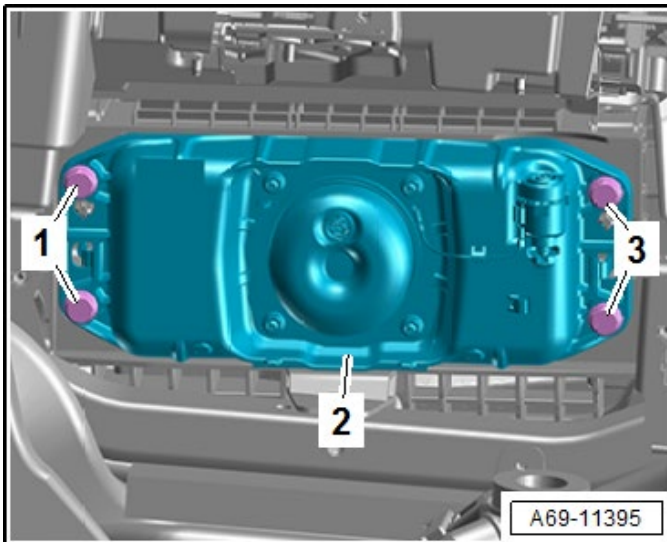

⚠ WARNING

Secure the airbag unit from falling.

Part Number	Part Description
4N0-880-204-H	Airbag
N -910-935-02	Bolt (x4)

- Remove the bolts <1> and <3>.
- Remove the airbag <2> downward.

⚠ WARNING

Risk of airbag deployment.
There is a risk of injury.
Store the airbag with the cushion facing upward.

- Install the new airbag in the reverse order of removal.
- Torque new bolts <1> and <3> to 8 Nm.
- Connect the connector <1> to the airbag igniter <arrow A>.
- Press in the connector lock <2> <arrow B>. While doing this, the connector is pushed into the airbag igniter all the way and locks into place.
- Make sure the wires are not pinched.
- If the instrument cluster indicates a fault in the airbag system after assembly, then the DTC memory must be checked, erased, and then checked again using the diagnostic tester.

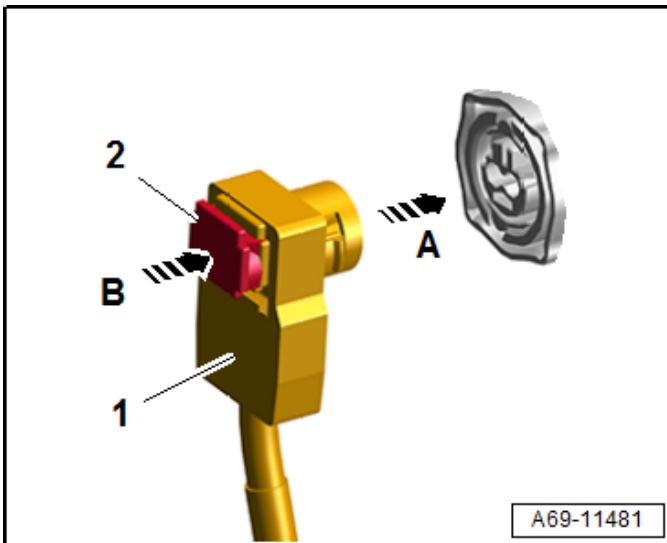

Reassemble vehicle in the reverse order of removal and note the following:

- Reassembly is the reverse order of removal.
- Reference the repair manual if needed.
- Torque HVAC actuator bolts to 1 Nm.
- Torque glove compartment bolts to 3 Nm.

Proceed to Section C

Section C – Campaign Completion Stamp

I certify that this campaign
has been performed in strict
accordance with the applicable
Audi repair procedure.

SAGA Code: _____
Technician: _____
Date: _____

Item#: AUD4927ENG

-OR-

Je certifie que cette
campagne de rappel a été
exécutée suivant les strictes
directives de réparation
d'Audi

Code de SAGA: _____
Technicien: _____
Date: _____

Item # AUD4927FRE

- Once the campaign has been completed, the technician should stamp the repair order.
- Stamps are available for ordering through the Compliance Label Ordering Portal.
- **Proceed to Section D**

Section D - Parts Return/Disposal

Properly store (retain), destroy or dispose of removed parts in accordance with all state/province and local requirements, unless otherwise indicated and/or requested through the Warranty Parts Portal (WPP) for U.S. and the Part Destruction and Core Disposition Report for Canada.

Appendix A – Warning and Safety Precautions

WARNING

General Safety Precautions when Working with Pyrotechnic Components:

- Pyrotechnic components always contain propellant that generates a gas during combustion. In some components, there is also a supply of pressurized gas to ensure this gas is generated
- This pressurized gas is stored under high pressure in a compressed gas container. Pyrotechnic components are triggered by electrical/mechanical igniters.
- Only trained personnel should perform testing, assembly and servicing work. Airbags do not have a replacement interval.
- Never check with test lamps, voltmeter or ohmmeters.
- Only check pyrotechnic components when they are installed in the vehicle using vehicle diagnosis, testing and information systems approved by the manufacturer.
- When working on pyrotechnic components and the airbag control module, disconnect the battery ground strap while the ignition is switched on. Then cover the negative terminal.
- Wait 10 seconds after disconnecting the battery.
- The ignition must be SWITCHED ON when connecting the battery. There should not be anyone inside the vehicle when doing this.
- Exception: vehicles with batteries in the passenger compartment. In this case, stay outside the range of the airbags and seat belts.
- Wash your hands after touching ignited pyrotechnic components from the restraint system.
- Do not open or repair pyrotechnic components. Use only new components to reduce the risk of injury.
- Do not install pyrotechnic components that have fallen onto a hard surface or show signs of damage.
- Discharge static electricity before handling pyrotechnic components, for example before disconnecting the electrical connector. This can be done by touching grounded metal objects such as the door striker pin.
- Install pyrotechnic components immediately after removing them from their transport packaging. If you must stop working, store the pyrotechnic component in its original transport packaging.
- Do not leave pyrotechnic components lying in the open unattended.
- Do not treat pyrotechnic components with grease, cleaning solutions or similar products.
- Do not expose pyrotechnic components to temperatures above 100 °C, even for brief periods of time.
- People in the immediate vicinity of the workplace must be protected from possible noise and projectiles.
- Pyrotechnic components can trigger unintentionally.
- In the event of deployment:
 - Single-stage inflators: allow airbag to cool down completely. Wait at least 10 minutes before handling.
 - Two-stage inflators: wait for second airbag ignition. Allow airbag to cool down completely. Wait at least 10 minutes before handling.