

- ATTENTION:**
- GENERAL MANAGER
  - PARTS MANAGER
  - CLAIMS PERSONNEL
  - SERVICE MANAGER

IMPORTANT - All Service Personnel Should Read and Initial in the boxes provided, right.

© 2023 Subaru of America, Inc. All rights reserved.



QUALITY DRIVEN® SERVICE

**PRODUCT CAMPAIGN BULLETIN**

**APPLICABILITY:** 2019-2022 Crosstrek Hybrid

**NUMBER:** WRD-23R

**SUBJECT:** 12V Inverter Connector Corrosion

**DATE:** 04/24/23

**REVISED:** 05/02/23

**NHTSA ID:** 23V-080

Subaru of America, Inc. (Subaru) is initiating a new safety recall for certain 2019-2022 model year Crosstrek Hybrid vehicles.

**Description of the Defect and Safety Risk**

The harness terminal that supplies low-voltage power from the converter to the 12V battery may corrode, and over time, could cause the terminal to break. If the terminal breaks, the 12V battery may not recharge as a result of this condition.

If the harness terminal breaks and the 12V battery is unable to recharge, the vehicle may experience a loss of motive power, increasing the risk of a crash.

**Remedy**

For all affected vehicles, Subaru will replace the converter terminal mounting bracket with a new bracket with improved isolation. If there is no corrosion found on the terminals of the 12V output harness, a protective rubber cap will be installed on the terminals. If corrosion is found on the terminals, Subaru dealers will replace the 12V output harness, including the terminals, with a new one.

**Affected Vehicles**

A total of 8,413 U.S. Crosstrek Hybrid vehicles will be affected by this recall, as listed below:

Model Year	Carline	Production Date Range
2019-2022	Crosstrek Hybrid	November 16, 2018 – April 8, 2022

Not all vehicles in the production range listed above are affected by this recall. Coverage must be confirmed by using the Vehicle Coverage Inquiry function on [subarunet.com](http://subarunet.com) prior to repair.

**CAUTION: VEHICLE SERVICING PERFORMED BY UNTRAINED PERSONS COULD RESULT IN SERIOUS INJURY TO THOSE PERSONS OR TO OTHERS.**

Subaru Service Bulletins are intended for use by professional technicians ONLY. They are written to inform those technicians of conditions that may occur in some vehicles, or to provide information that could assist in the proper servicing of the vehicle. Properly trained technicians have the equipment, tools, safety instructions, and know-how to do the job correctly and safely. If a condition is described, DO NOT assume that this Service Bulletin applies to your vehicle, or that your vehicle will have that condition.

**Subaru of America, Inc. is ISO 14001 Compliant**

ISO 14001 is the international standard for excellence in Environmental Management Systems. Please recycle or dispose of automotive products in a manner that is friendly to our environment and in accordance with all local, state and federal laws and regulations.

*Continued...*

## *Retailer Responsibility*

***Please be advised that it is a violation of Federal law for a dealer to deliver a new motor vehicle covered by a recall under a sale or lease until the defect is remedied. Therefore, any Authorized Subaru Retailer failing to perform the applicable service procedures to correct all affected vehicles in their inventory prior to the vehicle being placed in service may be subject to civil penalties of up to \$26,315 per violation (i.e., for each vehicle), as provided in 49 CFR §578.6 and will also be in breach of the Subaru Dealer Agreement.***

Any vehicles listed in any recall/campaign that are in retailer stock must be:

- Immediately identified
- Tagged or otherwise marked to prevent their delivery or use prior to repair
- Repaired in accordance with the repair procedures outlined in the Product Campaign Bulletin

Retailers are to promptly perform the applicable service procedures, to correct all affected vehicles in their inventory (used, demo & SSLP). Whenever a vehicle subject to this recall is taken into retailer inventory necessary steps should be taken to ensure the recall correction has been made before selling or releasing the vehicle.

## *Owner Notification*

Subaru notified affected owners of this recall with an interim notification letter on April 14, 2023.

**Owners will be renotified by first class mail on May 12, 2023, and will be advised to schedule an appointment for this repair.**

## *Required Technician Training*

Subaru technicians will be required to take and pass the **WRD-23 12-Volt Inverter Connector Corrosion Video and Post Test** before performing the WRD-23 recall service procedure. The video and post test are currently available on STAR-U.



Technicians must also complete the following required WBT courses in STAR-U, before performing the WRD-23 recall service procedure. These WBT courses are currently available, and technicians are encouraged to be completed prior to enrolling in the WRD-23 Volt Inverter Connector Corrosion Video and Post Test.

- 2019 Crosstrek Hybrid Introduction (13L301101W)
- 2019 Crosstrek Hybrid Safety (13L301103W)
- 2019 Crosstrek Hybrid Technical (13L301102W)
- 2023 Subaru Solterra - Systems and Features WBT (80L200103W)
- 2023 Subaru Solterra - High Voltage Systems WBT (80L200104W)
- EV Power Down Video (20L000120W)

***Continued...***



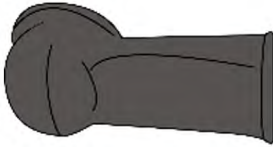

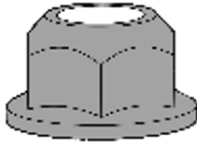
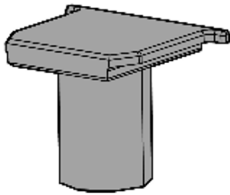
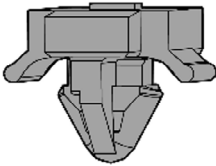
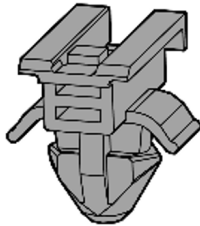
**PART INFORMATION:**

Part Description	Part Number	Qty
BKT AY-INV & CONV KIT	X10099AA080	1

<b>BKT AY-INV &amp; CONV KIT (X10099AA080) Component Breakdown</b>			
Part Description	Qty	Image	Details
BKT AY-INV & CONV	1		Inverter rear bracket with insulated rustproof paint
BOOT TERMINAL	1		Rubber protective boot for 12V terminal of the HV air conditioning wire
BOLT	2		For mounting the inverter rear bracket
FLANGE NUT	1		For mounting the 12V terminal of the HV air conditioning wire
ANCHOR PROTR TBD	1		
CLAMP(ETC-CONN)	1		Spare parts when broken during removing and installing the HV air conditioning wire
ANCHOR PROTR 7D	3		

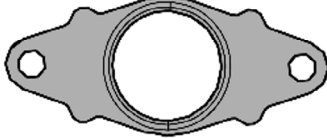
*Continued...*

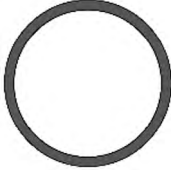
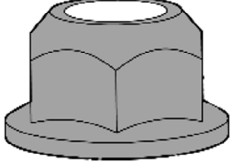
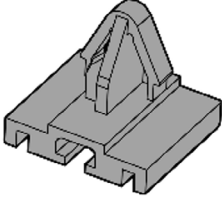
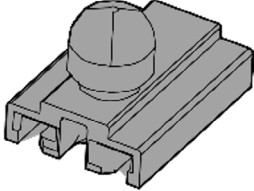
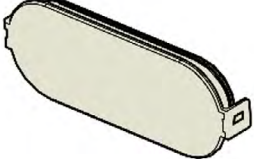



**BKT AY-INV & CONV KIT (X10099AA080) Component Breakdown Continued**

Part Description	Qty	Image	Details
GASKET-EXHAUST	2		Non-reusable parts for removing and installing the exhaust pipe
GSKT-EGR PIPE	1		
GASKET(CR)	1		
GASKET	1		
SELF LOCK NUT M10	2		
ANCHOR PROTR TMC	1		Spare parts when broken during connecting and disconnecting the motor cable
ANCHOR PROTR FFL	1		
COVER-POWER CONN	2		
BOLT FLG 14X163	1		Non-reusable parts for removing and installing the rear member support

*Continued...*

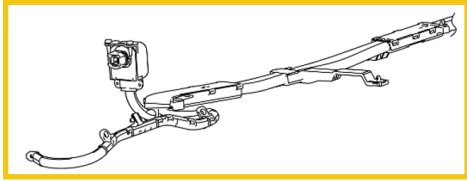
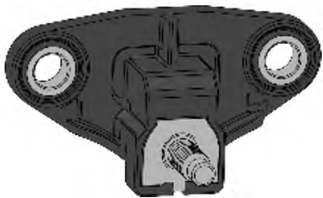
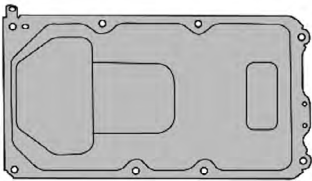
**ADDITIONAL PARTS DEPENDING ON RESULTS OF INSPECTION:**

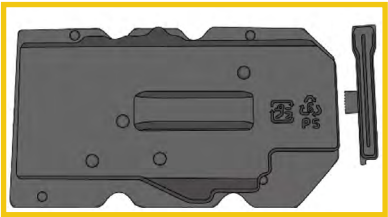
Part Description	Part Number	Qty
WRD-23 HV CORD KIT	SOA635176	1

<b>WRD-23 HV CORD KIT (SOA635176) Component Breakdown</b>			
Part Description	Qty	Image	Details
HV CORD AY PHV (HV air conditioning wire)	1		Requires replacement if corrosion is found
TERMINAL, OUTPUT (12V terminal)	1		Replacement for corroded terminal
COVER, CONVERTER (Inverter lid)	1		Non-reusable parts for removing and installing the 12V terminal
BOLT, FLANGE (Bolts)	11		For mounting the 12V terminal and inverter lid
COVER, HV CONVERTER	1		Used to prevent debris intrusion of the inverter/converter
CAP (Rubber cap)	2		Used to prevent coolant drippage during work procedures

*Continued...*

**PARTS ORDERING:**

Retailers in the following states, where the Crosstrek Hybrid models were originally sold, must order the parts for this recall through PRIME:

**CA, CO, CT, DE, MA, MD, ME, NJ, NY, OR, PA, RI, VT, and WA.**

Part Number	Part Description	PRIME Max Qty
X10099AA080	Bkt Ay-Inv & Conv Kit	3
SOA635176	HV Cord Kit	1

Retailers in states not listed above must contact the PIC line to order parts at (866) 782-2782 option 1.

**REQUIRED TOOLS:**

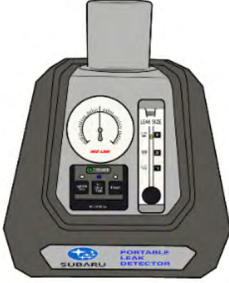

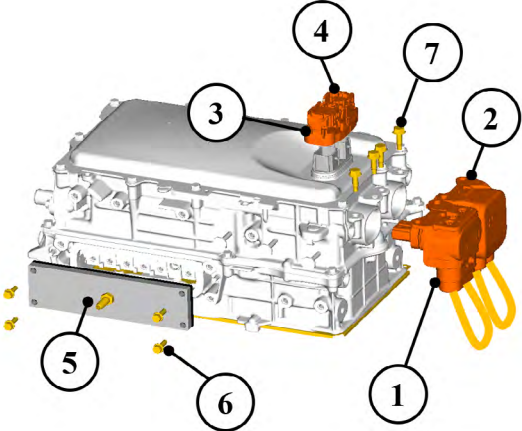

Part Description	Qty	Image
Leak Detector (Essential Tool) For inspecting air leak from the inverter with converter assembly after replacing the 12V terminal	1	

Part Description	Part Number	Qty
WRD-23 LEAK TEST TOOL KIT	SOA635177	1





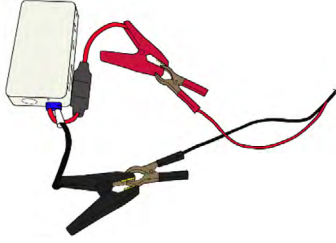

**IMPORTANT:** SOA635177 will be automatically shipped 1 per retailer.

WRD-23 Leak Test Tool Kit (SOA635177)			
Part Description	Part Number	Qty	Image
CONNECTOR HOLDER (No. 1)	81911FL010	1	
CONNECTOR HOLDER (No. 2)	81911FL050	1	
CONNECTOR HOLDER (No. 3)	81911FL040	1	
CONNECTOR HOLDER (No. 4)	81911FL030	1	
REPAIR TOOL (No. 5)	99804AN030	1	
FLANGE BOLT (No. 6)	010406200	4	
FLANGE BOLT (No. 7)	010406120	4	
Details			
For inspecting air leak from the inverter with converter assembly after replacing the 12V terminal			

*Continued...*

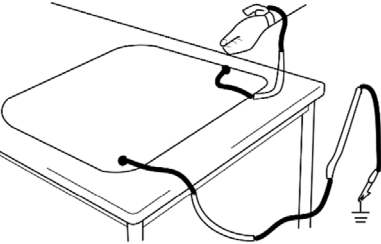
Part Description	Qty	Image	Details
Non-metallic Sealant Scraper	1		For removing sealant. (To prevent any damage to the sealant surface, DO NOT use metallic scraper)
Caulking Gun	1		For applying sealant.
12V External Power Supply	1		For supplying 12V power to the leak detector.
Silicon Hose	1		To be used when performing leak check (Inner Diameter: 7mm/0.3 in)
Spray Nozzle (3M Cavity Wax Plus Applicator Wand Kit or general nozzle)	1		To be used with 3M Cavity Wax Plus spray (3M# 7100088894)

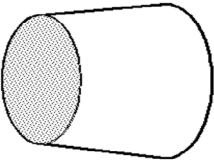

*Continued...*

Part Description	Qty	Image	Details
Insulated Hand Tools	1		For removing and installing bolts for the high voltage components
High Voltage Insulated Gloves (Additional Information Provided Below)	1		To be used when removing and installing the high voltage components
Antistatic Mat	1		For preventing static electricity from electronic parts
Antistatic Strap			For preventing static electricity from electronic parts
Circuit Tester	1		For measuring the high voltage
Coolant Hose Cap	6		For preventing engine coolant dripping from the coolant hose
Hand Riveter	1		For installing the inverter/converter cover
Wooden Blocks	1		To be used to support the inverter/converter cover replacement

*Continued...*



**REQUIRED CHEMICALS FOR 12V TERMINAL REPLACEMENT:**

Product Name	Qty	Remarks	Image
3M Cavity Wax Plus (3M# 7100211448)	Appropriate amount	For rust prevention	
Three Bond 1207F (SOA868V9650) Warranty Number SOA635336	Appropriate amount	Sealant	

**HIGH VOLTAGE INSULATED GLOVE INFORMATION:**

- New gloves and sleeves are marked with the date of manufacture/electrical test and are acceptable for use 12 months from that date.
- If new gloves are first used within 12 months of the manufacture/electrical test date, re-certification must occur 6 months from first use. The first use date should be recorded.
- If the first use date is not known, the gloves/sleeves must be retested 6 months from the electrical test date stamped on the glove/sleeve.
- All gloves must be inspected by the user for damage prior to each use.
- The gloves include a stamped date indicating when the rubber insulating gloves were “originally or last tested electrically.” Rubber insulating gloves must be re-tested electrically by a certified lab 6 months after first use. The lab will re-stamp the gloves with the new “tested” date.

*Continued...*

**SERVICE PROCEDURE FLOW CHART:**

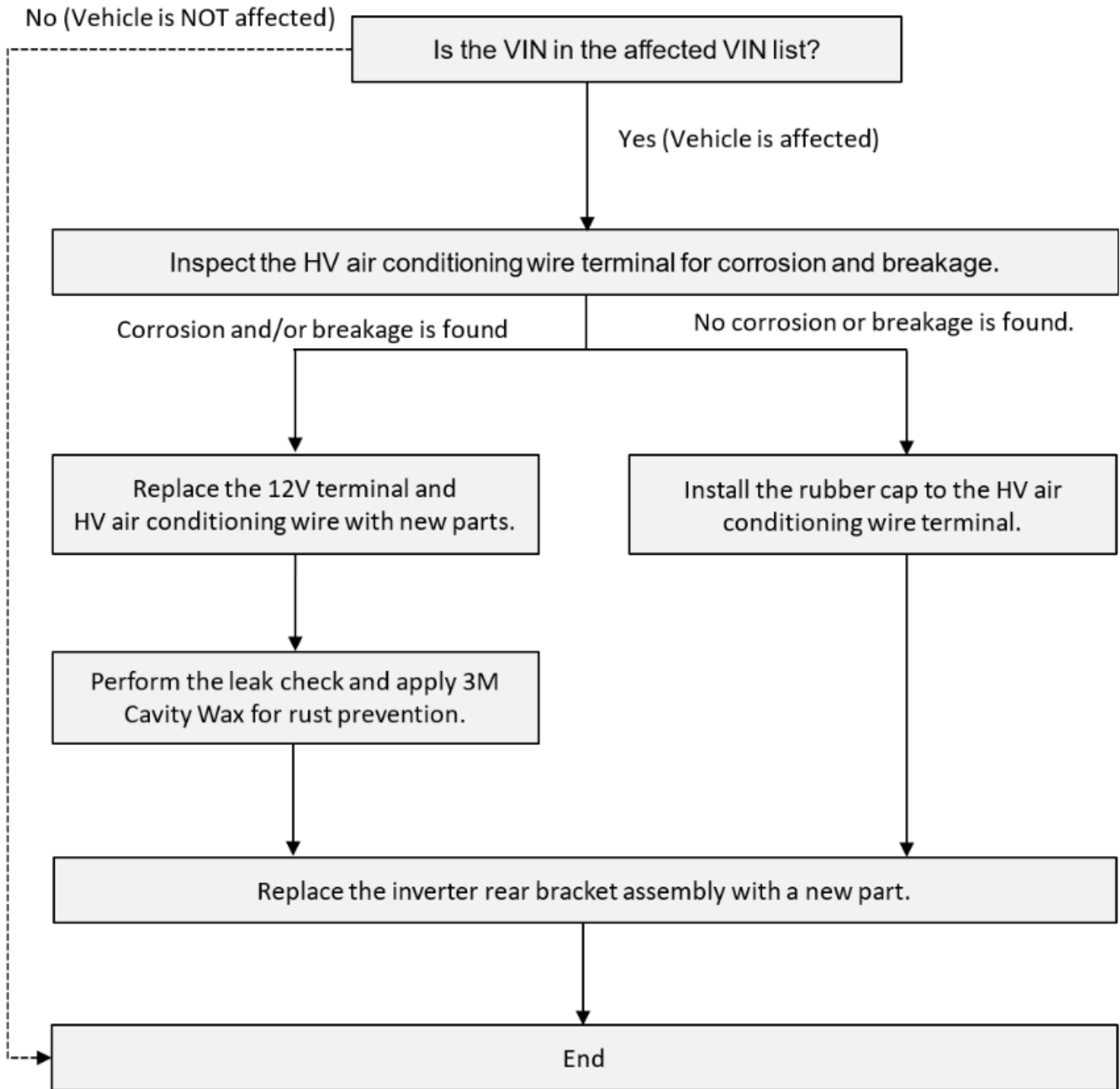

*Continued...*

# COMPONENT DETAILS / CONFIGURATION:

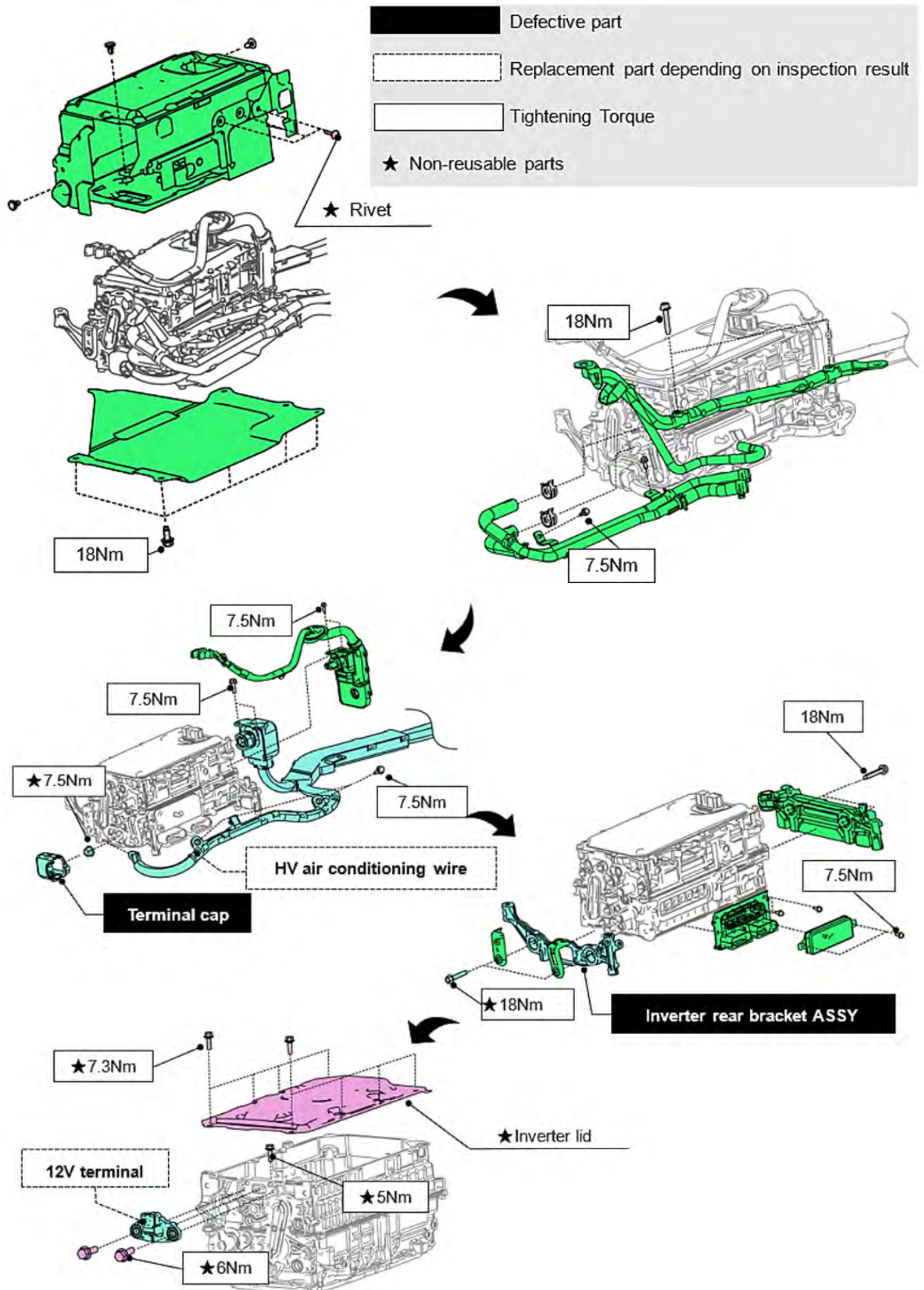

*Continued...*

## INSPECTION PROCEDURE:

**STEP 1:** Refer to the applicable Service Manual and review: General Description > Repair Contents > Action required before & after Battery Disconnect. Open the rear gate Confirm the key is not inside the vehicle. **CAREFULLY** disconnect the negative battery cable from the battery.

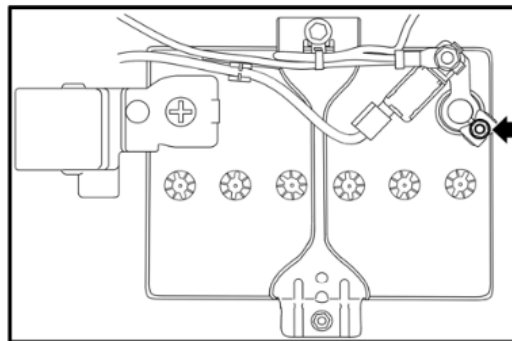

**STEP 2:** Remove the rear floor mat from the cargo area.

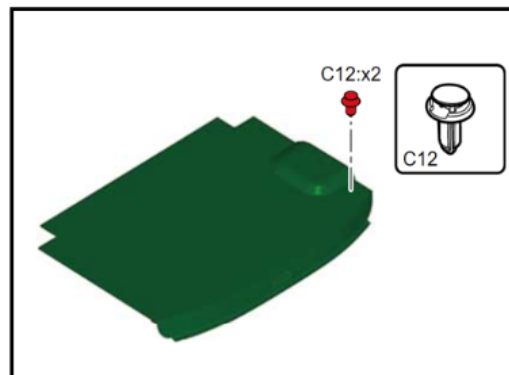

**STEP 3:** Remove the service plug cover.

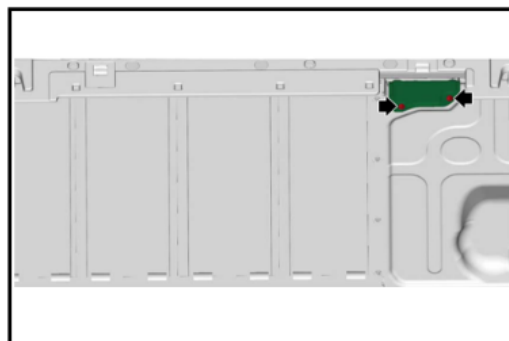

## PRECAUTIONARY INFORMATION:

- **When working on high voltage systems, always wear high voltage insulated gloves.**
- **After the service disconnect plug is removed, the inverter/converter assembly will still contain a high voltage charge. Wait for period of ten minutes or more, prior to proceeding with work procedures to any high voltage components, wiring, terminals and connections.**
- **To prevent any damage to the high voltage systems, DO NOT operate the ignition switch while the service disconnect plug is removed.**
- **After removing the service disconnect plug, protect the plug socket with tape to prevent any intrusion of foreign matter such as water or dust. DO NOT touch the service disconnect plug terminals.**

*Continued...*

**IMPORTANT: Insulated gloves MUST be used for STEPS 3, 4, & 5.**

**STEP 3:** Slide the lever of the service disconnect plug toward the driver side of the vehicle.



**STEP 4:** Raise the lever to the vertical position.



**STEP 5:** Pull the lever in the upward direction and removed the service disconnect plug.



**STEP 6:** Raise the vehicle using the lift manufacturer's specified procedures.

**STEP 7:** Remove the inverter/converter assembly lower cover.

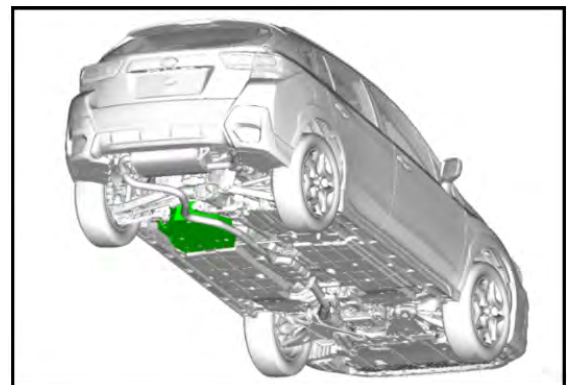

*Continued...*

**STEP 8:** Open the terminal cap cover. Remove the 12v terminal nut. The terminal nut is a one-time use part and must not be reused.

**CAUTION:** Some vehicles may have a protective rubber boot installed in place of the terminal cap. If found, remove and discard the rubber boot.

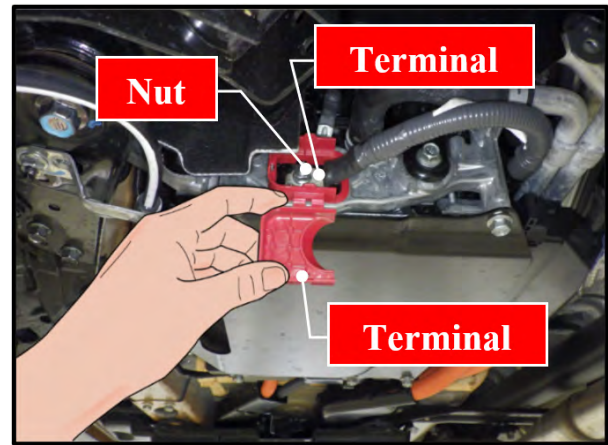

**STEP 9:** Perform a visual inspection of the High Voltage (HV) air conditioning wire terminal for corrosion and/or damage. See the example images below.

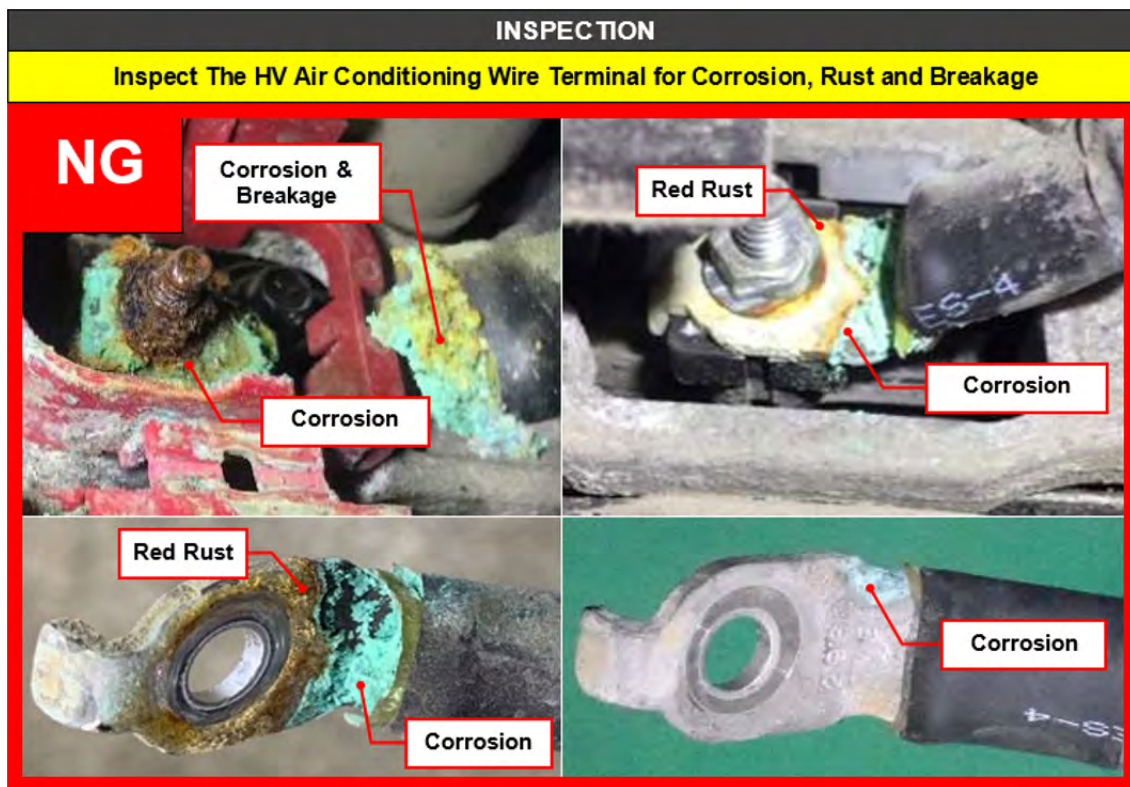
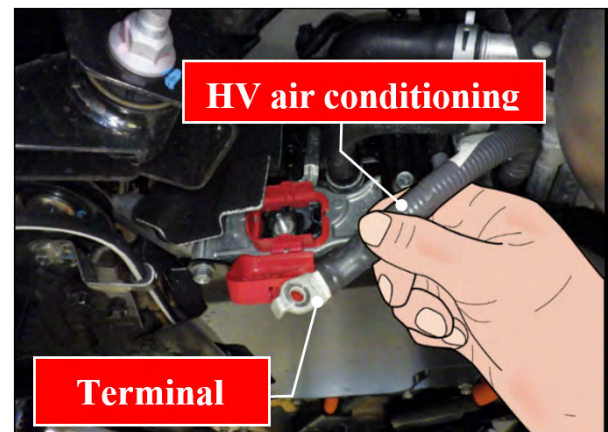

*Continued...*

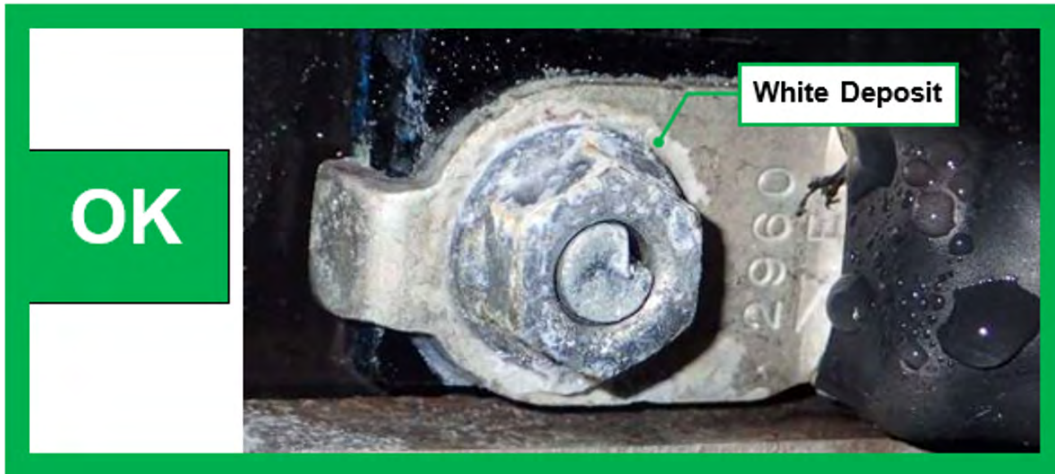

**NOTE:** White Deposits found on the terminal is considered acceptable.

Inspection Result		Next Step
<b>OK</b>	No Corrosion, Red Rust and/or Breakage found	Proceed to Service Procedure A
<b>NG</b>	Corrosion, Breakage, and/or Red Rust was found	Proceed to Service Procedure B

**SERVICE PROCEDURE A:**

**WHEN NO CORROSION, RED RUST, AND/OR BREAKAGE IS FOUND DURING INSPECTION.**

**PRECAUTIONARY INFORMATION:**

- **When working on high voltage systems, always wear high voltage insulated gloves.**
- **During disassembly and reassembly of the inverter/converter assembly, BE CAREFUL not to cause or induce any static electricity.**
- **ALWAYS place the inverter/converter assembly and any other removed electronic components on an antistatic work mat after removal.**
- **Keep any foreign matters such as water and dust from entering the inverter/converter assembly.**
- **Be CAREFUL not to make contact with the electronic components within the inverter/converter assembly.**

*Continued...*

**STEP 1:** Remove the inverter/converter assembly from the body of the vehicle using the work procedures outlined in the applicable Service Manual. Refer to STIS: Body & Electrical/WIRING SYSTEM > HYBRID ELECTRIC VEHICLE > Inverter and Converter Assembly

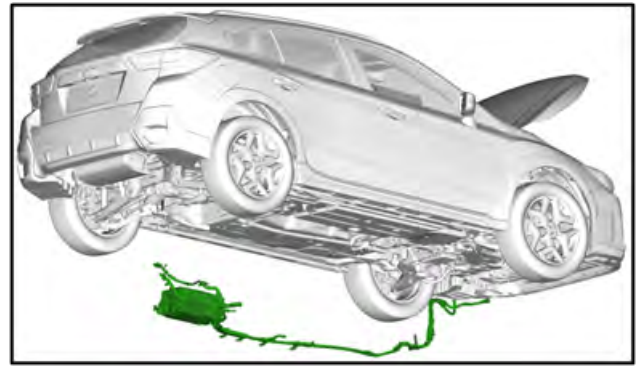

**TIP 1:** ALWAYS perform the required voltage checks as outlined in the Service Manual. A zero-voltage reading at these required points is vital for confirming safe working conditions.

**CAUTION:** ALWAYS wear high voltage insulation gloves when performing the voltage checks.

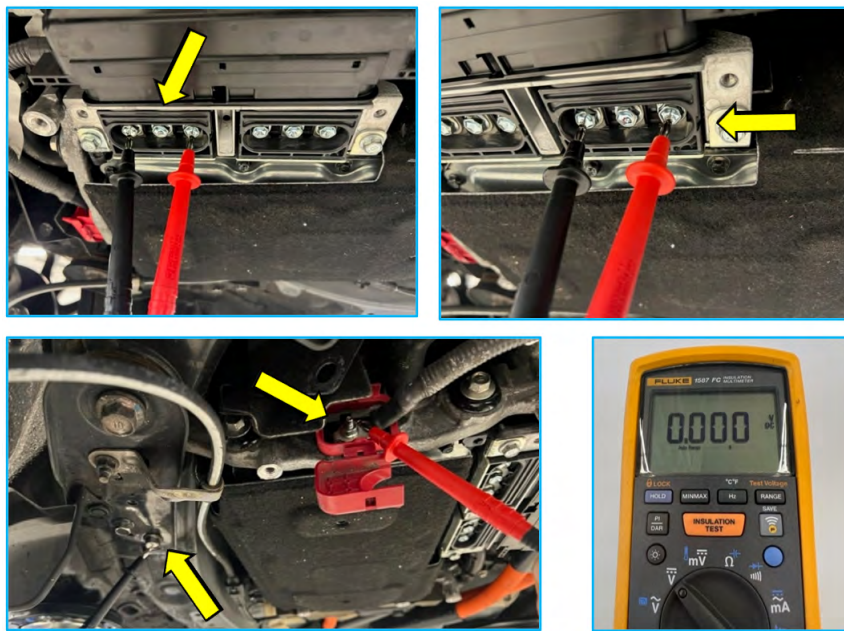

**TIP 2:** Removing the ECM provides additional cable slack when working in the upper and lower engine area during removal of the HV air conditioning cable.

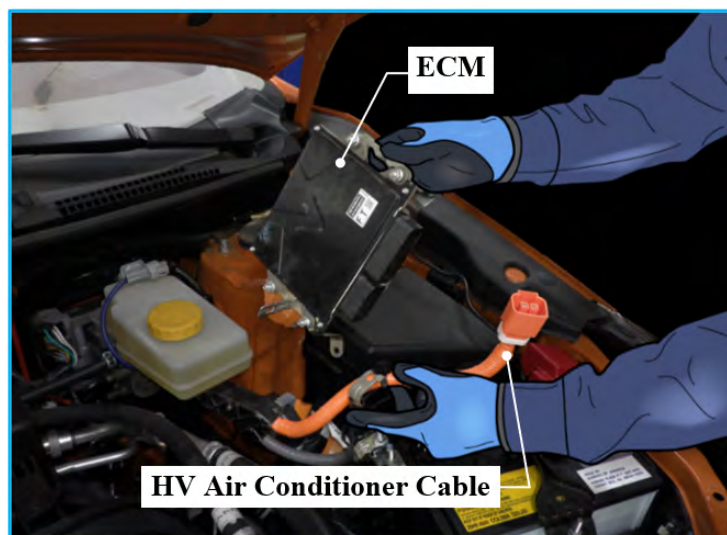

*Continued...*



**STEP 2:** CAREFULLY remove the three retaining clips and the three rivets. The inverter/converter insulation cover can then be removed.

**CAUTION:**

- Release the rivets with a drill for removal. To prevent any damage to the inverter/converter assembly, support the back side of the rivet with a trim tool or pliers.
- The spacers attached to the cover MUST be reused. DO NOT discard the spacers.

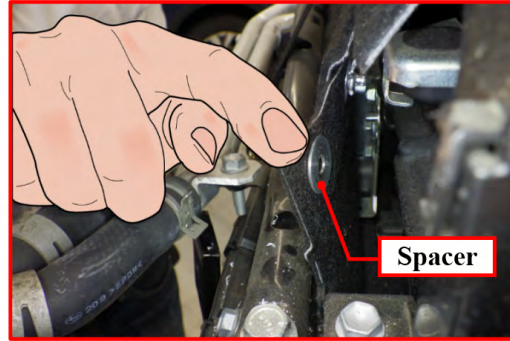
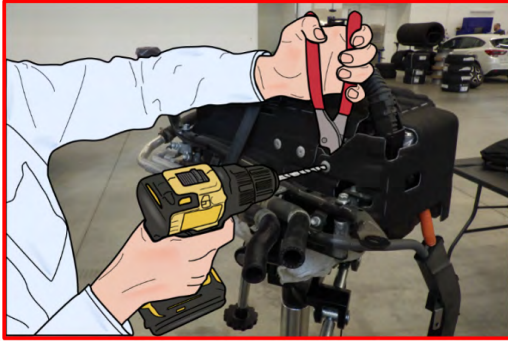

**STEP 3:** Remove the two HV air condition cable mounting bolts. Release the retaining clip and move the HV air conditioning cable to allow room for workspace.

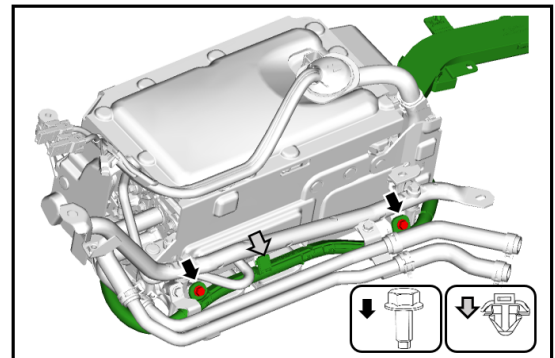

**STEP 4:** Remove and discard the terminal cap or protective rubber boot.

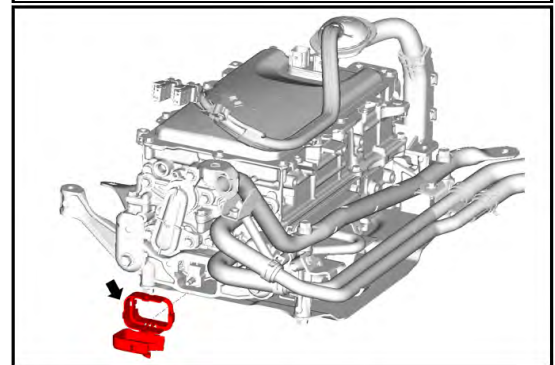

**STEP 5:** Remove the hose clamps from the connections indicated with yellow arrows in the right image. Remove the two water pipe mounting bolts. Install the provided rubber caps onto the aluminum pipes to prevent any coolant drippage while working. The water pipe can then be lowered to allow access to the inverter/converter assembly.

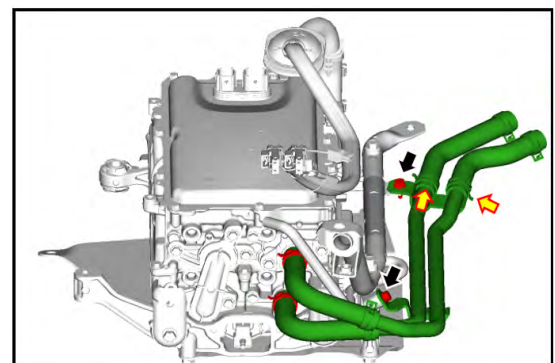

*Continued...*

**NOTE:** The following images show the water pipes removed from the inverter/converter assembly in order to provide more detail for instructional purposes.

**STEP 6:** Remove the five inverter protector mounting bolts. The inverter protector can then be removed.

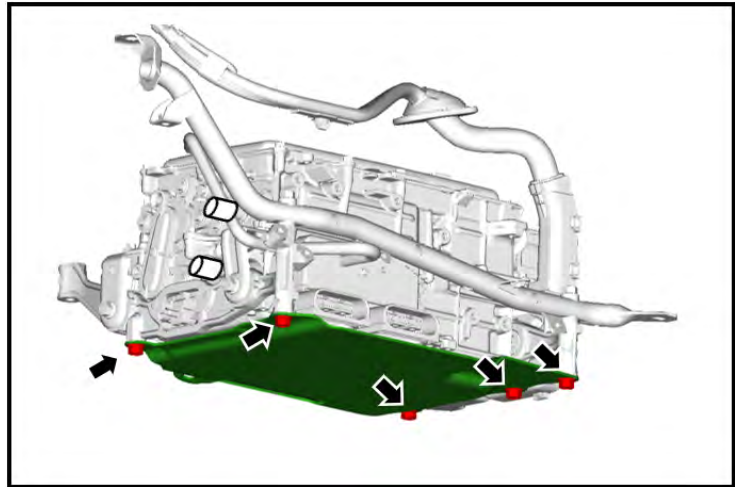

**STEP 7:** Place the inverter/converter assembly on two wooden blocks.

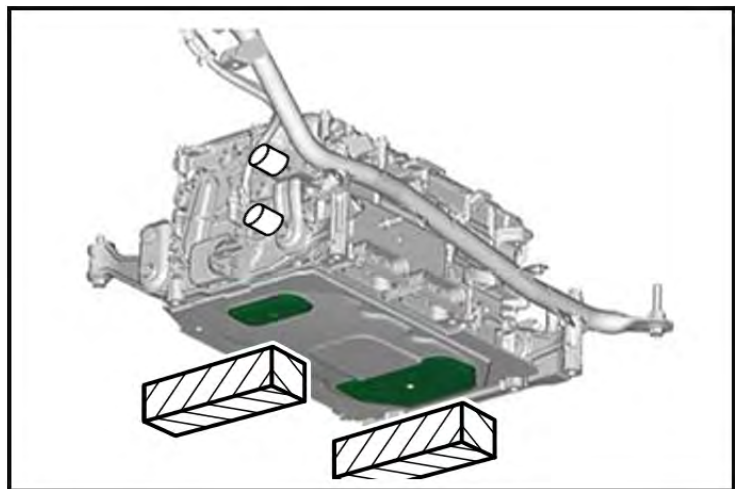

**STEP 8:** Remove the two mounting bolts for the inverter stay. The stay can then be removed.

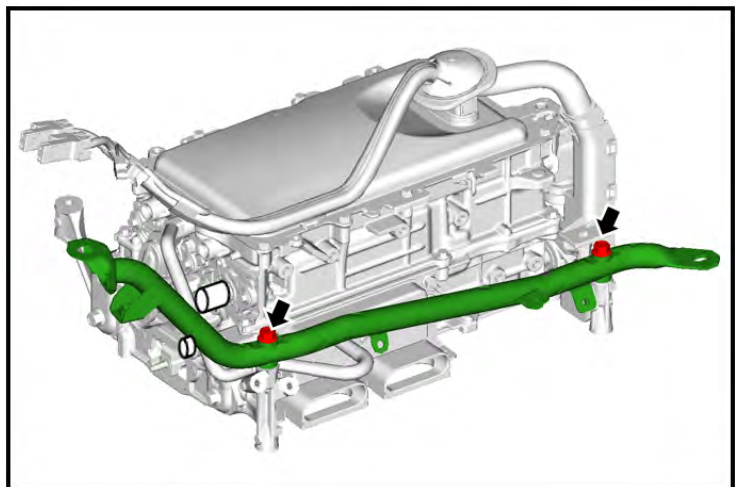

*Continued...*

**STEP 9:** Remove the mounting bolts and stays holding the rear inverter bracket. The rear bracket assembly can then be removed.

**IMPORTANT NOTE:** The mounting bolts are one-time use parts and can be discarded. The stays are NOT to be discarded and MUST be re-used.

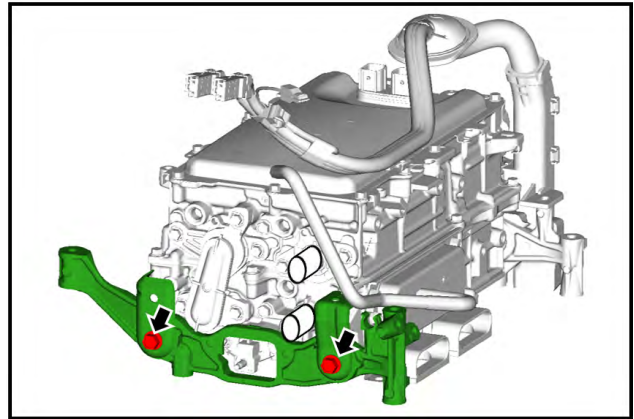

**STEP 10:** Install the NEW black painted rear inverter bracket using the NEW mounting bolts. Torque the mounting bolts to 18Nm (13.3ft-lbs).

**CAUTION: DO NOT drop or hit the new mounting bracket. This can cause the painted surface to be damaged compromising its corrosion protective strength.**

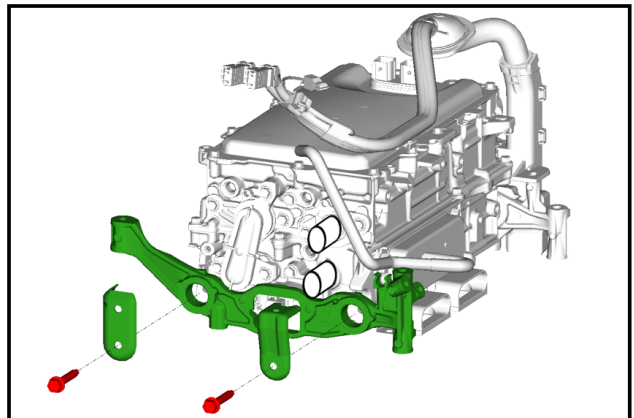

**STEP 11:** Install the inverter stay using the two original mounting bolts. Torque the mounting bolts to 18Nm (13.3ft-lbs).

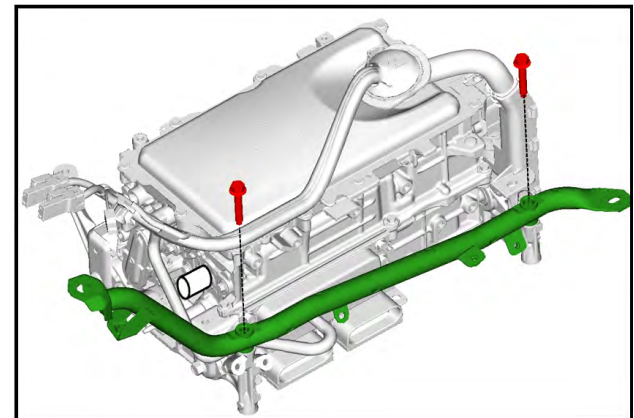

**STEP 12:** Reinstall the inverter protector with the original mounting bolts in the following order.

1. Bolt (a)
2. Bolt (b)
3. Bolts (c)

Torque the mounting bolts in the same order to 18Nm (13.3ft-lbs).

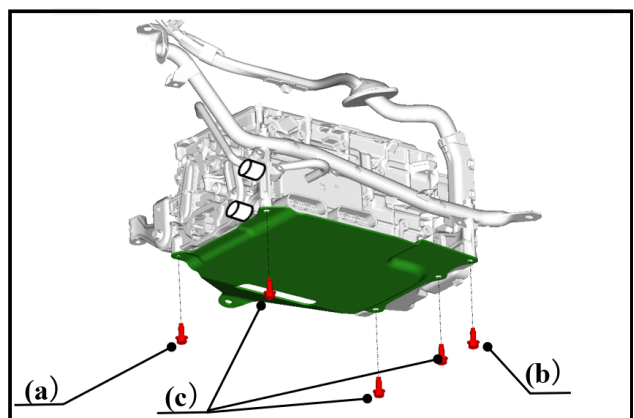

*Continued...*

**STEP 13:** Remove the rubber caps from the water pipe. Reinstall the coolant hoses and clamps. Reattach the water pipe to the inverter/converter assembly using the original mounting bolts. Torque the bolts to 7.5Nm (5.5ft-lbs).

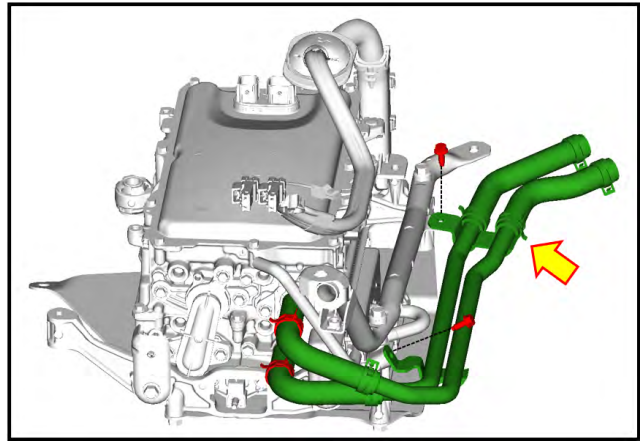

**STEP 14:** Route the HV air conditioning cable through the NEW rubber protective boot.

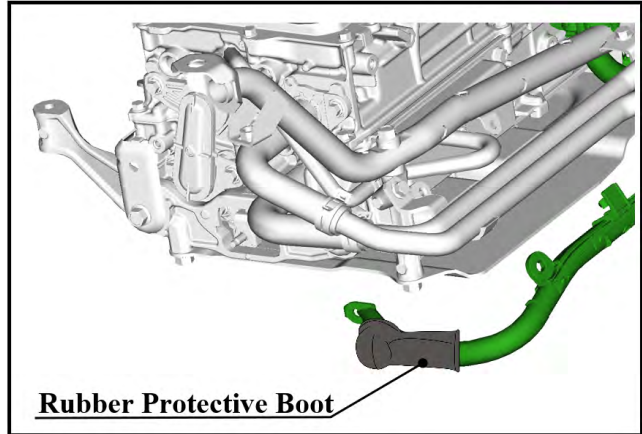

**STEP 15:** Secure the HV air condition cable to the inverter/converter using the original bolts and the new retaining clip. Torque the bolts to 7.5Nm (5.5ft-lbs).

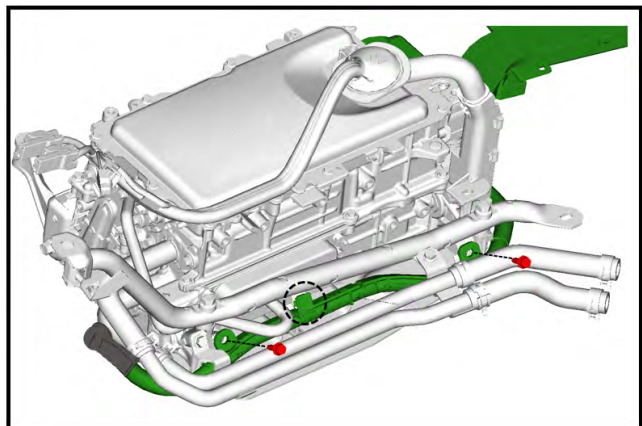

**STEP 16:** Connect the HV air conditioning cable to the 12v terminal. Torque the NEW nut to 7.5Nm (5.5ft-lbs).

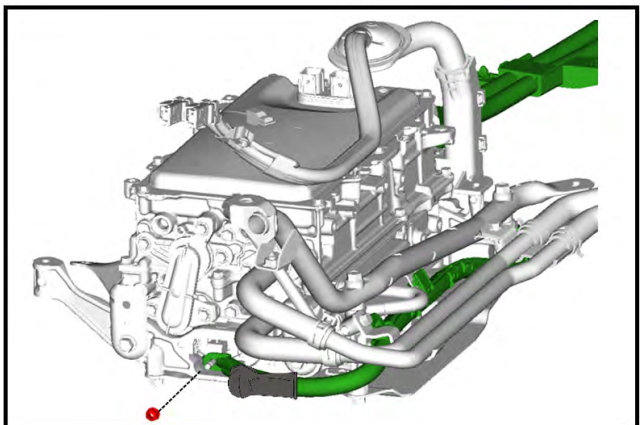

*Continued...*

**STEP 17:** Attach the new rubber cap to the 12v terminal.

**CAUTION:** Confirm the 12v terminal is completely covered by the rubber cap. The terminal **MUST** not be exposed.

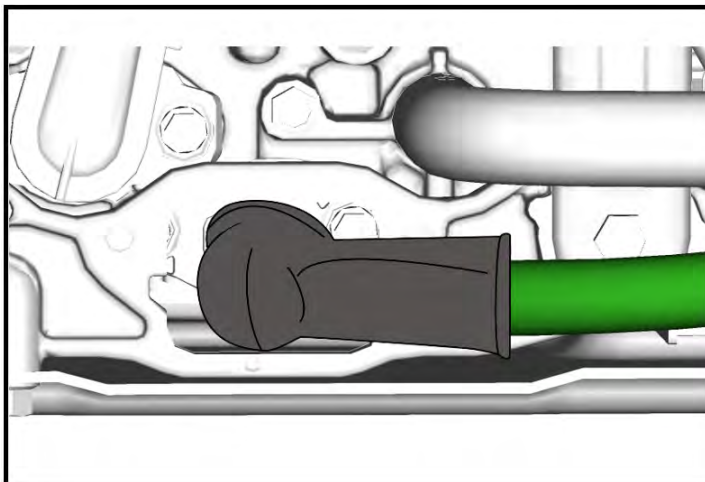

**STEP 18:** Install the inverter/converter with the three original retaining clips, three original rivet spacers, and three NEW rivets.

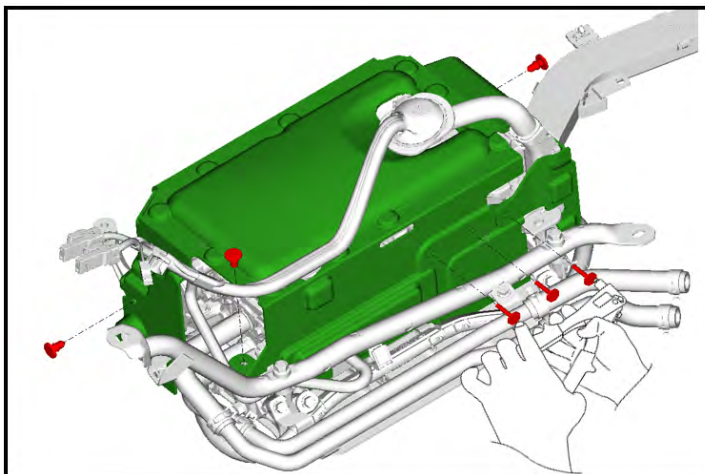

**STEP 19:** Reinstall all parts in the reverse order of disassembly.

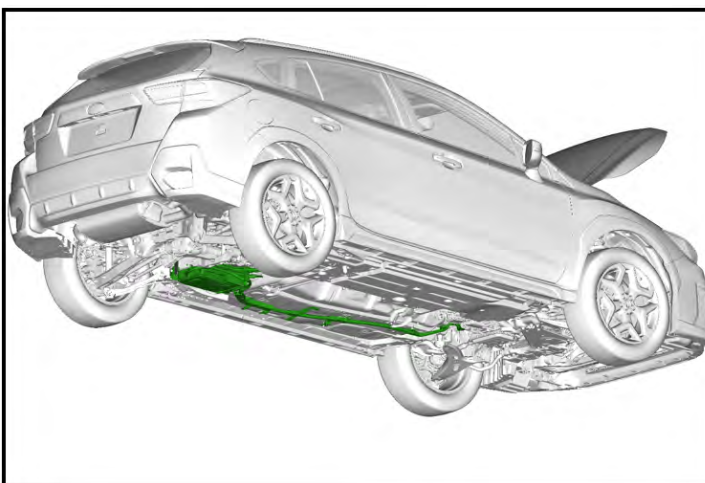

*Continued...*

## **SERVICE PROCEDURE B:**

### **WHEN CORROSION, RED RUST, AND/OR BREAKAGE IS FOUND DURING INSPECTION.**

#### **PRECAUTIONARY INFORMATION:**

- When working on high voltage systems, always wear high voltage insulated gloves.
- During disassembly and reassembly of the inverter/converter assembly, **BE CAREFULL** not to cause or induce any static electricity.
- **ALWAYS** place the inverter/converter assembly and any other removed electronic components on an antistatic work mat after removal.
- Keep any foreign matters such as water and dust from entering the inverter/converter assembly.
- Be **CAREFULL** not to make contact with the electronic components within the inverter/converter assembly.

**STEP 1:** Remove the inverter/converter assembly from the body of the vehicle using the work procedures outlined in the applicable Service Manual. Refer to STIS: Body & Electrical/WIRING SYSTEM > HYBRID ELECTRIC VEHICLE > Inverter and Converter Assembly

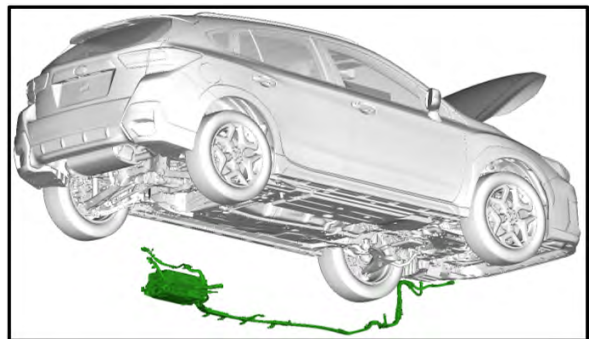

**TIP 1:** **ALWAYS** perform the required voltage checks as outlined in the Service Manual. A zero-voltage reading at these required points is vital for confirming safe working conditions.

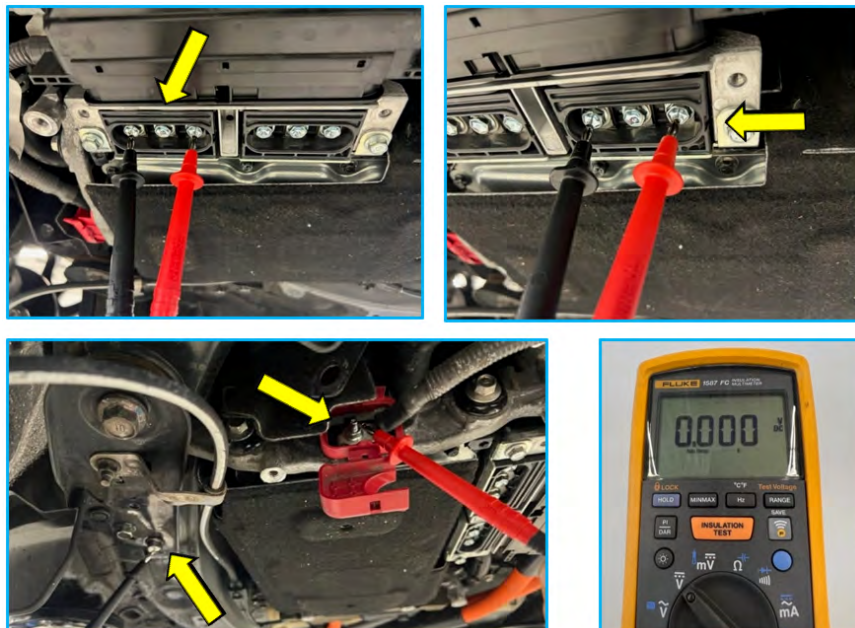

*Continued...*

**CAUTION:** ALWAYS wear high voltage insulation gloves when performing the voltage checks.

**TIP 2:** Removing the ECM provides additional cable slack when working in the upper and lower engine area during removal of the HV air conditioning cable.

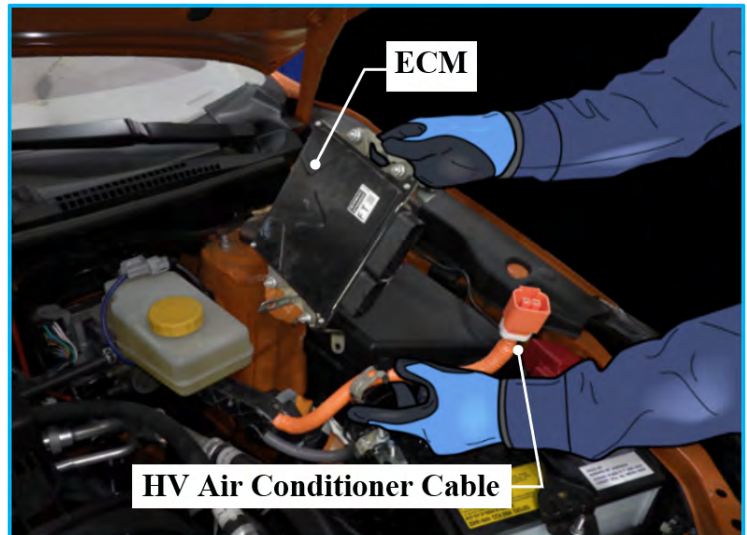

**STEP 2:** Remove the three retaining clips and the three rivets. The inverter/converter insulation cover can then be removed.

**CAUTION:**

- Release the rivets with a drill for removal. To prevent any damage to the inverter/converter assembly, support the back side of the rivet with a trim tool or pliers.
- The spacers attached to the cover **MUST** be reused. **DO NOT** discard the spacers.

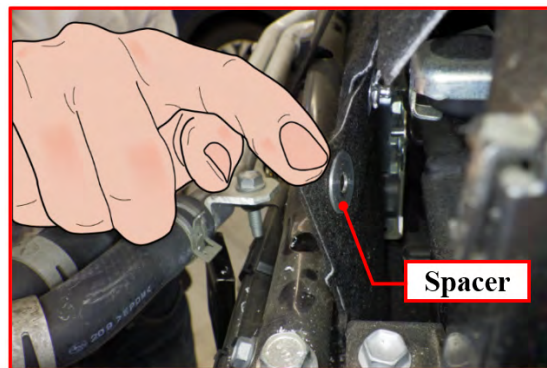

**STEP 3:** Remove the two HV air condition cable mounting bolts. Release the retaining clip and move the HV air conditioning cable to allow room for workspace.

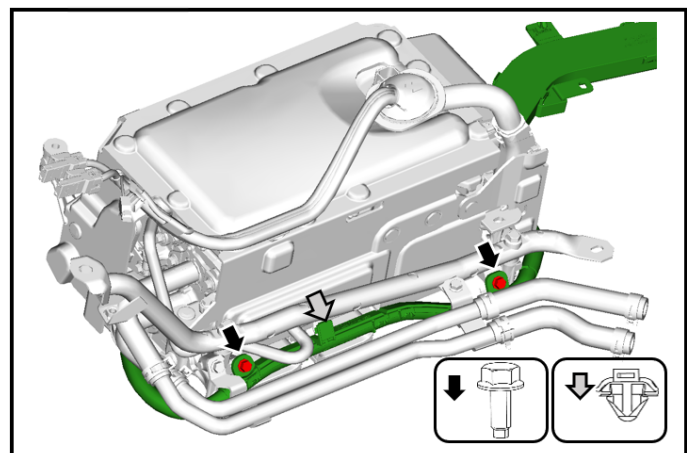

*Continued...*

**STEP 4:** Remove and discard the terminal cap or protective rubber boot.

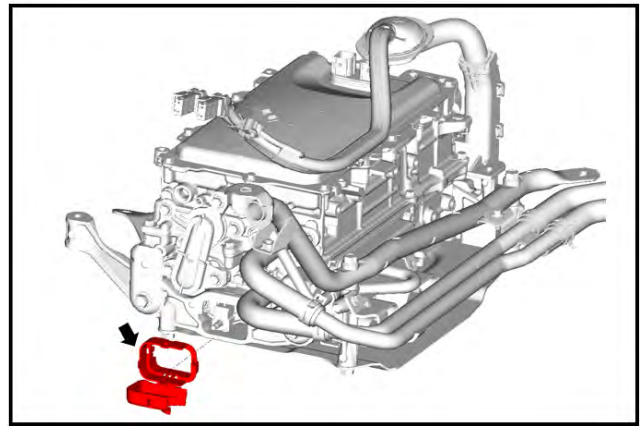

**STEP 5:** Remove the hose clamps from the connections indicated with yellow arrows in the right image. Remove the two water pipe mounting bolts. Install provided rubber caps onto the aluminum pipes to prevent any coolant drippage while working. The water pipe can then be lowered to allow access to the inverter/converter assembly.

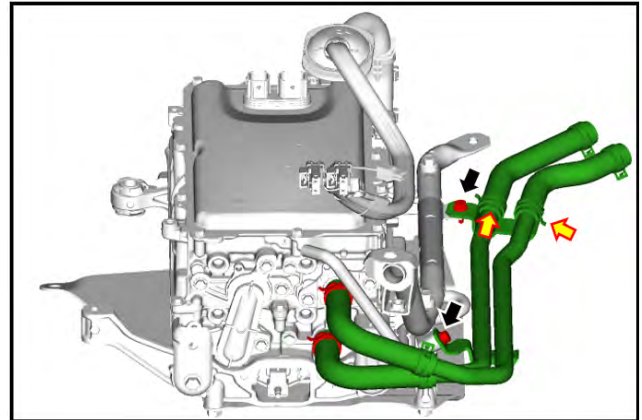

**NOTE:** The following images show the water pipes removed from the inverter/converter assembly in order to provide more detail for instructional purposes.

**STEP 6:** Remove the five inverter protector mounting bolts. The inverter protector can then be removed.

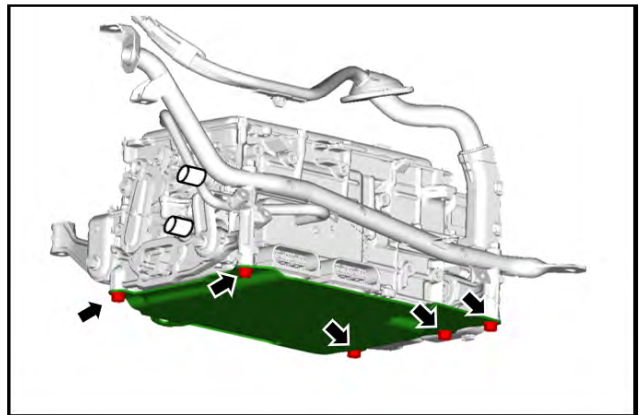

**STEP 7:** Place the inverter/converter assembly on two wooden blocks.

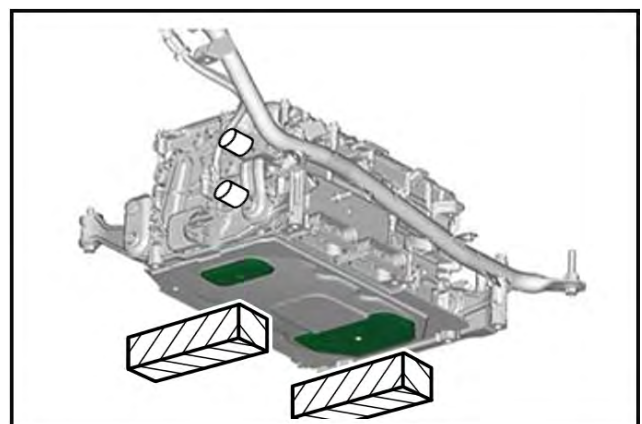

*Continued...*



**STEP 8:** Remove the two mounting bolts for the inverter stay. The stay can then be removed.

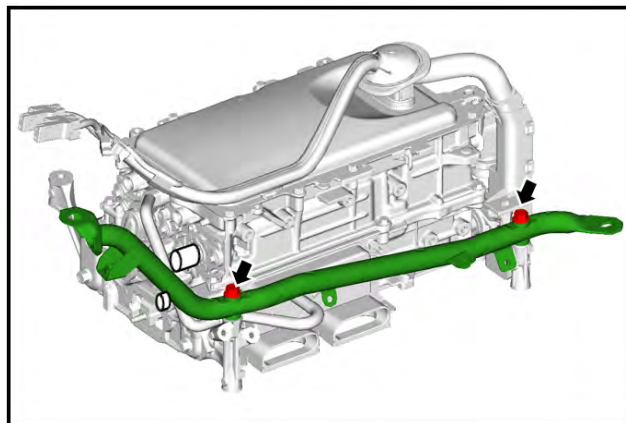

**STEP 9:** Remove the mounting bolts and stays holding the rear inverter bracket. The rear bracket assembly can then be removed.

**IMPORTANT NOTE:** The mounting bolts are one-time use parts and can be discarded. The stays are NOT to be discarded and MUST be re-used.

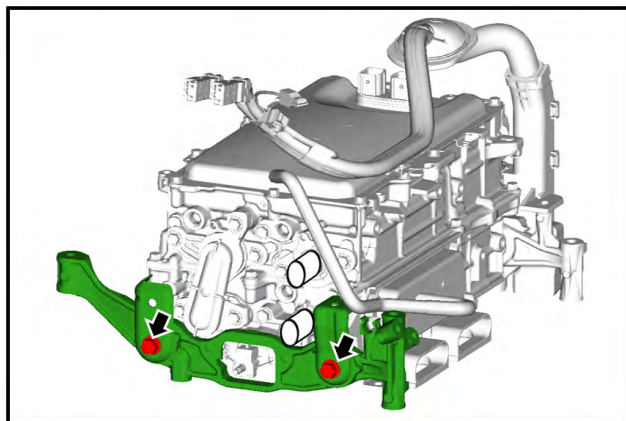

**IMPORTANT:** Insulated tools and gloves MUST be used for STEPS 10, 11, & 14.

**STEP 10:** Remove the three mounting bolts for the main battery connector. The connector can then be removed.

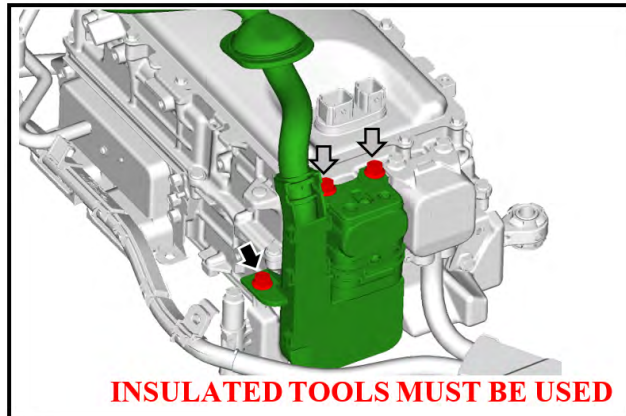

**STEP 11:** Remove the two mounting bolts for the HV air conditioning cable. The HV air conditioning cable can then be removed and discarded.

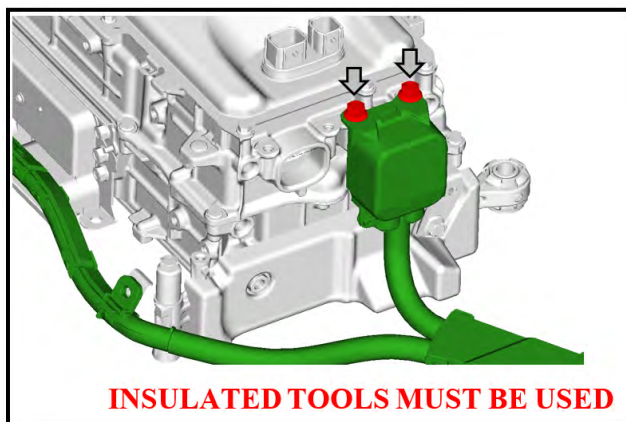

*Continued...*

**STEP 12:** Remove the two mounting bolts for the front inverter/converter bracket assembly. The bracket assembly and insulator can then be removed.

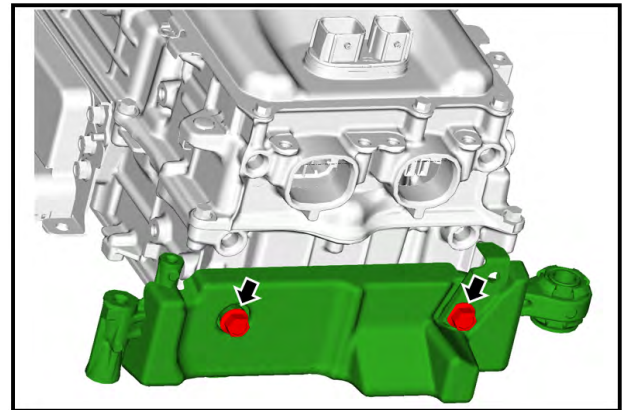

**STEP 13:** Remove the two mounting bolts for the terminal block cover. The terminal block cover can then be removed.

**CAUTION: DO NOT TOUCH** the center screw of the terminal block cover.

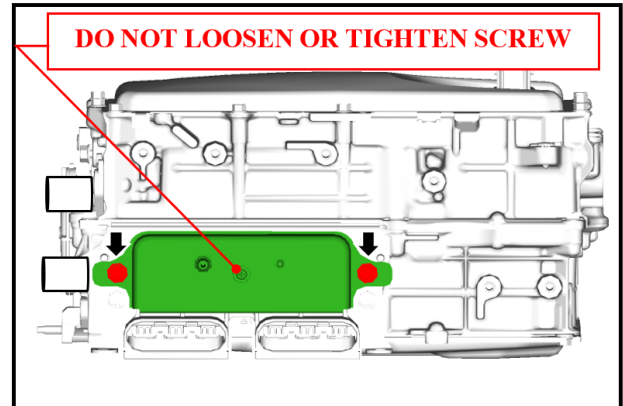

**STEP 14:** Remove the ten mounting bolts for the motor cable terminal block. The motor cable terminal block can then be removed.

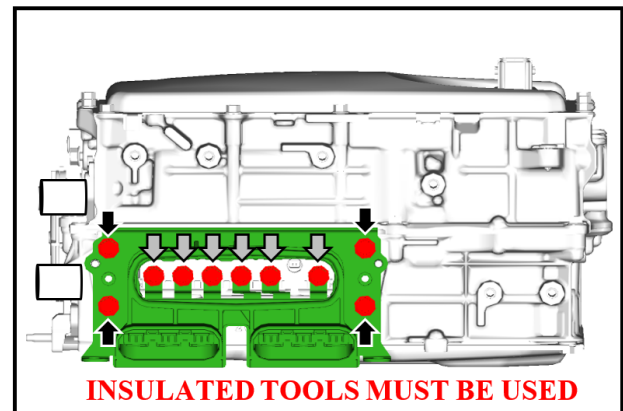

**STEP 15:** Cover the opening of each electrical connection with masking tape. This will reduce the risk of foreign matter intrusion.

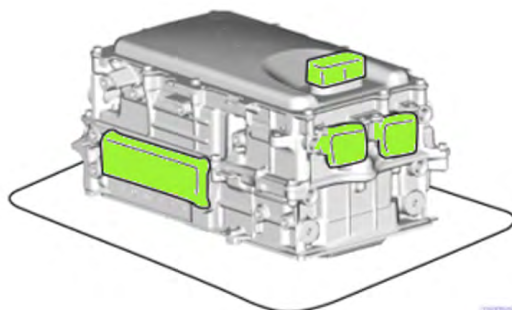

3M™ High Performance Green Masking Tape 401+ can be used for this procedure

*Continued...*

**STEP 16:** Rotate the inverter/converter assembly so the 12v terminal is facing upward.

**STEP 17:** Place the inverter/converter assembly on two wooden blocks. Align the bolt head of the cover with the wooden blocks. **DO NOT** place the block directly on the cover.

**CAUTION: CAREFULLY** place the inverter/converter assembly on the wooden blocks as shown in the images provided below in order to prevent any damage to the connector and cover.

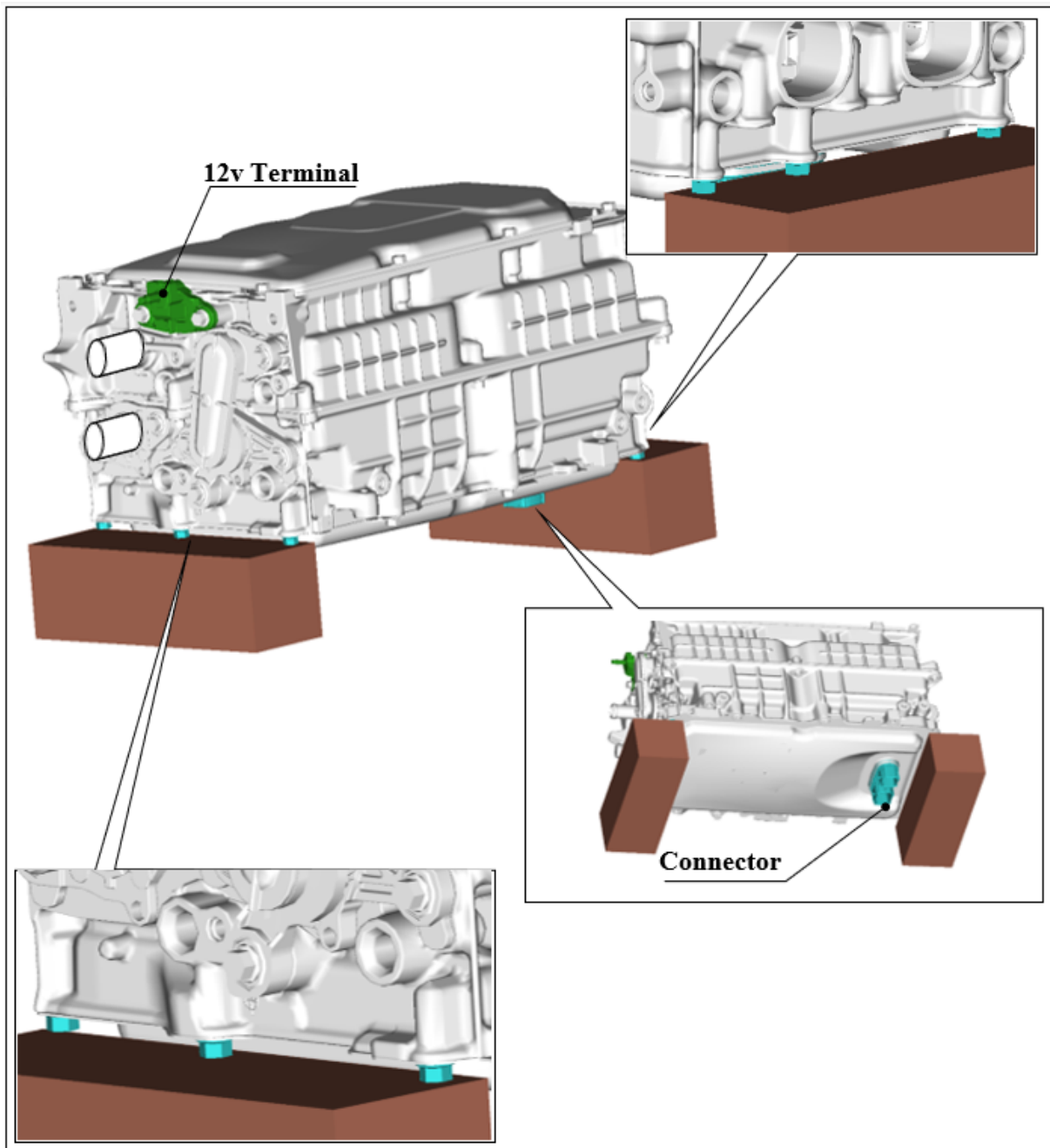

*Continued...*

**STEP 18:** Remove the eight mounting bolts front the converter lid. Prepare a small flathead screwdriver with tape wrapped around the blade. **CAREFULLY** remove the inverter/converter lid as shown in the images below.

**EXAMPLE**

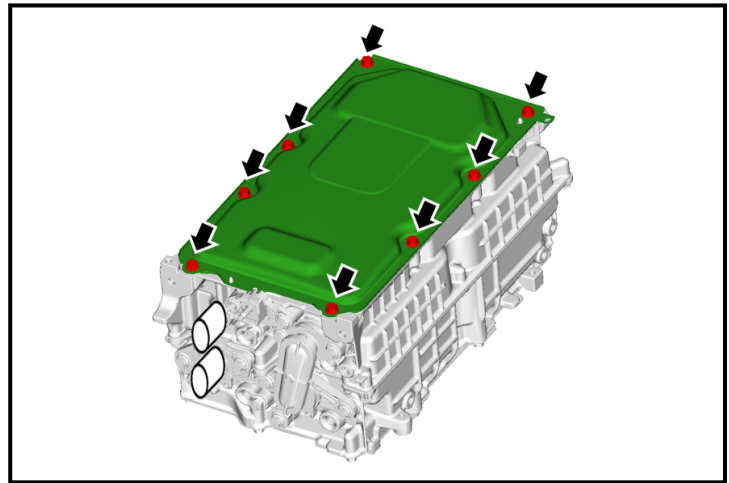
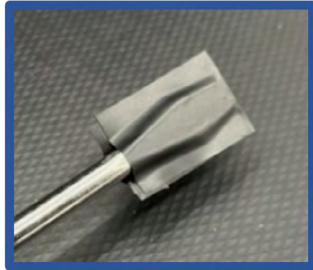

**IMPORTANT CAUTIONS:**

- **DO NOT** damage the sealing surface of the inverter/converter assembly.
- **DO NOT** lift the screwdriver handle in the upward direction. **ONLY** push the handle of the screwdriver in the downward direction when inserted between the lid and case.
- **ONLY** insert the blade portion of the screwdriver between the lid and case. Deep insertion of the screwdriver can cause damage to the case and internal components.
- **Work with bare hands or insulated gloves in order to prevent any static electricity and foreign mater intrusion into the internal electrical components.**

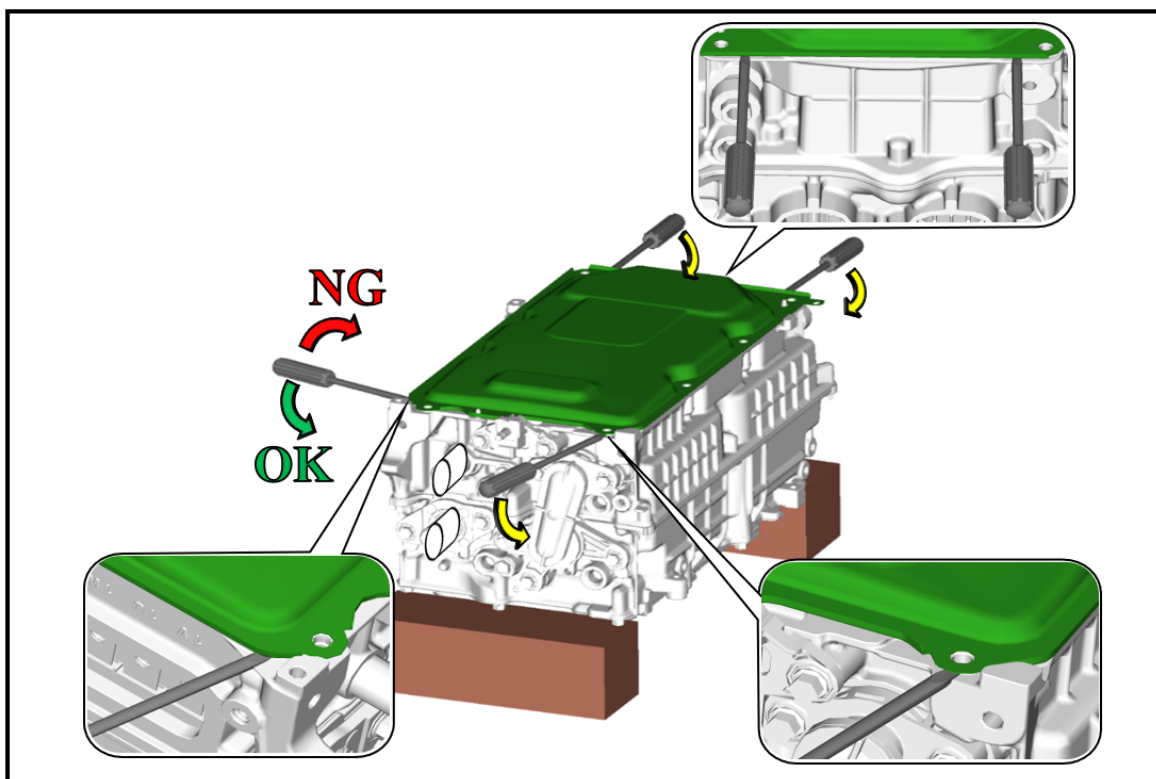

*Continued...*

**STEP 19: CAREFULLY** retrieve any sealant that may have dropped into the case. **DO NOT** touch any of the internal components. Remove the three mounting bolts for the 12v terminal.

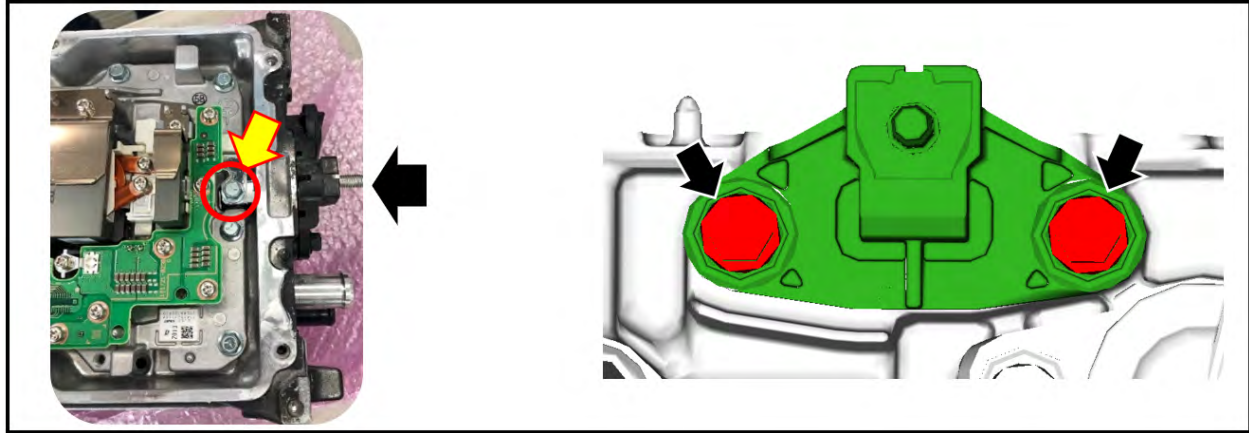

Once the mounting bolts are removed, pull the terminal away from the case to remove.

**CAUTION:** Confirm the original seal is removed with the terminal and is not left inside the case.

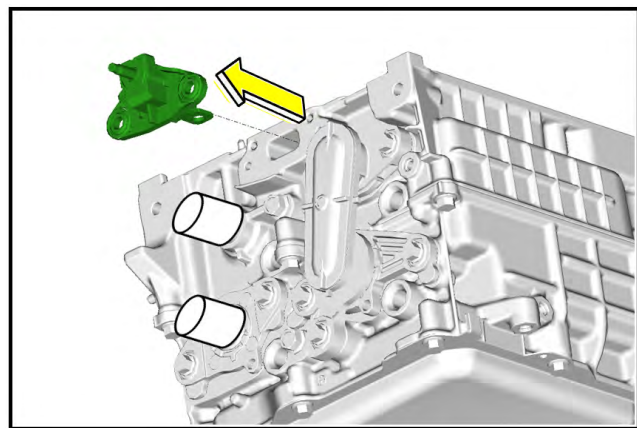

**STEP 20: CONFIRM** the seal is free of debris then install the NEW 12v terminal supplied in the terminal output kit (p.n. SOA635176) by aligning the location pins on the terminal. Torque the **INNER** mounting bolt to 5Nm (3.7ft-lbs). Torque the **OUTER** mounting bolts to 6Nm (4.4ft-lbs).

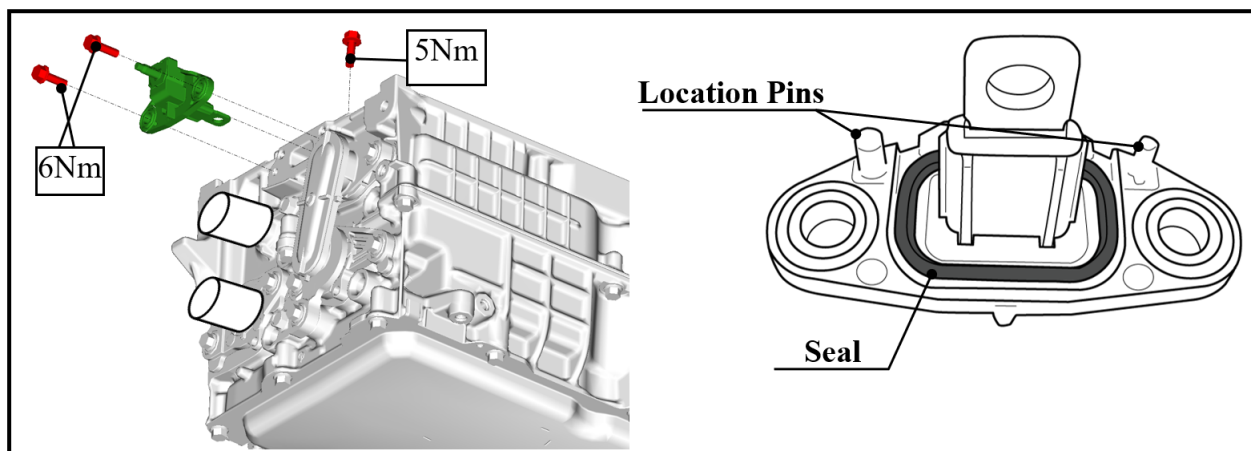

*Continued...*

**CAUTION: CONFIRM** the bus bar portion of the 12v terminal is not positioned on top of the bus bar located inside the case.

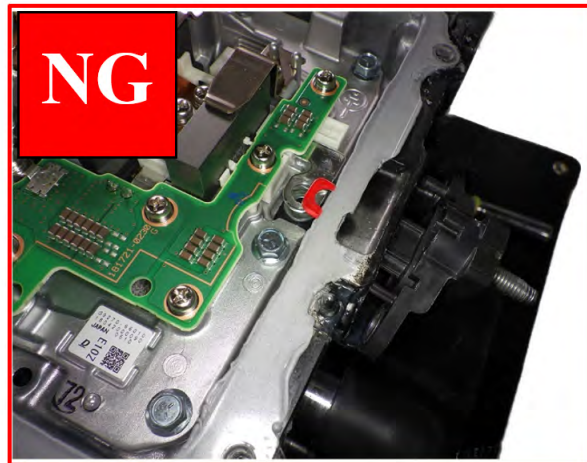
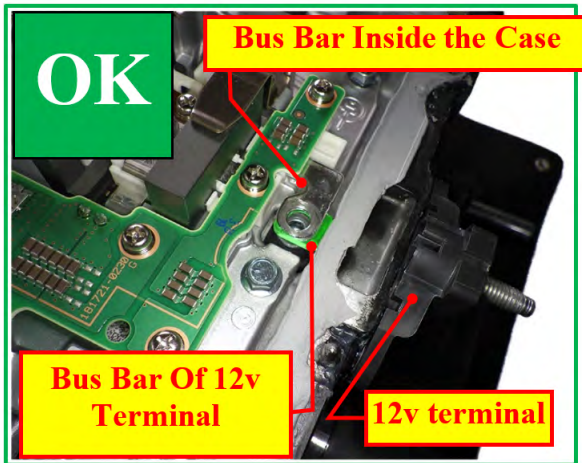

**STEP 21:** Detach the scraper from the prevention cover (**From Kit # SOA635176**). Discard the scraper since it is not to be used for this procedure.

Supplied in Kit #  
SOA635176

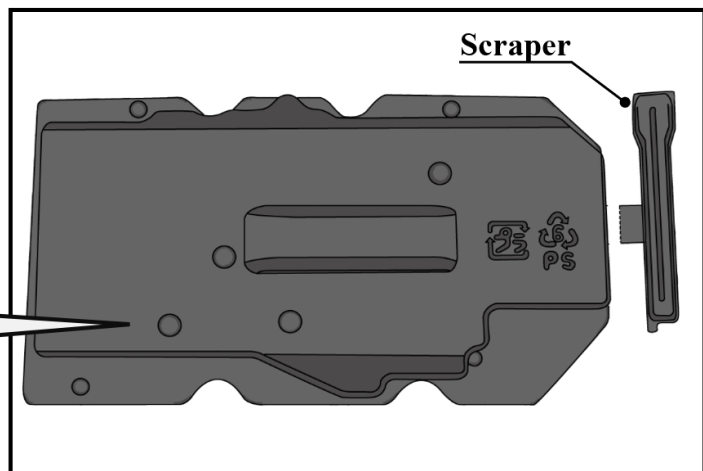

**STEP 22: CONFIRM** no sealant has dropped into the case.

**STEP 23:** Rotate the inverter/converter assembly with the terminal block connection facing upward. This position will help prevent removed sealant from entering the internal case.

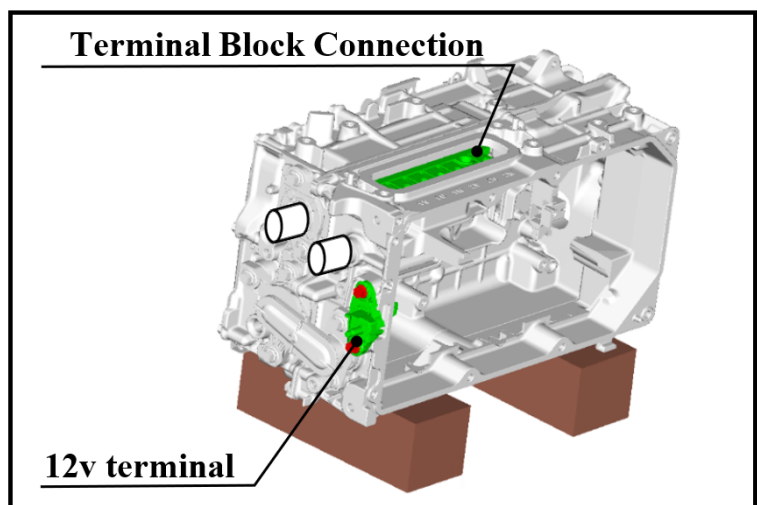

*Continued...*

**STEP 24:** Install the sealant drop prevention cover and secure it with masking tape.

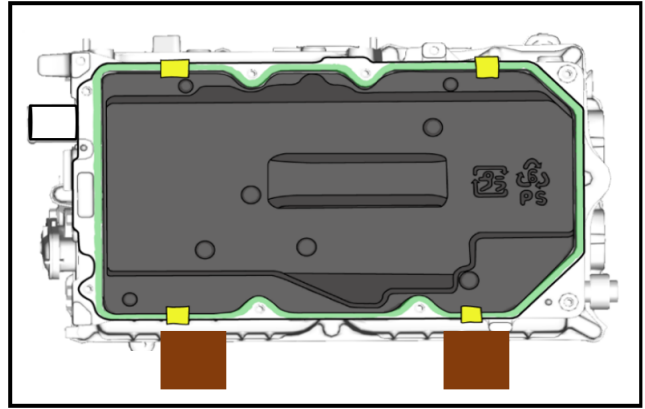

**STEP 25:** Using a suitable plastic scraper or plastic razor blade, removed any sealant adhered to the case sealing surface. ONLY the protruding sealant is required to be removed. Thin amounts of sealant without protrusions do not have any affect on the sealing performance.

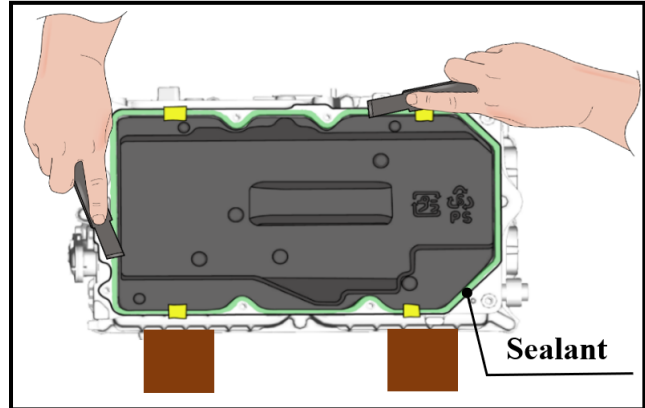

**STEP 26:** Remove residual sealant fragments with the adhesive side of masking tape.

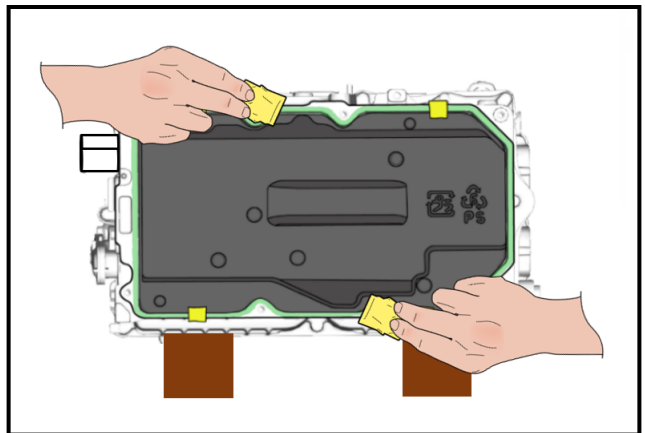

**STEP 27:** Clean the surface area with a clean cloth.

**CAUTION: DO NOT use a blow gun or brake/parts cleaner. This can cause damage to the inverter/converter internals and cause insufficient sealant curing.**

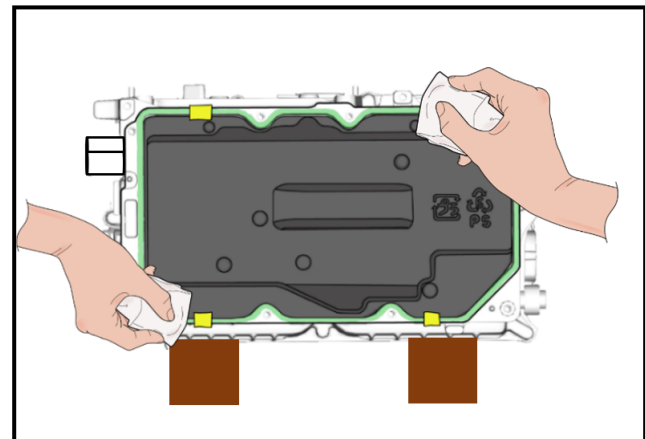

*Continued...*

**STEP 28:** Once the sealant has been sufficiently removed and the sealing surface is clean and free of debris, rotate the inverter/converter with sealing surface facing upward.

**CAUTION: CONFIRM the inverter/converter is positioned with the mounting bolts on the wooden blocks. DO NOT cause any damage to the connector or cover.**

**STEP 29:** Remove any masking tape securing the prevention cover to the case.

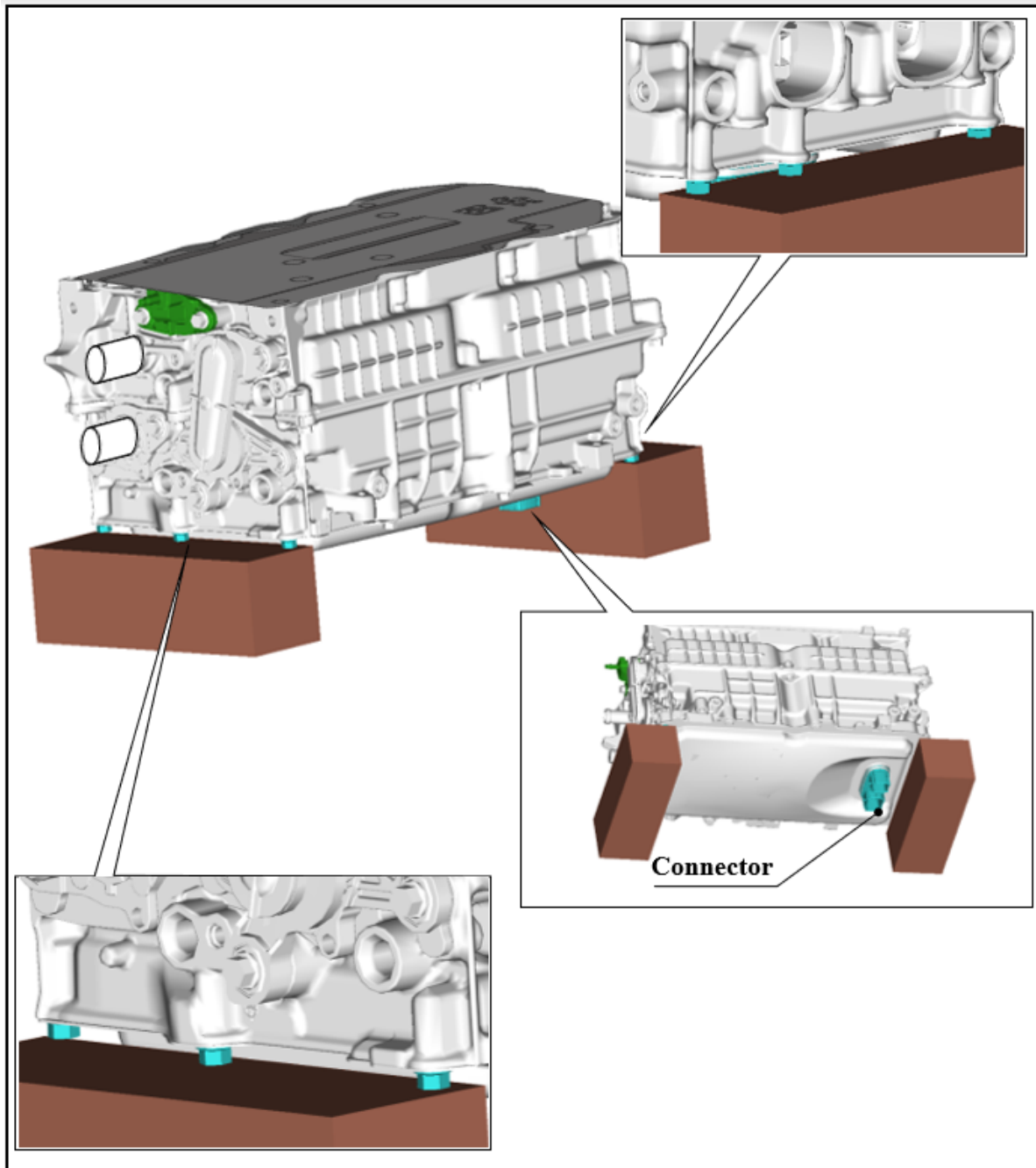

*Continued...*



**STEP 30:** Apply a 3mm (0.12in) diameter bead of Three Bond 1207F as detailed in the images below.

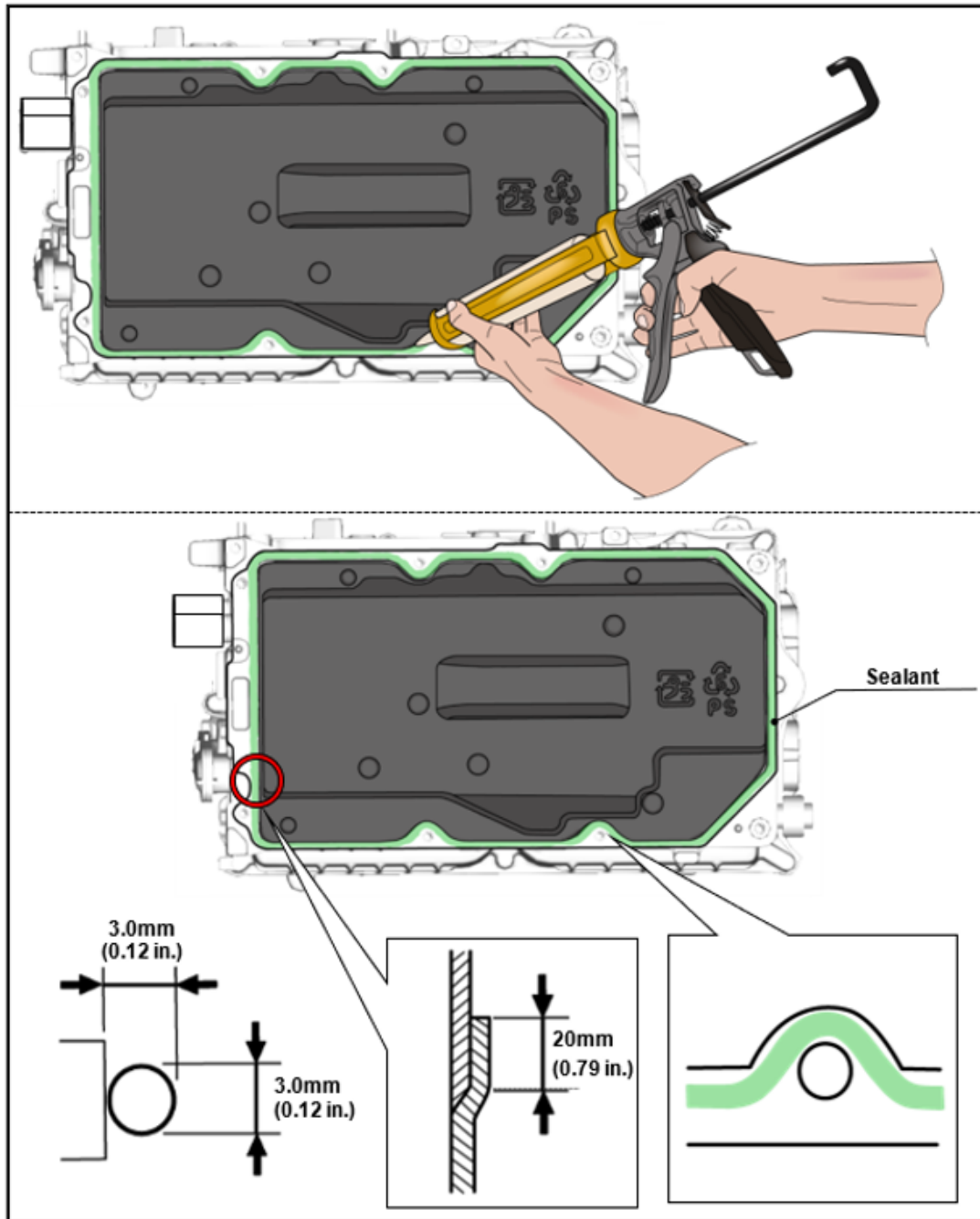

**STEP 31:** Remove the sealant drop prevention cover.

**NOTE:** The sealant drop prevention cover is NOT a one-time use tool and is designed for repeated usage. It is important to keep the cover clean and sealant free for future usage.

*Continued...*

**STEP 32:** Install the inverter lid. Install the eight mounting bolts by hand. Torque the bolts to 7.3Nm (5.4ft-lbs) in the order specified in the right image.

**STEP 33:** Perform the torques sequence a second time.

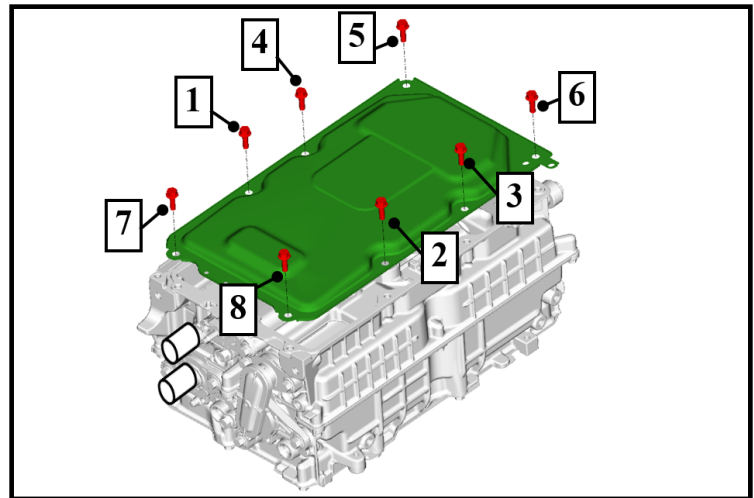

**CAUTIONS:**

- **The inverter lid MUST be installed within three minutes after the Three Bond application.**
- **The torques procedures MUST be performed within three minutes after the Three Bond application.**
- **Three Bond 1207F requires 24 hours to become fully cured. The vehicle MUST not be exposed to heavy moisture such as car wash, rain, and snow until this 24-hour cure time is complete.**

**STEP 34:** Rotate the inverter/converter assembly on the wooden blocks as shown in the image below.

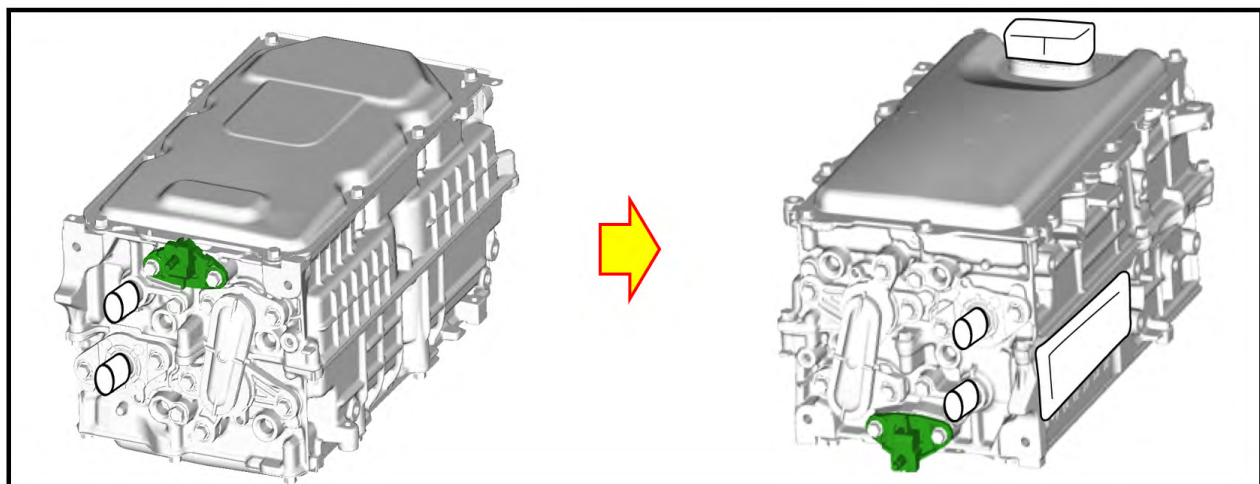

*Continued...*

**STEP 35:** Remove the masking tape from the electrical connections. Prepare the following specialty tools.

1. Connector Holder 1 (p.n.81911FL010)
2. Connector Holder 2 (p.n.81911FL050)
3. Connector Holder 3 (p.n.81911FL030)
4. Connector Holder 4 (p.n.81911FL030)
5. Repair Tool (p.n.99804AN030)
6. Flange Bolts (p.n.010406200)
7. Flange Bolts (p.n.010406120)

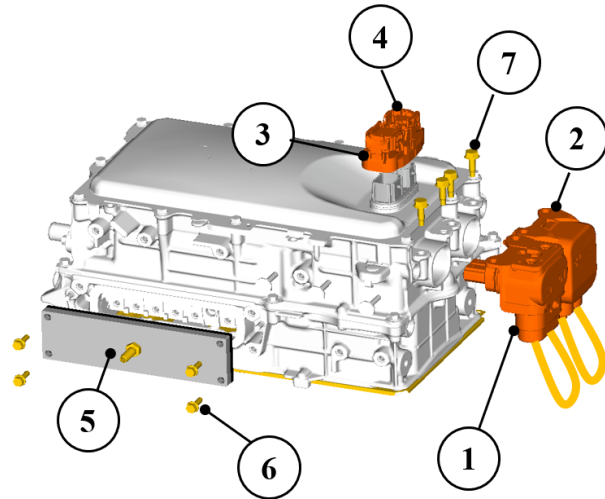

**STEP 36:** Mark the bolt heads of the Flange Bolts (p.n.010406200) and (p.n.010406120) for identification and to prevent possible mixing with any original equipment hardware.

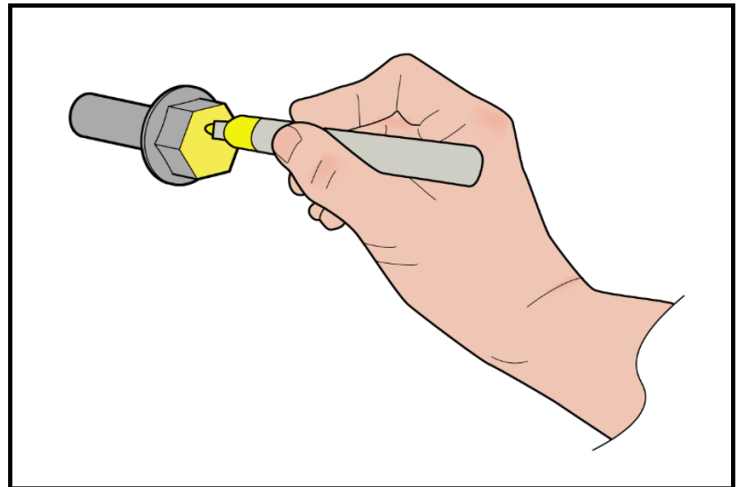

**STEP 37:** Install the Repair Tool (p.n.99804AN030) using the four Flange Bolts (p.n.010406200) in place of the motor cable terminal block connection. Tighten the bolts in an X-Pattern and torque to 5Nm (5Nm (3.7ft-lbs).

**CAUTION: DO NOT use the originally supplied bolts used for the motor cable terminal block. CAREFULLY tighten the bolts evenly. Uneven tightening may cause incorrect leak detection results.**

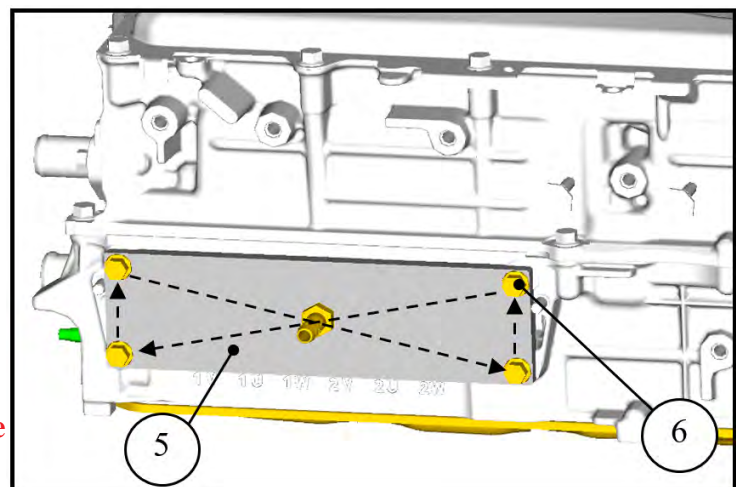

*Continued...*

**STEP 38:** Install Connector Holder 1 (p.n.81911FL010) and Connector Holder 2 (p.n.81911FL050) in place of the main battery cable connection and the HV air conditioning cable connection. Secure the Holders using the four Flange Bolts (p.n.010406120). Torque the Flange Bolts to 5Nm (5Nm (3.7ft-lbs).

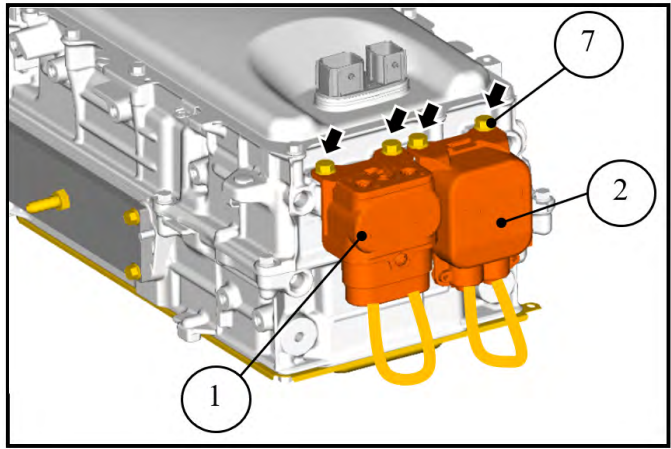

**STEP 39:** Install Connector Holder 3 (p.n.81911FL030) and Connector Holder 4 (p.n.81911FL030) in place of the upper HV air conditioning connection.

**CAUTION: CONFIRM the connection is secure by pressing down on the lock lever to ensure it is fully locked. An unsecure connection may cause incorrect leak detection results.**

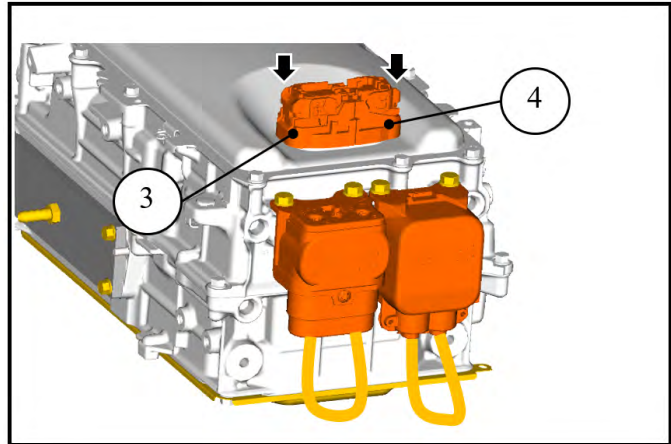

**STEP 40:** Insert the provided silicon hose nozzle of the portable leak detector.

**NOTE:** The inner diameter of the hose is 7mm (0.28 inches).

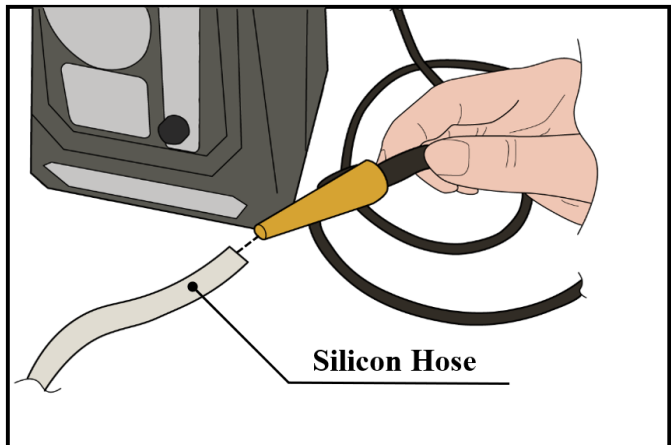

**STEP 41:** Connect the opposite end of the silicon hose to the nozzle located on Repair Tool (p.n.99804AN030).

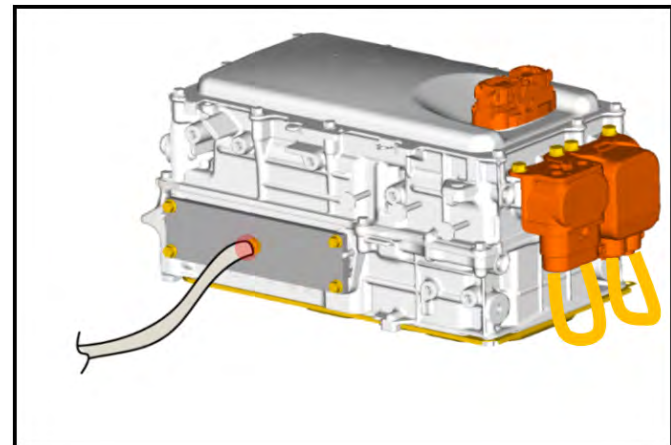

*Continued...*

**STEP 42:** Connect a 12v external power supply to the portable leak detector.

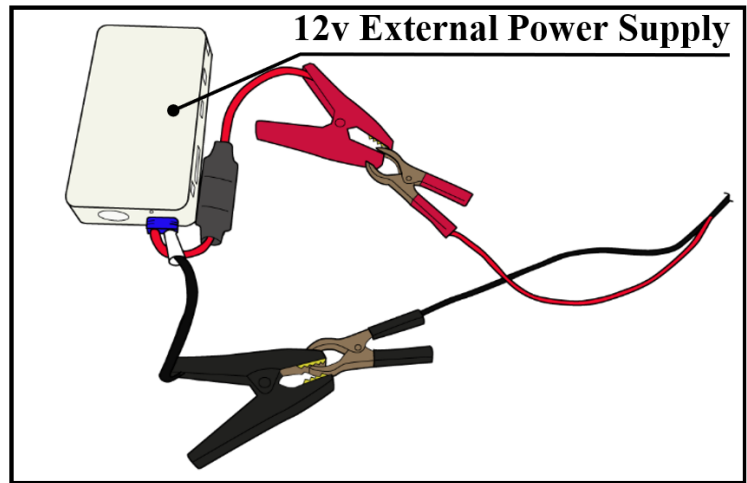

**STEP 43:** Confirm the Power LED in ON.

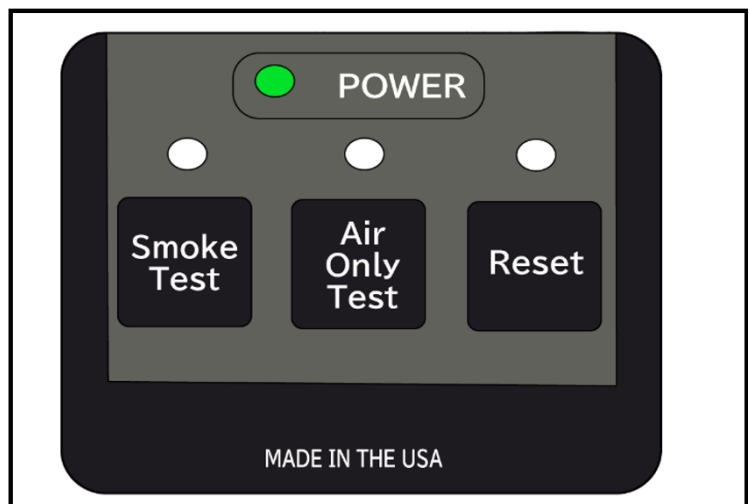

**STEP 44:** Press the “Air Only Test” button to begin the leakage test.

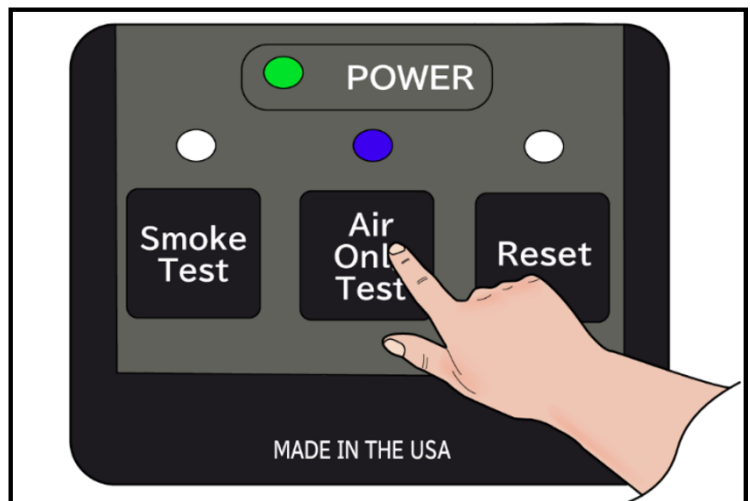

*Continued...*

**STEP 45:** During the leakage test, confirm the float stays at the bottom.

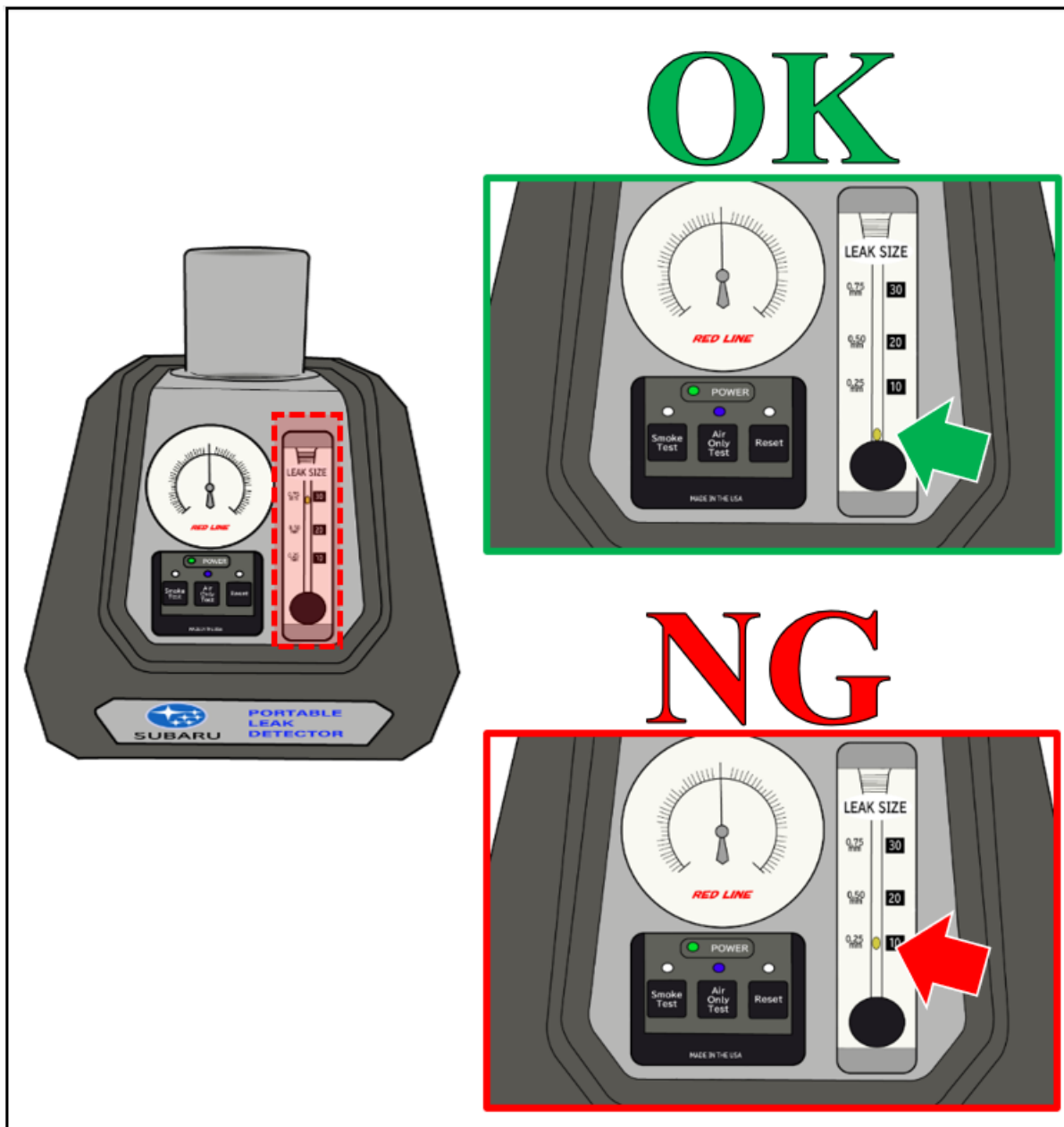

**CAUTION:** If leakage is detected, check connection conditions, the testing equipment for damage and/or deformation of the inverter/converter lid then re-test. If no visible fault is found and leakage is still found, removed the inverter/converter lid, clean and reseal the lid then retest.

*Continued...*

**STEP 46:** Apply masking tape to the mounting surfaces of the front and rear brackets. Cover the 12v terminal with masking tape. Apply the rustproof wax (3M Cavity Wax Plus) to the contact area of the inverter lid and case. Spray the area by moving the nozzle at a rate of about 50mm (2 inches) per 1 second. Perform two full rotations of application.

**CAUTIONS:**

- The rustproof wax does not completely cure. Avoid touching the wax during work procedures.
- Thoroughly shake the can prior to use. Attach the nozzle to allow optimum distribution.

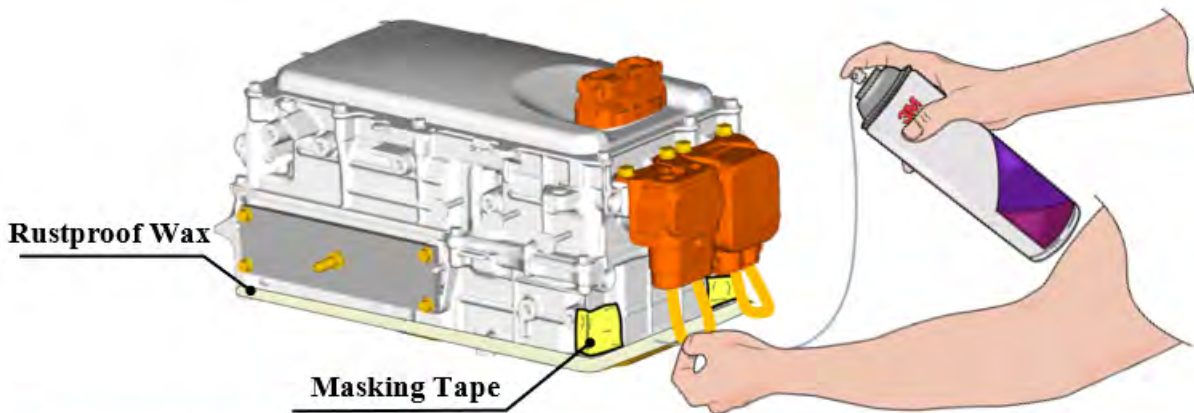

**Rustproof wax application location**

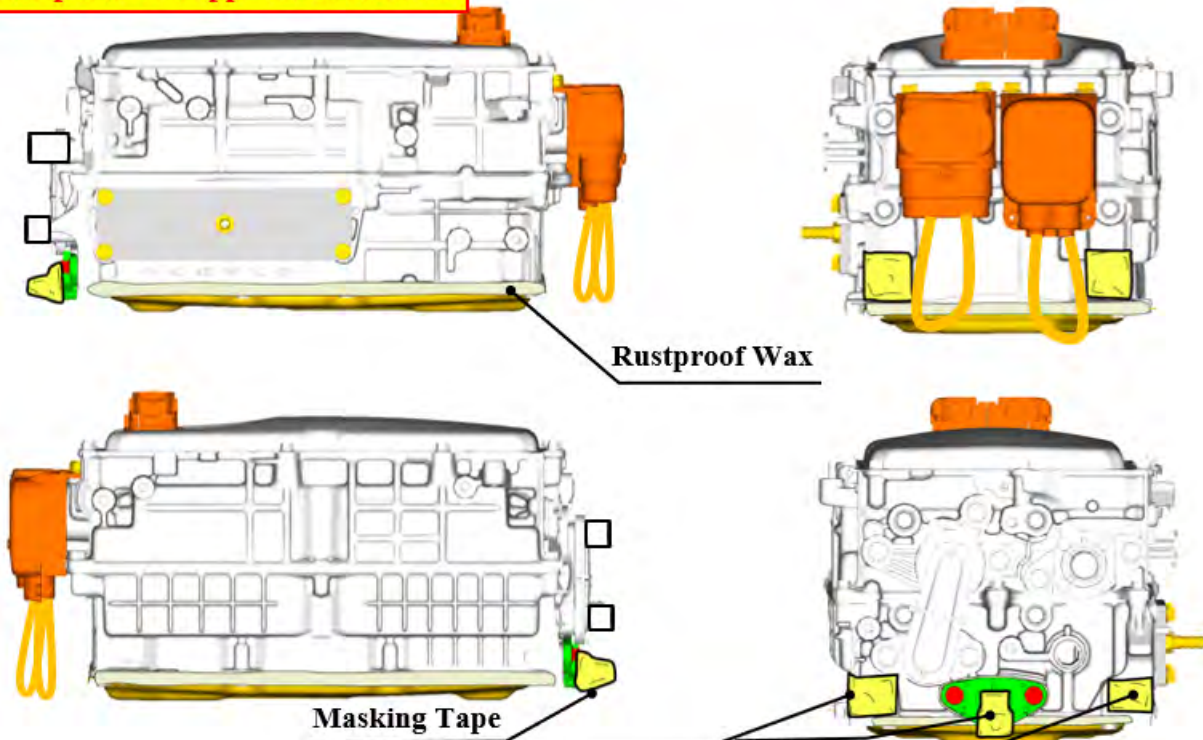

*Continued...*

**STEP 47:** Confirm there is a sufficient application of the rustproof wax. Remove all leakage testing tools and masking tape.

**CAUTION:** Clean any wax that has made contact with resin portion of the 12v terminal and/or the mounting surfaces of the front & rear brackets.

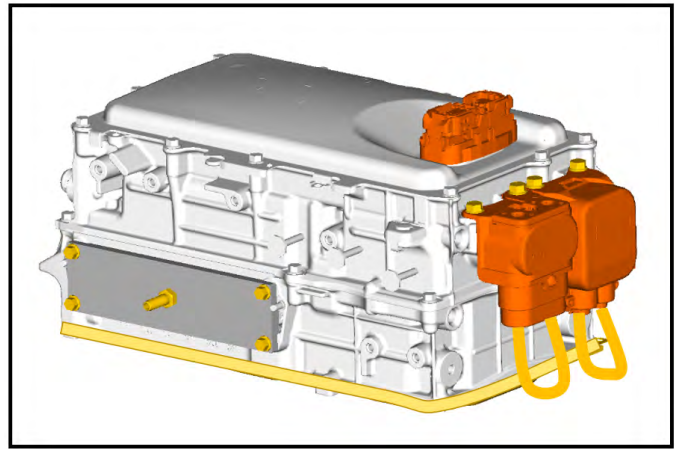

**IMPORTANT:** Insulated tools **MUST** be used for STEP 48, 51, and 52.

**STEP 48:** Install the motor cable terminal block. Torque the four outer bolts in an X-pattern to 7.5Nm (5.5ft-lbs). Torque the inner six bolts to 7.5Nm (5.5ft-lbs).

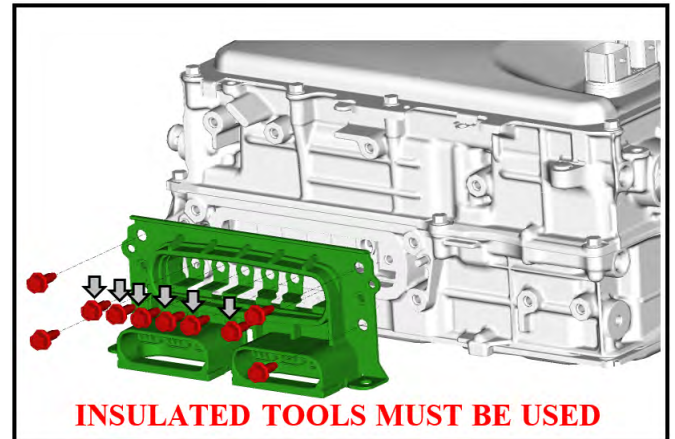

**STEP 49:** Install the terminal block cover. Torque the mounting bolts to 7.5Nm (5.5ft-lbs).

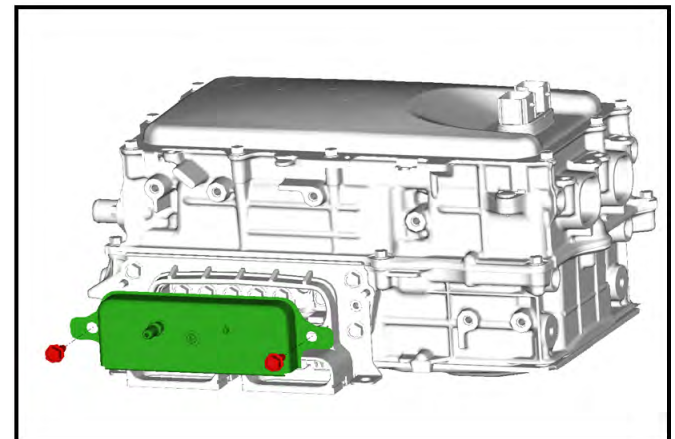

**STEP 50:** Install the front inverter/converter bracket and insulator. Torque the two mounting bolts to 18Nm (13.3ft-lbs).

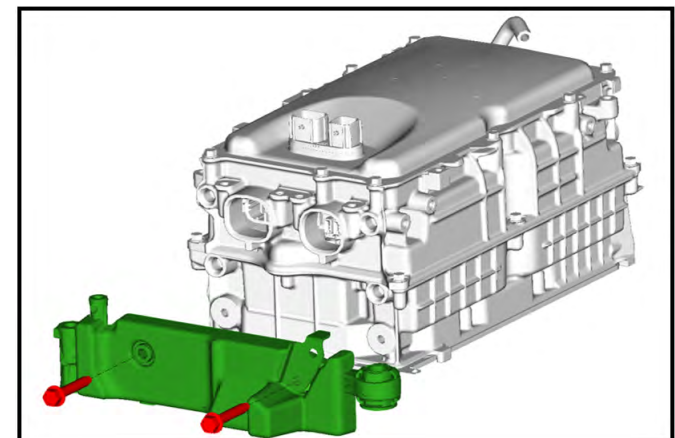

*Continued...*



**STEP 51:** Connect the NEW HV air conditioning cable. Tighten the two mounting bolts to 7.5Nm (5.5ft-lbs).

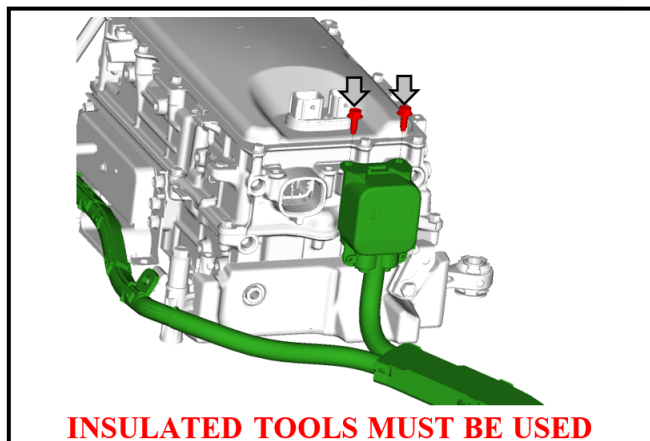

**STEP 52:** Connect the main battery cable. Torque the three mounting bolts to 7.5Nm (5.5ft-lbs).

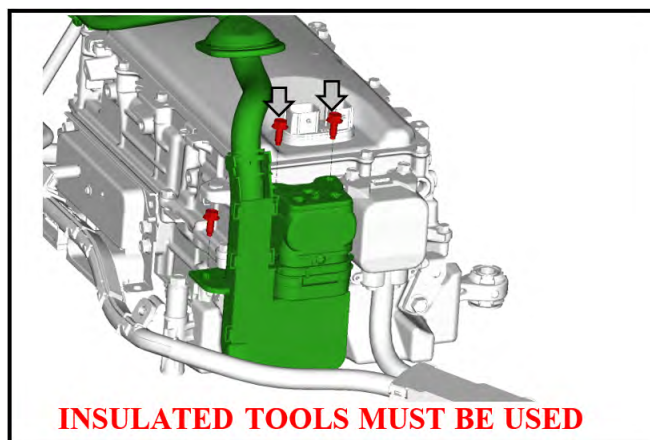

**STEP 53:** Install the NEW inverter rear bracket using NEW mounting bolts. Torque the mounting bolts to 18Nm (13.3ft-lbs).

**CAUTION: DO NOT drop or hit the new mounting bracket. This can cause the painted surface to be damaged compromising its corrosion protective strength.**

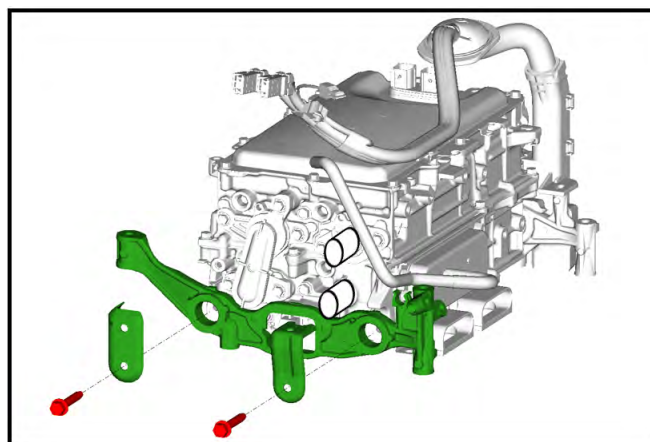

**STEP 54:** Install the inverter stay using the two original mounting bolts. Torque the mounting bolts to 18Nm (13.3ft-lbs).

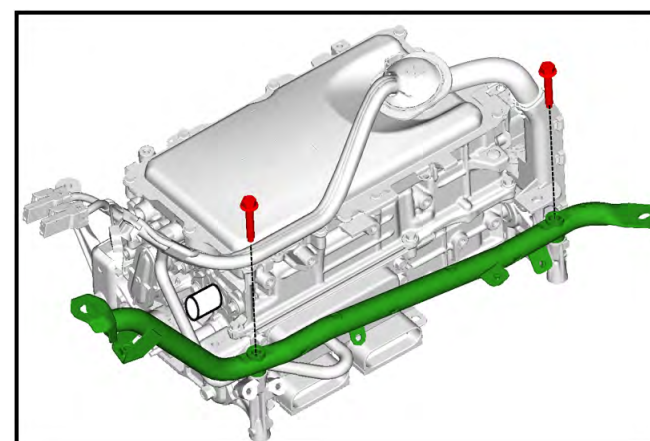

**STEP 55:** Reinstall the inverter protector with the original mounting bolts in the following order.

8. Bolt (a)

9. Bolt (b)

10. Bolts (c)

Torque the mounting bolts in the same order to 18Nm (13.3ft-lbs).

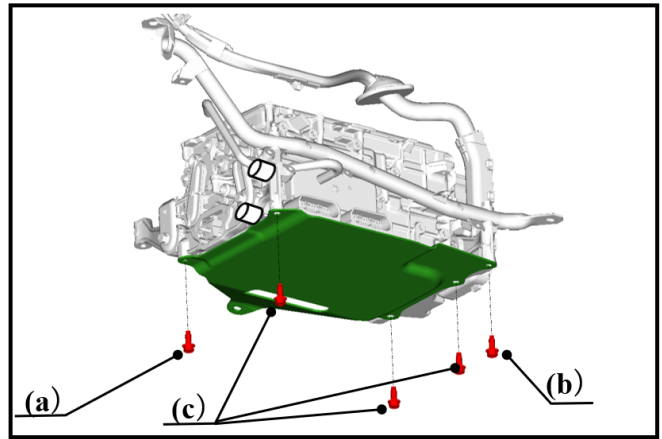

**STEP 56:** Removed the rubber caps from the water pipe. Reinstall the coolant hoses and clamps. Reattach the water pipe to the inverter/ converter assembly using the original mounting bolts. Torque the bolts to 7.5Nm (5.5ft-lbs).

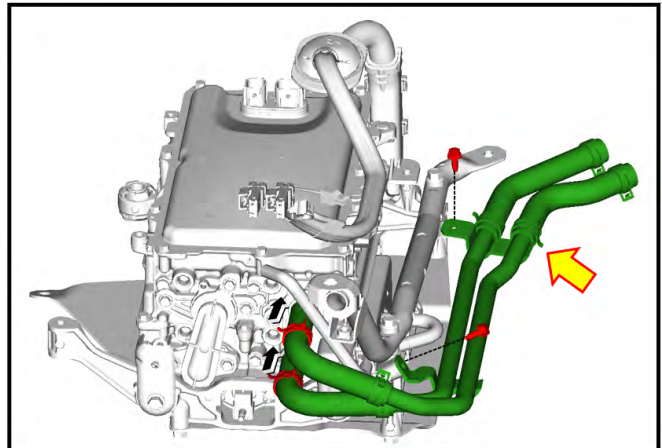

**STEP 57:** Route the HV air conditioning cable through the NEW rubber protective boot.

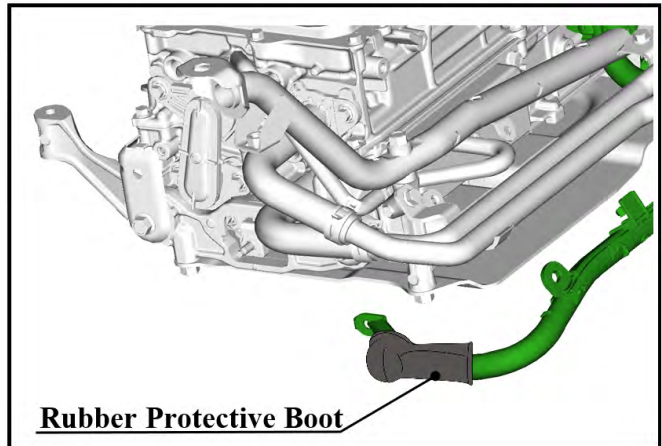

**STEP 58:** Secure the HV air condition cable to the inverter/converter using the original bolts and the new retaining clip. Torque the bolts to 7.5Nm (5.5ft-lbs).

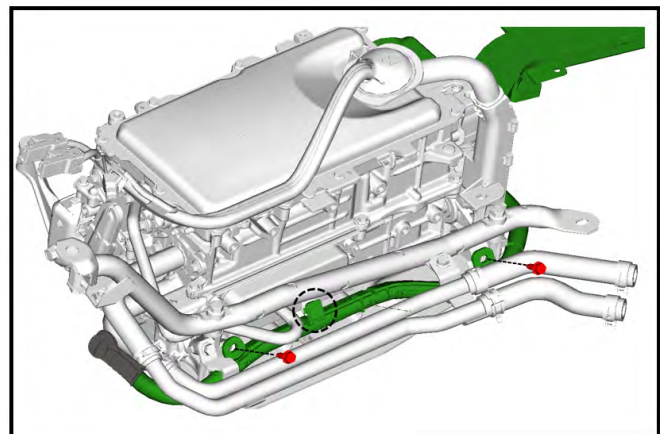

*Continued...*

**STEP 59:** Connect the HV air conditioning cable to the 12v terminal. Torque the NEW nut to 7.5Nm (5.5ft-lbs).

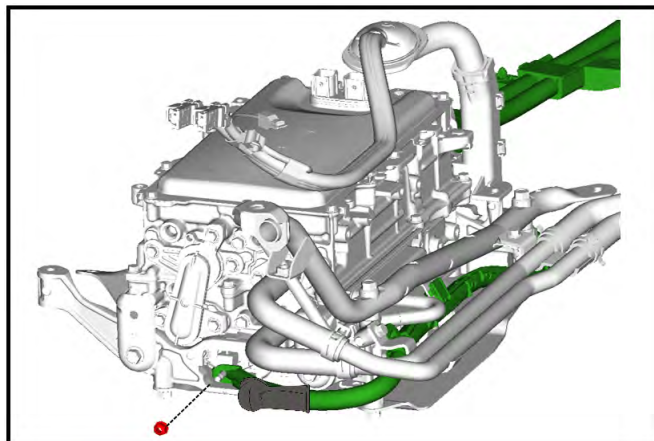

**STEP 60:** Attach the new rubber cap to the 12v terminal.

**CAUTION:** Confirm the 12v terminal is completely covered by the rubber cap. The terminal **MUST** not be exposed.

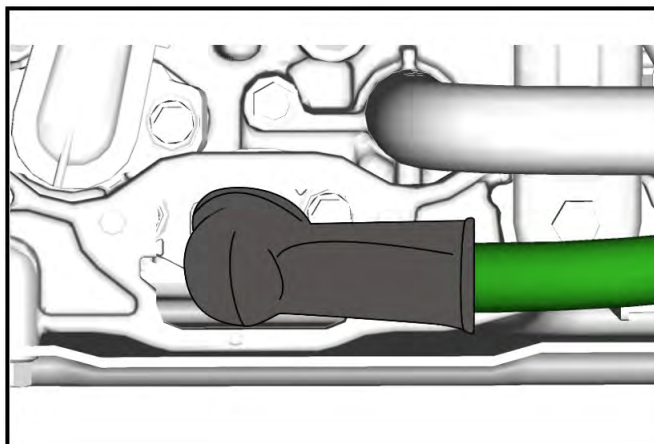

**STEP 61:** Install the inverter/converter with the three original retaining clips, three original rivet spacers, and three NEW rivets.

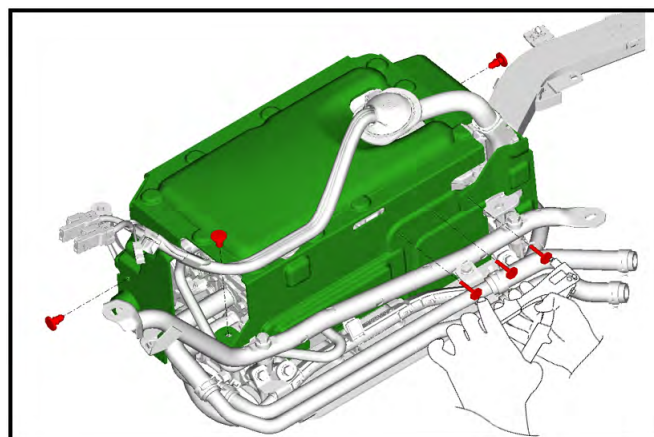

**STEP 62:** Reinstall all parts in the reverse order of disassembly.

**CAUTION:** Three Bond 1207F requires 24 hours to become fully cured. The vehicle **MUST** not be exposed to heavy moisture such as car wash, rain, and snow until this 24-hour cure time complete.

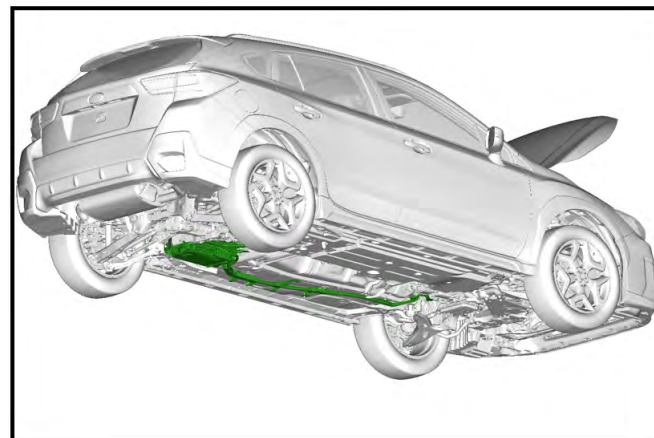

*Continued...*

## SERVICE PROGRAM IDENTIFICATION LABEL:

Type or print the necessary information on a Campaign Identification Label. The completed label should be attached to the vehicle's upper radiator support. Additional labels are available through normal parts ordering channels. The part number is **MSA6P1302**, which comes as one sheet of 20 labels.

Part Number	Applicability	Description	Order Quantity
MSA6P1302	All Models	Campaign Completion Labels (contains one sheet of 20 labels)	1

<b>SUBARU</b>
Campaign Code
<b>WRD-23</b>
COMPLETED
DIST./DEALER NO.
SERIAL NO.
<b>DO NOT REMOVE</b>

## Claim Reimbursement and Entry Procedures:

Credit to perform this recall will be based on properly completed repair order information. Retailers may submit claims through [Subarunet.com](http://Subarunet.com).

Labor Description	Labor Operation #	Labor Time	Fail Code
INVERTER CABLE TERMINAL INSPECTION AND BRACKET R&R, RUBBER CAP	A104-399	3.3	WRD-23
INVERTER CABLE TERMINAL AND BRACKET R&R, RUBBER CAP	A104-699	4.3	

**NOTE:** Up to \$5.00 can be claimed in sublet for materials used during this procedure.

## IMPORTANT REMINDERS:

- SOA strongly discourages the printing and/or local storage of service information as previously released information and electronic publications may be updated at any time.
- Always check for any open recalls or campaigns anytime a vehicle is in for servicing.
- Always refer to STIS for the latest service information before performing any repairs.

**IMPORTANT SAFETY RECALL**

This notice applies to the VIN identified in the address section printed below



PO Box 9103  
Camden, NJ 08101-9877  
844-373-6614  
www.subaru.com

**Subaru Safety Recall WRD-23**

**NHTSA ID 23V-080**

**April 2023**

**Interim Notification**

**Dear Subaru Owner:**

This notice is sent to you in accordance with the National Traffic and Motor Vehicle Safety Act.

Subaru of America, Inc. (Subaru) has decided that a defect which relates to motor vehicle safety exists in certain 2019-2022 model year Crosstrek Hybrid vehicles.

You received this notice because our records indicate that you currently own one of these vehicles.

**DESCRIPTION OF THE DEFECT AND SAFETY RISK**

The harness terminal that supplies low-voltage power from the converter to the 12V battery may corrode, and over time, could cause the terminal to break. If the terminal breaks, the 12V battery may not recharge as a result of this condition.

If the harness terminal breaks and the 12V battery is unable to recharge, the vehicle may experience a loss of motive power, increasing the risk of a crash.

**WHAT YOU SHOULD DO**

The remedy for this repair is not yet available. Subaru is in the process of preparing the tools and repair procedures for this recall and expects to have them available by July.

Once the remedy is available, Subaru will contact you again by mail advising you to proceed with scheduling an appointment with your Subaru retailer (dealer).

**WHAT SUBARU WILL DO**

Once the remedy is available, Subaru will replace the converter terminal mounting bracket with a new bracket with improved isolation at no cost to you. If there is no corrosion found on the terminals of the 12V output harness, a protective rubber cap will be installed on the terminals. If corrosion is found on the terminals, Subaru will replace the 12V output harness, including the terminals, with a new one at no cost to you.

## **OWNER INFORMATION**

Government regulations require that recall notifications be sent to the last known owner of record. That information is based primarily on state registration and title data. If you are a lessor of this vehicle, federal regulations require you to forward this notice to your lessee within ten days.

If you have moved or sold your vehicle, please go to <https://www.subaru.com/support/customer-support.html> to send us your information.

## **IF YOU HAVE PREVIOUSLY PAID FOR A REPAIR**

If you have already paid for repairs associated with this condition, you may be eligible for reimbursement. Reimbursement consideration will be based on the amount an authorized Subaru retailer in your area would charge for the same repair.

Please send the original service repair order, which has the name of the repair facility, date of repair, mileage at the time of repair, complete 17-digit vehicle identification number (VIN), and your name, with correct mailing address and telephone number to the address listed below.

**Subaru of America, Inc.**  
**Customer Advocacy Department, Attention: WRD-23 Recall**  
**P.O. Box 9103, Camden, NJ 08101-9877**

Please send original receipts only and retain a photocopy for your records. Please be assured that we will attempt to process your reimbursement request as quickly as possible, but it may take up to 60 days for this process to be completed.

## **IF YOU NEED FURTHER ASSISTANCE:**

To locate the nearest Subaru retailer, you can access our website at [www.subaru.com](http://www.subaru.com) and select 'Find a Retailer.'

For additional information, please go to: <http://www.wrd23.service-campaign.com>.

If you need additional assistance, please contact us directly:

- By e-mail: Go to [www.subaru.com](http://www.subaru.com) and select "Customer Support"
- By telephone: 1-844-373-6614  
Monday through Friday between 8:00 a.m. and 7:00 p.m. ET
- By U.S. Postal mail: Write us at Subaru of America, Inc.  
Attn: Customer Advocacy Department  
P.O. Box 9103, Camden, NJ 08101-9877

To subscribe to the NHTSA Recall Notification email System, please go to: <https://www-odi.nhtsa.dot.gov/nhtsa/subscriptions>.

Please contact us immediately if the Subaru retailer fails or is unable to make the necessary repairs free of charge.

You may also contact the Administrator, National Highway Traffic Safety Administration (NHTSA), 1200 New Jersey Ave., SE, Washington, DC 20590 or call the toll-free Vehicle Safety Hotline at 1-888-327-4236 (TTY: 1-800-424-9153) or go to <http://www.NHTSA.gov> if you believe the Subaru retailer has failed or is unable to remedy your vehicle without charge within a reasonable amount of time.

Your continued satisfaction with your Subaru is important to us. Please understand that we have taken this action in the interest of your safety and your vehicle's proper operation. We sincerely apologize for any inconvenience this matter may cause and urge you to schedule an appointment once you are notified that the remedy is available.

Sincerely,

Subaru of America, Inc.

A subsidiary of SUBARU CORPORATION

**IMPORTANT SAFETY RECALL**

This notice applies to the VIN identified in the address section printed below



PO Box 9103  
Camden, NJ 08101-9877  
844-373-6614  
www.subaru.com

**Subaru Safety Recall WRD-23**

**NHTSA ID 23V-080**

**May 2023**

**Dear Subaru Owner:**

This notice is sent to you in accordance with the National Traffic and Motor Vehicle Safety Act.

Subaru of America, Inc. (Subaru) has decided that a defect which relates to motor vehicle safety exists in certain 2019-2022 model year Crosstrek Hybrid vehicles.

You previously received a letter informing you of this safety recall, stating that the remedy was not yet available.

**This letter is to inform you that the remedy is now available.**

**DESCRIPTION OF THE DEFECT AND SAFETY RISK**

The harness terminal that supplies low-voltage power from the converter to the 12V battery may corrode, and over time, could cause the terminal to break. If the terminal breaks, the 12V battery may not recharge as a result of this condition.

If the harness terminal breaks and the 12V battery is unable to recharge, the vehicle may experience a loss of motive power, increasing the risk of a crash.

**WHAT SUBARU WILL DO**

Subaru will replace the converter terminal mounting bracket with a new bracket with improved isolation at no cost to you. If there is no corrosion found on the terminals of the 12V output harness, a protective rubber cap will be installed on the terminals. If corrosion is found on the terminals, Subaru will replace the 12V output harness, including the terminals, with a new one at no cost to you.

**WHAT YOU SHOULD DO**

Please contact your Subaru retailer (dealer) immediately for an appointment to have this repair performed, at no cost to you.



## **HOW LONG WILL THE REPAIR TAKE?**

The time required for this repair will vary depending on the service required. The repair time to replace the converter terminal mounting bracket is approximately three and a half hours; if corrosion is found on the terminals, the repair will require an additional hour to replace the 12V output harness, including the terminals.

Your retailer can provide you with a better estimate of the overall time for this service visit, as it may be necessary to leave your vehicle for a longer period of time on the day of your scheduled appointment to allow your Subaru retailer flexibility in scheduling.

## **OWNER INFORMATION**

Government regulations require that recall notifications be sent to the last known owner of record. That information is based primarily on state registration and title data. If you are a lessor of this vehicle, federal regulations require you to forward this notice to your lessee within ten days.

If you have moved or sold your vehicle, please go to <https://www.subaru.com/support/customer-support.html> to send us your information.

## **IF YOU HAVE PREVIOUSLY PAID FOR A REPAIR**

If you have already paid for repairs associated with this condition, you may be eligible for reimbursement. Reimbursement consideration will be based on the amount an authorized Subaru retailer in your area would charge for the same repair.

Please send the original service repair order, which has the name of the repair facility, date of repair, mileage at the time of repair, complete 17-digit vehicle identification number (VIN), and your name, with correct mailing address and telephone number to the address listed below:

**Subaru of America, Inc.**  
**Customer Advocacy Department, Attention: WRD-23 Recall**  
**P.O. Box 9103, Camden, NJ 08101-9877**

Please send original receipts only and retain a photocopy for your records. Please be assured that we will attempt to process your reimbursement request as quickly as possible, but it may take up to 60 days for this process to be completed.

## **IF YOU NEED FURTHER ASSISTANCE:**

To locate the nearest Subaru retailer, you can access our website at [www.subaru.com](http://www.subaru.com) and select 'Find a Retailer.'

For additional information, please go to: <http://www.wrd23.service-campaign.com>.

If you need additional assistance, please contact us directly:

- By e-mail: Go to [www.subaru.com](http://www.subaru.com) and select “Customer Support”
- By telephone: 1-844-373-6614  
Monday through Friday between 8:00 a.m. and 7:00 p.m. ET
- By U.S. Postal mail: Write us at Subaru of America, Inc.  
Attn: Customer Advocacy Department  
P.O. Box 9103, Camden, NJ 08101-9877

To subscribe to the NHTSA Recall Notification email System, please go to: <https://www-odi.nhtsa.dot.gov/nhtsa/subscriptions>.

Please contact us immediately if the Subaru retailer fails or is unable to make the necessary repairs free of charge.

You may also contact the Administrator, National Highway Traffic Safety Administration (NHTSA), 1200 New Jersey Ave., SE, Washington, DC 20590 or call the toll-free Vehicle Safety Hotline at 1-888-327-4236 (TTY: 1-800-424-9153) or go to <http://www.NHTSA.gov> if you believe the Subaru retailer has failed or is unable to remedy your vehicle without charge within a reasonable amount of time.

Your continued satisfaction with your Subaru is important to us. Please understand that we have taken this action in the interest of your safety and your vehicle’s proper operation. We sincerely apologize for any inconvenience this matter may cause and urge you to schedule an appointment as soon as possible.

Sincerely,

Subaru of America, Inc.

A subsidiary of SUBARU CORPORATION