



SAFETY RECALL

Release Date: November 17, 2022

IND

Communication #: I-22-06-A/B

Model Year(s): 2021-2022

— Confidential and Proprietary —

VERSION: R03 (April 13, 2023)

Second technician fuel connection check and Training requirement added

IMPORTANT STOP SALE SAFETY NOTICE!

Stop selling affected vehicles immediately until the repair procedure has been completed on affected units at your dealership. Federal law prohibits the sale of products subject to a recall. Selling such products could subject the seller to substantial penalties.

IMPORTANT

If you are working with a printed copy, please verify you have the most current version of this document.

SUBJECT: CHIEF AND SCOUT FUEL PUMP

PURPOSE

Indian Motorcycle has determined that some Model Year 2022 Chief and Model Year 2021-2022 Scout motorcycles may experience a failure at the fuel pump during operation. If this occurs, the engine may stall increasing the risk of a crash and serious injury.

To address this concern, Indian Motorcycle has released this safety recall with instructions to replace the fuel pump with an improved part.

AFFECTED MODELS

MODEL YEAR	MODELS	AFFECTED RANGE
2022	Chief	Reference Unit Inquiry on the dealer website or the Service Communications list on the STOP site to look up affected units.
2021-2022	Scout	

REVISION INDEX

IMPORTANT

Please review the following table as important changes have been made to this Safety Recall.

REVISION	RELEASE DATE	UPDATES
R01	11/17/2022	Initial STOP SALE Release
R02	11/22/2021	Converted from a Stop Sale to a Safety Recall
R03	04/13/2023	<ol style="list-style-type: none">1. Second technician fuel connection check and Training requirement2. Additional pictures added for clarity.3. Final inspection to check for leaks and confirm fuel level.

CUSTOMER NOTIFICATION

Dealers are required to review their sales records and make arrangements with customers for Recall completion. In addition to consumer units, dealers are required to correct any affected units in their inventory. Polaris will be mailing a notification letter to consumers affected by this Recall. Polaris will also send an email to owners for whom Polaris has a valid email address.

CONTACT POLARIS

If you have questions that are not addressed in this document, contact Indian Motorcycle Service through Ask Polaris or by phone at 877-204-3697 (US/Canada Dealers Only) / +48 775 48 1234 (International).

DEALER - WHAT TO DO?

As of November 17, 2022, **YOU MUST NOT SELL OR DELIVER** any affected **NEW OR USED Model Year 2021–2022 Scout or 2022 Chief models** affected by this **Stop Sale** until it is repaired according to the **Safety Recall**.

WARRANTY CLAIM INFORMATION

2022 CHIEF FUEL PUMP	
Bulletin #	I-22-06-A
Claim Type	SB (Service Bulletin)
Labor Allowance	1.0 hours (60 minutes)
Part Number / Description	2522501 (QTY 1) Pump, Fuel 5414830 (QTY 1) Seal 7080138 (QTY 1) Tie, Cable
Parts Availability	Available to order
University of Polaris Video Training Required	Yes ¹

¹Polaris requires one person from a dealership to be certified before parts ordering may occur and two people from a dealership to be certified before warranty claims may be processed.

Claim Submission:

- **US / Canada Dealers:** On DEX, go to Service and Warranty > Warranty Claim and Extended Coverage > Start a New Warranty Claim. Select Service Bulletin> Enter the VIN / PIN and Retrieve Registration. Select I-22-06-A and Send Claim.
- **International Dealers:** On iDEX, go to Service and Warranty> Warranty Claims>Start a New Warranty Claim. Select Service Bulletin> Enter the VIN / PIN and Retrieve Registration. Select I-22-06-A and Send Claim

2021-2022 SCOUT FUEL PUMP	
Bulletin #	I-22-06-B
Claim Type	SB (Service Bulletin)
Labor Allowance	1.0 hours (60 minutes)
Part Number / Description	2521733 (QTY 1) Pump, Fuel 5414830 (QTY 1) Seal
Parts Availability	Available to order
University of Polaris Video Training Required	Yes ¹

¹Polaris requires one person from a dealership to be certified before parts ordering may occur and two people from a dealership to be certified before warranty claims may be processed.

Claim Submission:

- **US / Canada Dealers:** On DEX, go to Service and Warranty > Warranty Claim and Extended Coverage > Start a New Warranty Claim. Select Service Bulletin> Enter the VIN / PIN and Retrieve Registration. Select I-22-06-B and Send Claim.
- **International Dealers:** On iDEX, go to Service and Warranty> Warranty Claims>Start a New Warranty Claim. Select Service Bulletin> Enter the VIN / PIN and Retrieve Registration. Select I-22-06-B and Send Claim

DECLINED SAFETY RECALL

Polaris provides a claim process that allows dealers to accurately document when a Safety Recall cannot be performed on a vehicle due to modification. Criteria and instructions can be found under Service & Warranty > STOP Site > News, Forms, & Links > Declined Safety Bulletin Tracking.

The information contained within this document is confidential and protected by U.S. and international copyright laws, and is the property of Polaris Inc. This document is provided for the sole use of authorized Polaris dealers and distributors. This document is not to be distributed, duplicated, or copied, digitally or otherwise, without the written consent of Polaris Inc.

INVENTORY / STOCK PART CLAIMS

Dealers should review their service parts inventory of the part numbers listed below, and inspect the date code on the part. The part is BAD and should **NOT** be used if the date code falls within **20210308– 20210910** (format YYYYMMDD):

GOOD	BAD	GOOD
XXXXXXXX - 20210307	20210308– 20210910	20210911 – XXXXXXXX

<ul style="list-style-type: none"> • 2521733 • 2522501 	
--	--

NOTICE

To remove these service parts from circulation, file a Part Stock claim as directed below.

Use the following process for filing a Part Stock warranty claim for any of the parts listed above.

1. Start a new Part Stock warranty claim.
2. Select Product Line: IND
3. Enter today's date into the Date Failed and Date Repair information fields
4. Enter Indian Motorcycle® I-22-06 into the CONCERN field.
5. Enter Indian Motorcycle® I-22-06 into the CAUSE field.
6. Enter Removed From Inventory into the CORRECTION field.
7. Enter the part number and quantity.
8. Enter warranty fail codes: 140/280/152
9. Validate the parts.
10. Save and submit the claim to Polaris.

COVERAGE PERIOD

Coverage will begin on November 17, 2022. This bulletin has no expiration date.

PARTS RETURN / DISPOSAL INFORMATION

Under no circumstances shall the parts removed be re-used, sold, or re-purposed for another application. It is your dealership / distributor's responsibility to make sure every part replaced (related to this communication) is taken out of circulation and disposed of properly or returned to Polaris (if required).

FEEDBACK FORM

A feedback form has been created for the technician to provide Polaris with an overall satisfaction rating for the instructions, provide comments on your experience or upload pictures/video. The form is viewable on mobile devices by scanning the QR code or on a PC by clicking [HERE](#).



I-22-06-A, 2022 CHIEF - FUEL PUMP REPLACEMENT

TOOLS REQUIRED

- Pliers, Side Cutting
- Socket Set, Metric
 - Socket Size 8, 10, 12 mm
- Sockets, Hex
 - Size. 4, 5, 6 mm
- Torque Wrench
- Fuel Siphon Tool
- Absorbent Mats

VEHICLE PREPARATION

1. Park motorcycle on a flat surface, fully extend side stand, and make sure vehicle is stable.
2. Turn key or ignition switch to OFF position and remove key. If equipped with keyless fob, remove fob from proximity of vehicle.
3. Remove the seat:

Rear Seat Removal (if equipped)

- a. Remove pillion seat fastener ①.

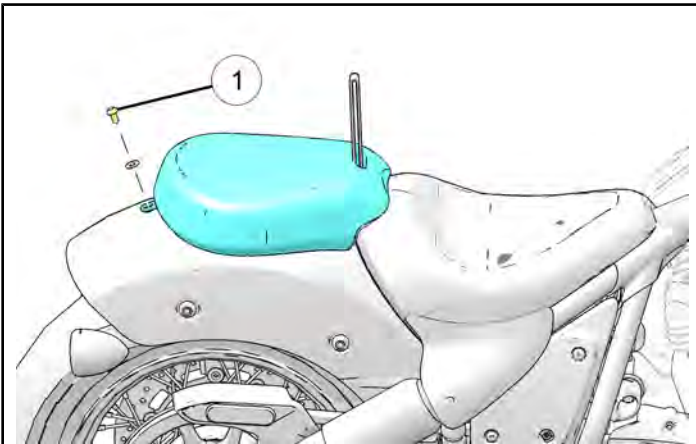

- b. Pull pillion seat upward off of seat stud to remove.

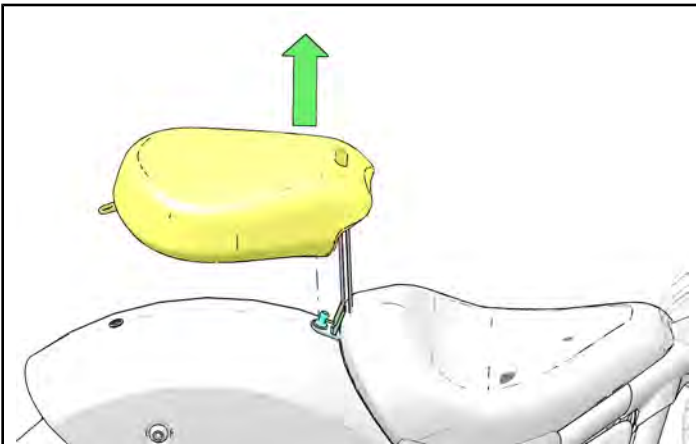

Front Seat Removal

- a. Remove pillion seat stud ②.

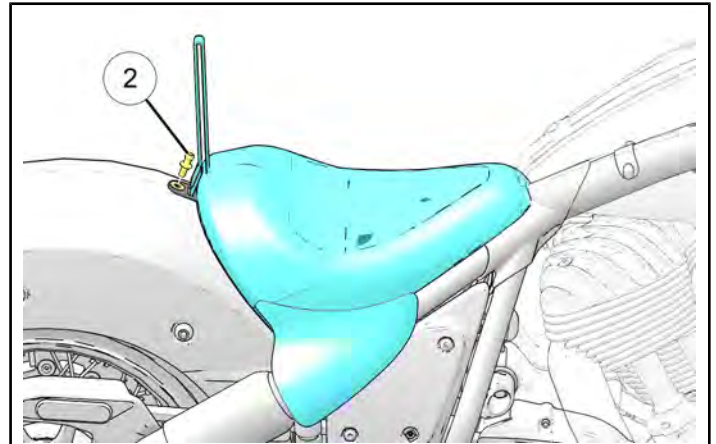

- b. Lift the rear of the seat upward and slide back to remove.

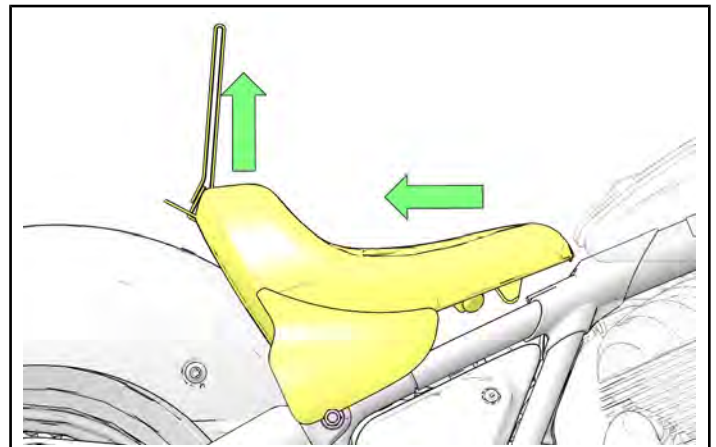

FUEL SYSTEM DEPRESSURIZATION

⚠ WARNING

Allow engine and exhaust to cool completely before disconnecting fuel line or removing tank. Wear eye protection.

1. Locate the fuse box ① and remove its cover.

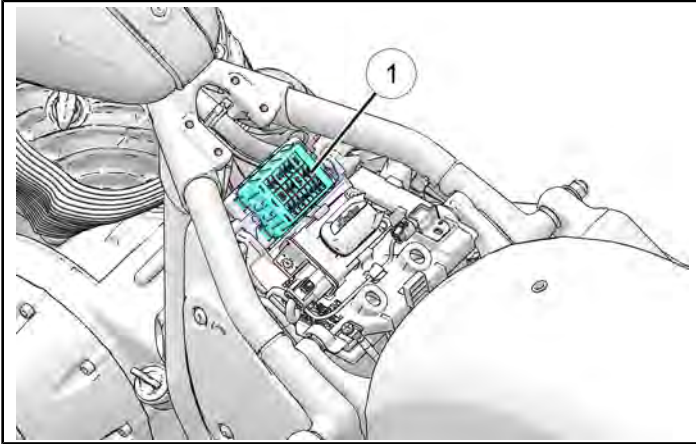

2. Locate the fuel pump relay. Pull the fuel pump relay and crank the engine over for 5 seconds to release fuel pressure.

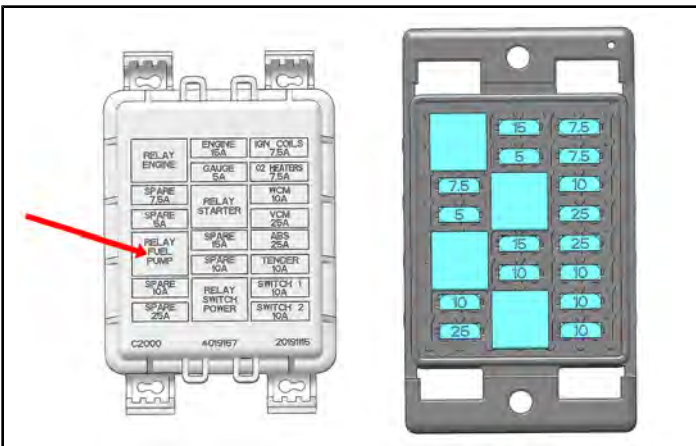

3. With the motorcycle powered off, install the fuel pump relay. Install the fuse box cover.

4. Remove ignition cover by removing its fasteners ①.

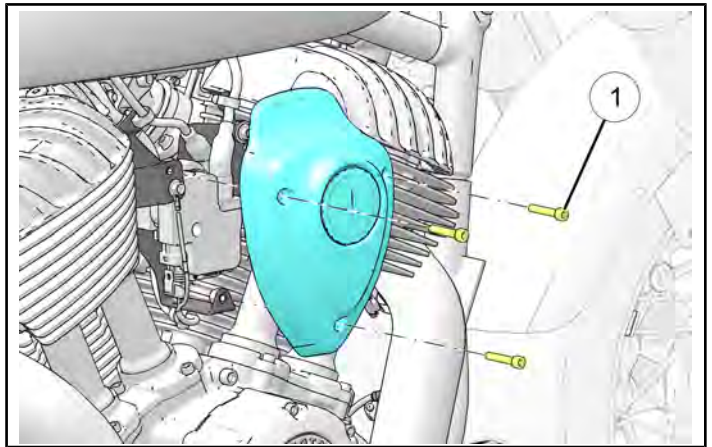

5. Wrap a clean shop rag around fuel line fitting ②.
6. Squeeze both release buttons (one on each side of fitting) and hold. Gently slide fitting straight off fuel rail.

STOP!

Do not use anything other than fingers to remove the quick connection. The use of tools can damage the connection.

IMPORTANT

Use a shop rag to catch any residual fuel in the system.

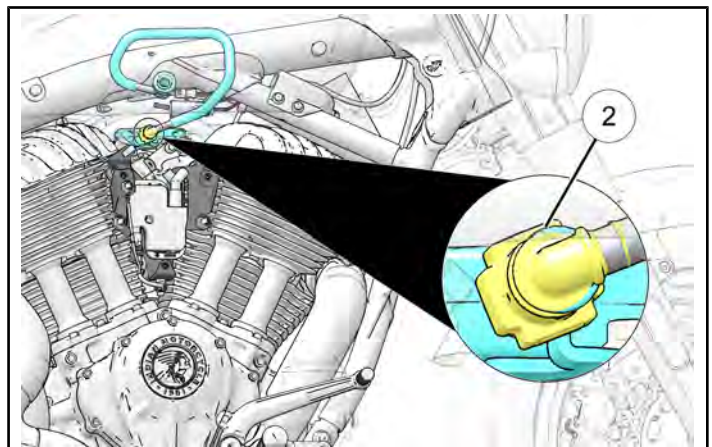

7. Cover fuel fittings to keep debris out.

DRAIN FUEL SYSTEM

1. Drain fuel from tank using a clean vacuum or siphon pump designed for fuel systems.
2. Retain drained fuel in a clean container safe for fuel and reuse later.

FUEL TANK REMOVAL

1. Remove fuel tank console by removing its fasteners ① and set aside.

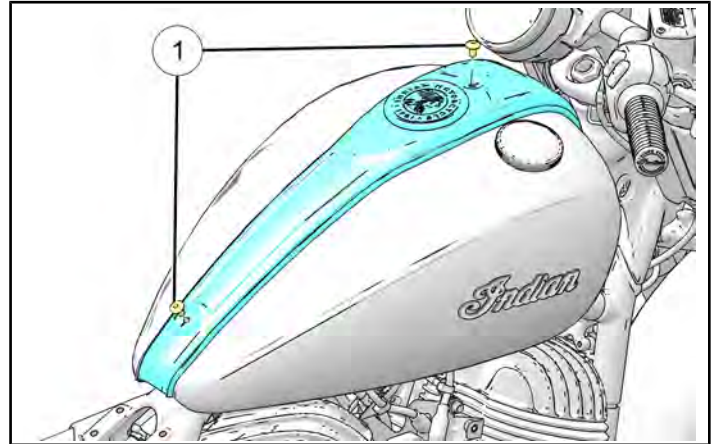

NOTICE

Do not disconnect any electrical connectors. The wires are long enough to allow the console to be set aside while staying connected.

2. Remove fuel tank bracket fasteners ②.

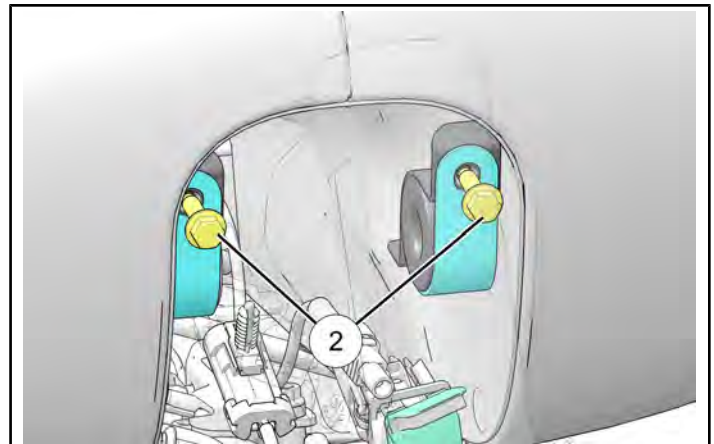

3. Rotate the fuel tank brackets downward to disconnect the mount from the isolator.

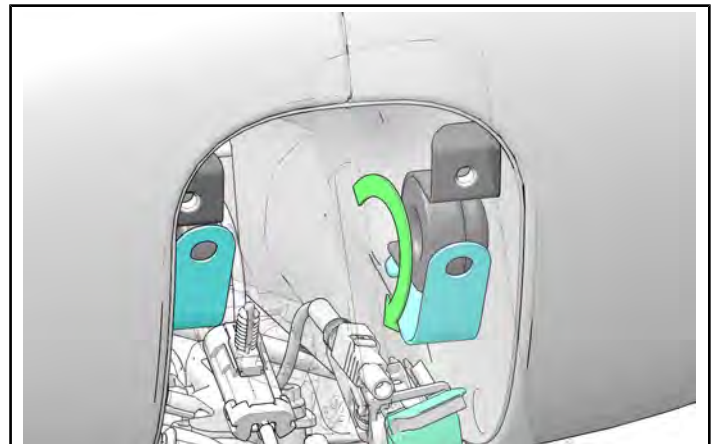

4. Slowly pull the fuel tank up and disconnect the fuel pump electrical connector ③ and fuel vent line ④.

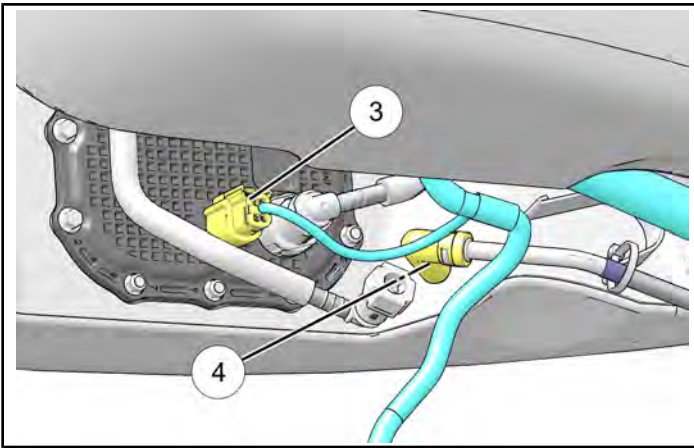

STOP!

Do not use anything other than fingers to remove the electrical connection. The use of tools can damage the connection.

5. Lifting at the front and rear of the tank at the same time, slide the tank upward and rearward to remove from unit.

IMPORTANT

Carry the fuel tank flat to avoid any fuel spills.

6. Set the fuel tank on absorbent mats to avoid damage to the tank.

IMPORTANT

Cover the vent line with a clean rag to prevent a fuel spill.

FUEL PUMP REMOVAL

CAUTION

Be careful when performing this procedure to avoid damaging the fuel pump, electrical wiring, fuel level sender, or hoses. Always inspect wires and hoses closely for damage after removing the fuel pump.

1. Tilt the fuel tank and siphon out any remaining fuel, if necessary.
2. Remove fuel line retainer push pin ③ and save.

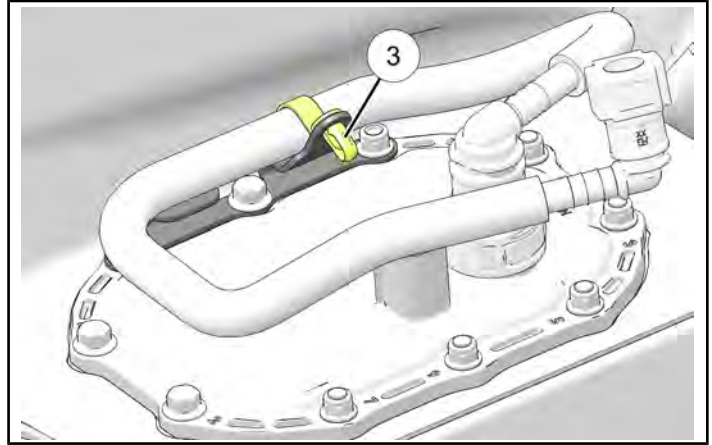

3. Disconnect fuel line ② from the fuel pump.

STOP!

Do not use anything other than fingers to remove the quick connection. The use of tools can damage the connection.

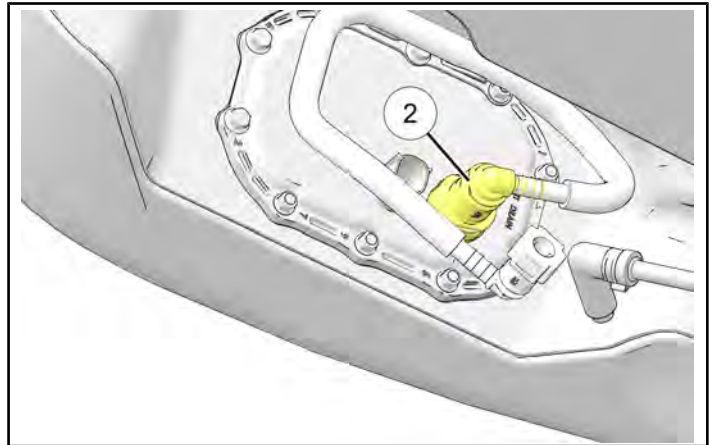

4. Remove fuel pump fasteners ①.

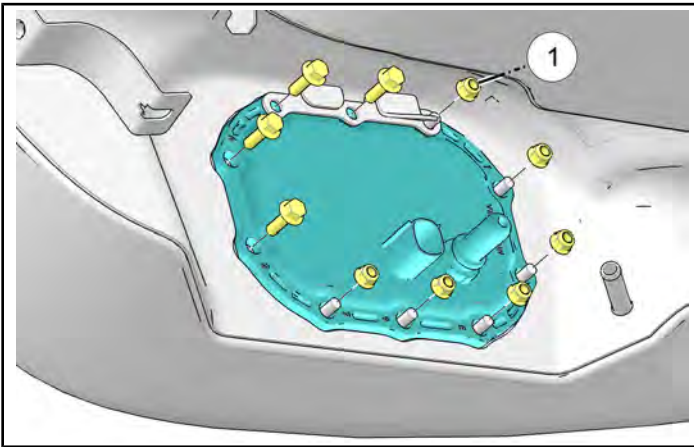

NOTICE

Working with the fuel tank upside down may be helpful. Make sure the gas cap is installed and place the tank on a soft surface to remove the fuel pump fasteners.

5. Starting at the rear, lift the fuel pump assembly and carefully remove from fuel tank.

6. Remove cable tie and remove the pickup baffle ④ and save for installation.

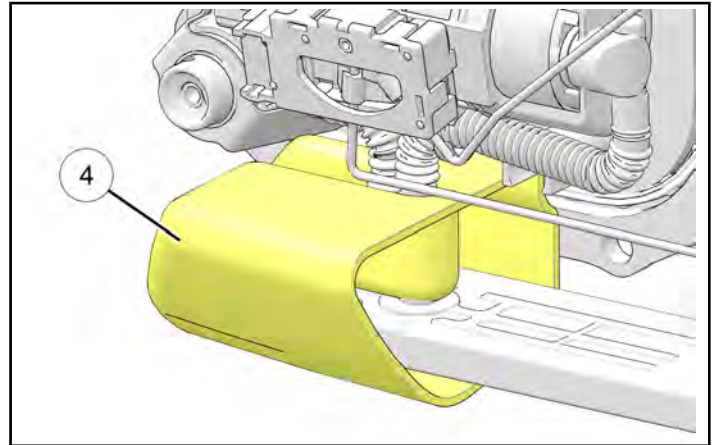

STOP!

Remove the fuel pump seal, CUT and DISCARD along with fuel pump.

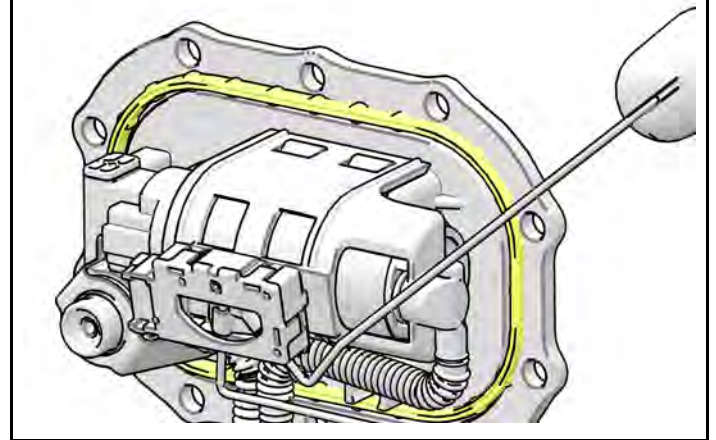

FUEL PUMP INSTALLATION

1. Install pickup baffle to NEW pump. Secure with cable tie supplied in the kit.

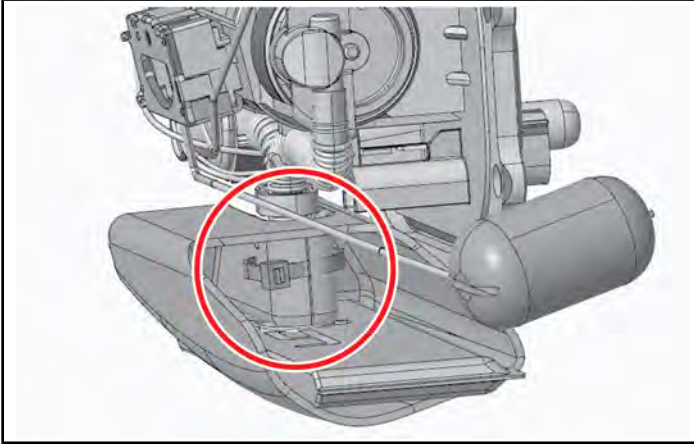

⚠ WARNING

Do NOT use alternative cable tie. ONLY use the 7080138 cable tie supplied. Failure to use proper cable tie may result in the cable tie dissolving in the fuel.

2. Install NEW fuel pump seal.

⚠ WARNING

Ensure a NEW seal is used. Failure to use a new seal may result in a fuel leak.

3. Install the fuel pump assembly into the bottom of the fuel tank:
 - a. Insert fuel filter and level sender arm first before guiding the rest of the fuel pump into the fuel tank.
 - b. Verify the filter is positioned correctly in the fuel tank before installing fasteners.

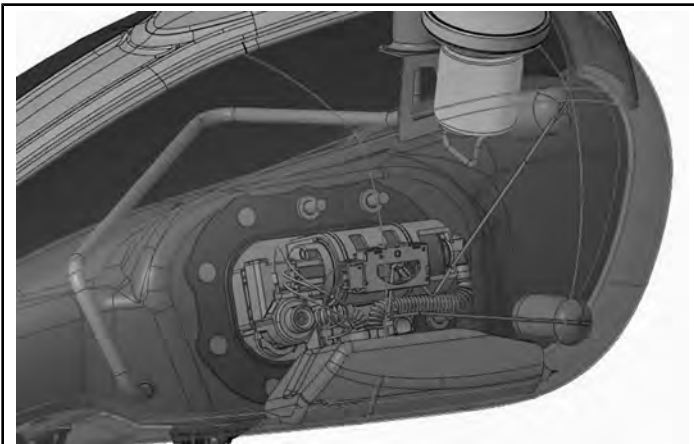

- c. Once installed, ensure the pump moves freely. Verify by slightly moving the pump in each direction to make sure it does not feel "bound" on the fuel tank.

IMPORTANT

Ensure the fuel sender arm and assembly is not damaged upon installation.

4. Install fuel pump fasteners ① and tighten to specification following the torque sequence shown.

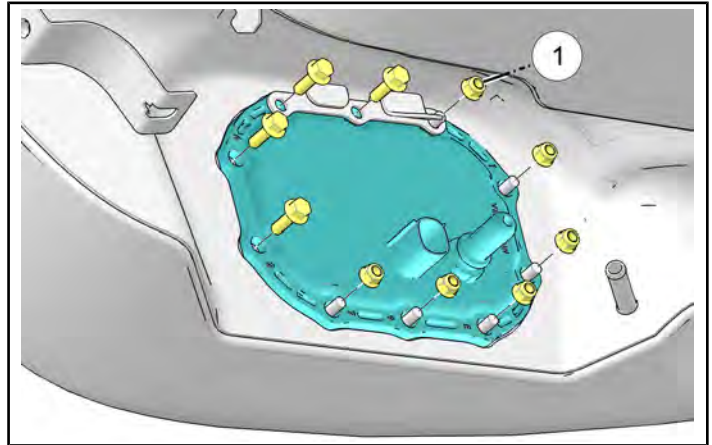

NOTICE

Make sure the fuel line routing retention bracket has the proper orientation as shown.

NOTICE

Working with the fuel tank upside down may be helpful. Make sure the gas cap is installed and place the tank on a soft surface to install the fuel pump fasteners.

NOTICE

Make sure the fuel pump seal is not rolled or missing

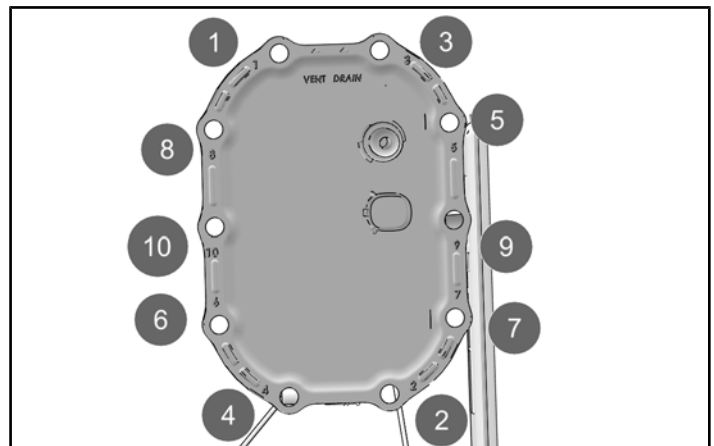

TORQUE

Fuel Pump Fastener / Nut:
44 in-lbs (5 N·m)

5. Attach the push pin retaining strap ③ to the fuel line.

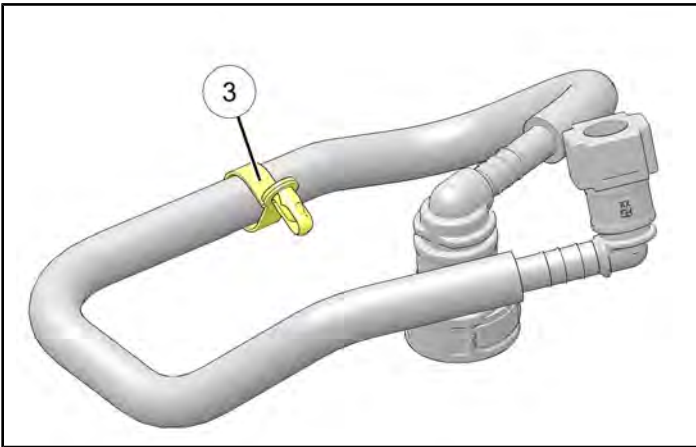

6. Install the fuel line push pin retaining strap ③ onto the pump bracket as shown.

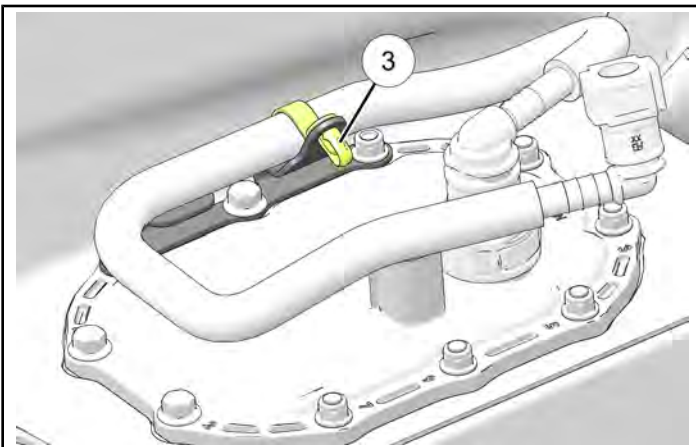

7. Connect fuel line ② to the fuel pump.

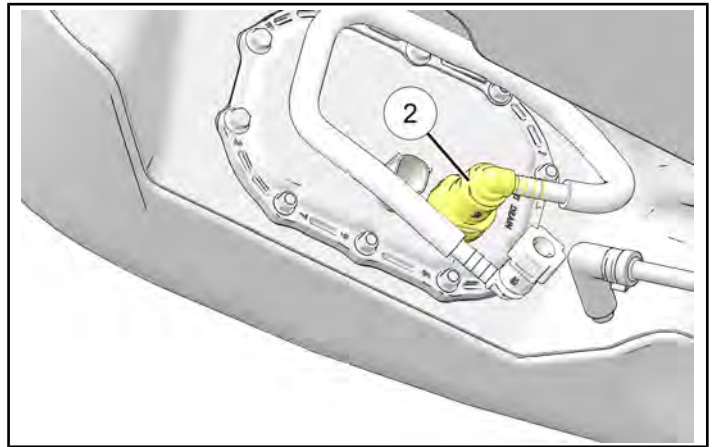

STOP!

Verify fuel line is properly seated and locked in place by listening for an audible “click” when pressing into place. Pull gently on quick connector to make sure a proper connection has been made.

A second technician must verify the following:

- Fuel line is properly routed, seated onto the fuel pump, and locked in place.
- Fuel line connector is fully engaged.
- Fuel lines connections stay secured when performing push/pull test with at least 5 lbs. of force.

IF THE FUEL LINE FAILS TO CLICK, OR FAILS THE PULL PORTION OF THE TEST ABOVE, REPLACE THE FUEL LINE.

FUEL TANK INSTALLATION

NOTICE

Make sure the fuel tank is clean before installation.

1. Apply a soapy water solution to the isolators and carefully lower the fuel tank onto the frame.
2. Engage the rear isolators first and then rotate the tank downward onto the front isolators.
3. Connect fuel tank vent line ④ and fuel pump electrical connector ③.

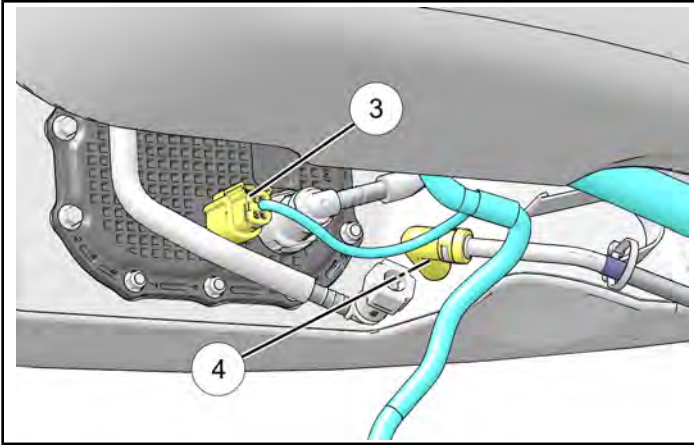

WARNING

Verify electrical connector is properly seated and locked in place by listening for an audible “click” when pressing into place. Pull gently on electrical connector to make sure a proper connection has been made.

4. Continue lowering the fuel tank until it is fully seated on the isolators.
5. Install fuel tank bracket fasteners ②.

TORQUE

Fuel Tank Mount Fastener:
88 in-lbs (10 N·m)

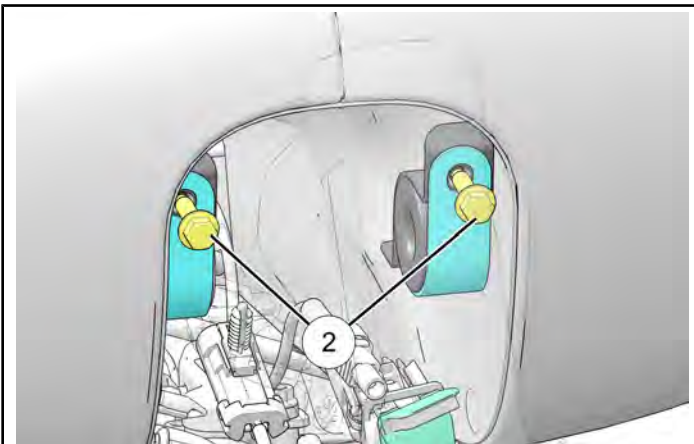

6. Connect the fuel line to the fuel rail.

STOP!

Verify fuel line is properly seated and locked in place by listening for an audible “click” when pressing into place. Pull gently on quick connector to make sure a proper connection has been made.

A second technician must verify the following:

- Fuel line is properly routed, seated onto the fuel pump, and locked in place.
- Fuel line connector is fully engaged.
- Fuel lines connections stay secured when performing push/pull test with at least 5 lbs. of force.

IF THE FUEL LINE FAILS TO CLICK, OR FAILS THE PULL PORTION OF THE TEST ABOVE, REPLACE THE FUEL LINE.

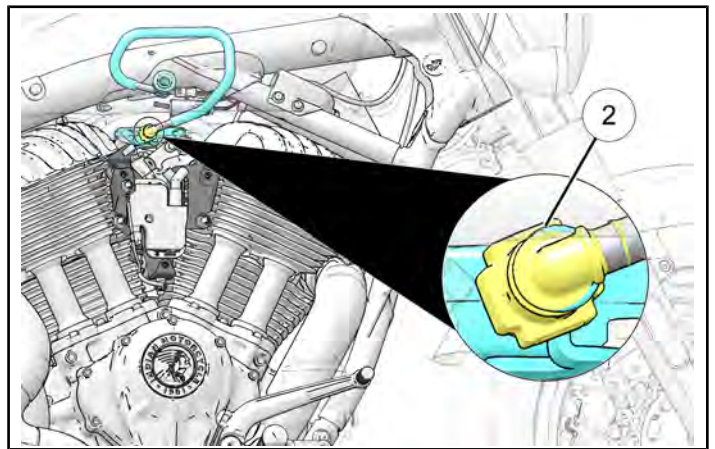

7. Install fuel tank console and secure it with fasteners ①. Torque fasteners to specification.

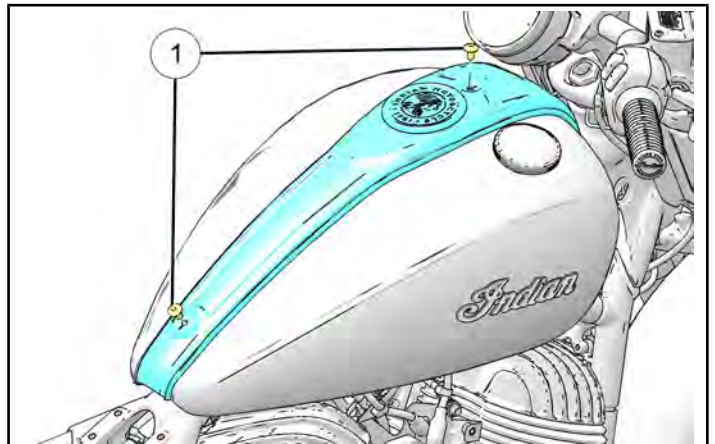

TORQUE

Fuel Tank Console Fastener:
88 in-lbs (10 N·m)

8. Install the seat:

- a. Position the seat by inserting the seat mounting tabs from rear to front into the frame.
- b. Rotate the rear of the seat downward and position the rear mount seat bracket onto the fender.
- c. Thread the seat mount bolt through the seat mount bracket and into the fender. Torque the seat bolt ② to specification.

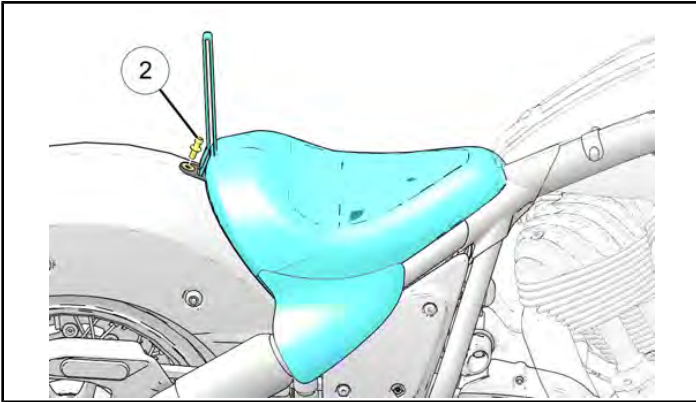

TORQUE

Pillion Seat Stud (Bagger):
13 ft-lbs (18 N·m)

Rear Seat Installation (if equipped)

- a. Position the passenger seat near the fender, and push the grab strap through the seat bottom.
- b. Lower the passenger seat onto the seat post, and push downward to engage the seat grommet to the seat post.
- c. Gently raise the rear bracket and reinstall the nylon grommet.
- d. Thread the rear bracket bolt and washer through the bracket and nylon grommet. Torque the bolt ① to specification.

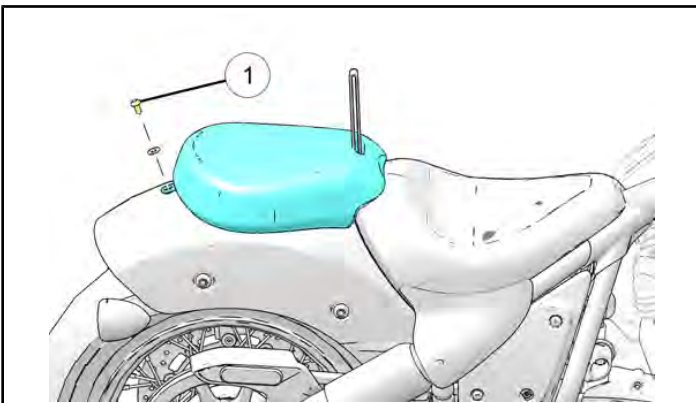

TORQUE

Pillion Seat Fastener (Bagger):
13 ft-lbs (18 N·m)

PRIME THE FUEL SYSTEM

1. Power on the motorcycle, **DO NOT START**, verify the low fuel light comes on, this may take up to 5 minutes.
2. Fill the fuel tank.

IMPORTANT

Make sure the fuel tank is full.

3. Turn Engine Stop switch OFF.
4. Turn the ignition switch to ON.
5. Turn stop switch to RUN.
6. Allow switch to remain in RUN position until pump stops running (about 2-3 seconds).

NOTICE

You should hear the fuel pump running to cycle fuel. If you don't, check the electrical connection to the fuel pump.

7. Turn stop switch OFF.
8. Turn the ignition switch to OFF.
9. *WAIT* approximately 10 seconds.
10. Repeat Steps 4-8 four times to complete the priming procedure.

STOP!

- a. Start the motorcycle.
- b. Verify no fuel leaks are present around the fuel line connectors or fuel pump seal area.
- c. Verify proper fuel level function.

11. Install ignition cover and secure with its fasteners ①. Torque fasteners to specification.

TORQUE

Ignition Cover Fasteners:
88 in-lbs (10 N·m)

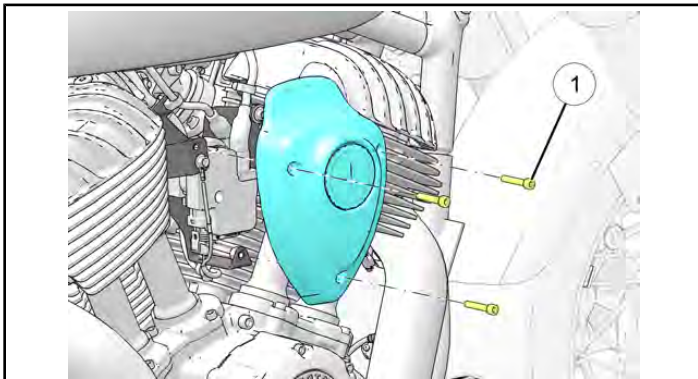

12. Submit a Service Bulletin Warranty Claim for I-22-06-A.

The information contained within this document is confidential and protected by U.S. and international copyright laws, and is the property of Polaris Inc. This document is provided for the sole use of authorized Polaris dealers and distributors. This document is not to be distributed, duplicated, or copied, digitally or otherwise, without the written consent of Polaris Inc.

I-22-06-B, 2021-2022 SCOUT - FUEL PUMP REPLACEMENT

TOOLS REQUIRED

- Pliers, Side Cutting
- Socket Set, Metric
 - Socket Size 8, 10, 12 mm
- Sockets, Hex
 - Size. 4, 5, 6 mm
- Torque Wrench
- Fuel Siphon Tool
- Absorbent Mats

VEHICLE PREPARATION

1. Park motorcycle on a flat surface, fully extend side stand, and make sure vehicle is stable.
2. Turn key to OFF position and remove key.
3. Remove the seat:
 - a. Lift up on the seat front to disengage the front of the seat from the frame post.

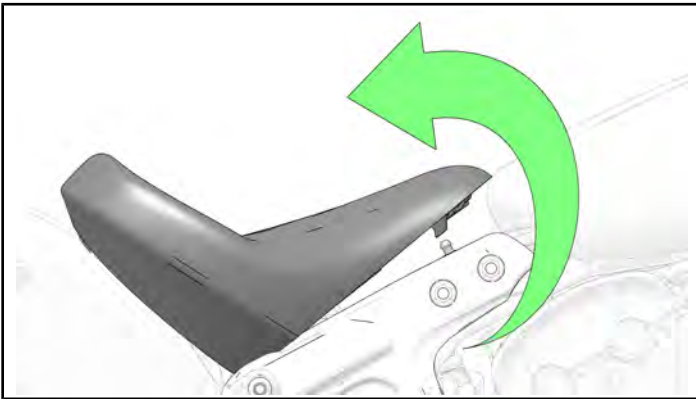

- b. Lift the seat and pull rearward to disengage the seat from the mount holding the back of the seat to the frame.

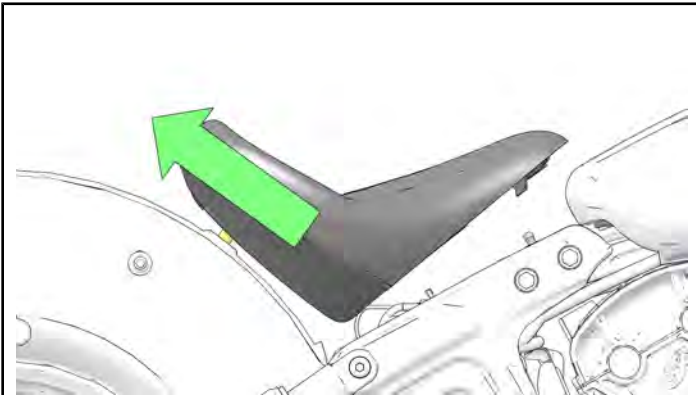

FUEL SYSTEM DEPRESSURIZATION

WARNING

Allow engine and exhaust to cool completely before disconnecting fuel line or removing tank. Wear eye protection.

1. Locate the fuse box, under the seat. Press inward on the fuse box cover latches and remove cover.

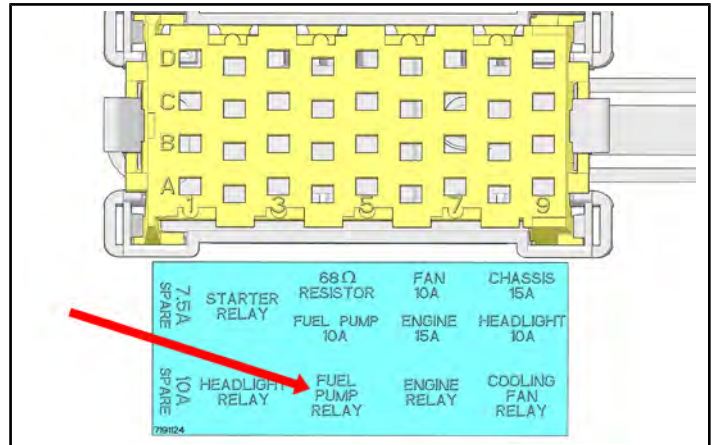

2. Pull the fuel pump relay and crank the engine over for 5 seconds to release fuel pressure.
3. With the motorcycle powered off, install the fuel pump relay. Install the fuse box cover.

DRAIN FUEL SYSTEM

1. Drain fuel from tank using a clean vacuum or siphon pump designed for fuel systems.
2. Retain drained fuel in a clean container safe for fuel and reuse later.

FUEL TANK REMOVAL

1. Remove thermostat cover by removing its fasteners ④.

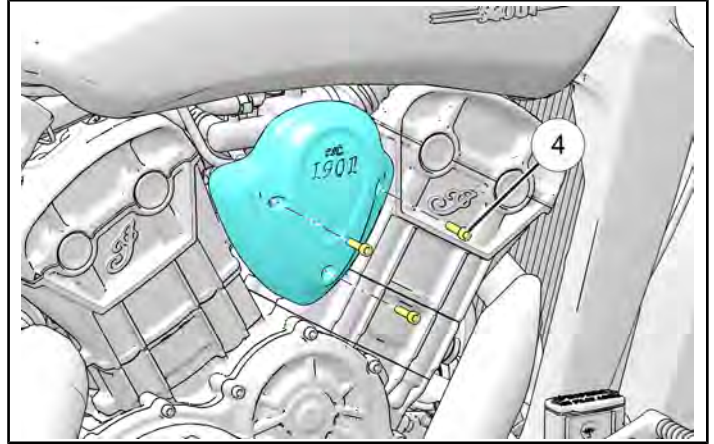

2. Squeeze both release buttons (one on each side of fitting) and hold. Gently slide fitting ⑤ straight off fuel rail. This allows for extra slack when removing fuel tank.

STOP!

Do not use anything other than fingers to remove the quick connection. The use of tools can damage the connection.

IMPORTANT

Use a shop rag to catch any residual fuel in the system.

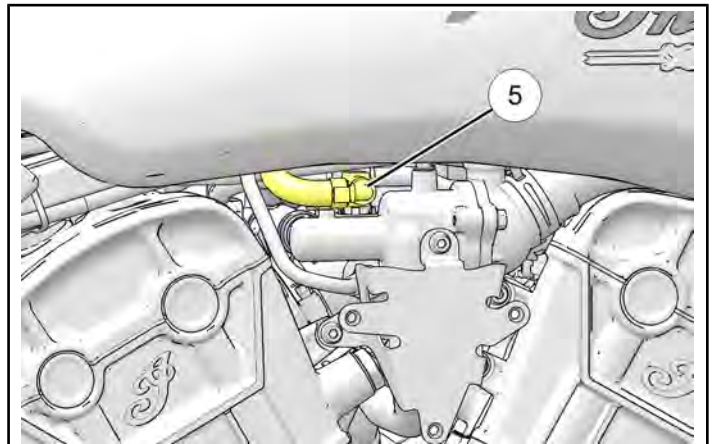

3. Remove the fuel tank filler pad ①.

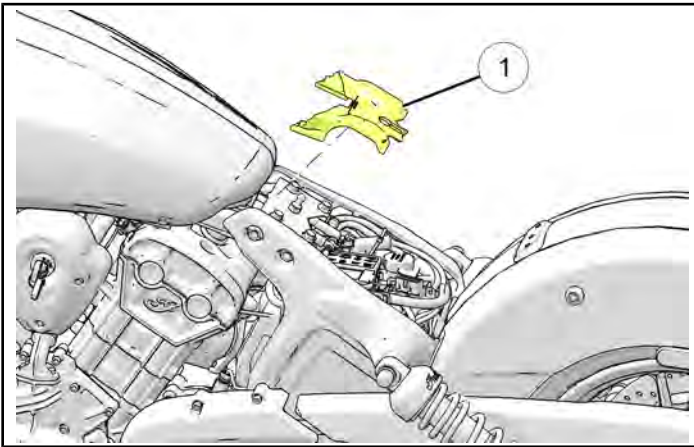

4. Disconnect vent and drain lines ③. Remove the four bolts ② at the rear of the fuel tank.

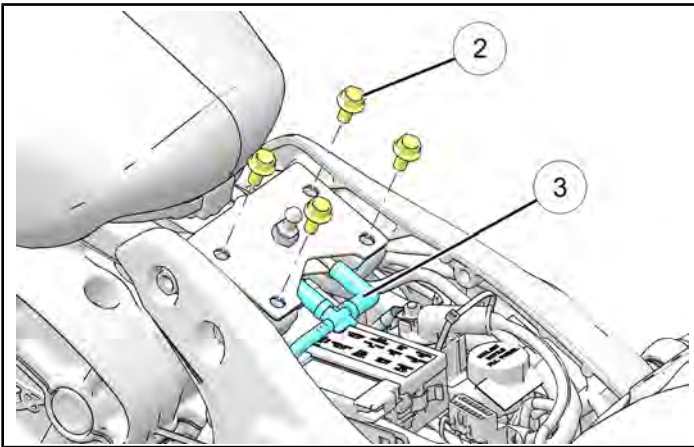

5. Slightly lift the fuel tank to disconnect fuel line ⑤ and fuel pump electrical connector ⑥.

STOP!
Do not use anything other than fingers to remove the quick connection and electrical connector. The use of tools can damage the connection.

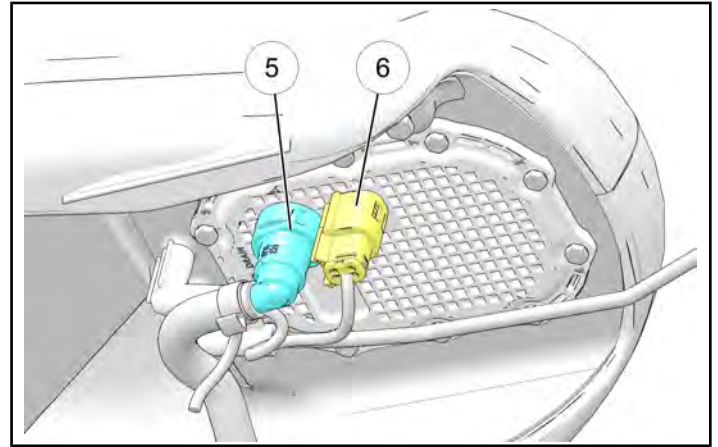

IMPORTANT
Do not remove the fuel line from the chassis.

6. Lift the rear of the fuel tank and slide rearward to release from the front isolators.

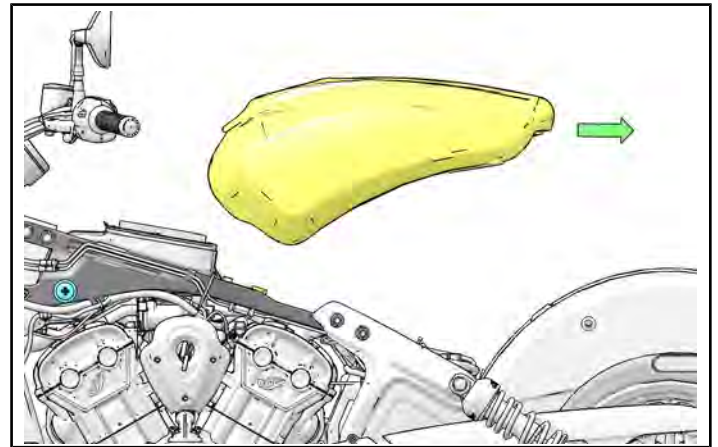

7. Lift the fuel tank off the motorcycle and place on a suitable flat surface to prevent tank damage.

IMPORTANT
Carry the fuel tank flat to avoid any fuel spills.

FUEL PUMP REMOVAL

⚠ CAUTION

Be careful when performing this procedure to avoid damaging the fuel pump, electrical wiring, or hoses. Always inspect wires and hoses closely for damage after removing the fuel pump.

1. Remove tank mount assembly by removing four bolts ②.

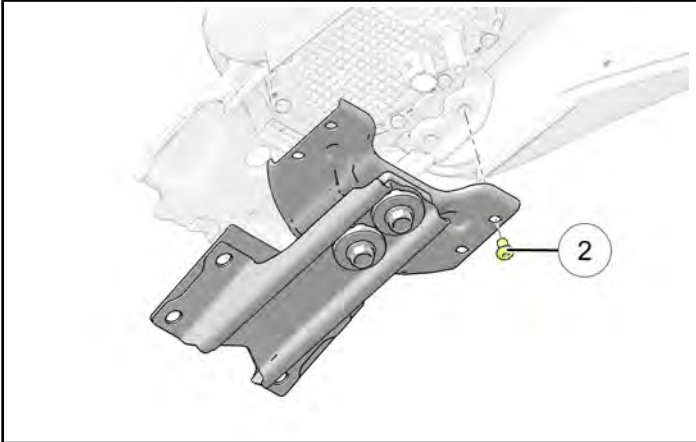

2. Disconnect fuel vent/drain hoses ①.

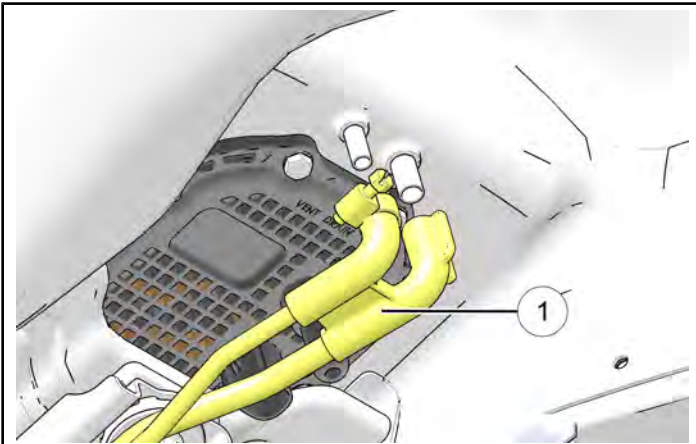

3. Remove fuel pump bolts ③.

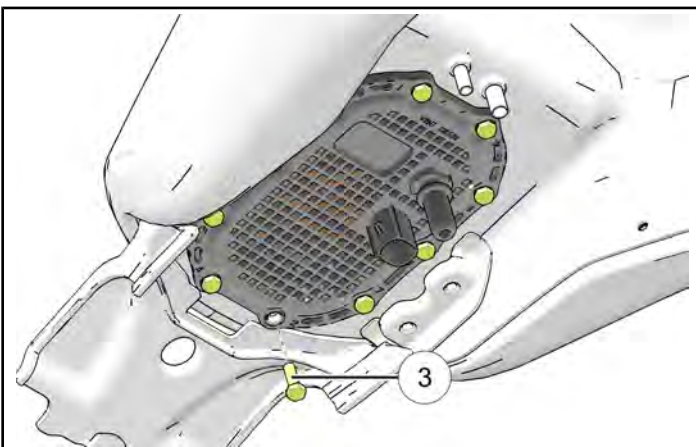

4. Lift the fuel pump assembly and carefully remove from fuel tank.

STOP!

Remove the fuel pump seal, CUT and DISCARD along with fuel pump.

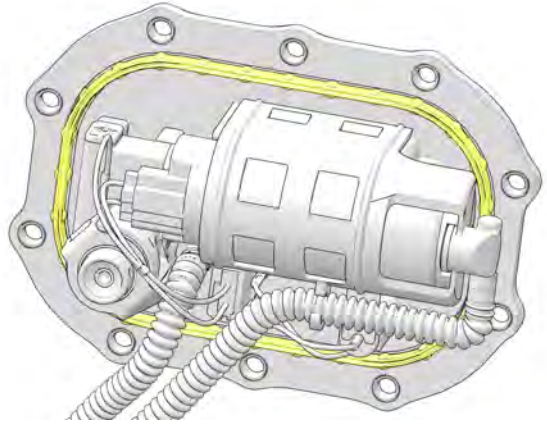

FUEL PUMP INSTALLATION

1. Install NEW fuel pump seal onto the NEW pump.

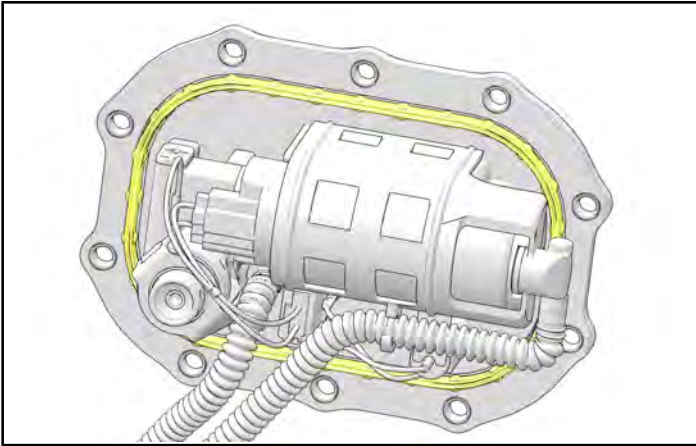

⚠ WARNING

Ensure a NEW seal is used. Failure to use a new seal may result in a fuel leak.

2. Install fuel pump assembly into bottom of gas tank:
 - a. Insert fuel filter ④ first before guiding the rest of the fuel pump into fuel tank.

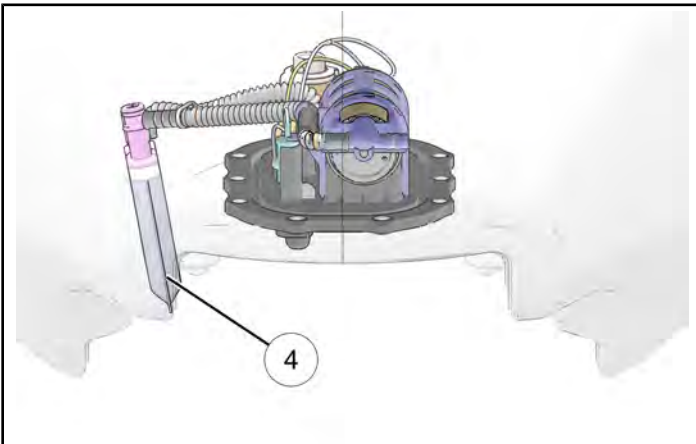

- b. Verify the filter is positioned correctly in the fuel tank before installing fasteners.
- c. Once installed, ensure the pump moves freely. Verify by slightly moving the pump in each direction to make sure it does not feel “bound” on the fuel tank.

3. Install fuel pump fasteners ③ and tighten to specification following the torque sequence shown.

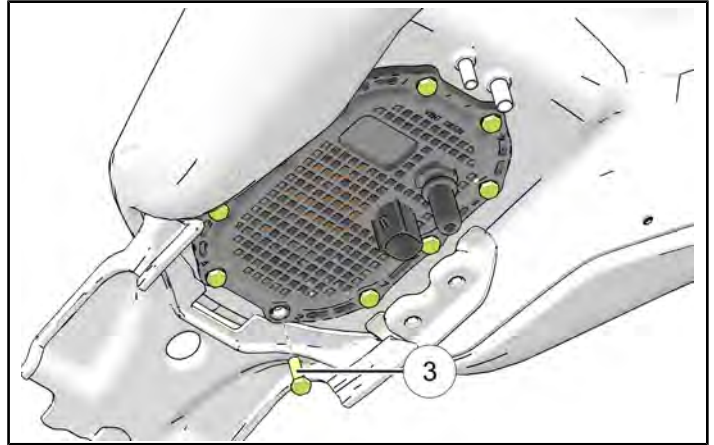

NOTICE

Make sure the fuel pump seal is not rolled or missing

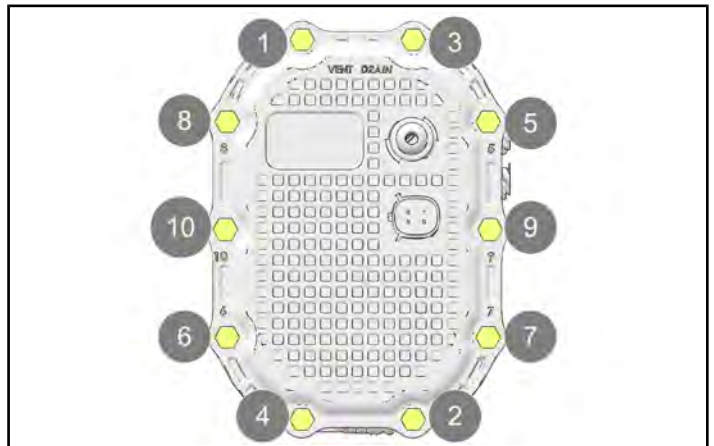

TORQUE

Fuel Pump Fasteners:
44 in-lbs (5 N·m)

4. Connect fuel vent/drain hoses ①.

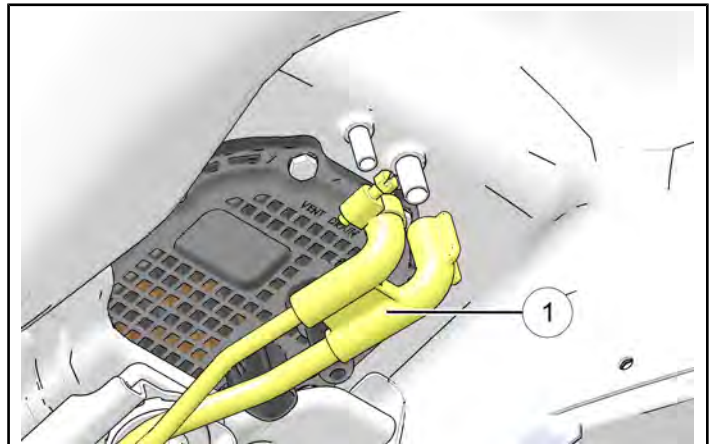

5. Install tank mount assembly using four bolts ②.
Torque to specification.

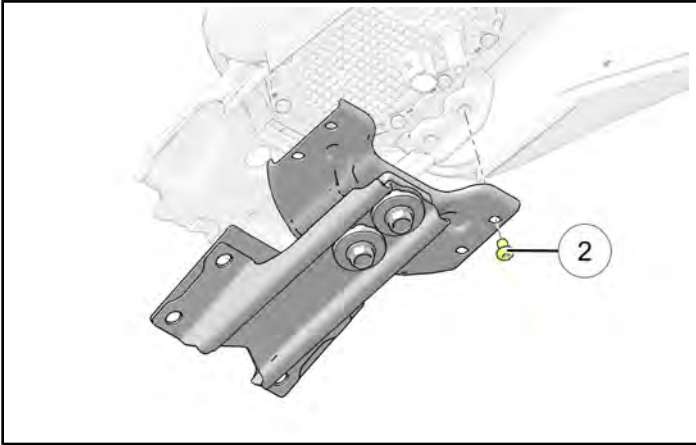

TORQUE

Fuel Tank Mount Assembly Fasteners:
88 in-lbs (10 N·m)

FUEL TANK INSTALLATION

NOTICE

Make sure the fuel tank is clean before installation.

1. Secure the handlebars in the straight ahead position.
2. Apply a soapy water solution to the isolators and carefully lower the fuel tank onto the tank isolators.
- 3.

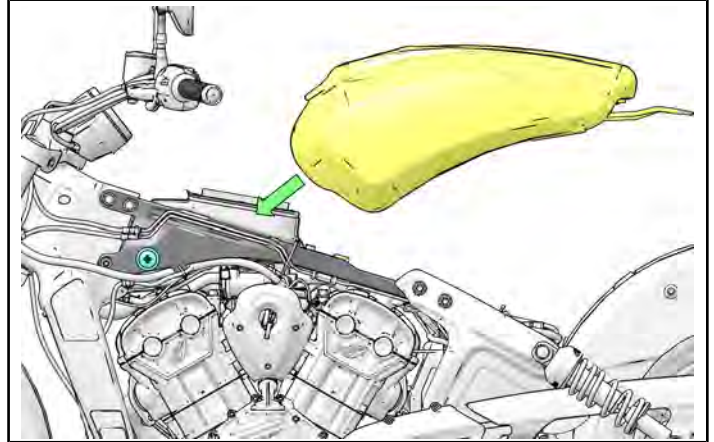

4. While supporting rear of fuel tank, connect fuel line to pump ⑤. Connect fuel pump electrical connector ⑥.

STOP!

Verify fuel line is properly seated and locked in place by listening for an audible “click” when pressing into place. Pull gently on quick connector to make sure a proper connection has been made.

A second technician must verify the following:

- Fuel line is properly routed, seated onto the fuel pump, and locked in place.
- Fuel line connector is fully engaged.
- Fuel lines connections stay secured when performing push/pull test with at least 5 lbs. of force.

IF THE FUEL LINE FAILS TO CLICK, OR FAILS THE PULL PORTION OF THE TEST ABOVE, REPLACE THE FUEL LINE.

⚠ WARNING

Verify electrical connector is properly seated and locked in place by listening for an audible “click” when pressing into place. Pull gently on electrical connector to make sure a proper connection has been made.

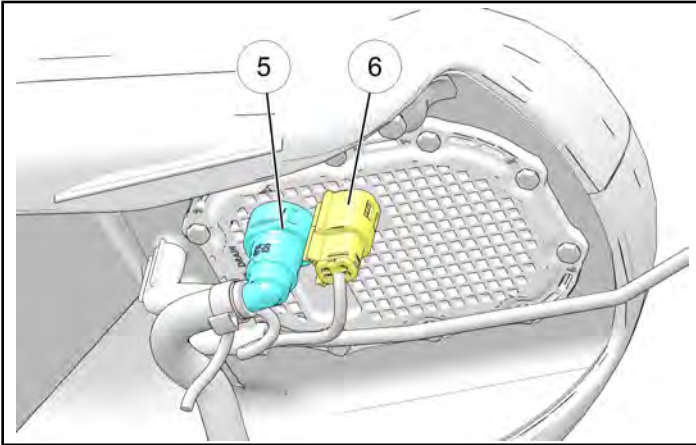

5. Install fuel tank mounting fasteners ②.

TORQUE

Fuel Tank Mounting Fasteners:
18 ft-lbs (24 N·m)

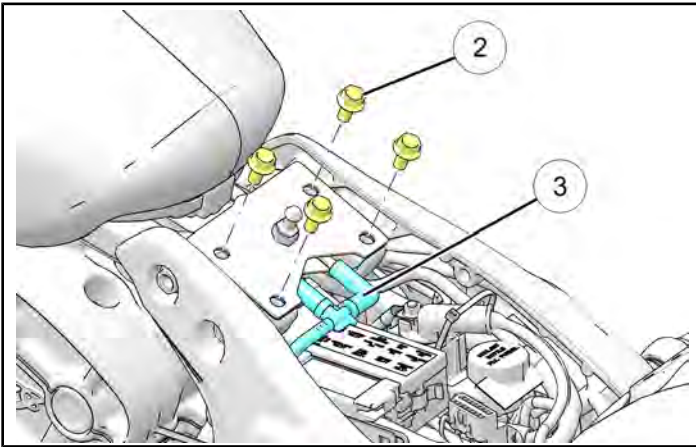

6. Connect the fuel tank vent line and the fuel cap recess drain line ③.

7. Install the fuel tank filler pad.

8. Connect the fuel line ⑤ to the fuel rail.

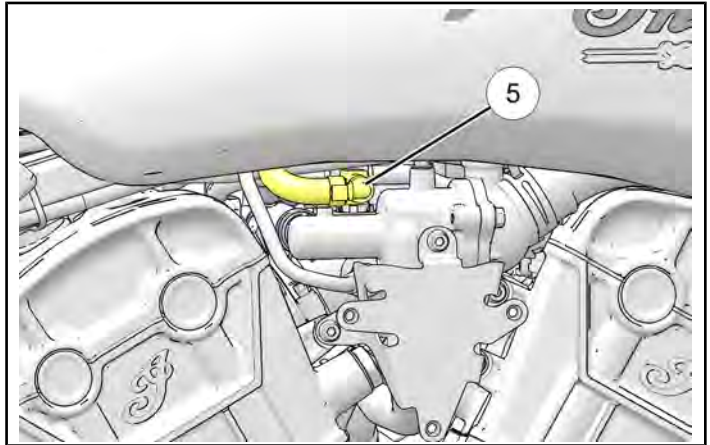

STOP!

Verify fuel line is properly seated and locked in place by listening for an audible “click” when pressing into place. Pull gently on quick connector to make sure a proper connection has been made.

A second technician must verify the following:

- Fuel line is properly routed, seated onto the fuel pump, and locked in place.
- Fuel line connector is fully engaged.
- Fuel lines connections stay secured when performing push/pull test with at least 5 lbs. of force.

IF THE FUEL LINE FAILS TO CLICK, OR FAILS THE PULL PORTION OF THE TEST ABOVE, REPLACE THE FUEL LINE.

9. Install the seat:

- a. Press the rear of the seat downward to engage the seat back to the frame post ⑦.

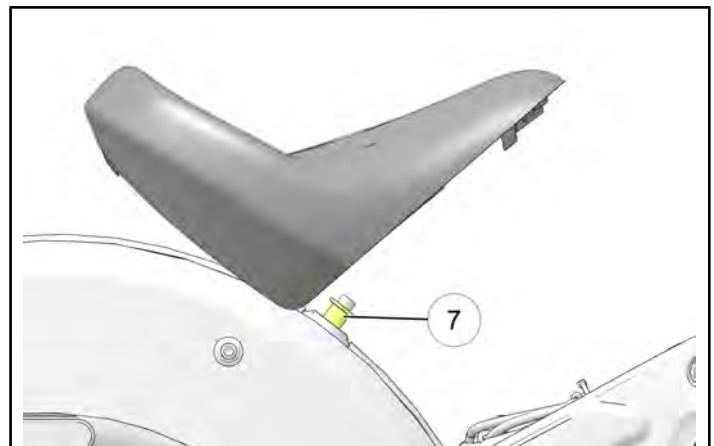

- b. Push down on the front of the seat to engage the front of the seat to the frame post.

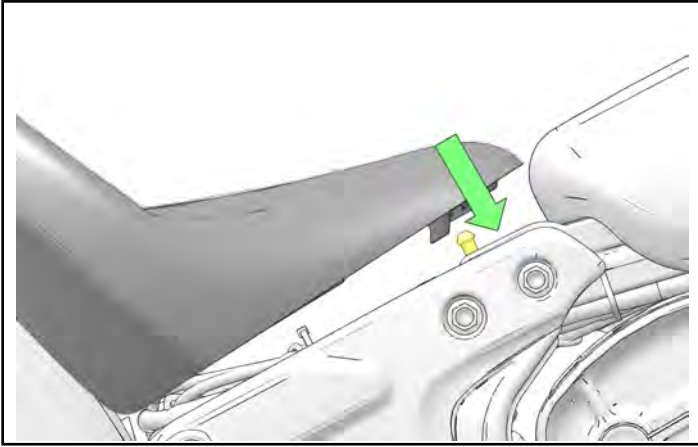

PRIME THE FUEL SYSTEM

1. Power on the motorcycle, **DO NOT START**, verify the low fuel light comes on, this may take up to 5 minutes.
2. Fill the fuel tank.

IMPORTANT

Make sure the fuel tank is full.

3. Turn Engine Stop switch OFF.
4. Turn the ignition switch to ON.
5. Turn stop switch to RUN.
6. Allow switch to remain in RUN position until pump stops running (about 2-3 seconds).

NOTICE

You should hear the fuel pump running to cycle fuel. If you don't, check the electrical connection to the fuel pump.

7. Turn stop switch OFF.
8. Turn the ignition switch to OFF.
9. *WAIT* approximately 10 seconds.
10. Repeat Steps 4-8 four times to complete the priming procedure.

STOP!

- a. Start the motorcycle.
- b. Verify no fuel leaks are present around the fuel line connectors or fuel pump seal area.
- c. Verify proper fuel level function.

11. Install thermostat cover and secure fasteners ④.
Torque fasteners to specification.

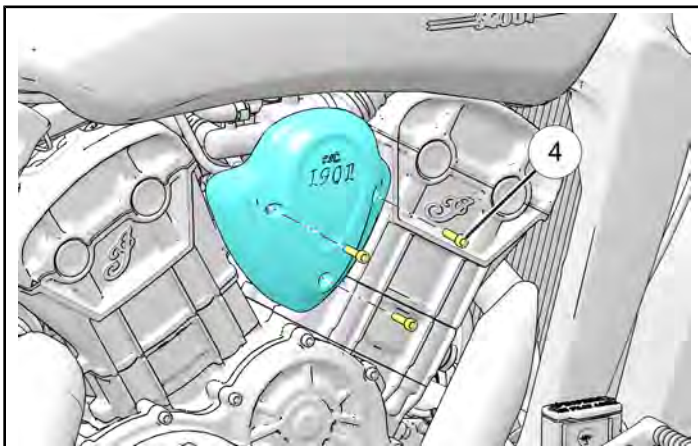

TORQUE

Thermostat Cover Fasteners:
96 in-lbs (11 N·m)

12. Submit a Service Bulletin Warranty Claim for I-22-06-B.