



**November 23, 2022**

Acting Administrator, Ann Carlson  
National Highway Traffic Safety Administration,  
1200 New Jersey Ave., SE  
Washington, DC 20590;

**RE: 22V819, Petition for Inconsequential Non-compliance, MVSS 108, 6.4.3 Turn Signal Visibility**

Dear Ms. Carlson

On behalf of Mack Trucks LLC, I respectfully submit this petition for your consideration. I appreciate yours and NHTSA's consideration of this matter.

A copy of this document has been uploaded to the recall portal under 22V819.

Best regards,

Emily Bishop

Director, Vehicle Certification & Compliance  
Complete Vehicle, USA  
emily.bishop@volvo.com  
+1 301 5735972  
7900 National Service Rd | Greensboro, NC, 27409 | USA | Volvo Group



**Information Required per 49CFR556**

**Full Name of Applicants:**

Mack Trucks LLC.  
7825 National Service Road,  
Greensboro, NC 27409-9416

**Nature of Business:** Vehicle Manufacture, Corporation

**State:** North Carolina

**Description of motor vehicles or items of motor vehicle equipment involved:**

- Brand: Mack
- Models: Certain 2015-2023 GU/GR Class 8 trucks and truck-tractors
- Manufacturing Dates: September 1, 2014-September 30, 2022 with different axle position and frame extension configurations.
- Total number of vehicles involved: 27544

**Description of non-compliance:**

This issue is relative to the MVSS 108, 6.4.3 turn signal visibility. Based upon different axle positions and frame extension configurations, the forward turn signals **on specific vehicles** are not compliant with the 45 degree inboard and/or 15 degree downward angle relative to the September 2014 regulation update.

S6.4.3 *Visibility options.* A manufacturer must certify compliance of each lamp function to one of the following visibility requirement options, and it may not thereafter choose a different option for that vehicle:(a) *Lens area option.* When a vehicle is equipped with any lamp listed in Table V-b each such lamp must provide not less than 1250 sq mm of unobstructed effective projected luminous lens area in any direction throughout the pattern defined by the corner points specified in Table V-b for each such lamp; or(b) *Luminous intensity option.* When a vehicle is equipped with any lamp listed in Table V-c each such lamp must provide a luminous intensity of not less than that specified in Table V-c in any direction throughout the pattern defined by the corner points specified in Table V-c for each such lamp when measured in accordance with the photometry test requirements of this standard.

Table V-b—Visibility Requirements of Installed Lighting Devices—Lens Area Visibility Option	Corner points <sup>1 2</sup>	Required visibility
Lighting device		



	Motorcycle	All other			
Turn signal lamp 3	15° UP-20° IB	15° UP-45° OB	15° UP-45° IB	15° UP-45° OB	Unobstructed minimum
	15° DOWN-20° IB	15° DOWN-45° OB	15° DOWN-45° IB	15° DOWN-45° OB	effective projected
Stop lamp	15° UP-45° RIGHT 4	15° UP-45° LEFT 4	15° UP-45° IB	15° UP-45° OB	luminous lens area
	15° DOWN-45° RIGHT 4	15° DOWN-45° LEFT 4	15° DOWN-45° IB	15° DOWN-45° OB	of 1,250 sq mm in any
Taillamp	15° UP-45° RIGHT 5	15° UP-45° LEFT 5	15° UP-45° IB	15° UP-45° OB	direction throughout
	15° DOWN-45° RIGHT 5	15° DOWN-45° LEFT 5	15° DOWN-45° IB	15° DOWN-45° OB	the pattern defined by
Parking lamp	No Requirement	No Requirement	15° UP-45° IB	15° UP-45° OB	the specified corner
	No Requirement	No Requirement	15° DOWN-45° IB	15° DOWN-45° OB	points.

1 IB indicates an inboard direction (toward the vehicle's longitudinal centerline) and OB indicates an outboard direction.

2 Where a lamp is mounted with its axis of reference less than 750 mm above the road surface, the vertical test point angles located below the horizontal plane subject to visibility requirements may be reduced to 5° down.

3 Where more than one lamp or optical area is lighted at the front on each side of a multipurpose passenger vehicle, truck, trailer, or bus, of 2032 mm or more overall width, only one such area need comply.

4 If a multiple lamp arrangement is used for a motorcycle stop lamp, the inboard angle for each lamp shall be 10 degrees.

5 If a multiple lamp arrangement is used for a motorcycle tail lamp, the inboard angle for each lamp shall be 45 degrees.



## Description of the Non-Compliance

In 2014, the MVSS regulation was updated for turn signal visibility. The updated regulation includes the requirement that the turn indicator should be visible on 45 degrees inboard and 15 degrees downwards. However, certain vehicle configurations within Volvo Group were not updated accordingly. As a result of an unrelated engineering change, Volvo Group identified that a non-compliance existed on certain vehicles where they were found to not be compliant with MVSS 108,6.4.3 turn signal visibility. The inboard and downward angle of compliance was non-compliant by 8 degrees inboard and 8 degrees downward. Please reference the below table to identify the degree per vehicle.

Model	Degrees	
	Inboard	Downward
GU Axle Back	37	15
GR Axle Back	37	15
GU Axle Forward	45	7
GR Axle Forward	45	7
GU Axle Forward Extended Frame Rail	45	7
GR Axle Forward Extended Frame Rail	45	7

*Table 1: Degree of non-compliance*

Illustration 1.

GR/GU 7 (illustration 1) is the axle forward configuration of the Granite truck platform:  
When configured in with a bumper and extended (front) frame it is not compliant with the updated regulation.

Extended Frame **X**

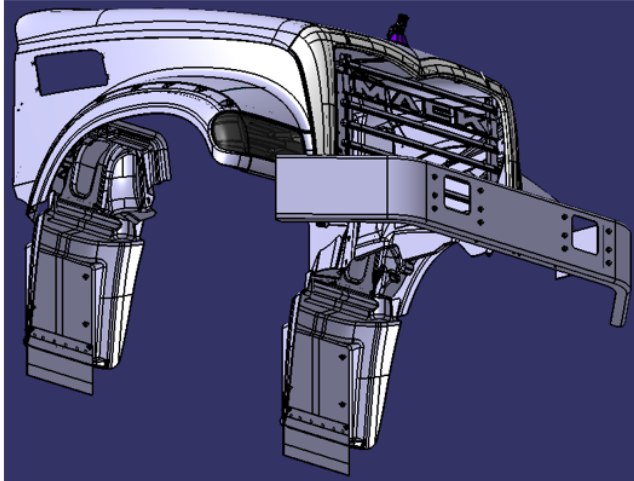

Normal Frame **✓**

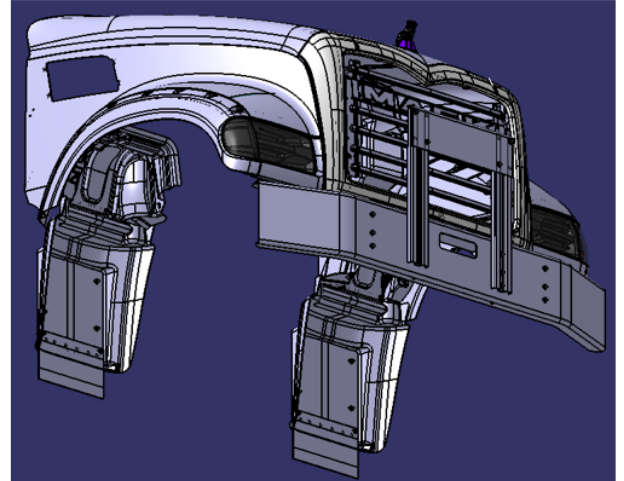
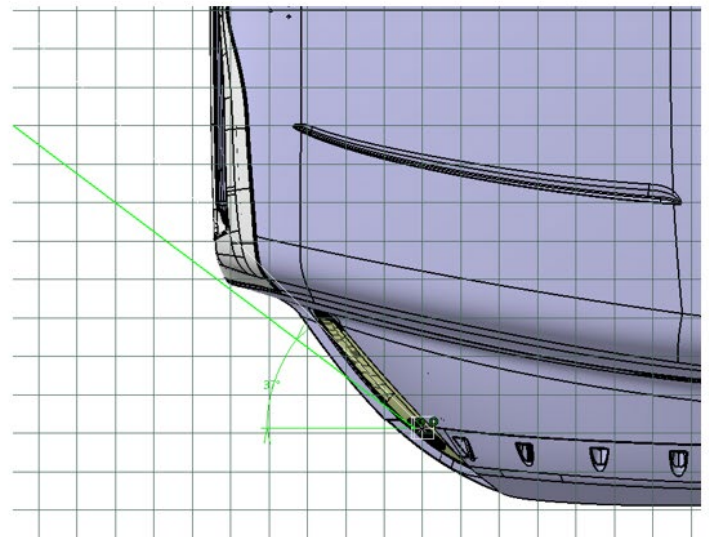
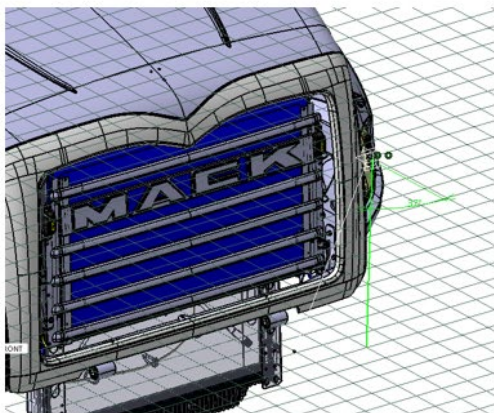
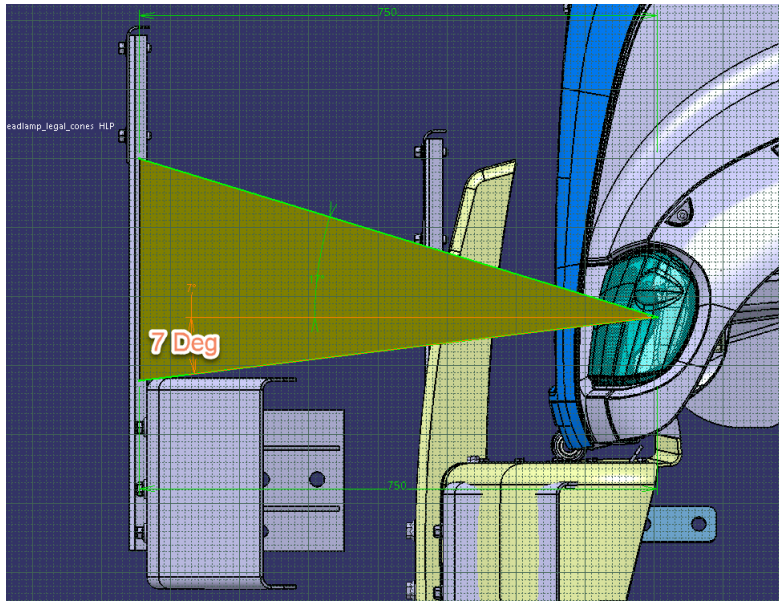

Illustration 2.

GR/GU 8 illustration 2 is the axle back configuration of the Granite truck platform:

37° is the max  
inboard visibility





**Period of Exemption Requested:** Mack is petitioning that all vehicles in the affected population be exempt from the recall requirements as the non-compliance is inconsequential to motor vehicle safety.

Please feel free to contact me if you have any questions.

Best regards,

*Emily Bishop*

Emily Bishop

Director, Vehicle Certification & Compliance

Complete Vehicle, USA

[emily.bishop@volvo.com](mailto:emily.bishop@volvo.com)

+1 301 5735972

7900 National Service Rd | Greensboro, NC, 27409 | USA | Volvo Group