



WARRANTY BULLETIN SAFETY CAMPAIGN

⚠ WARNING: All involved customers must be notified, all involved units must be corrected as per instruction herein.

Campaign no.: 2019-0018
2020-0009
2021-0005
2022-0012
2023-0001

October 31, 2022 Subject: **Front Fenders Electrical Harnesses May Be Loose – Potential Loss of Power**

No. **2023-1**

IMPORTANT

What should you do?

- Do not sell or deliver any involved vehicle that you have in stock as federal law requires you to complete the recall service on these vehicles before retail delivery.
- Unregistered vehicles cannot be sold until the campaign is performed.
- Contact all of your customers who purchased an affected vehicle and inform them about this Safety Recall notice.

MODEL YEAR	MODEL	ADMISSIBLE UNITS
2019 to 2021 2022 (Specific serial numbers) 2023 (Specific serial numbers)	Ryker®	Go to BOSSWeb/Warranty/Campaign Monitoring to know the quantity of units in your inventory impacted by this campaign

IMPORTANT

- When a vehicle comes in for service, always type the VIN in Knowledge Center to check for pending campaigns or alerts.
- When performing any work on a vehicle, it is good practice to connect it to BUDS2 to ensure that all needed updates are done.



PROBLEM

The position light and flasher electrical harness in the front fenders may be loose and rub on the tires. Over time, this could lead to a short circuit causing an engine stall while driving, without the ability to restart the vehicle. If this happens, the Vehicle Stability System (VSS), which includes the Anti-Lock Braking System (ABS) will not be available. This situation may increase the risk of a crash.

SOLUTION

Secure the harness with proper routing in the front fenders.

REQUIRED PARTS

DESCRIPTION	PART NUMBER	QTY
Locking tie 142mm X 3.2mm	293750002	8

NOTE: The parts for the repair will gradually be available.

CORRECTIVE ACTION

NOTE: LH side procedure shown, repeat for RH side.

1. Safely lift front of vehicle.
2. Remove RED locking clip, nut and wheel.
3. Remove and discard locking tie clip from the inside of the fender.

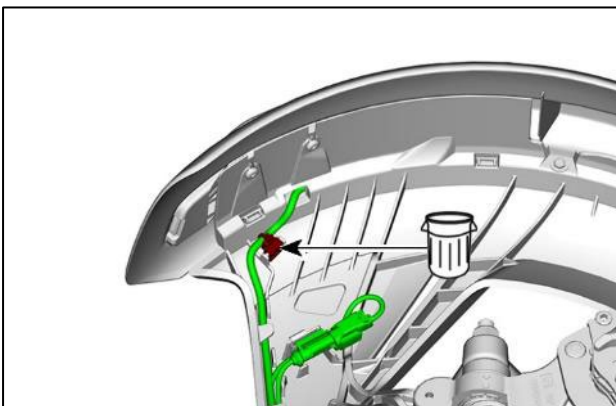

4. Inspect the harness condition. If it was previously damaged, it will need to be repaired.

NOTE: BRP will publish a separate quality bulletin for this repair.

5. Unclip harness connector and pull harness out of location to provide access for drilling.

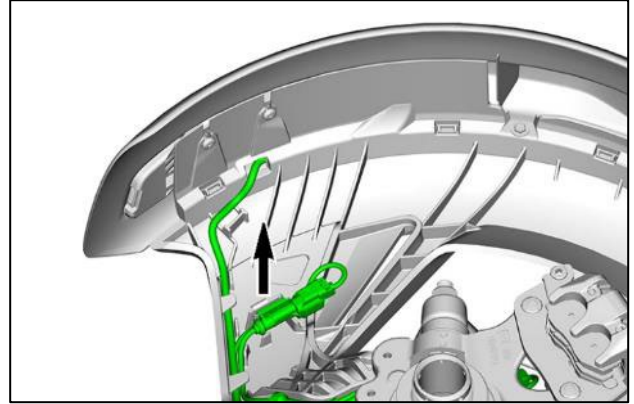

6. Drill 1/8 in (3 mm) holes in the four tabs at the following locations.

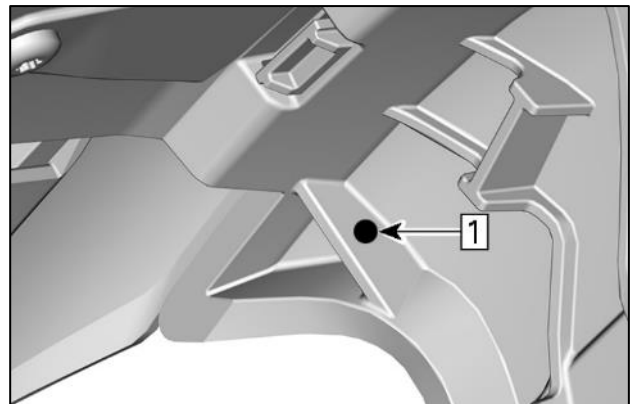
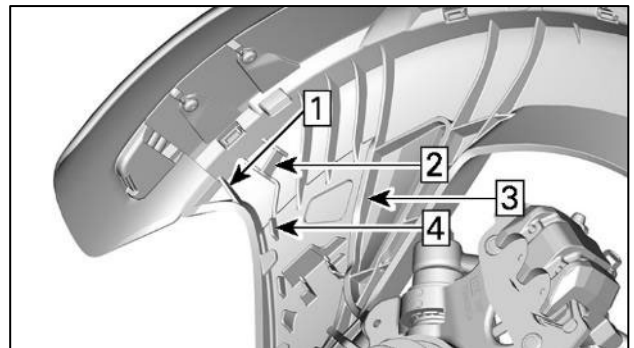

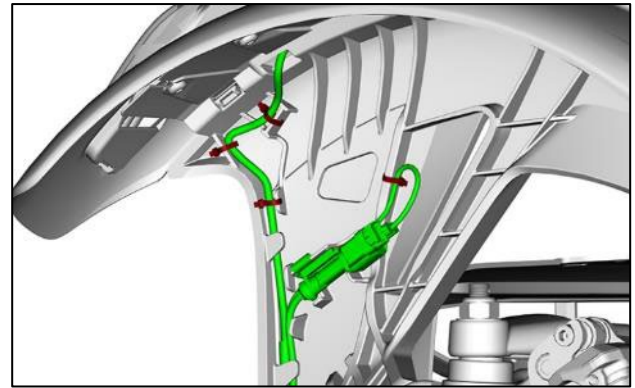
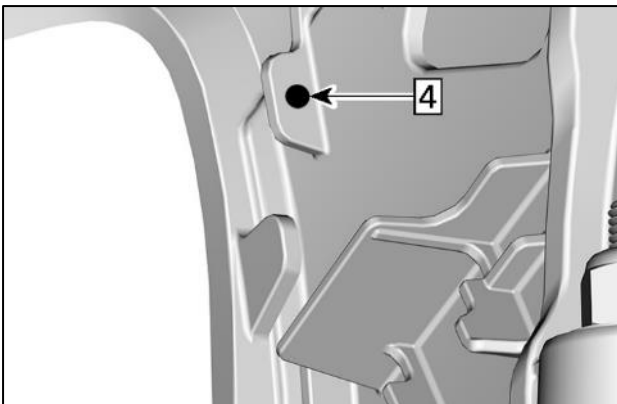
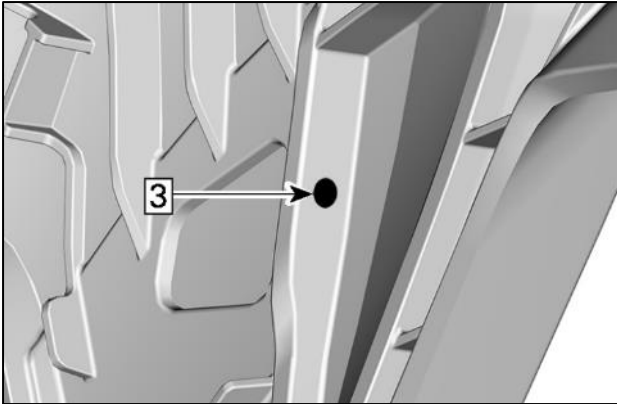
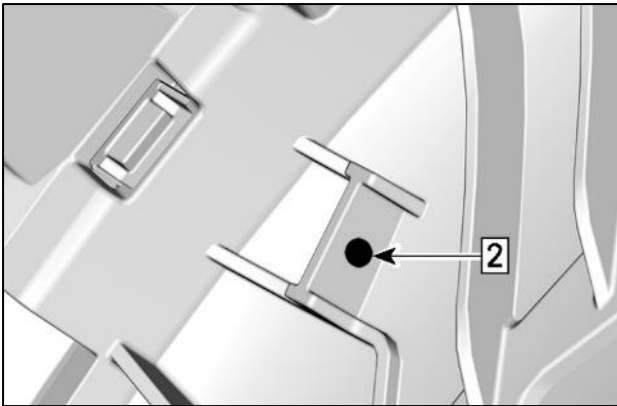

WHEEL INSTALLATION

1. Lock the wheel hub with a locking device (such as a long Allen key or a tempered steel rod).

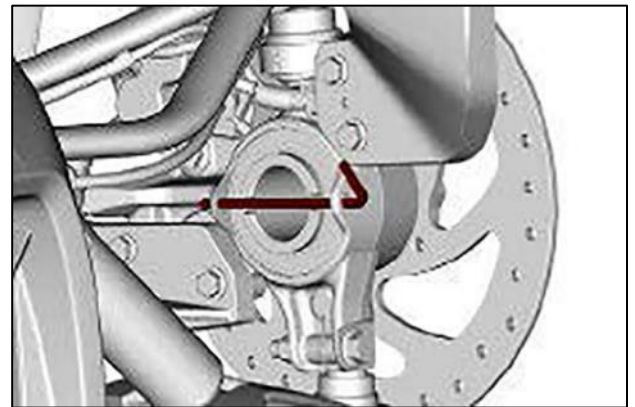

2. Install front wheel.
3. Align the dowel pins of the rim with the brake disc holes.

NOTICE All contact surfaces of the wheel, wheel hub, brake disc and the thread in the wheel hub must be free of abrasion, sand, dust or chips. Do not use fluids of any kind to wash the surfaces, use only dry soft cloth.

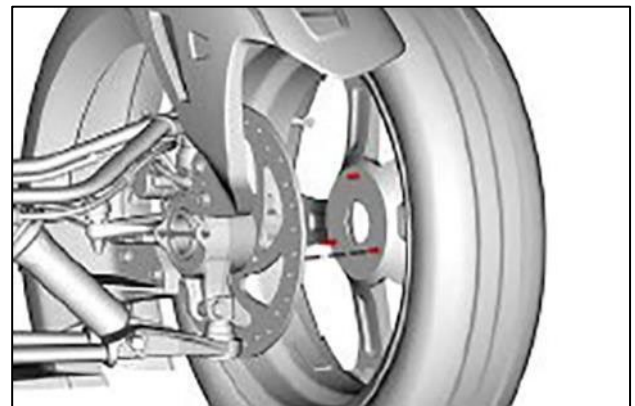

4. Install the conical washers and the center lock wheel nuts. Hand tighten.

NOTE: Use a 90 degree drill as the access is limited.

7. Route harness in place and clip connector.
8. Install new locking ties (1 at each drilling location to support the wiring harness properly). Cut exceeding length.
9. Ensure routing is as follows.

⚠ WARNING

MY22 and UP only: ensure to install the Counterclockwise center lock wheel nut on RH side and the Clockwise center lock wheel nut on LH side.

NOTICE MY22 and UP only: the front right wheel nut has left-hand threads. You must turn the nut counterclockwise to tighten it.



5. Lower the vehicle on the ground.
6. Tighten the center lock wheel nuts to specification.

NOTICE Never use impact tools to tighten wheel nuts.

REQUIRED TOOL

65MM SOCKET
(P/N 529 036 457)



TIGHTENING TORQUE

Center lock wheel nut	300N•m ± 15N•m 221lbf•ft ± 11lbf•ft)
-----------------------	---

7. Tighten the nut to the nominal value, then tighten further to align the hole.

NOTICE Never untighten the nut to align the RED locking clip hole.

⚠ WARNING

Failure to install the RED locking clip and/or not applying the proper torque to the wheel nut may cause the loss of a wheel.

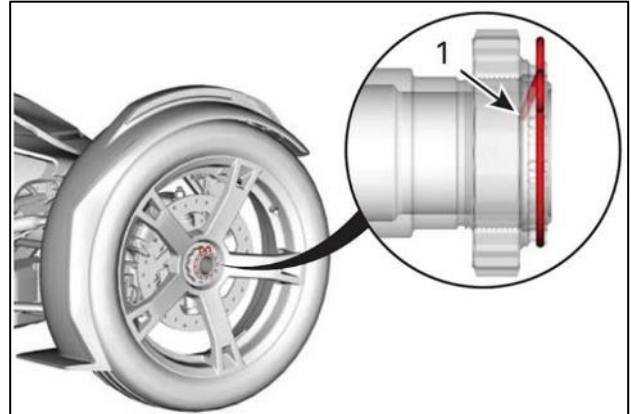

1. Folded end pointing inside the drive axle

8. Remove locking device from the wheel hub.

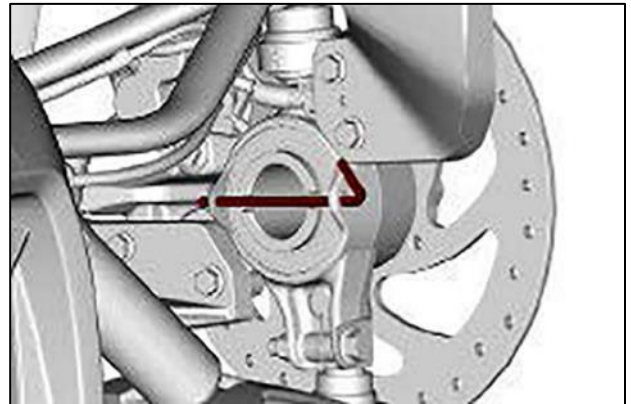

9. Install the inner hub cap by first inserting one locating pin, then insert the second one by pressing lightly on its tab. Ensure both pins are secured in place.



WARRANTY

Submit a warranty claim using the following information.

For claiming procedure, refer to the **online DEALER/DISTRIBUTOR WARRANTY GUIDE**.

MY2019 Models

Product Line	Roadster
Unit Model Year	2019
Campaign/Bulletin/Description	18 / 2023-1 / FRONT HARNESS ISSUE
*Action Inspect Repair <input type="checkbox"/> <input checked="" type="checkbox"/>	
Total Labor time paid	0.4 hour

MY2020 Models

Product Line	Roadster
Unit Model Year	2020
Campaign/Bulletin/Description	9 / 2023-1 / FRONT HARNESS ISSUE
*Action Inspect Repair <input type="checkbox"/> <input checked="" type="checkbox"/>	
Total Labor time paid	0.4 hour

MY2021 Models

Product Line	Roadster
Unit Model Year	2021
Campaign/Bulletin/Description	5 / 2023-1 / FRONT HARNESS ISSUE
*Action Inspect Repair <input type="checkbox"/> <input checked="" type="checkbox"/>	
Total Labor time paid	0.4 hour

MY2022 Models

Product Line	Roadster
Unit Model Year	2022
Campaign/Bulletin/Description	12 / 2023-1 / FRONT HARNESS ISSUE
*Action Inspect Repair <input type="checkbox"/> <input checked="" type="checkbox"/>	
Total Labor time paid	0.4 hour

MY2023 Models

Product Line	Roadster
Unit Model Year	2023
Campaign/Bulletin/Description	1 / 2023-1 / FRONT HARNESS ISSUE
*Action Inspect Repair <input type="checkbox"/> <input checked="" type="checkbox"/>	
Total Labor time paid	0.4 hour