

Safety Recall

Code: 20DS



Audi

REVISION

Subject	Fuel Tank Internal Vent Pipe															
Revision Date	March 28, 2023															
Revision Summary	Updated loaner claiming instructions (USA ONLY)															
Affected Vehicles	<table border="1"><thead><tr><th>Country</th><th>Beginning Model Year</th><th>Ending Model Year</th><th>Vehicle</th><th>Vehicle Count</th></tr></thead><tbody><tr><td>USA</td><td>2021</td><td>2022</td><td>Q3</td><td>13,004</td></tr><tr><td>CAN</td><td>2022</td><td>2022</td><td>Q3</td><td>3,059</td></tr></tbody></table> <p>Check Campaigns/Actions screen in Elsa on the day of repair to verify that a VIN qualifies for repair under this action. Elsa is the <u>only</u> valid campaign inquiry & verification source.</p> <ul style="list-style-type: none">✓ Campaign status must show "open."✓ If Elsa shows other open action(s), inform your customer so that the work can also be completed at the same time the vehicle is in the workshop for this campaign.	Country	Beginning Model Year	Ending Model Year	Vehicle	Vehicle Count	USA	2021	2022	Q3	13,004	CAN	2022	2022	Q3	3,059
Country	Beginning Model Year	Ending Model Year	Vehicle	Vehicle Count												
USA	2021	2022	Q3	13,004												
CAN	2022	2022	Q3	3,059												
Problem Description	The vent pipe within the fuel tank may have been damaged during fuel tank assembly. In cases where the vent pipe has been damaged, fuel might enter this pipe and rise to the fuel filler cap due to the pressure within the fuel tank. Upon opening the fuel filler cap, this might lead to fuel spilling out of the filler neck, increasing the risk of injury. Fuel within the vent pipe can also lead to the fuel pump clicking off while trying to re-fuel the vehicle.															
Corrective Action	The internal vent pipe will be checked for damage by pressurizing the fuel tank. In cases of fuel spilling out the fuel filler neck, the fuel tank and the charcoal canister will be replaced.															
Code Visibility	On or about October 18, 2022, the campaign code was applied to affected vehicles.															
Owner Notification	Owner notification took place in November 2022. Owner letter examples are included in this bulletin for your reference.															
Additional Information	<p>Please alert everyone in your dealership about this action, including Sales, Service, Parts and Accounting personnel. Contact Warranty if you have any questions.</p> <p>IMPORTANT REMINDER ON VEHICLES AFFECTED BY SAFETY & COMPLIANCE RECALLS</p> <p><u>New Vehicles in Dealer Inventory:</u> It is a violation of federal law for a dealer to deliver a new motor vehicle or any new or used item of motor vehicle equipment (including a tire) covered by this notification under a sale or lease until the defect or noncompliance is remedied. By law, dealers must correct, prior to delivery for sale or lease, any vehicle that fails to comply with an applicable Federal Motor Vehicle Safety Standard or that contains a defect relating to motor vehicle safety.</p> <p><u>Pre-Owned Vehicles in Dealer Inventory:</u> Dealers should not deliver any pre-owned vehicles in their inventory which are involved in a safety or compliance recall until the defect has been remedied.</p> <p>Dealers must ensure that every affected inventory vehicle has this campaign completed <u>before delivery to consumers.</u></p>															

Parts Information (if fuel tank requires replacement)

Parts Control Type: VIN to Order	If parts are needed to support a vehicle repair: <ul style="list-style-type: none"> • US Dealers - use AVA • CAN Dealers - contact the Parts Specialists via phone (800-767-6552), email (VWoAPartsSpecialists@vw.com), or chat/text with the VIN to order
---	--

Parts Control Type: Free Order	Parts will be managed by Free Order
---	-------------------------------------

Initial Allocation: NO	There will be no parts allocation. Please reference the Repair Projection Tool (below) to view your potential VIN population.
---	---

Repair Projection Tool: (right click to open)	
--	---

Criteria	Quantity	Part Number	P.O.C. Part Description	Ordering Method (see description above)
01	1.00	5QF-201-060-AN	TANK	VIN to Order
	1.00	3QF-201-797-D	EVAPCANIST	VIN to Order
	1.00	1J0-919-133-B	WASHER (fuel pump seal)	Free Order
	1.00	1K0-253-141-AA or 1K0-253-141-T	CLAMP (exhaust clamp) (see ETKA)	Free Order
	4.00	5G0-886-373	GROMMET (seat cushion)	Free Order
	3.00	N -103-291-02	BOLT (driveshaft)	Free Order
	1.00	N -106-284-01	BOLT (trailing arm to bearing housing)	Free Order
	2.00	N -106-998-01	BOLT (fuel tank filler neck)	Free Order
	1.00	N -107-695-01	SCREW (trailing arm)	Free Order
	4.00	N -906-484-02	BOLT (upper shock mount)	Free Order
	6.00	N -908-461-02	SCREW (driveshaft)	Free Order
	1.00	N -909-942-01	POP-RIVET (filler neck heat shield)	Free Order
	4.00	N -910-669-01	BOLT (driveshaft mount)	Free Order
	5.00	N -912-296-01	BOLT (fuel tank straps/mounting)	Free Order
	Up to 4.00	N -912-323-02	BOLT (seat frame)	Free Order
	3.00	WHT-005-179	SCREW (driveshaft)	Free Order
1.00	WHT-005-749	BOLT (trailing arm to bearing housing)	Free Order	

NOTE

The specified part numbers reflect the status at the start of this action. Interim updates made in ETKA can cause a listed part number to become unavailable. In this case, the new part number specified in ETKA should be used.

Claim Entry Instructions

The labor times listed here may differ from the labor operations and labor times listed in ELSA.

After campaign has been completed, enter claim as soon as possible to help prevent work from being duplicated elsewhere. Attach the Elsa screen print showing action open on the day of repair to the repair order.

If customer refused campaign work:

- ✓ U.S. dealers: Submit the request through Audi Warranty Online under the Campaigns/Update option.
- ✓ Canada dealers: Upload the repair order [signed by customer] to Audi WIN/Operations/Campaign Closure.

Service Number	20DS			
Damage Code	0099			
Parts Vendor Code	002			
Claim Type	Sold vehicle: 7 10 Unsold vehicle: 7 90			
Causal Indicator	Mark labor as causal if fuel tank is OK Mark TANK* as causal if fuel tank is NOT OK			
Vehicle Wash	Do not claim wash under this action			
Vehicle Loaner	See special claiming instructions for rental/loaner claiming. NOTE: A 2nd claim must be entered for rental/loaner claiming			
Vehicles may have more than one criteria. Complete and claim all applicable criteria on <u>one</u> claim.				
Criteria I.D.	01 ONLY			
	Perform test procedure to check for damaged vent line in fuel tank and fuel tank does not require replacement			
	LABOR			
	Labor Op	Time Units	Description	
	0183 00 99	610	Perform test, fuel tank OK	
	0150 00 99	Time stated on diagnostic protocol	Check and erase DTCs after testing	
	Outside Material			
	Quantity	Part number	Description	Amount
	1.00	FUEL	Fuel	Enter Total of both Receipts

Continued on next page

OR	Perform test procedure to check for damaged vent line in fuel tank and fuel tank requires replacement		
LABOR			
Labor Op	Time Units	Description	
2010 01 99	Up to 610	Perform test, fuel tank NOT OK	
2010 55 99	660	Replace fuel tank and charcoal canister	
0150 00 00	Time stated on diagnostic protocol	GFF Operations for all repairs/operations necessary	
PARTS			
Quantity	Part Number	Description	
1.00	5QF201060AN	TANK*	
1.00	1J0919133B	SEAL RING	
1.00	1K0253141AA or 1K0253141T	DUAL CLAMP (see ETKA)	
1.00	3QF201797D	EVAPCANIST	
4.00	5G0886373	GROMMET	
3.00	N 10329102	BOLT, HEX. HD. WITH SHOULDER	
1.00	N 10628401	BOLT, HEX. HD. WITH SHOULDER	
2.00	N 10699801	BOLT, HEX. HD. (COMBI.)	
1.00	N 10769501	SCREW, HEX. HD.	
4.00	N 90648402	BOLT, HEX. HD. (COMBI.)	
6.00	N 90846102	12 POINT SOCKET HEAD SCREW	
1.00	N 90994201	POP-RIVET	
4.00	N 91066901	BOLT, HEX. HD. WITH SHOUL. (COMBI.)	
5.00	N 91229601	BOLT	
Up to 4.00	N 91232302	BOLT	
3.00	WHT005179	12 POINT SOCKET HEAD SCREW	
1.00	WHT005749	FITTED BOLT, HEX. HEAD	
Outside Material			
Quantity	Part number	Description	Amount
1.00	FUEL	Fuel	Enter Total of both Receipts

Continued on next page

Criteria I.D.	01 and X2		
	Perform two test procedures to check for damaged vent line in fuel tank and fuel tank does not require replacement		
	LABOR		
	Labor Op	Time Units	Description
	0183 01 99	1220	Perform tests, fuel tank OK
	0150 00 99	Time stated on diagnostic protocol	Check and erase DTCs after testing
	Outside Material		
	Quantity	Part number	Description
	1.00	FUELX2	Fuel
			Enter Total of all Receipts
OR	Perform two test procedures to check for damaged vent line in fuel tank and fuel tank requires replacement		
	LABOR		
	Labor Op	Time Units	Description
	2010 02 99	Up to 1220	Perform tests, fuel tank NOT OK
	2010 55 99	660	Replace fuel tank and charcoal canister
	0150 00 00	Time stated on diagnostic protocol	GFF Operations for all repairs/operations necessary
	PARTS		
	Quantity	Part Number	Description
	1.00	5QF201060AN	TANK*
	1.00	1J0919133B	SEAL RING
	1.00	1K0253141AA or 1K0253141T	DUAL CLAMP (see ETKA)
	1.00	3QF201797D	EVAPCANIST
	4.00	5G0886373	GROMMET
	3.00	N 10329102	BOLT, HEX. HD. WITH SHOULDER
	1.00	N 10628401	BOLT, HEX. HD. WITH SHOULDER
	2.00	N 10699801	BOLT, HEX. HD. (COMBI.)
	1.00	N 10769501	SCREW, HEX. HD.
	4.00	N 90648402	BOLT, HEX. HD. (COMBI.)
	6.00	N 90846102	12 POINT SOCKET HEAD SCREW
	1.00	N 90994201	POP-RIVET
	4.00	N 91066901	BOLT, HEX. HD. WITH SHOUL. (COMBI.)
	5.00	N 91229601	BOLT
	Up to 4.00	N 91232302	BOLT
	3.00	WHT005179	12 POINT SOCKET HEAD SCREW
	1.00	WHT005749	FITTED BOLT, HEX. HEAD

Continued on next page

	Outside Material			
	Quantity	Part number	Description	Amount
	1.00	FUELX2	Fuel	Enter Total of all Receipts

-AND-	Add as needed for ALL vehicles depending on vehicle axle alignment		
	LABOR		
	Labor Op	Time Units	Description
	4495 03 00	90	Vehicle alignment front + rear measure
	9092 00 50	30	Preparation Driver Assist Calibration
	<i>NOTE: LO 9092 00 50 can be claimed more than once if multiple driver assist preparations are needed</i>		
	<i>ADD as needed:</i>		
	4488 15 99	20	Front wheel track adjust
	4489 15 99	20	Front wheel camber adjust
	4493 15 99	30	Rear wheel track adjust
	4494 15 99	20	Rear wheel camber adjust
	9163 15 99	40	Adaptive Cruise Control (ACC) System Adjust
9638 15 99	40	Camera Driver Assist System Adjust	

Continued on next page

Vehicles with Criteria 01 ONLY (USA and Canada)			
Vehicle Loaner	Enter vehicle loaner claim as a separate (2nd) claim Inspection only = Up to 1 day Inspection + fuel tank replacement = up to 3 days		
	Claim Type	7 MO	(letter O, not number 0)
	Service Number	20DS	
	Damage Code	0010	
	Parts Vendor Code	002	
	Outside Labor Operation	LOAN1600	Enter dollar amount on rental/loaner invoice (\$50 max per day)

Vehicles with Criteria 01 and X2 ONLY (USA ONLY)			
<ul style="list-style-type: none"> • Applies only to vehicles that are waiting on a fuel tank based on the original test results and/or awaiting finalization of the second test with a repair order open as of 03/28/2023 • Cannot be applied to previously closed/claimed campaigns 			
Vehicle Loaner	Enter vehicle loaner claim as a separate (2nd) claim The total number of days includes, initial testing, time down while waiting for fuel tank, second testing procedure, and fuel tank replacement (if required)		
	Claim Type	7 MO	(letter O, not number 0)
	Service Number	20DS	
	Damage Code	0010	
	Parts Vendor Code	002	
	Outside Labor Operation	LOAN16DB	Enter dollar amount on rental/loaner invoice (\$50 max per day)

Customer Letter Example (USA)

<MONTH YEAR>

<CUSTOMER NAME>

<CUSTOMER ADDRESS>

<CUSTOMER CITY STATE ZIPCODE>

This notice applies to your vehicle: <MODEL YEAR> <BRAND> <CARLINE>, <VIN>

NHTSA: 22V673

Subject: Safety Recall 20DS - Fuel Tank Internal Vent Pipe

Dear Audi Owner,

This notice is sent to you in accordance with the National Traffic and Motor Vehicle Safety Act. Audi has decided that a defect, which relates to motor vehicle safety, exists in certain 2021-2022 model year Audi vehicles. Our records show that you are the owner of a vehicle affected by this action.

What is the issue? The vent pipe within the fuel tank may have been damaged during fuel tank assembly. In cases where the vent pipe has been damaged, fuel might enter this pipe and rise to the fuel filler cap due to the pressure within the fuel tank. Upon opening the fuel filler cap, this might lead to fuel spilling out of the filler neck, increasing the risk of injury. Fuel within the vent pipe can also lead to the fuel pump clicking off while trying to re-fuel the vehicle.

What will we do? To correct this defect, your authorized Audi dealer will check the internal vent pipe for damage by pressurizing the fuel tank. In cases of fuel spilling out the fuel filler neck, the fuel tank and the charcoal canister will be replaced. This testing will take about one day for your dealer to complete.

If testing shows that fuel tank and charcoal canister replacement is necessary, the replacement will take about a day to complete once your dealer has received the parts needed to complete the work.

Both the testing and parts replacement (if needed) will be performed for you free of charge. Please keep in mind that your dealer may need additional time for the preparation of the repair, as well as to accommodate their daily workshop schedule.

What should you do? If possible, please ensure the fuel tank in your vehicle is between one-half and three-quarters full when you arrive at the dealership for this recall work.

Please contact your authorized Audi dealer without delay to schedule this recall work. For your convenience, you can also visit www.audiusa.com and click on the "Find a Dealer" link to locate a dealer near you and schedule this service.

Lease vehicles and address changes If you are the lessor and registered owner of the vehicle identified in this action, the law requires you to forward this letter immediately via first-class mail to the lessee within ten (10) days of receipt. If you have changed your address or sold the vehicle, please fill out the enclosed prepaid Owner Reply card and mail it to us so we can update our records.

Can we assist you further? If your authorized Audi dealer fails or is unable to complete this work free of charge within a reasonable time, please contact Audi Customer Experience at 1-800-253-2834 or via our "Contact Us" page at www.audiusa.com.

Checking your vehicle for open Recalls and Service Campaigns To check your vehicle's eligibility for repair under this or any other recall/service campaign, please visit the **Recall/Service Campaign Lookup** tool at www.audiusa.com and enter your Vehicle Identification Number (VIN).

If you still cannot obtain satisfaction, you may file a complaint with: The Administrator, National Highway Traffic Safety Administration, 1200 New Jersey Avenue, SE., Washington, DC 20590; or call the toll-free Vehicle Safety Hotline at 1-888-327-4236 (TTY: 1-800-424-9153); or go to <http://www.safercar.gov>.

We apologize for any inconvenience this matter may cause; however we are taking this action to help ensure your safety and continued satisfaction with your vehicle.

Sincerely,

Audi Customer Protection

Customer Letter Example (Canada)

<MONTH YEAR>

<CUSTOMER NAME>

<CUSTOMER ADDRESS>

<CUSTOMER CITY STATE ZIPCODE>

This notice applies to your vehicle: <MODEL YEAR> <BRAND> <CARLINE>, <VIN>

Transport Canada Recall: 2022-503

Subject: Safety Recall 20DS - Fuel Tank Internal Vent Pipe

Dear Audi Owner,

This notice is sent to you in accordance with the requirements of the *Motor Vehicle Safety Act*. This is to inform you that your vehicle may contain a defect that could affect the safety of a person. Our records show that you are the owner of a vehicle affected by this action.

What is the issue? The vent pipe within the fuel tank may have been damaged during fuel tank assembly. In cases where the vent pipe has been damaged, fuel might enter this pipe and rise to the fuel filler cap due to the pressure within the fuel tank. Upon opening the fuel filler cap, this might lead to fuel spilling out of the filler neck, increasing the risk of injury. Fuel within the vent pipe can also lead to the fuel pump clicking off while trying to re-fuel the vehicle.

What will we do? To correct this defect, your authorized Audi dealer will check the internal vent pipe for damage by pressurizing the fuel tank. In cases of fuel spilling out the fuel filler neck, the fuel tank and the charcoal canister will be replaced. This testing will take about one day for your dealer to complete.

If testing shows that fuel tank and charcoal canister replacement is necessary, the replacement will take about a day to complete once your dealer has received the parts needed to complete the work.

Both the testing and parts replacement (if needed) will be performed for you free of charge. Please keep in mind that your dealer may need additional time for the preparation of the repair, as well as to accommodate their daily workshop schedule.

What should you do? If possible, please ensure the fuel tank in your vehicle is between one-half and three-quarters full when you arrive at the dealership for this recall work.

Please contact your authorized Audi dealer without delay to schedule this recall work.

Lease vehicles and address changes If you are the lessor and registered owner of the vehicle identified in this letter, you shall forward this letter (and any subsequent notice, if applicable) to the lessee within ten (10) days of receipt. If you have changed your address or sold the vehicle identified in this letter, please fill out the enclosed prepaid Owner Reply Card and mail it to us so we can update our records.

Can we assist you further? If your authorized Audi dealer fails or is unable to complete this work free of charge within a reasonable time, please contact Audi Customer Relations Monday through Friday from 8AM to 8PM EST at 1-800-822-2834 or via our "Contact Audi Canada" page at www.audi.ca.

We apologize for any inconvenience this matter may cause; however we are taking this action to help ensure your safety and continued satisfaction with your vehicle.

Sincerely,

Audi Customer Protection

Repair Overview



- Perform test procedure to check for a hole in the fuel tank vent line.
- Replace fuel tank, if necessary.

IMPORTANT

Vehicles assigned Criteria X2 are vehicles that originally failed the fuel tank testing based on the original testing procedures. These vehicles require a new test with the updated test procedure.

NOTE

- These repair instructions may differ from the labor operations and labor times listed in ELSA.
- Damages resulting from improper repair or failure to follow these work instructions are the dealer's responsibility and are not eligible for reimbursement under this action.
- This procedure must be read in its entirety prior to performing the repair.
- Due to variations in vehicle equipment and options, the steps/illustrations in this work procedure may not identically match all affected vehicles.
- Diagnosis and repair of pre-existing conditions in the vehicle are not covered under this action.
- When working during extreme temperatures, it is recommended that the vehicle be allowed to acclimate inside the shop to avoid temperature-related component damage/breakage.

Required Tools and Equipment

 <p>EVAP Adapter Kit KLI 9210/56-1</p>	 <p>Two gas cans capable of holding at least 5 gallons (~20 L) each. (locally sourced)</p>
 <p>Fuel safe hose (approx. 3 feet / 1 meter long) 3/8" inner diameter (locally sourced)</p>	 <p>Two grounding cables with crocodile clips on each end</p>
 <p>Storage Tub (gas cans will be placed in tub to catch any additional fuel overflow)</p>	 <p>Hose clamp N 90770201</p>
 <p>Fuel Extractor -VAS 5190A-</p>	

Repair Instruction

Section A - Check for Previous Repair

Applicable criteria ID(s)	Campaign/Action Status
01 ← 2	Open ← 1

EXAMPLE

Campaign/Action	Start	Designation
← 3	2015-11-10	W-SERV_ACT -
	2018-12-13	RECALL -
	2017-05-16	A-RECALL -

EXAMPLE

- Enter the VIN in Elsa and proceed to the “Campaign/Action” screen.

TIP

On the date of repair, print this screen and keep a copy with the repair order.

- Confirm the Campaign/Action is open <arrow 1>. If the status is closed, no further work is required.
- Note the Applicable Criteria ID <arrow 2> for use in determining the correct work to be done and corresponding parts associated.

CRITICAL REPAIR STEP

 **STOP!** 

If multiple software update Campaign/Actions are open, they must be performed in order of the Start date <arrow 3>. The oldest should be performed first.

- **All Safety Recalls must be completed prior to completing this campaign.**
- **Proceed to Section B.**

IMPORTANT

Vehicles assigned Criteria X2 are vehicles that originally failed the fuel tank testing based on the original testing procedures. These vehicles require a new test with the updated test procedure.

Section B – Fuel Tank Overflow Test

WARNING

The fuel system is under pressure. Injuries are possible from fuel spraying out.

Before opening the fuel system:

Wear protective eyewear.

Wear safety gloves.

Place clean cloths around the connection points and carefully open the connection points.

The following conditions **MUST** be met before starting the test procedure:

- Document the amount of fuel currently in the vehicle.
- Adjust the fuel level as follows:
 - **REMOVE** the amount of fuel indicated in the chart below.

Fuel Gauge Reading	Amount of Fuel to Remove*	Amount of Fresh Fuel to Add +/- 0.1 gallons (0.4 L)
1 bar + flashing red	NONE	10 gallons (37.6 L)
1 bar	NONE	9 gallons (34.0 L)
2 bar	NONE	7.5 gallons (28.4 L)
3 bar	NONE	5.5 gallons (20.8 L)
4 bar	NONE	3.5 gallons (13.2 L)
5 bar	NONE	3 gallons (11.4 L)
6 bar	2 gallons (7.6 L)	3 gallons (11.4 L)
7 bar	4.5 gallons (17 L)	3 gallons (11.4 L)
8 bar	6 gallons (22.7 L)	3 gallons (11.4 L)

- Add **FRESH** fuel in the amount indicated in the chart above.
- Use a gas station closest to the dealer.
- If possible, use a known good fuel pump that does not switch off prematurely.
- Drive to and from the gas station as moderately as possible.
- *Refer to the ELSA Repair Manual if fuel requires removal.
- The refueling must be done accurately, with a maximum deviation of +/- 0.1 gallons (0.4 L)
- Park the vehicle in the workshop overnight in order to acclimate to the indoor ambient temperature.
- The ambient temperature of the workshop area where the test is to be performed must be above 68° F (20°C).
- The vehicle must be parked on a level surface.

NOTE

If the fuel station fill nozzle switches off prematurely when attempting to fill the fuel tank at the beginning of the test, the fuel tank and charcoal canister will require replacement.

NOTE

When returning the vehicle to the customer, the fuel fill level should be equal to what the fuel level was when the vehicle arrived.



Test procedure:

WARNING

There is a risk of the fuel tank exploding due to electrostatic discharge.

Severe injuries and burns are possible.

Attach the fuel collection cans via a ground cable to a bare area on the body.

- Place the two fuel cans inside a tub.
- Ground the fuel cans to the vehicle.

WARNING

Risk of a fire due to leaking fuel.

Leaking fuel may ignite and start a fire.

Have cloths ready to catch any leaking fuel.

- Close the hood and all doors.
- Remove fuel cap.
- Attach EVAP test adapter - KLI 9210/56-1 - in place of the fuel cap.
- Attach a length of fuel safe hose to the -KLI9210/56-1- adapter and secure with clamp N -907-702-01.
- The other end of the hose should be placed in one of the fuel cans.
- Start the engine and allow vehicle to idle.
- Ensure the exhaust is properly vented.
- Monitor if fuel drains out of the fuel tank, through the test hose for up to 5.5 hours.
- Check the container every 15 to 30 minutes for fuel draining from the test hose.

The determining factors if a tank requires replacement are as follows:

- Amount of fuel collected over the 5.5 hour test period.
- Fuel station nozzle filling results.

NOTE

How this test works to evaluate a NOK fuel tank:

- As the vehicle runs, the exhaust will heat the fuel inside the fuel tank and the running of the fuel pump will create fuel vapors.
- If a hole is present in the vent line located inside the fuel tank, the pressure from the fuel vapor will force the fuel through the hole in the vent line.
- The fuel would then be forced into the fuel tank vent pipe <A>.
- Once vent pipe <A> is filled, the fuel will enter and the fuel tank filler neck pipe through an opening between the pipes <C>.
- Once the fuel tank filler neck pipe is filled with fuel, the fuel would then overflow out of the fuel tank.
- Liquid fuel would then be present inside the filler neck tube (see examples below).

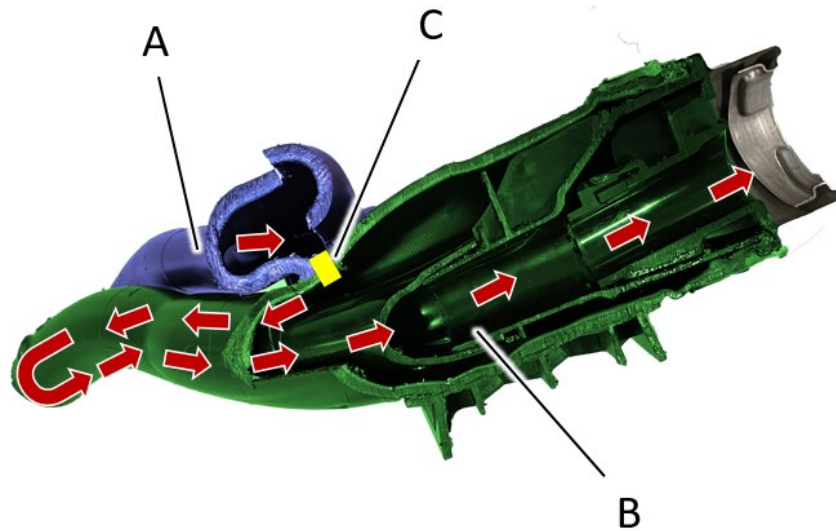

Example photos of filler neck with liquid fuel present due to overflow in filler neck:

(This indicates a failed fuel tank vent hose)

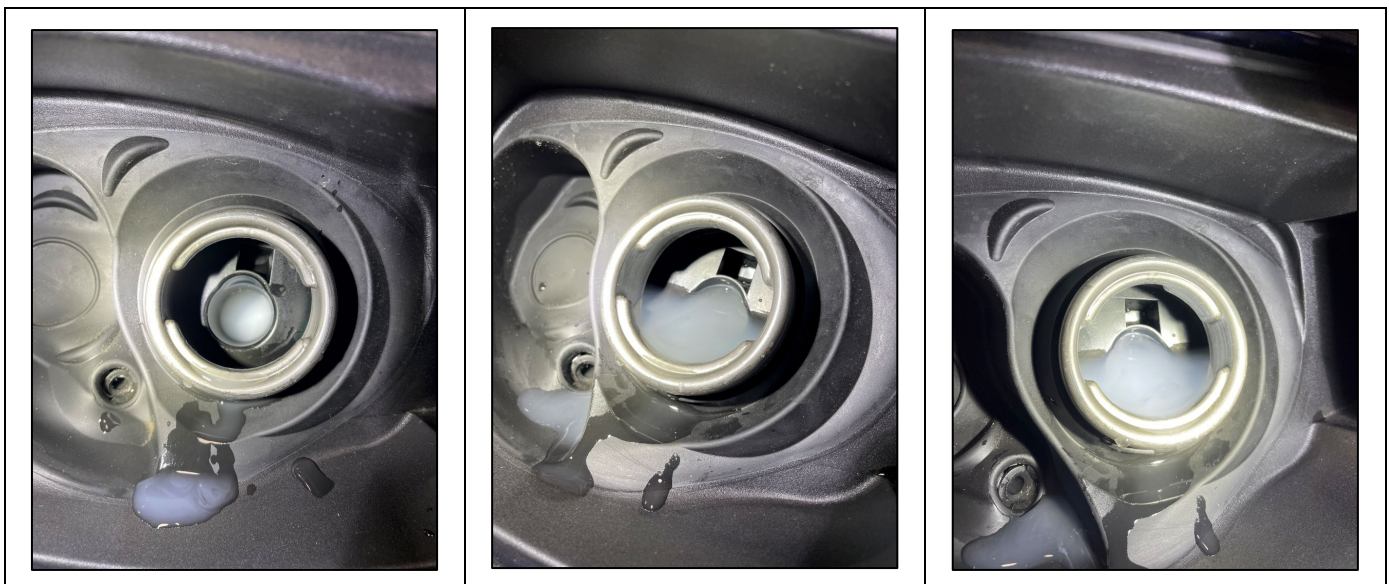

NOTE

Fuel vapor in the test hose coming from the filler tube or vent system can condensate, based on certain conditions (ambient temperature, floor temperature, fuel quality, type of fuel), and produce the presence of fuel that could be mis-interpreted as overflow.
See example photos below.

Example photos of filler neck with NO liquid fuel present:

(This does not indicate a failed fuel tank vent hose. However, an additional test will be required)

No fuel in filler neck opening <1>. Fuel condensation present in the drain area <2> of the filler neck.

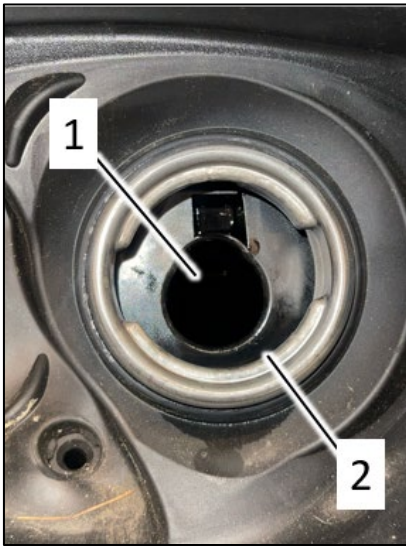

No fuel in filler neck opening <1>.

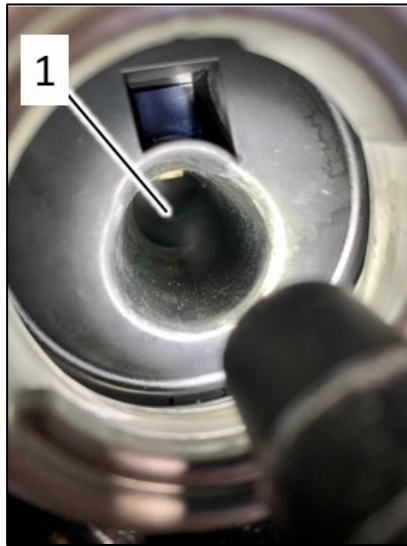

Fuel condensation formed on adapter cap <1>.

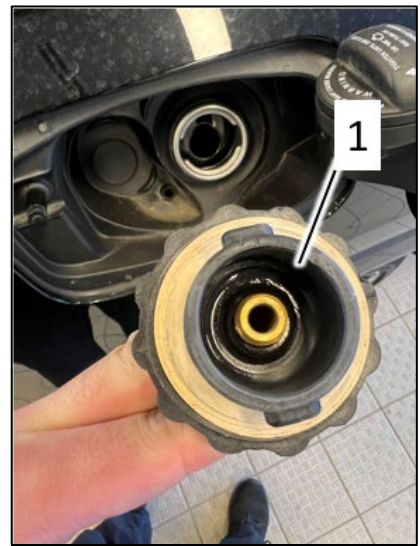

Amount of Fuel Collected Evaluation:

⚠ WARNING

Risk of a fire due to leaking fuel.

Leaking fuel may ignite and start a fire.

Be prepared to immediately reinstall the adapter cap in the event the fuel tank is overflowing.

! NOTE

Opening <A> is the filler neck opening.

Area is a drain area for the filler neck.

When checking for fuel, look down the filler neck opening <A>.

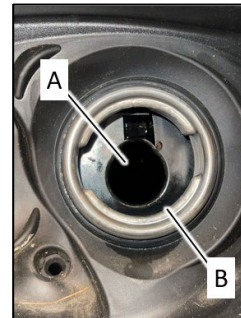

Less than 230 ml (8 fl. oz./1 cup) collected or only droplets of fuel observed:

- Fuel collected may be a result of fuel condensation during the test.
- Wear gloves and have collection rags prepared to catch any leaking fuel.
- Remove the fuel cap test adapter and check for liquid fuel in the fuel filler neck (see example photos below).
Be prepared to immediately reinstall the adapter cap in the event the fuel tank is overflowing.
- If there is no liquid fuel present in the fuel filler neck:
 - A fuel fill test is required.
 - **Proceed to Section C**
- If liquid fuel is present in the filler neck:
 - The fuel tank and charcoal canister require replacement.
 - **Proceed to section D**

NO fuel drains out of the fuel tank test hose after 5.5 hours:

- A fuel fill test is required.
- **Proceed to Section C**

Steady stream of fuel coming from adapter hose:

- Fuel tank vent hose is **NOT OK**.
- Fuel tank and charcoal canister require replacement.
- **Proceed to Section D**

! NOTE

In the event of an overflow, fuel will continue to leak after the engine has been switched off. Do not close the tank, but wait for the end of the overflow and change the container capturing the fuel, if necessary.

After turning off the engine, the overflow should stop after 30 minutes. The maximum amount of fuel that could overflow is up to 13.2 gallons (50 L) (depending on the amount of fuel at the beginning of the test and the damaged area in the venting system).

Section C – Fuel Fill Test

- Remove test equipment.
- Reinstall fuel cap.
- Drive to closest gas station as moderately as possible.
- Attempt to fill with no more than two gallons (~7.5L) while observing the following:
 - Use a fuel station with known good fuel pumps.
 - Fuel vehicle with fuel nozzle fully open so there is a steady flow of fuel.
 - Fuel fill nozzle must be fully inserted.
 - Nozzle must be at the 6 o'clock position.

Fuel Fill Test Evaluation:

NOTE

The fuel tank will be nearly full at the beginning of the fill test. The concept of the fill test is to see if the tank will accept a constant flow of fuel.

Fuel pump switches off prematurely when attempting to fill:

- The fuel tank vent hose is **NOT OK.**
- The fuel tank and charcoal canister require replacement.
- **Proceed to Section D.**

Fuel pump does not switch off prematurely:

- The fuel tank vent hose is **OK.**
- No further work is required.
- **Proceed to Section E.**

NOT OK



OK

Section D – Replacing Fuel tank

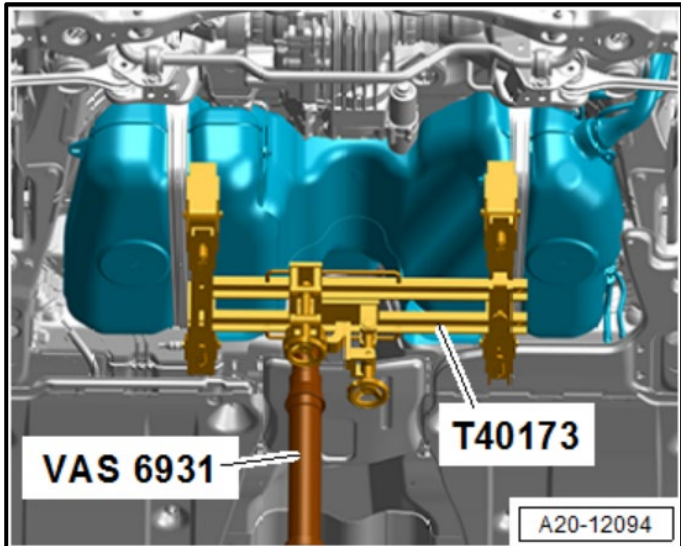

- Refer to the Repair Manual for all warnings safety, safety precautions and guidelines for clean working conditions.
- Replace fuel tank.
- See ELSA Repair Manual: *Repair manual > Engine > Fuel Supply System > 20 Fuel Supply > Fuel Tank > Fuel Tank, Removing and Installing*

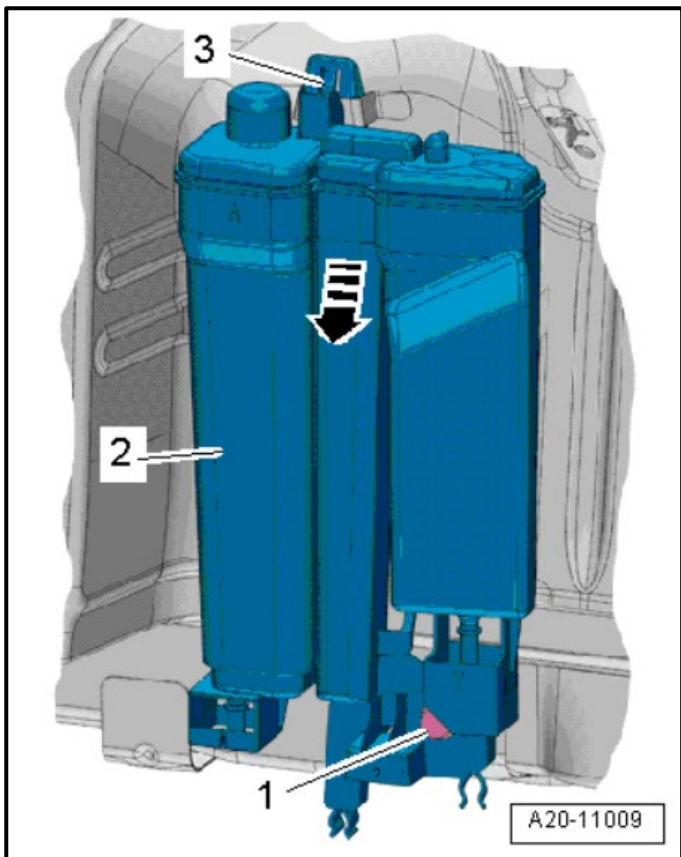

- Replace EVAP (charcoal) canister.
- See ELSA Repair Manual: *Repair manual > Engine > Fuel Supply System > 20 Fuel Supply > EVAP System > EVAP Canister, Removing and Installing*

Proceed to Section E

Section E – Campaign Completion Stamp

I certify that this campaign
has been performed in strict
accordance with the applicable
Audi repair procedure.

SAGA Code: _____
Technician: _____
Date: _____

Item#: AUD4927ENG

-OR-

Je certifie que cette
campagne de rappel a été
exécutée suivant les strictes
directives de réparation
d'Audi

Code de SAGA: _____
Technicien: _____
Date: _____

Item # AUD4927FRE

- Once the campaign has been completed, the technician should stamp the repair order.
- Stamps are available for ordering through the Compliance Label Ordering Portal.

Proceed to Section F

Section F - Parts Return/Disposal

Properly store (retain), destroy or dispose of removed parts in accordance with all state/province and local requirements, unless otherwise indicated and/or requested through the Warranty Parts Portal (WPP) for U.S. and the Part Destruction and Core Disposition Report for Canada.