



SIB 61 06 22

RECALL 22V-672: REPLACE HORN MOUNTING SCREW

2022-09-09

Model	Model Description	Production Date
K07	CE-04	8/31/21-8/29/22

The affected vehicles have been marked with campaign number **0000611700** in AIR.

In order to determine if a specific vehicle is affected by this campaign, it will be necessary to verify the vehicle VIN in AIR (Aftersales Information Research). Based on the response of the system, either proceed with the repair or take no further action. Please note, open campaigns or vehicle stops may not appear in DCS Warranty Vehicle Inquiry or sales systems until 24-72 hours after they are announced, therefore AIR is always the recommended method for determining open campaigns and vehicle stops.

NHTSA STATEMENT

Please be reminded that it is a violation of federal law (The Safety Act) for you to sell, lease or deliver any new motorcycle covered by this notification until the recall repair has been performed. This means that dealers may not legally deliver new motorcycles to consumers until they are fixed or use/sell replacement equipment/parts subject to this recall. Note also that substantial civil penalties apply to violations of the Safety Act. Also, you should not sell, lease or deliver any used motorcycles subject to a safety recall until the repair is completed. Please follow any special instructions that we provide to you for the return or disposition of recall parts.

SITUATION

The Screw (Item 2) of the screw connection to the frame is short. Under certain circumstances the screw may come loose and drop down causing a restriction in the left turn steering angle.

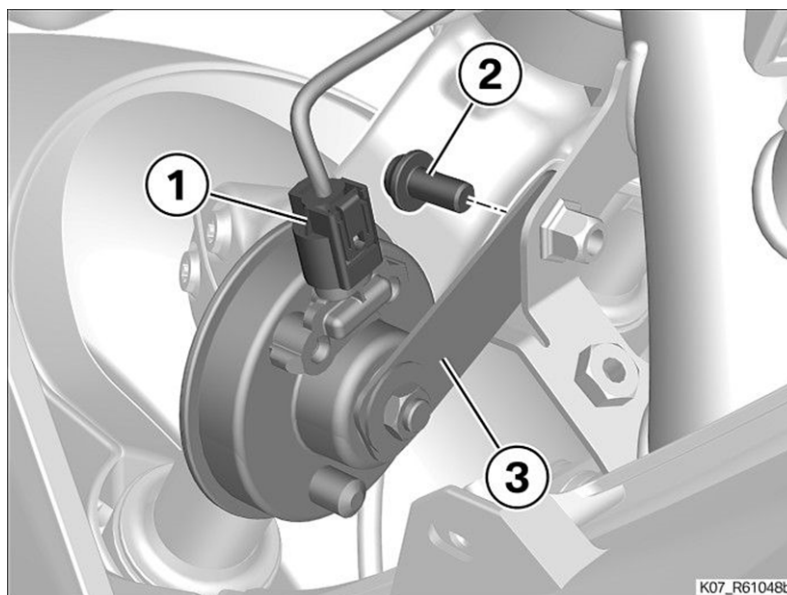

CORRECTION

The short screw for attaching the horn must be replaced with a new longer screw, according to the repair operation "61 33 011 Replacing the horn".

PARTS INFORMATION

Obtain and confirm the part numbers for your specific vehicle by entering the chassis number in ETK which takes into account specific equipment and/or options.

Additional parts like gaskets, hardware and chemicals may be required for the complete repair.

Part Number

07 12 9 908 415	Fillister-Head Screw M8x20-8.8-MK
-----------------	-----------------------------------

CLAIM INFORMATION

Please submit claims via the normal claim process using the information below:

Defect code

00 00 61 17 00	Replace Horn Mounting Screw
----------------	-----------------------------

Labor Operation

00 60 410	Replace Horn Screw	5 FRU
+00 60 910	Replace Horn Screw	4 FRU

FRUs includes all repair procedures to complete the task with allowance for necessary ancillary tasks (e.g., visual inspection, lubrication, cleaning parts etc.) and administrative tasks.

Labor operation code 00 60 410 is a Main labor operation. If you are using a Main labor code for another repair, use the Plus code labor operation instead.

TREAD Act Reimbursement - Qualifying Prior Customer-Pay Repairs

If your center is presented with a reimbursement request, BMW of North America, LLC will reimburse qualifying customer-pay repairs that were performed on affected vehicles up to 10 days after the date the owner notification letter was sent out by BMW.

If the customer previously paid for a qualifying repair, verify in AIR that the VIN is affected by the recall campaign and proceed as applicable:

The customer arrives with an affected vehicle to your workshop

- Perform the open Recall repair outlined in this bulletin, regardless of previous repair history.
- If the prior repair qualifies (see below), submit for both the Recall repair and the customer-pay reimbursement (Separate repair line items/separate defect codes).

Or:

The customer only presents your center with a customer-pay invoice for the prior repair

- If the vehicle and the prior repair qualifies (see below), submit for the customer-pay reimbursement portion only.

Customer-pay Invoice Review and Reimbursement Qualification and Procedure

Review and verify that the prior customer-pay invoice (BMW center or independent repair shop) contains a repair that pertains to the recall campaign. Only the repair outlined in the published safety recall service bulletin is eligible for reimbursement.

If this prior repair qualifies, submit a claim for reimbursement:

- Verify in AIR that the VIN was affected by the recall campaign
- Use defect code 85 99 00 45 NA for the amount requested under sublet 03.
- Comment: RECALL 22V-672 Replace Horn Mounting Screw - Reimbursement for allowable expenses that relate to performing the prior qualifying customer-pay repair.
- Use current repair date and mileage for claim submission.
- Retain copies of the customer paid invoice and the current repair invoice in your records.
- Reimburse the customer directly (parts and labor).

Contact warranty via an IDS ticket with any questions.

Retain the original customer pay invoice in your files; this documentation may be requested by BMW during the claim review process.

Note: A repair performed on a non-affected vehicle, or the diagnosis and repair of other unrelated issues do not qualify for reimbursement.

This claim submission for the prior customer-pay reimbursement, when it is submitted as outlined under Defect Code 85 99 00 45 NA, **will not close** the Open Safety Recall on the vehicle.

QUESTIONS REGARDING THIS BULLETIN

Technical inquiries	Contact the BMW Technical Support Group via TSARA
Warranty inquiries	Submit an IDS ticket to the Warranty Department
Parts inquiries	Submit an IDS ticket to the Motorrad Parts Department

Supporting Materials

[picture_as_pdf RECALL 22V-672 61 06 22 Replace Horn Mounting Screw.pdf](#)