

Safety Recall

Code: 69DZ



Subject Passenger Frontal Airbag

Release Date December 06, 2022

Affected Vehicles

Country	Beginning Model Year	Ending Model Year	Vehicle	Vehicle Count
USA	2022	2022	A3 SEDAN	3,681
USA	2022	2022	RS3 SEDAN	16
USA	2022	2022	S3 SEDAN	420
CAN	2022	2022	A3 SEDAN	1,117
CAN	2022	2022	S3 SEDAN	320

Check Campaigns/Actions screen in Elsa on the day of repair to verify that a VIN qualifies for repair under this action. Elsa is the only valid campaign inquiry & verification source.

- ✓ Campaign status must show "open."
- ✓ If Elsa shows other open action(s), inform your customer so that the work can also be completed at the same time the vehicle is in the workshop for this campaign.

Problem Description The front passenger airbag may have been folded incorrectly. An incorrectly folded airbag can tear, prohibiting it from deploying properly during a crash, and increasing the risk of an injury.

Corrective Action Replace the passenger frontal airbag.

Precautions Audi recommends avoiding use of the front passenger seat whenever possible until the recall work has been performed.

Code Visibility On or about September 7, 2022, the campaign code was applied to affected vehicles.

Owner Notification Owner notification will take place in December 2022. Owner letter examples are included in this bulletin for your reference.

Additional Information Please alert everyone in your dealership about this action, including Sales, Service, Parts and Accounting personnel. Contact Warranty if you have any questions.

IMPORTANT REMINDER ON VEHICLES AFFECTED BY SAFETY & COMPLIANCE RECALLS

New Vehicles in Dealer Inventory: It is a violation of federal law for a dealer to deliver a new motor vehicle or any new or used item of motor vehicle equipment (including a tire) covered by this notification under a sale or lease until the defect or noncompliance is remedied. By law, dealers must correct, prior to delivery for sale or lease, any vehicle that fails to comply with an applicable Federal Motor Vehicle Safety Standard or that contains a defect relating to motor vehicle safety.

Pre-Owned Vehicles in Dealer Inventory: Dealers should not deliver any pre-owned vehicles in their inventory which are involved in a safety or compliance recall until the defect has been remedied.

Dealers must ensure that every affected inventory vehicle has this campaign completed before delivery to consumers.

Parts Information

Parts Control Type: VIN to Order	If parts are needed to support a vehicle repair: <ul style="list-style-type: none"> • US Dealers - use AVA • CAN Dealers - contact the Parts Specialists via phone (800-767-6552), email (VWoAPartsSpecialists@vw.com), or chat/text with the VIN to order
---	--

Parts Control Type: Free Order	Parts will be managed by Free Order
---	-------------------------------------

Initial Allocation: YES	Dealers will be sent an initial allocation prior to customer notification. If no initial allocation was received, please reference the Repair Projection Tool (below) to view your potential VIN population.
--	--

Repair Projection Tool: (right click to open)	
--	---

Criteria	Quantity	Part Number	P.O.C. Part Description	Ordering Method
01	1	8Y1-880-204-D	AIRBAG	VIN to Order
	4	N 911-512-01	BOLT	Free Order

NOTE

The specified part numbers reflect the status at the start of this action. Interim updates made in ETKA can cause a listed part number to become unavailable. In this case, the new part number specified in ETKA should be used.

Claim Entry Instructions

The labor times listed here may differ from the labor operations and labor times listed in ELSA.

After campaign has been completed, enter claim as soon as possible to help prevent work from being duplicated elsewhere. Attach the Elsa screen print showing action open on the day of repair to the repair order.

If customer refused campaign work:

- ✓ U.S. dealers: Submit the request through Audi Warranty Online under the Campaigns/Update option.
- ✓ Canada dealers: Upload the repair order [signed by customer] to Audi WIN/Operations/Campaign Closure.

Service Number	69DZ		
Damage Code	0099		
Parts Vendor Code	002		
Claim Type	Sold vehicle: 7 10 Unsold vehicle: 7 90		
Causal Indicator	Mark AIRBAG* as causal part		
Vehicle Wash/Loaner	Do not claim wash/loaner under this action		
Criteria I.D.	01		
	LABOR		
	Labor Op	Time Units	Description
	6959 55 99	60	Replace passenger airbag
	2706 89 50	10	Connect battery charger (if necessary)
	0150 00 00	Time stated on diagnostic protocol	GFF Operations (if necessary)
	PARTS		
	Quantity	Part Number	Description
	1.00	8Y1880204D	AIRBAG*
	4.00	N 91151201	BOLT

Customer Letter Example (USA)

<MONTH YEAR>

<CUSTOMER NAME>

<CUSTOMER ADDRESS>

<CUSTOMER CITY STATE ZIPCODE>

This notice applies to your vehicle: <MODEL YEAR> <BRAND> <CARLINE>, <VIN>

NHTSA: 22V652

Subject: Safety Recall 69DZ – Passenger Frontal Airbag

Dear Audi Owner,

This notice is sent to you in accordance with the National Traffic and Motor Vehicle Safety Act. Audi has decided that a defect, which relates to motor vehicle safety, exists in certain 2022 model year Audi vehicles. Our records show that you are the owner of a vehicle affected by this action.

- What is the issue?** The front passenger airbag may have been folded incorrectly. An incorrectly folded airbag can tear, prohibiting it from deploying properly during a crash, and increasing the risk of an injury.
- What will we do?** To correct this defect, your authorized Audi dealer will replace the passenger frontal airbag. This work will take about an hour to complete and will be performed for you free of charge. Please keep in mind that your dealer may need additional time for the preparation of the repair, as well as to accommodate their daily workshop schedule.
- What should you do?** Please contact your authorized Audi dealer without delay to schedule this recall work. For your convenience, you can also visit www.audiusa.com and click on the “Find a Dealer” link to locate a dealer near you and schedule this service.
- Precautions you should take** Audi recommends avoiding use of the front passenger seat whenever possible until the recall work has been performed.
- Lease vehicles and address changes** If you are the lessor and registered owner of the vehicle identified in this action, the law requires you to forward this letter immediately via first-class mail to the lessee within ten (10) days of receipt. If you have changed your address or sold the vehicle, please fill out the enclosed prepaid Owner Reply card and mail it to us so we can update our records.
- Can we assist you further?** If your authorized Audi dealer fails or is unable to complete this work free of charge within a reasonable time, please contact Audi Customer Experience at 1-800-253-2834 or via our “Contact Us” page at www.audiusa.com.
- Checking your vehicle for open Recalls and Service Campaigns** To check your vehicle’s eligibility for repair under this or any other recall/service campaign, please visit the **Recall/Service Campaign Lookup** tool at www.audiusa.com and enter your Vehicle Identification Number (VIN).

If you still cannot obtain satisfaction, you may file a complaint with: The Administrator, National Highway Traffic Safety Administration, 1200 New Jersey Avenue, SE., Washington, DC 20590; or call the toll-free Vehicle Safety Hotline at 1-888-327-4236 (TTY: 1-800-424-9153); or go to <http://www.safercar.gov>.

We apologize for any inconvenience this matter may cause; however we are taking this action to help ensure your safety and continued satisfaction with your vehicle.

Sincerely,

Audi Customer Protection

Customer Letter Example (Canada)

<MONTH YEAR>

<CUSTOMER NAME>

<CUSTOMER ADDRESS>

<CUSTOMER CITY STATE ZIPCODE>

This notice applies to your vehicle: <MODEL YEAR> <BRAND> <CARLINE>, <VIN>

Transport Canada Recall: 2022-481

Subject: Safety Recall 69DZ – Passenger Frontal Airbag

Dear Audi Owner,

This notice is sent to you in accordance with the requirements of the *Motor Vehicle Safety Act*. This is to inform you that your vehicle may contain a defect that could affect the safety of a person. Our records show that you are the owner of a vehicle affected by this action.

What is the issue? The front passenger airbag may have been folded incorrectly. An incorrectly folded airbag can tear, prohibiting it from deploying properly during a crash, and increasing the risk of an injury.

What will we do? To correct this defect, your authorized Audi dealer will replace the passenger frontal airbag. This work will take about an hour to complete and will be performed for you free of charge. Please keep in mind that your dealer may need additional time for the preparation of the repair, as well as to accommodate their daily workshop schedule.

What should you do? Please contact your authorized Audi dealer without delay to schedule this recall work.

Precautions you should take Audi recommends avoiding use of the front passenger seat whenever possible until the recall work has been performed.

Lease vehicles and address changes If you are the lessor and registered owner of the vehicle identified in this letter, you shall forward this letter (and any subsequent notice, if applicable) to the lessee within ten (10) days of receipt. If you have changed your address or sold the vehicle identified in this letter, please fill out the enclosed prepaid Owner Reply Card and mail it to us so we can update our records.

Can we assist you further? If your authorized Audi dealer fails or is unable to complete this work free of charge within a reasonable time, please contact Audi Customer Relations Monday through Friday from 8AM to 8PM EST at 1-800-822-2834 or via our “Contact Audi Canada” page at www.audi.ca.

We apologize for any inconvenience this matter may cause; however we are taking this action to help ensure your safety and continued satisfaction with your vehicle.

Sincerely,

Audi Customer Protection

Repair Overview

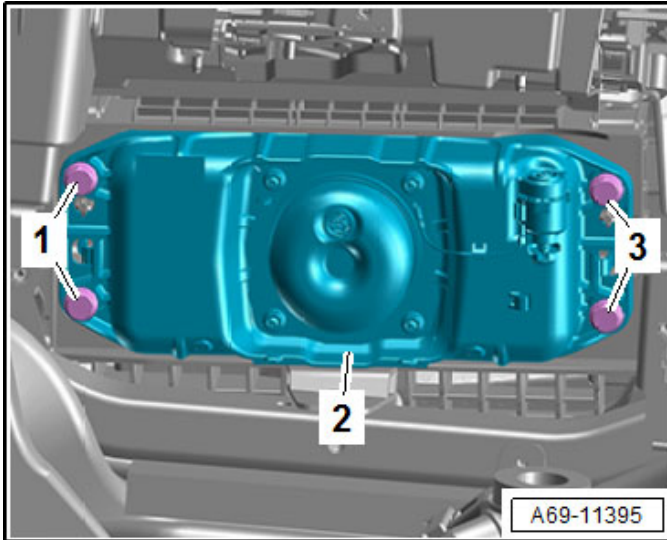

- Replace passenger frontal airbag.

NOTE

- These repair instructions may differ from the labor operations and labor times listed in ELSA.
- Damages resulting from improper repair or failure to follow these work instructions are the dealer's responsibility and are not eligible for reimbursement under this action.
- This procedure must be read in its entirety prior to performing the repair.
- Due to variations in vehicle equipment and options, the steps/illustrations in this work procedure may not identically match all affected vehicles.
- Diagnosis and repair of pre-existing conditions in the vehicle are not covered under this action.
- When working during extreme temperatures, it is recommended that the vehicle be allowed to acclimate inside the shop to avoid temperature-related component damage/breakage.

Repair Instruction

Section A - Check for Previous Repair

Applicable criteria ID(s)	Campaign/Action Status
01 ← 2	Open ← 1

EXAMPLE

Campaign/Action	Start	Designation
→ 3	2015-11-10	W-SERV_ACT -
	2018-12-13	RECALL -
	2017-05-16	A-RECALL -

EXAMPLE

- Enter the VIN in Elsa and proceed to the “Campaign/Action” screen.

TIP

On the date of repair, print this screen and keep a copy with the repair order.

- Confirm the Campaign/Action is open <arrow 1>. If the status is closed, no further work is required.
- Note the Applicable Criteria ID <arrow 2> for use in determining the correct work to be done and corresponding parts associated.

CRITICAL REPAIR STEP

 **STOP!** 

If multiple software update Campaign/Actions are open, they must be performed in order of the Start date <arrow 3>. The oldest should be performed first.

- **All Safety Recalls must be completed prior to completing this campaign.**
- **Proceed to Section B.**

Section B – Repair Procedure

⚠ WARNING

Risk of injury. Refer to “Warning and Safety Precautions”, found in **Appendix A** at the end of this document.

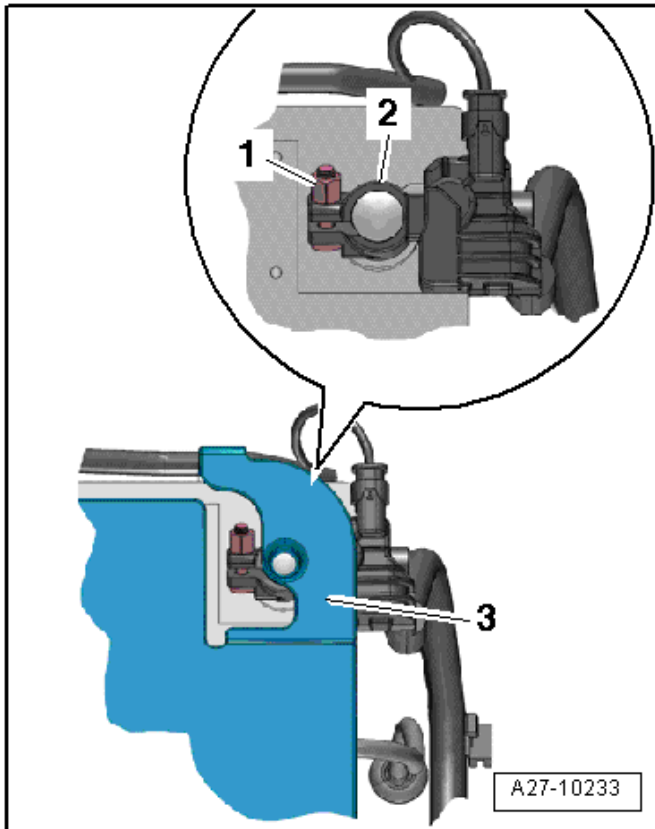

Disconnect the 12V battery:

⚠ WARNING

Accident risk. When working on pyrotechnic components (such as airbags and belt tensioners), the battery must be disconnected with the ignition switched **ON**.

- Turn the ignition **ON**.
- Access the 12V battery.
- Loosen the nut <1>.
- Remove and isolate the battery ground cable terminal from the battery pole.

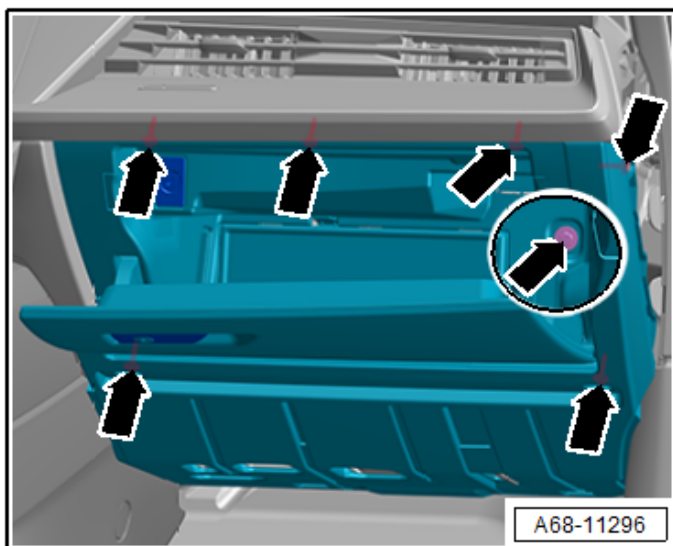

Remove glove compartment:

- See ELSA Repair Manual: *Repair manual > Body > Body Interior > 68 Interior Equipment > Storage Compartments and Covers > Glove Compartment, Removing and Installing*

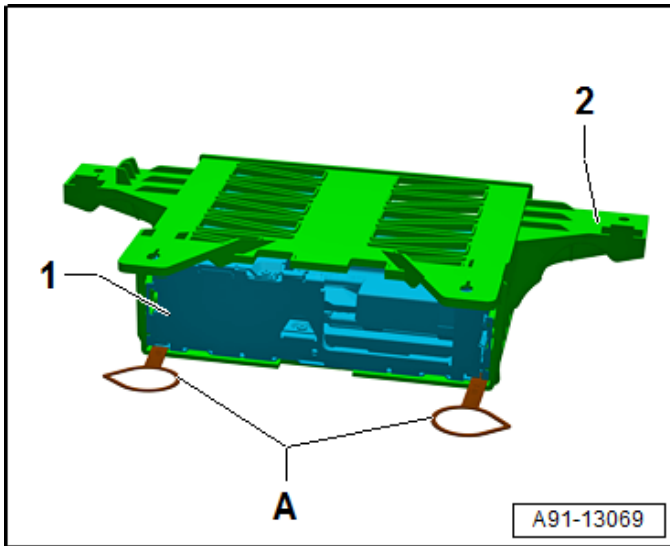

Remove the Information Electronics Control Module 1 -J794-:

- See ELSA Repair Manual: *Repair manual > Electrical System > Communication > 91 Communication > Infotainment System > Information Electronics Control Module 1 J794, Removing and Installing*
- The -J794- can hang by its wires for this procedure.

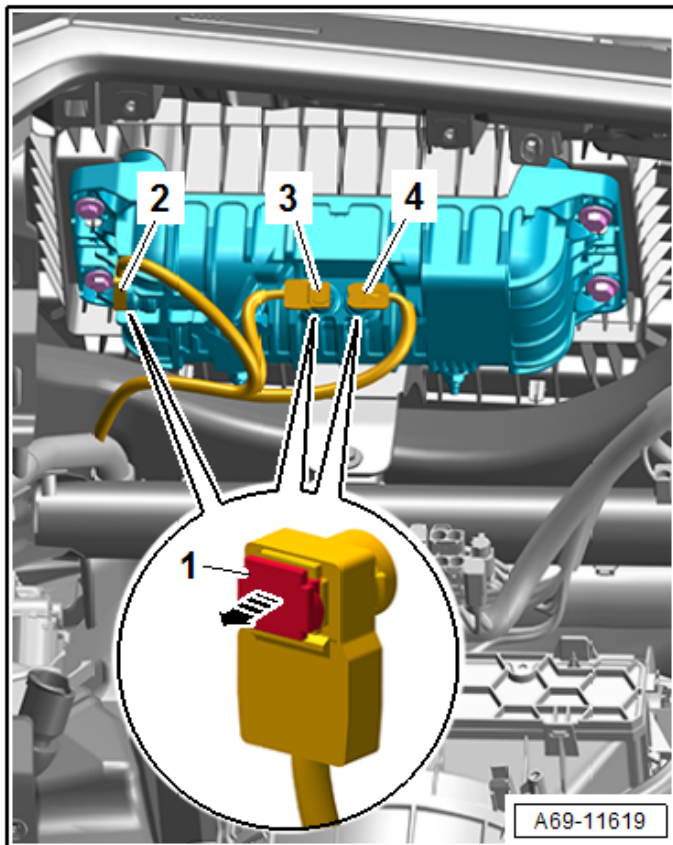

Replacing passenger frontal airbag:

⚠ WARNING

Before handling pyrotechnic components (for example, disconnecting the connector), the person handling it must “discharge static electricity”. This can be done by touching the door striker, for example.

- Release the connector lock <1> with a small flat-head screwdriver <arrow>.
- Disconnect the connectors <2, 3 and 4> from the Front Passenger Airbag Igniters.

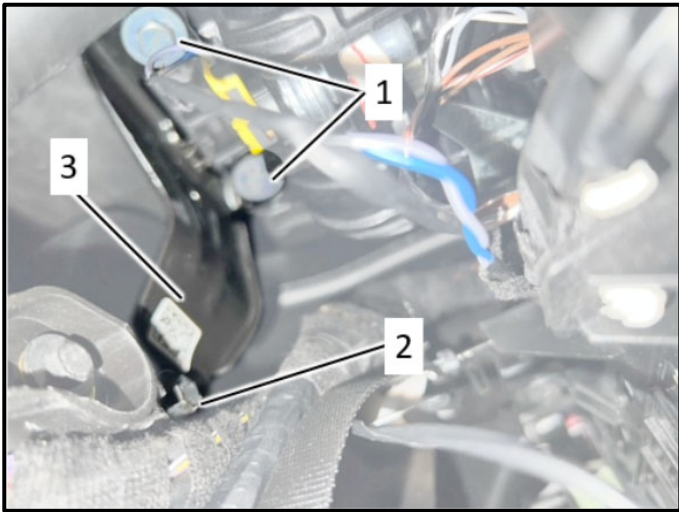

- Remove bolts <1> and <2>.
- Remove bracket <3>.

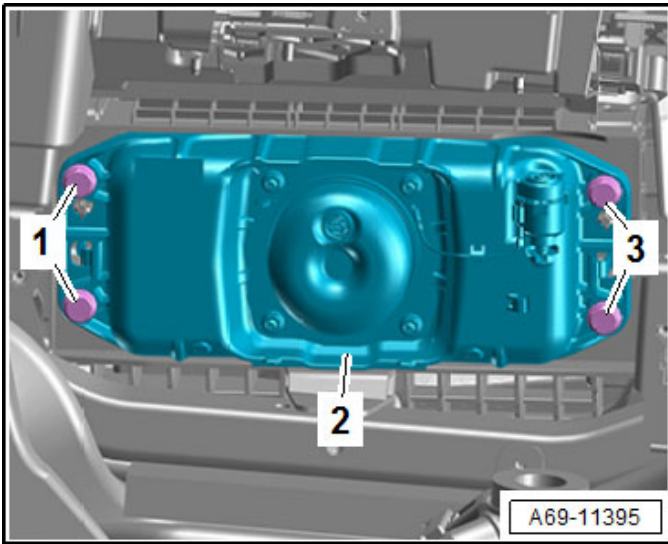

⚠ WARNING

Secure the airbag unit from falling.

- Remove the bolts <1 and 3>.
- Release the locking tabs.
- Remove the airbag <2> downward.

⚠ WARNING

Set the airbag down so the airbag fabric faces upward.

- Installation is the reverse order of removal.
- Torque new bolts <1 and 3> to 8 Nm.

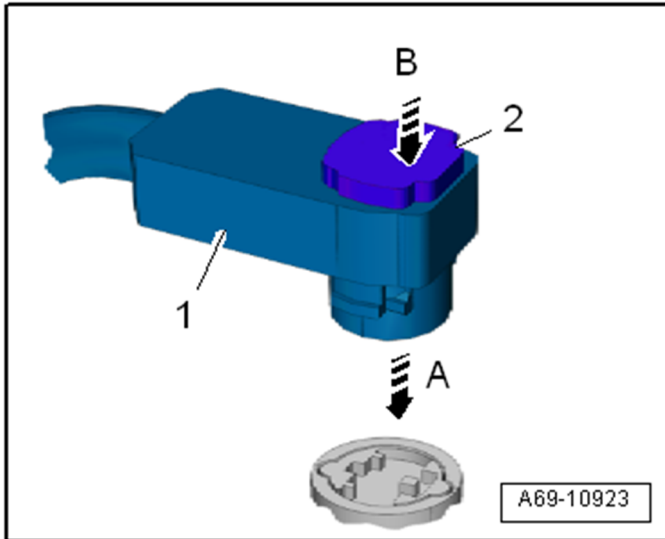

- Connect and lock electrical connectors.
- Ensure the locks audibly engage.
- Ensure the wires do not get caught.

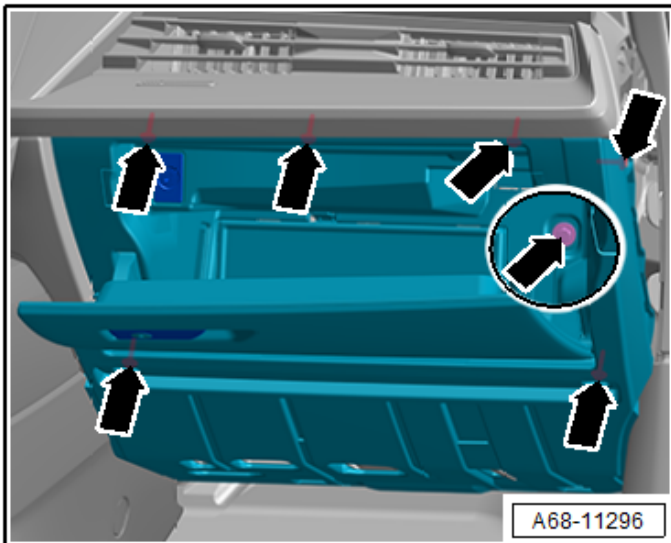

Reassemble vehicle:

- Reassembly is the reverse order of removal.
- Torque -J794- bracket fasteners to 3 Nm.
- Torque glove compartment bolts to 3 Nm.

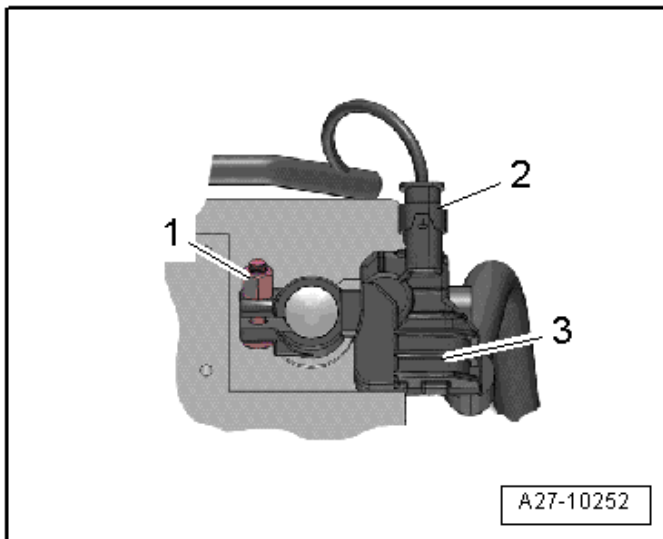

Reconnect 12V battery:

⚠ WARNING

Ignition must be **ON** when connecting battery. If pyrotechnic components (e.g. airbag, belt tensioner) are not repaired correctly, they may deploy unintentionally after connecting battery. There must not be anyone inside the vehicle when connecting the battery.

- Disconnect the connector <2> from the Battery Monitoring Control Module -J367- <3>.
- Attach the battery ground cable clamp by hand to the battery negative terminal and torque the nut <1> to 6 Nm.
- Reconnect the connector to the Battery Monitoring Control Module -J367-.
- Activate the convenience one-touch open/close functions.
- Check the DTC memories of all the control units and erase under-voltage faults if necessary.

Proceed to Section C

Section C – Campaign Completion Stamp

I certify that this campaign
has been performed in strict
accordance with the applicable
Audi repair procedure.

SAGA Code: _____
Technician: _____
Date: _____

Item#: AUD4927ENG

-OR-

Je certifie que cette
campagne de rappel a été
exécutée suivant les strictes
directives de réparation
d'Audi

Code de SAGA: _____
Technicien: _____
Date: _____

Item # AUD4927FRE

- Once the campaign has been completed, the technician should stamp the repair order.
- Stamps are available for ordering through the Compliance Label Ordering Portal.
- **Proceed to Section D**

Section D - Parts Return/Disposal

Properly store (retain), destroy or dispose of removed parts in accordance with all state/province and local requirements, unless otherwise indicated and/or requested through the Warranty Parts Portal (WPP) for U.S. and the Part Destruction and Core Disposition Report for Canada.

Appendix A – Warning and Safety Precautions

WARNING

General Safety Precautions when Working with Pyrotechnic Components:

- Pyrotechnic components always contain propellant that generates a gas during combustion. In some components, there is also a supply of pressurized gas to ensure this gas is generated
- This pressurized gas is stored under high pressure in a compressed gas container. Pyrotechnic components are triggered by electrical/mechanical igniters.
- Only trained personnel should perform testing, assembly and servicing work. Airbags do not have a replacement interval.
- Never check with test lamps, voltmeter or ohmmeters.
- Only check pyrotechnic components when they are installed in the vehicle using vehicle diagnosis, testing and information systems approved by the manufacturer.
- When working on pyrotechnic components and the airbag control module, disconnect the battery ground strap while the ignition is switched on. Then cover the negative terminal.
- Wait 10 seconds after disconnecting the battery.
- The ignition must be SWITCHED ON when connecting the battery. There should not be anyone inside the vehicle when doing this.
- Exception: vehicles with batteries in the passenger compartment. In this case, stay outside the range of the airbags and seat belts.
- Wash your hands after touching ignited pyrotechnic components from the restraint system.
- Do not open or repair pyrotechnic components. Use only new components to reduce the risk of injury.
- Do not install pyrotechnic components that have fallen onto a hard surface or show signs of damage.
- Discharge static electricity before handling pyrotechnic components, for example before disconnecting the electrical connector. This can be done by touching grounded metal objects such as the door striker pin.
- Install pyrotechnic components immediately after removing them from their transport packaging. If you must stop working, store the pyrotechnic component in its original transport packaging.
- Do not leave pyrotechnic components lying in the open unattended.
- Do not treat pyrotechnic components with grease, cleaning solutions or similar products.
- Do not expose pyrotechnic components to temperatures above 100 °C, even for brief periods of time.
- People in the immediate vicinity of the workplace must be protected from possible noise and projectiles.
- Pyrotechnic components can trigger unintentionally.
- In the event of deployment:
 - Single-stage inflators: allow airbag to cool down completely. Wait at least 10 minutes before handling.
 - Two-stage inflators: wait for second airbag ignition. Allow airbag to cool down completely. Wait at least 10 minutes before handling.