 <b>HYUNDAI</b> <b>Technical Service Bulletin</b>	GROUP <b>RECALL</b>	NUMBER <b>23-01-044H</b>
	DATE <b>MAY 2023</b>	MODEL(S) <b>PALISADE (LX2)</b>
<b>SUBJECT:</b> TRAILER TOW HITCH HARNESS INSPECTION AND 4 PINS PIGTAIL EXTENSION WIRE & HARNESS/FUSE REPLACEMENT (RECALL 235)		

*This TSB supersedes 22-01-070H to provide the service procedure (pigtail/fuse replacement or harness replacement and fuse replacement) for the Genuine Hyundai Accessory trailer tow hitch wire harness and add additional op codes and warranty information.*

**\* IMPORTANT**

Vehicle repairs related to safety recalls are critically important and must be performed properly in accordance with TSB procedures. Review this bulletin in its entirety prior to beginning any repair work.

As required by federal law, dealers must not deliver new vehicles for sale or for lease to customers until all open recalls have been performed. Dealers must also perform all open recalls on used vehicles, demo, and rental vehicles prior to placing them into customer use and whenever an affected vehicle is in the shop for any maintenance or repair.

Access the “Vehicle Information” screen (VIS) via WEBDCS to identify open recalls.

**Description:** Certain 2020 - 2022 Palisade (LX2) vehicles may be equipped with a Genuine Hyundai Accessory tow hitch assembly supplied by and available for purchase through Hyundai as a Port Installed Option (PIO), as a Dealer Installed Option (DIO) or through over the counter part sale. Certain tow hitch harness modules may develop an electrical short circuit. An electrical short could increase the risk of a tow hitch harness module fire while driving or while the vehicle is parked with the ignition off.

This bulletin provides the inspection procedure for the Genuine Hyundai Accessory trailer tow hitch and wire harness. The Extension Wire Harness Repair and Fuse Replacement, and Extension Harness Assembly and Fuse Replacement procedures are provided for vehicles equipped with the Genuine Hyundai Accessory trailer tow hitch and wire harness.

**STUI**



**This TSB includes STUI picture(s) as a requirement.** Where indicated, please include the last 6 digits of the VIN and date of inspection/repair on a piece of paper. Ensure the VIN and date of inspection/repair are clearly visible. Finally, please ensure all captured pictures are completed according to the steps in this TSB and uploaded to STUI. All claims submitted that have illegible, incomplete, missing, or incorrect picture(s) are subject to debit.

**Applicable Vehicles:** Certain 2020 - 2022MY Palisade (LX2) produced 04/10/2019 – 05/30/2022

Circulate To: General Manager, Service Manager, Sales Manager, Parts Manager, Warranty Manager, Service Advisors, Technicians, Body Shop Manager, Fleet Repair

**SUBJECT: TRAILER TOW HITCH HARNESS INSPECTION AND 4 PINS PIGTAIL HARNESS/FUSE REPLACEMENT (RECALL 235)**

**Parts Information:**

MODEL	PART NAME	PART NUMBER	IMAGE
PALISADE (LX2)	EXTENSION WIRE KIT	S8F67 AC900QQH	
PALISADE (LX2)	FUSE ASSY-TRAILER	18790 04930QQH	  <p>FUSE                      STICKER</p>
PALISADE (LX2)	EXTENSION HARNESS ASSY KIT	S8F67 ACB00	

**SUBJECT:****TRAILER TOW HITCH HARNESS INSPECTION AND 4 PINS PIGTAIL  
EXTENSION WIRE & HARNESS/FUSE REPLACEMENT (RECALL 235)****SST Information:**

DESCRIPTION	IMAGE
4 Pins Mini-Tester	
Heat Gun	
Insulated Terminal Crimping Tool 3005CR	
Multimeter Test Tool (Set to read current in mA)	

**NOTE:** Other crimp tools can be used (e.g. general crimping tool below), as long as it is intended for insulated wire terminals (nylon terminal).

General Crimping Tool	
-----------------------	--

**SUBJECT: TRAILER TOW HITCH HARNESS INSPECTION AND 4 PINS PIGTAIL HARNESS/FUSE REPLACEMENT (RECALL 235)**

**Warranty Information:**

MODEL	OP. CODE	OPERATION	OP. TIME	CAUSAL PART	NATURE	CAUSE
PALISADE (LX2)	RC235HYU	TRAILER TOW HITCH INSPECTION – NO HARNESS	0.2 M/H	S8F67-AC401	I11	ZZ3
	RC235HA1	INSPECTION, EXTENSION WIRE HARNESS REPAIR AND FUSE REPLACEMENT	0.7 M/H	S8F67-AC401	I11	ZZ3
	RC235HA2	INSPECTION, EXTENSION HARNESS ASSEMBLY AND FUSE REPLACEMENT	0.4 M/H	S8F67-AC401	I11	ZZ3

**NOTE 1:** Submit Claim on Campaign Claim Entry Screen.

**NOTE 2: Vehicle not equipped with Genuine Hyundai Accessory trailer tow hitch and wire harness installed** - Claim must include a STUI picture of the rear center lower bumper clearly visible along with a piece of paper displaying the last 6 digits of the VIN and date of the inspection. **If not included, claim will be subject to debit.**

**NOTE 3: Vehicle equipped with Genuine Hyundai Accessory trailer tow hitch and wire harness installed** - Claim must include three (3) STUI pictures of the following: (1) wire splicing of the replaced Genuine Hyundai Accessory trailer tow harness pigtail or removed harness assembly, (2) Multimeter reading result, and (3) newly installed 15A fuse, along with a piece of paper displaying the last 6 digits of the VIN and date of the repair for each one. **If not included, claim will be subject to debit.**

**NOTE 4:** The incident parts are subject to callback through the normal Warranty Technical Center (WTC) parts return process. **Claim is subject to debit if the part is not returned.**

**SUBJECT:****TRAILER TOW HITCH HARNESS INSPECTION AND 4 PINS PIGTAIL EXTENSION WIRE & HARNESS/FUSE REPLACEMENT (RECALL 235)****Service Procedure:**

Refer to the link below for guided video information:

[Hyundai Service Learning - Recall 235 Service Procedure](#)

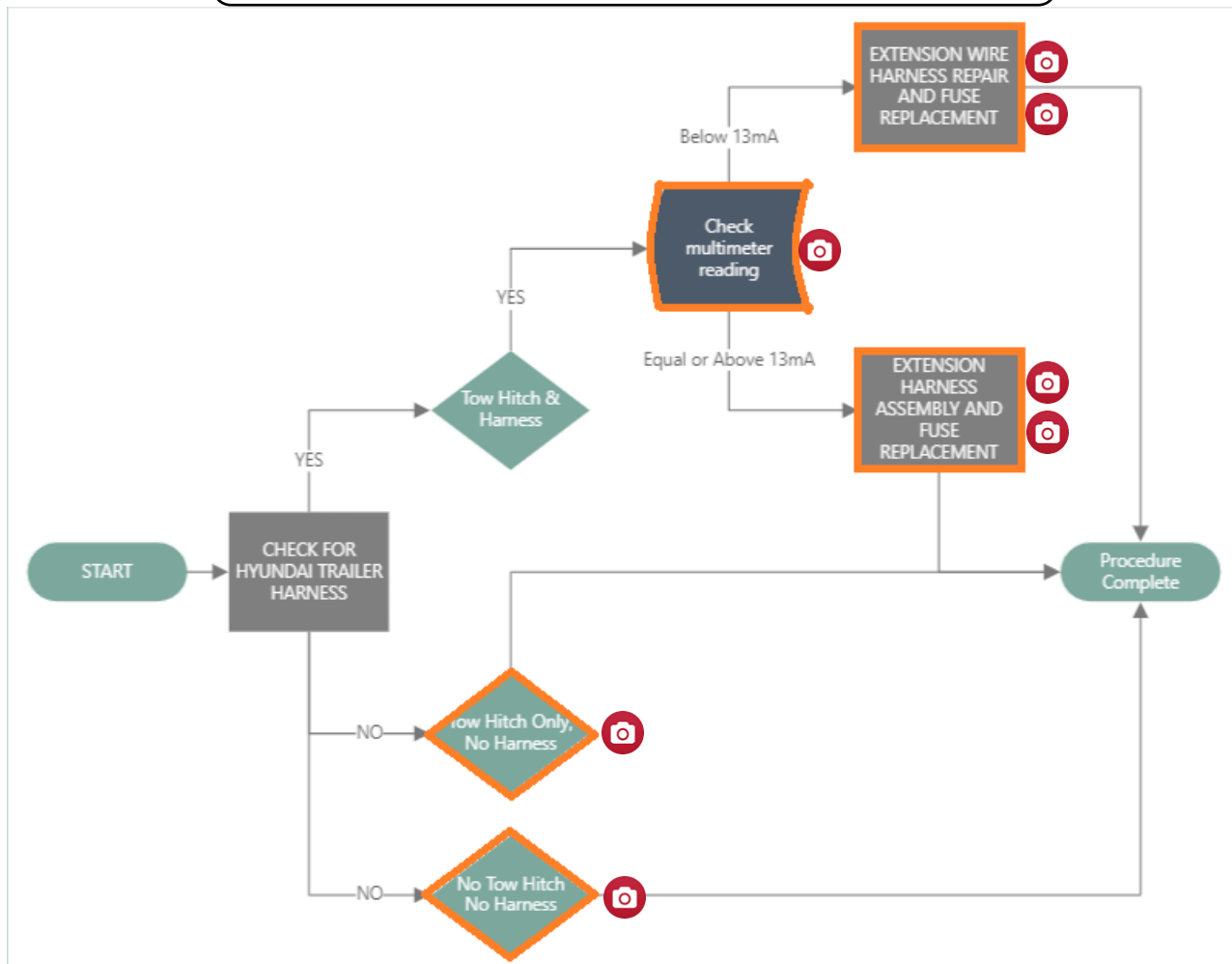
**TRAILER TOW HITCH INSPECTION**

1. Visually inspect the center rear lower bumper for the following:

- Genuine Hyundai Accessory trailer tow hitch and wire harness installed.
- Genuine Hyundai Accessory trailer tow hitch installed, but no visible harness connection installed.
- No trailer tow hitch installed



1A. If the vehicle is equipped with a Genuine Hyundai Accessory trailer tow hitch and wire harness, please refer to "MULTIMETER READING TO DETERMINE HARNESS REPAIR" on page 7.



**SUBJECT: TRAILER TOW HITCH HARNESS INSPECTION AND 4 PINS PIGTAIL HARNESS/FUSE REPLACEMENT (RECALL 235)**

- 1B. If the vehicle is not equipped with a Genuine Hyundai Accessory trailer tow hitch, then proceed to Step 2 below to complete the procedure.



- 1C. If the vehicle is equipped with a Genuine Hyundai Accessory trailer tow hitch, but there is no visible wire harness installed, then proceed to Step 2 to complete the procedure.



2. Write the last six digits of the VIN and date of repair onto a piece of paper and place it near the center of the rear bumper.

**STUI**



**Using STUI, take a picture of the rear center lower bumper. Upload the photo to STUI.**



Example to the right is a picture of a vehicle not equipped with the Genuine Hyundai Accessory trailer tow hitch.

3. Procedure complete.

**SUBJECT:**

**TRAILER TOW HITCH HARNESS INSPECTION AND 4 PINS PIGTAIL  
EXTENSION WIRE & HARNESS/FUSE REPLACEMENT (RECALL 235)**

**MULTIMETER READING TO DETERMINE HARNESS REPAIR**

**NOTE:** This procedure only applies to vehicles equipped with Genuine Hyundai Accessory trailer tow hitch and wire harness.

1. Align the vehicle to the vehicle lift position. Do not lift the vehicle.
2. Open the hood and remove the 40A trailer fuse inside the junction box.



**Information**

If there is no 40A trailer fuse, it was previously removed during the campaign P31.

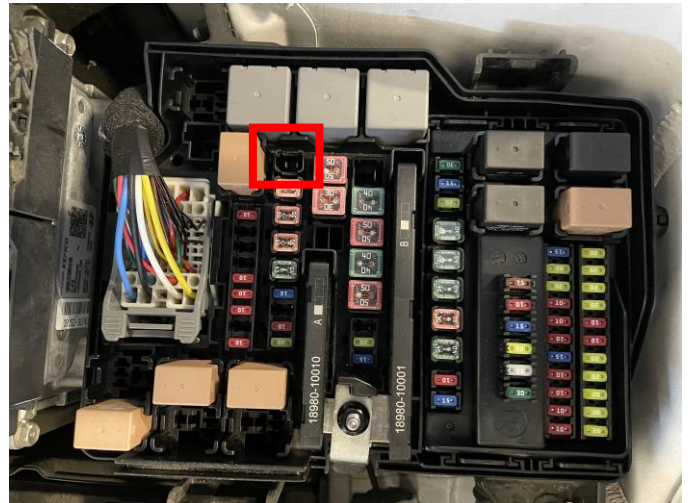
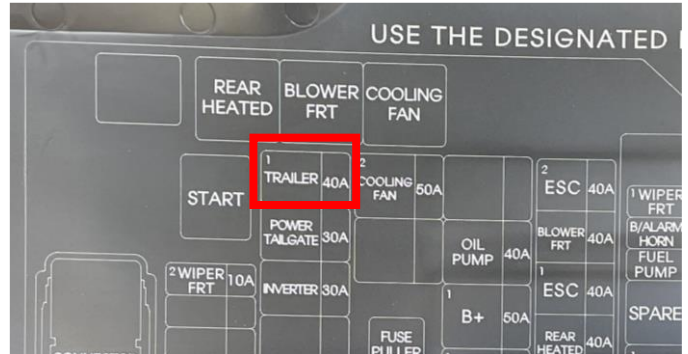

3. Measure both terminals where the fuse was with a multimeter probe.



**Information**

Vehicle should be OFF, with key removed.



**SUBJECT: TRAILER TOW HITCH HARNESS INSPECTION AND 4 PINS PIGTAIL HARNESS/FUSE REPLACEMENT (RECALL 235)**

4. Check whether the multimeter is reading above or below 13mA.

If reading is **below 13mA**, proceed to step 5 to perform wire harness repair with extension wire kit, install an updated fuse, and fuse label.

If reading is **equal to or above 13mA**, the accessory harness assembly must be removed and replaced. An updated fuse must also be installed with a new fuse label.

Proceed to page 17 for harness assembly removal and replacement procedure.

**STUI**



**Using STUI, take a picture of the multimeter reading with the last 6 digits of the VIN and date of the repair on a piece of paper. Ensure picture is clear before taking. Upload the photo to STUI.**

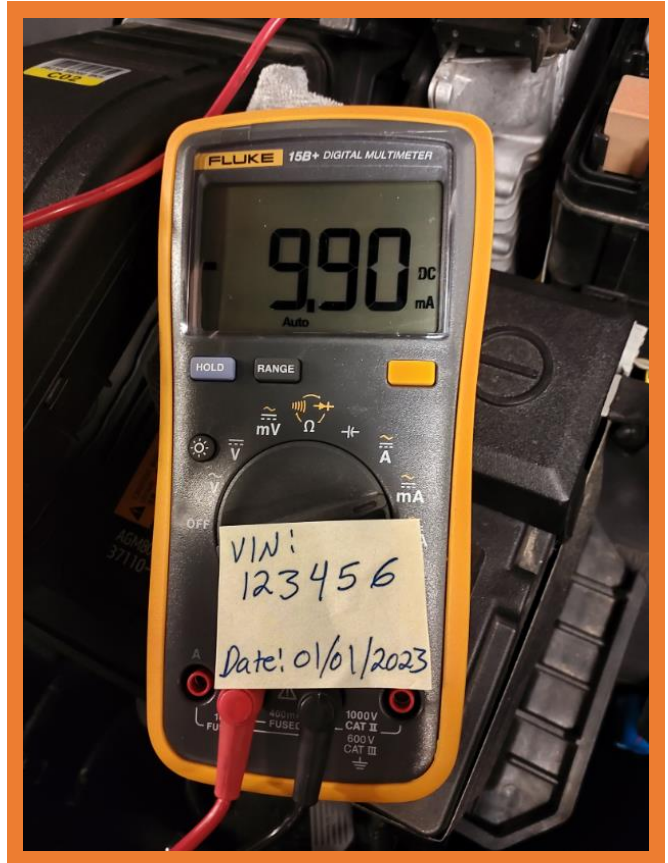

**WIRE HARNESS REPAIR (EXTENSION WIRE KIT), FUSE REPLACEMENT, AND FUSE LABEL ATTACHMENT**

5. A) Record any pre-set radio stations, if applicable.
- B) Open the vehicle's hood.
- C) Remove the cap from the negative (-) battery cable, if applicable.
- D) Disconnect and isolate the vehicle's negative (-) battery cable.

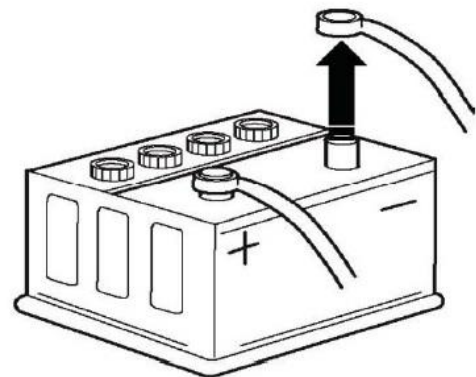



**SUBJECT:**

**TRAILER TOW HITCH HARNESS INSPECTION AND 4 PINS PIGTAIL  
EXTENSION WIRE & HARNESS/FUSE REPLACEMENT (RECALL 235)**

6. Lift vehicle.

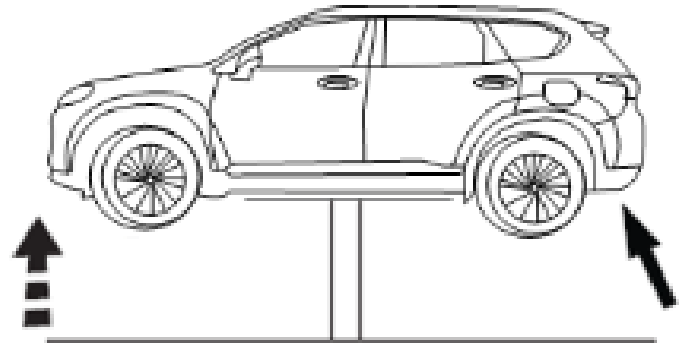

7. Remove rear bumper under cover.

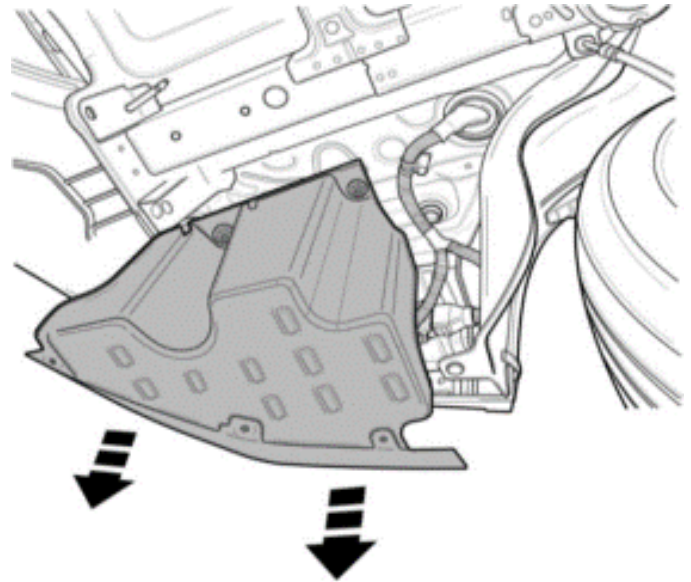

8. Release the 4-Pin connector fixing bolt.

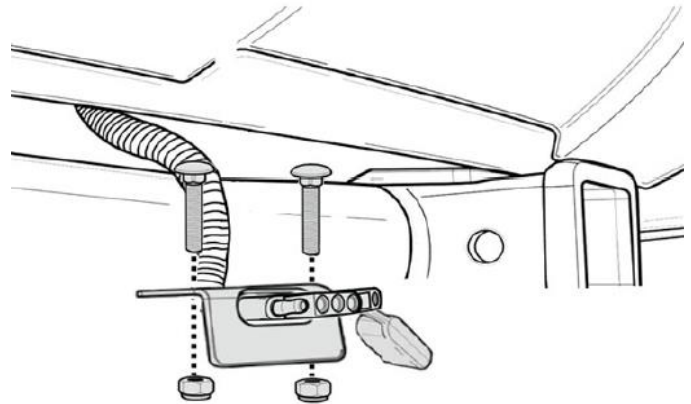

**SUBJECT:****TRAILER TOW HITCH HARNESS INSPECTION AND 4 PINS PIGTAIL HARNESS/FUSE REPLACEMENT (RECALL 235)**

9. Cut one cable tie and separate the 4-Pin connector.



10. Pull out the 4-Pin connector to mark where to cut.



11. Cut the harness to match the length of the extension wire.



**SUBJECT:** TRAILER TOW HITCH HARNESS INSPECTION AND 4 PINS PIGTAIL  
EXTENSION WIRE & HARNESS/FUSE REPLACEMENT (RECALL 235)

12. Cut off about 10 cm of the corrugated tube and pull out the wires.



13. Strip the sheath of the wires. Expose 8-10mm of the wiring.

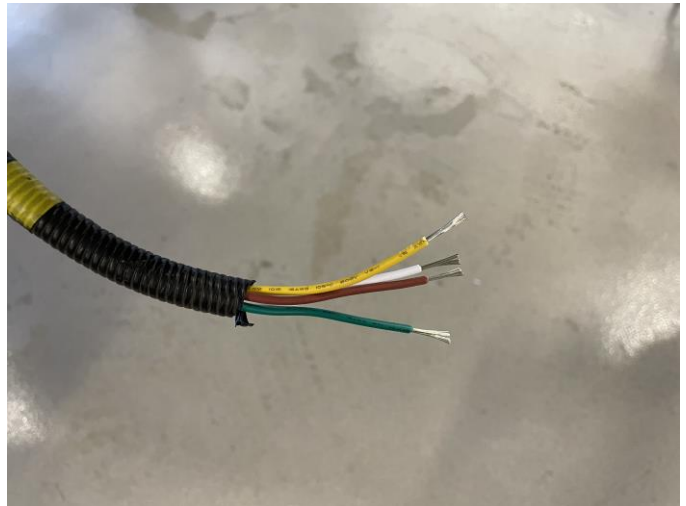

14. Match the wires by color and crimp them.



**SUBJECT: TRAILER TOW HITCH HARNESS INSPECTION AND 4 PINS PIGTAIL HARNESS/FUSE REPLACEMENT (RECALL 235)**

15. Blow hot air onto the butt splice / quick connector until it shrinks. (350°C/650°F).



- 16.

**STUI**



Using STUI, take a picture of the wire spliced with the last 6 digits of the VIN and date of the repair on a piece of paper. Upload the photo to STUI.



17. Raise the corrugated tube up to the mark and seal both ends with electrical tape.



**SUBJECT:** TRAILER TOW HITCH HARNESS INSPECTION AND 4 PINS PIGTAIL EXTENSION WIRE & HARNESS/FUSE REPLACEMENT (RECALL 235)

18. Insert the 4-Pin connector into the bracket and tighten the bracket bolts.

**4-Pin connector tightening nut:**

7.8 – 9.8 Nm (0.8 – 1.0 kgf.m, 5.2 – 8.7 lb-ft)



19. Fasten and secure harness with cable ties.

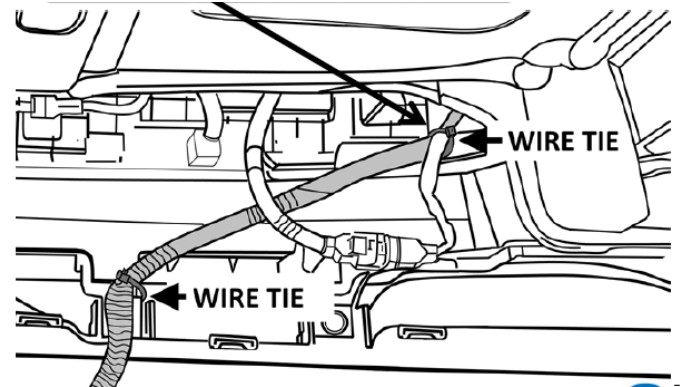

20. Reinstall rear bumper under cover.

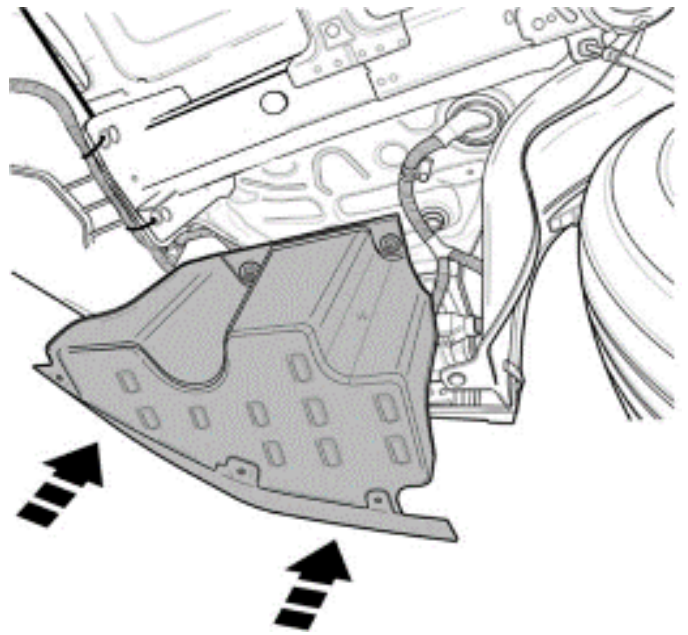

**SUBJECT:** TRAILER TOW HITCH HARNESS INSPECTION AND 4 PINS PIGTAIL HARNESS/FUSE REPLACEMENT (RECALL 235)

21. Lower vehicle.

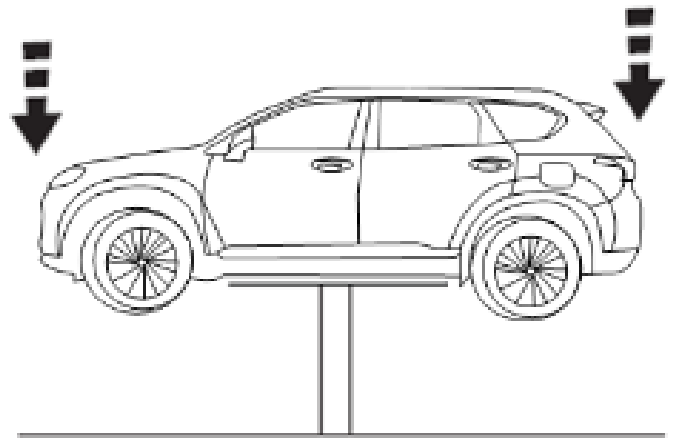

22. A) Reconnect the vehicle's negative (-) battery cable.

**Torque to:**  
**5.0 ~ 6.0 Nm (0.5 ~ 0.6 kgf.m, 45 ~ 52 lb-in).**

B) Reinstall the cap from the negative (-) battery cable, if applicable.

C) Close the vehicle's hood.

D) Reprogram any pre-set radio stations, if applicable.

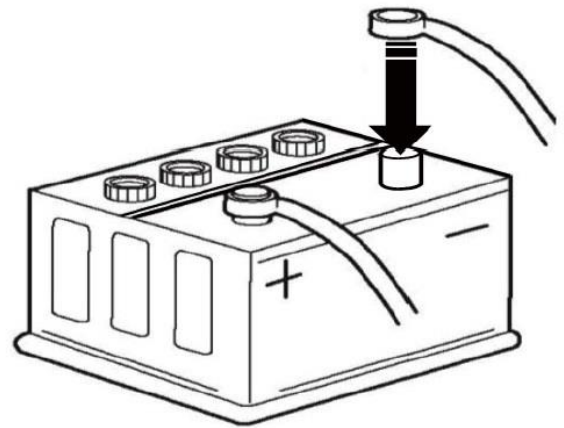

23. Replace the trailer fuse (same as step 2 on page 7) and attach the 15A sticker to the junction box cover.

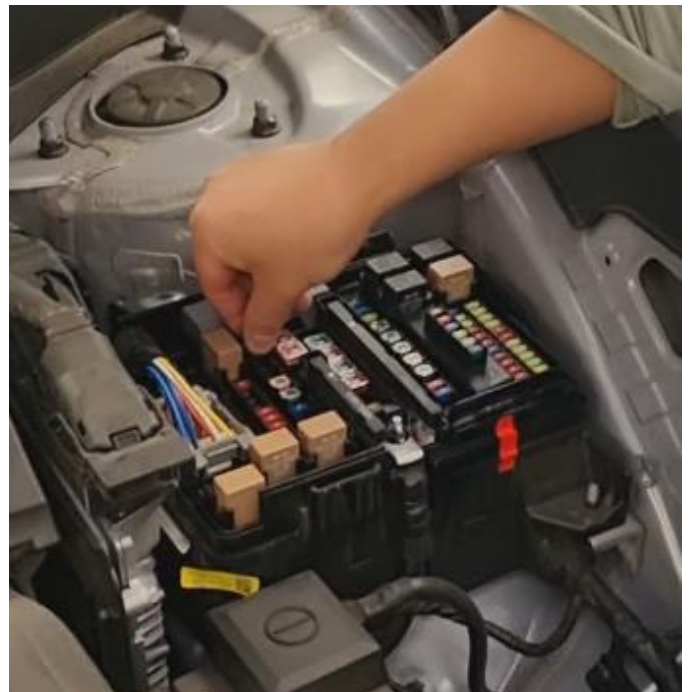

**SUBJECT:**

**TRAILER TOW HITCH HARNESS INSPECTION AND 4 PINS PIGTAIL  
EXTENSION WIRE & HARNESS/FUSE REPLACEMENT (RECALL 235)**

24. Write the last six digits of the VIN and date of repair onto a piece of paper and place it near the replaced 15A fuse in the engine fuse box.

**STUI**



**Using STUI, take a picture of the engine fuse box with the last 6 digits of the VIN and date of the repair on a piece of paper. Ensure picture is clear before taking. Upload the photo to STUI.**



25. Connect the 4 pins mini-tester to the trailer hitch 4 pins connector.

A second person is required to confirm the 4 pins mini-tester validation.

Perform the validation following the table on the next page.



**4 Pins Mini-Tester Light Validation**



**NOTE: The three lights are TAIL, LT, and RT**

Activate From Vehicle	Light Output From Mini-Tester	
	Engine Off	Engine On
Right Turn Signal ON	No light	<b>RT</b> light flashes
Left Turn Signal ON	No light	<b>LT</b> light flashes
Hazard ON	<b>LT</b> and <b>RT</b> light flashes	<b>LT</b> and <b>RT</b> light flashes
Brake Depressed	<b>LT</b> and <b>RT</b> light constantly ON	<b>LT</b> and <b>RT</b> light constantly ON
Turn Light Switch to ON position	<b>TAIL</b> light constantly ON	<b>TAIL</b> light constantly ON
Turn Light Switch to ON position and Hazard ON	<b>TAIL</b> light constantly ON and <b>LT</b> and <b>RT</b> light flashes	<b>TAIL</b> light constantly ON and <b>LT</b> and <b>RT</b> light flashes
Turn Light Switch to ON position and Brake Depressed	<b>TAIL</b> light constantly ON and <b>LT</b> and <b>RT</b> light constantly ON	<b>TAIL</b> light constantly ON and <b>LT</b> and <b>RT</b> light constantly ON

26. Procedure complete.



**SUBJECT:**

**TRAILER TOW HITCH HARNESS INSPECTION AND 4 PINS PIGTAIL  
EXTENSION WIRE & HARNESS/FUSE REPLACEMENT (RECALL 235)**

**EXTENSION HARNESS ASSEMBLY, FUSE REPLACEMENT, AND FUSE LABEL ATTACHMENT**

1. A) Record any pre-set radio stations, if applicable.

B) Open the vehicle's hood.

C) Remove the cap from the negative (-) battery cable, if applicable.

D) Disconnect and isolate the vehicle's negative (-) battery cable.

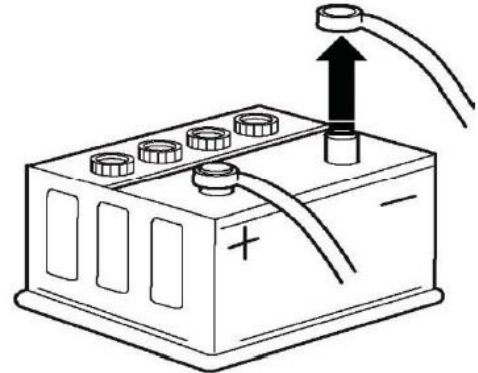

2. Lift vehicle.

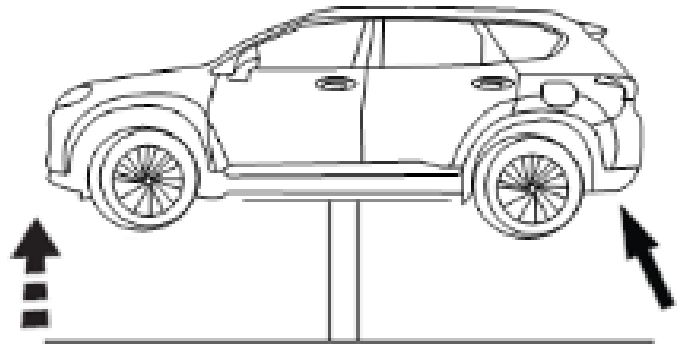

3. Remove rear bumper under cover.

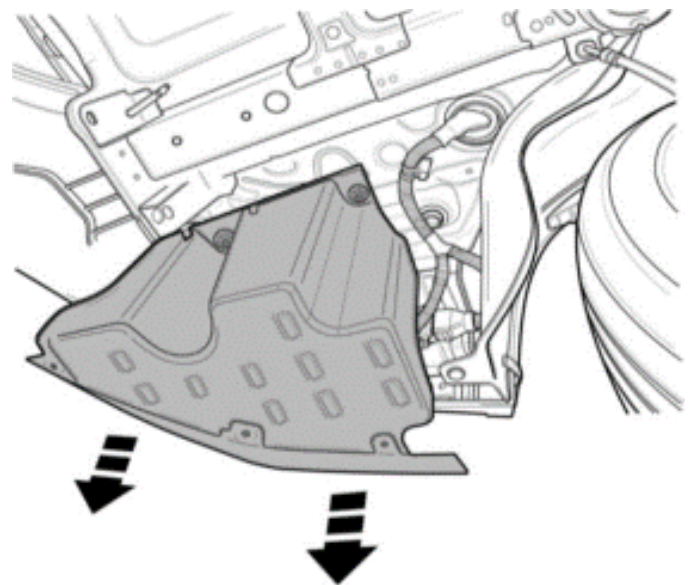

**SUBJECT:** TRAILER TOW HITCH HARNESS INSPECTION AND 4 PINS PIGTAIL HARNESS/FUSE REPLACEMENT (RECALL 235)

4. Release the 4-pin connector fixing bolt.

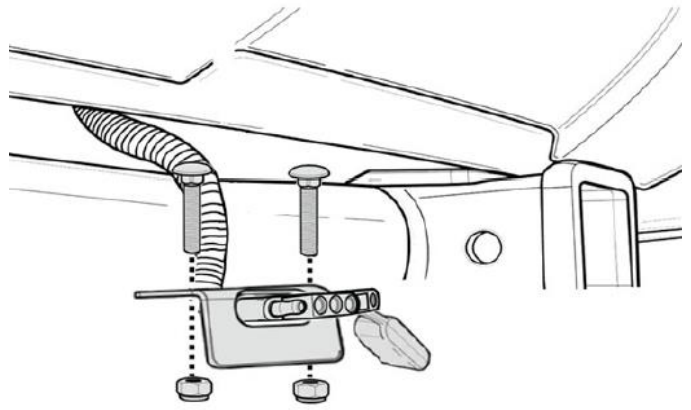

5. Cut one cable tie and separate the 4-Pin connector.



6. Locate the factory 12-Pin harness connector on the driver's side rear quarter panel area.

NOTE: Disconnect and remove the original 12-pin harness with connector from the vehicle factory connector.



**SUBJECT:** TRAILER TOW HITCH HARNESS INSPECTION AND 4 PINS PIGTAIL EXTENSION WIRE & HARNESS/FUSE REPLACEMENT (RECALL 235)

7. Connect the new tow hitch harness 12-Pin connector to the vehicle factory connector.



8. Secure the module to the vehicle factory harness, as shown, by passing one (1) cable tie through the side tabs of the module, one (1) cable tie through the hole at the end of the module and one (1) cable tie at the base of the module. Trim excess cable tie material.

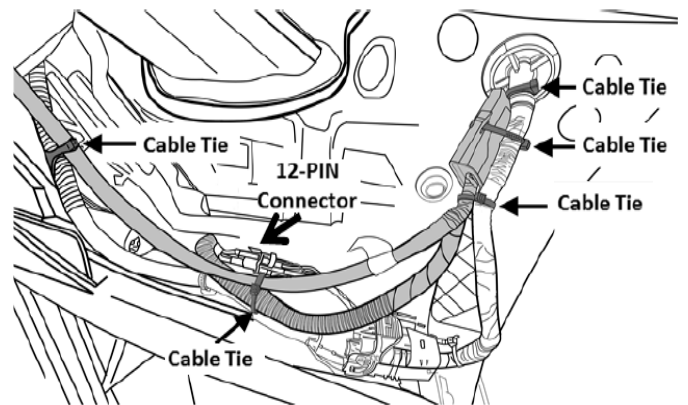

**SUBJECT: TRAILER TOW HITCH HARNESS INSPECTION AND 4 PINS PIGTAIL HARNESS/FUSE REPLACEMENT (RECALL 235)**

9. Using two (2) cable ties, secure the Tow Hitch Harnesses to the vehicle factory harnesses, but do NOT fully tighten the cable ties at this time.



10. Route the Tow Hitch Harness over the bumper beam behind the rear bumper. Fasten and secure harness with (2) cable ties.

Take up any harness slack and tighten the two loose cable ties from step 9. Trim excess cable tie material.

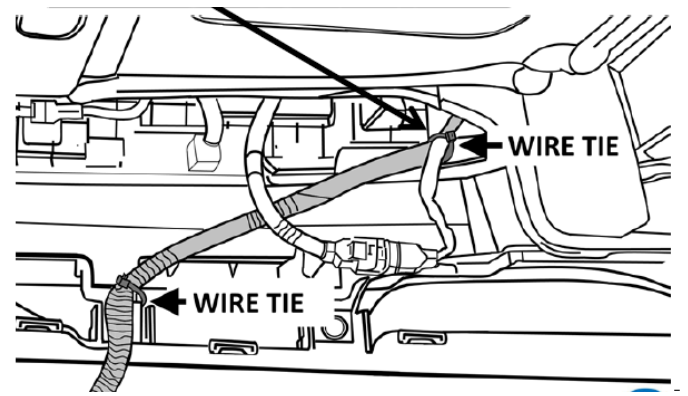

11. Insert the 4-Pin connector into the bracket and tighten the bracket bolts.

**4 pins connector tightening nut:  
7.8 – 9.8 Nm (0.8 – 1.0 kgf.m, 5.2 – 8.7 lb-ft)**



**SUBJECT:**

**TRAILER TOW HITCH HARNESS INSPECTION AND 4 PINS PIGTAIL  
EXTENSION WIRE & HARNESS/FUSE REPLACEMENT (RECALL 235)**

12.

**STUI**



**Using STUI, take a picture of the removed harness with the last 6 digits of the VIN and date of the repair on a piece of paper. Ensure picture is clear before taking. Upload the photo to STUI.**

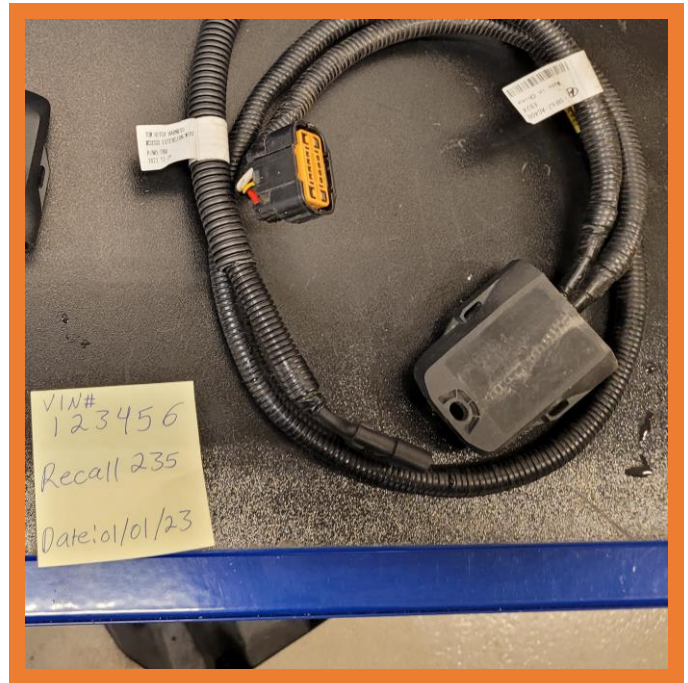

13. Repeat steps 20 through 26 on pages 13-16.

14. Place the tow hitch harness caution card into the glove box.

The procedure is complete.

