



GROUP	MODEL
Safety Recall Campaign	2016MY Sedona (YP) Sorento (UMa)
NUMBER	DATE
SC246	October 2022

SAFETY RECALL CAMPAIGN

SUBJECT:

A/T SHIFT LOCK LEVER AND HOLDER INSPECTION/REPLACEMENT (SC246)

This bulletin provides information to inspect the automatic transmission (A/T) shift lever assembly and, if necessary, replace the shift lock lever and holder set on certain 2016MY Sedona (YP) and Sorento (UMa) vehicles produced in the date ranges listed below. The automatic transmission shift lever assembly contains a shift lock lever and holder. Some shift lock holder components may have been produced out of specification by the supplier. As a result, the shift lock lever may not return to the locked position and the shift lever can be moved out of the "Park" position and into any gear position without pressing the brake pedal, regardless of whether the ignition is on or off. If the transmission gear shifter is moved out of the "Park" position without pressing the brake pedal and the parking brake is not used, a vehicle rollaway can occur thereby increasing the risk of crash and injury. Follow the procedure outlined in this publication to inspect the automatic transmission shift lever assembly and, if necessary, replace the shift lock lever and holder. Before conducting the procedure, verify that the vehicle is included in the list of affected VINs.

Model	Production Date Range
Sedona (YP)	April 27, 2015 to June 27, 2015
Sorento (UMa)	April 27, 2015 to July 9, 2015

NOTICE

There is no charge to the vehicle owner for this repair. Under applicable law, you may not sell or otherwise deliver any affected vehicle until it has been repaired pursuant to the procedures set forth in this bulletin.

NOTICE

To assure complete customer satisfaction, always remember to refer to WebDCS Warranty Coverage (validation) Inquiry Screen (Service → Warranty Coverage → Warranty Coverage Inquiry) for a list of any additional campaigns that may need to be performed on the vehicle before returning it to the customer.

Inspection Procedure:

1. Confirm that gear shifter is in 'P' (Park), turn the ignition to 'ON' position, and engage the parking brake.
2. Depress the brake pedal (A) three (3x) times.



3. Wait 1-2 seconds after releasing the brake pedal, press the shift knob button (B) and attempt to shift the gear shifter from 'P' (Park) to 'D' (Drive).

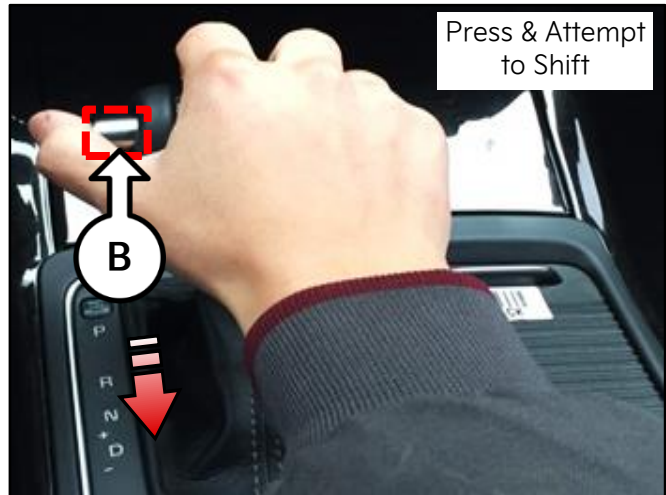

CAUTION
Do not use excessive force when shifting gear.

- Shifting into 'D' was not possible (OK).
- Shifting into 'D' was possible (NG).

4. Repeat steps 2 - 3 two (2x) more times to confirm results.

- 5a.
 - Shifting into 'D' was not possible (OK), no further action is needed.

- 5b.
 - Shifting into 'D' was possible (NG), then replace the shift lock lever and holder:

Replacement Procedures:
Sedona (YP) page 3.
Sorento (UMa) page 4.

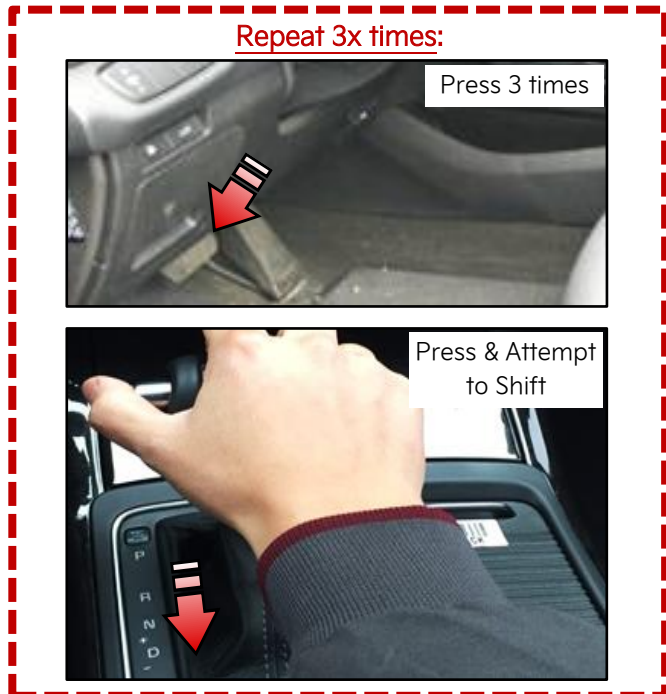

SUBJECT: A/T SHIFT LOCK LEVER AND HOLDER INSPECTION/REPLACEMENT (SC246)
Replacement Procedure: Sedona (YP)

1. Remove the floor console assembly (A) by referring to "Body (Interior and Exterior) → Floor Console → Floor Console Assembly → Repair procedures" in the applicable Shop Manual on KGIS.

NOTICE

Use a non-marring trim removal tool (such as Snap-on® Part Number PBN5 or equivalent) to avoid damaging trim pieces.

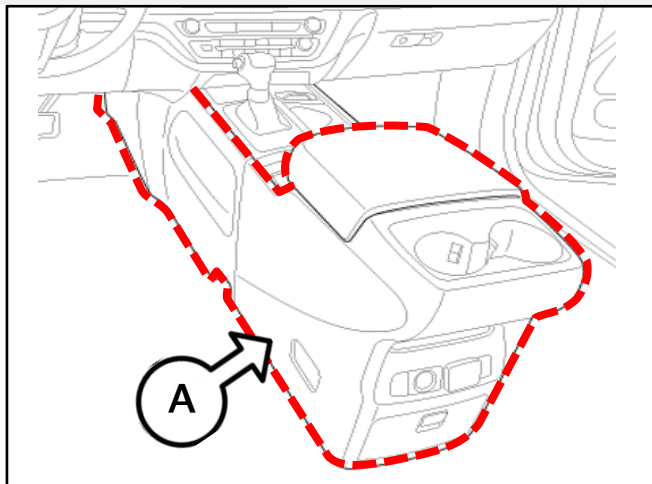

2. Using a flathead screwdriver, remove the shift lock solenoid plastic retaining bracket (C).
3. Using a flathead screwdriver, detach the shift lock solenoid (B) by pulling away on the rod.
4. Loosen the shift lock lever holder retaining screw (E) to replace the shift lock lever and holder set (D).

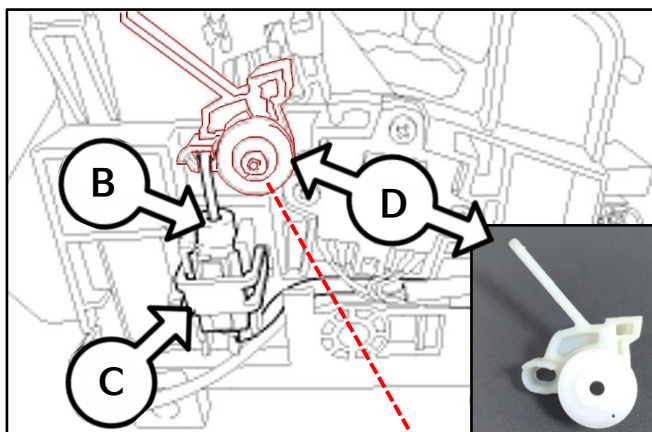

Tightening torque for screw (E):
0.7 - 1.4 lb.ft (1.0 - 2.0 N.m)
DO NOT OVERTIGHTEN.

5. Reinstall the shift lock solenoid (B) and retaining bracket (C).
6. Set the ignition to the 'ON' position.
7. Depress the brake pedal.

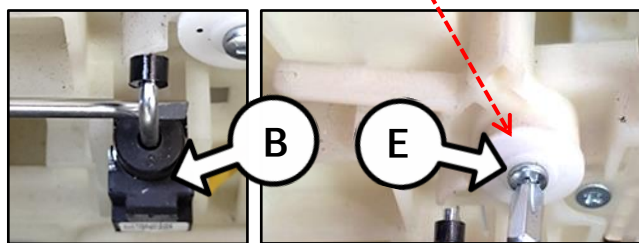

- The shift lock lever & holder set (D) will turn counterclockwise and return to normal position after releasing the brake pedal.

8. Reinstall all removed parts in reverse order of removal.
9. Confirm normal floor console shifter operation.

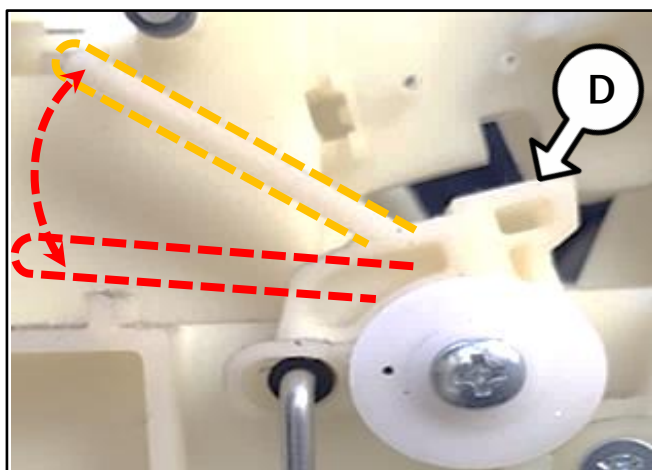

Replacement Procedure: **Sorento (UMa)**

1. Remove the floor console assembly (A) by referring to "Body (Interior and Exterior) → Floor Console → Floor Console Assembly → Repair procedures" in the applicable Shop Manual on KGIS.

 **NOTICE**

Use a non-marring trim removal tool (such as Snap-on® Part Number PBN5 or equivalent) to avoid damaging trim pieces.

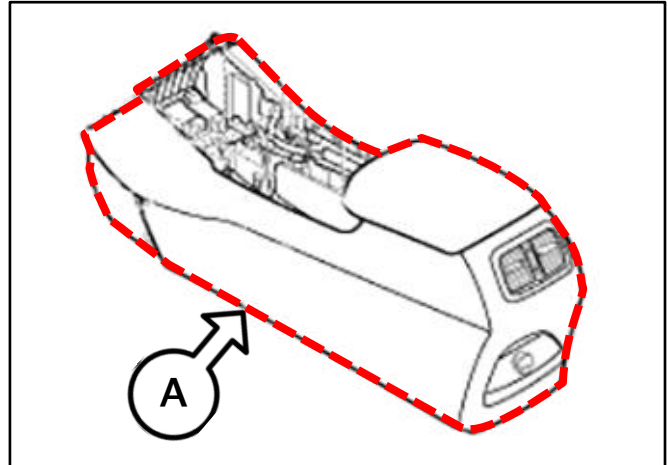

3. Using a flathead screwdriver, detach the shift lock solenoid (B) by unlocking securing tabs and pulling away on the rod.

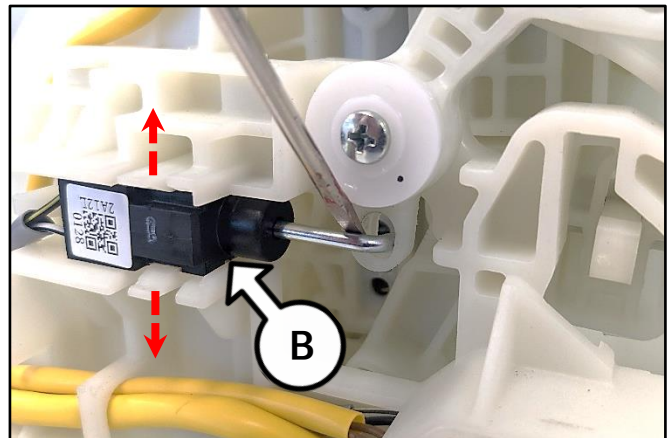

4. Loosen the shift lock lever holder (C) retaining screw (D) to replace the shift lock lever and holder set (C).



Tightening torque for screw (C):
0.7 - 1.4 lb.ft (1.0 - 2.0 N.m)
DO NOT OVERTIGHTEN.

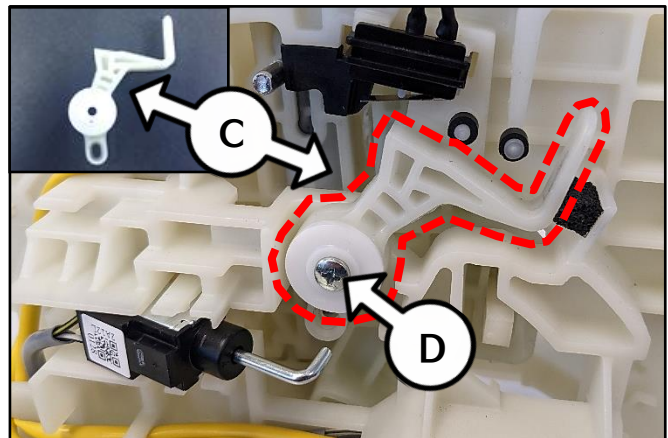

SUBJECT: A/T SHIFT LOCK LEVER AND HOLDER INSPECTION/REPLACEMENT (SC246)

5. Reinstall the shift lock solenoid (B) in the reverse order of removal.

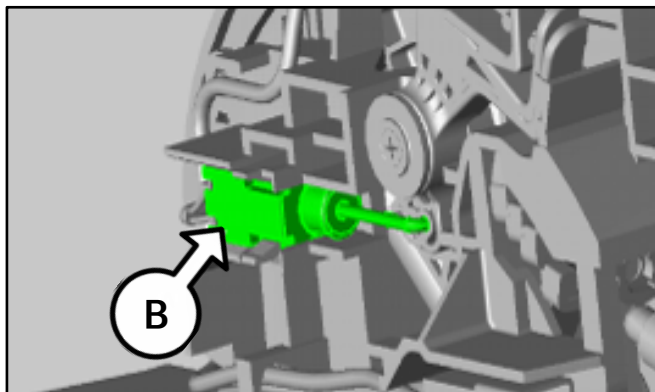

7. Set the ignition to the 'ON' position.

8. Depress the brake pedal.

- The shift lock lever & holder set (C) will turn clockwise and return to normal position after releasing the brake pedal.

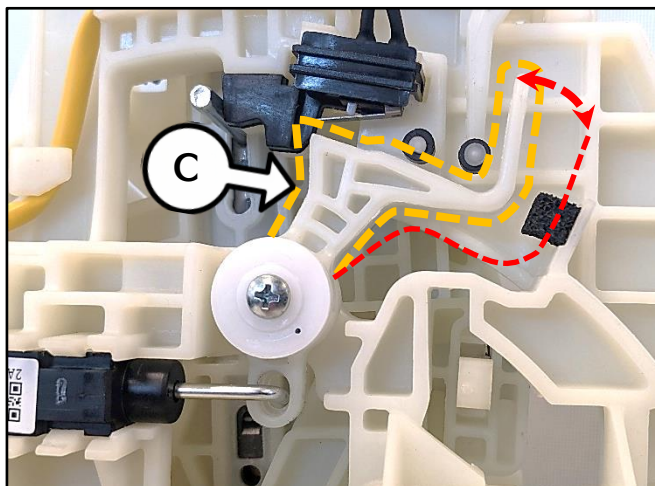

9. Reinstall all removed parts in reverse order of removal.
10. Confirm normal floor console shifter operation.

SUBJECT: **A/T SHIFT LOCK LEVER AND HOLDER INSPECTION/REPLACEMENT (SC246)****AFFECTED VEHICLE RANGE:**

Model	Production Date Range
Sedona (YP)	April 27, 2015 to June 27, 2015
Sorento (UMa)	April 27, 2015 to July 9, 2015

REQUIRED PART:

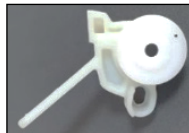
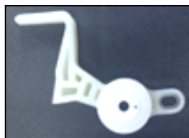
Model	Part Name	Part Number	Figure	Qty.
Sedona (YP)	Shift Lock Lever & Holder Set	46735 A900XQQK		1
Sorento (UMa)		46735 C5100QQK		1

WARRANTY INFORMATION:**N Code: N99 C Code: C99**

Model	Claim Type	Causal P/N	Qty.	Repair Description	Labor Op Code	Op Time	Replacement P/N	Qty.
YP	R	46735 A9000	0	(SC246) A/T Shift Lever Assembly Inspection	221103R0	0.2 M/H	N/A	0
UMa		46735 C5100			221A19I0			
YP		46735 A9000	0	(SC246) A/T Shift Lever Inspection and Replacement of the Shift Lock Lever & Holder Set	221103R2	0.6 M/H	46735 A900XQQK	1
UMa		46735 C5100			221A19R0	0.5 M/H	46735 C5100QQK	

Refer to Warranty Bulletin 2022-35 for claim submission procedures.

NOTICE

VIN inquiry data for this repair is provided for tracking purposes only. Kia retailers should reference **SC246** when accessing the WebDCS system.