

Keystone RV Company

11/18/22

SAFETY ADVISORY # 22-434

Lippert Awnings

Keystone is conducting a voluntary RECALL notification campaign in accordance with the National Highway Transportation and Safety Act. It has been decided that vehicles in the recall population were built with a certain Lippert Electric Retractable Awnings, up to 18 feet in length, that the heat-welded seam may separate. Under certain conditions during use or travel the welded seam on the fabric may separate, potentially allowing the awning fabric to become detached from the side of the vehicle and drop beyond normal operation; leading to an increased risk of personal injury.

Models Included:

Year	Model	Serial Number Ranges
2022	Aspen Trail – 18' awnings and under	N8923694 - N8925682 NJ924293 - NJ924870
2022 - 2023	Bullet – 18' awnings and under	ND433673 - ND435903 NT432741 - NT436083 PT430074 - PT430074
2022	Carbon – 18' awnings and under	NR805381 - NR805812
2022	Coleman – 18' awnings and under	NH940948 - NH946812 NJ940906 - NJ946769 NM941421 - NM947019
2022	Colorado – 18' awnings and under	N8950639 - N8950903
2022	Cougar – 18' awnings and under	N2504341 - N2510550 NV505004 - NV510556
2022	Hideout – 18' awnings and under	NW246704 - NW251714
2022	Montana – 18' awnings and under	N4703457 - N4703762
2022	Outback – 18' awnings and under	NW452437 - NW452740
2022	Passport – 18' awnings and under	ND413571 - ND415592 NK412945 - NK416142
2022	Raptor – 18' awnings and under	NR800531 - NR801105
2022	Retreat – 18' awnings and under	NW260180 - NW260321
2022	Springdale – 18' awnings and under	N3106372 - N3111953 NW107274 - NW109957
2022	Sprinter – 18' awnings and under	N1531202 - N1532747
2022	Voltage – 18' awnings and under	NZ990647 - NZ991219
2022	Yukon – 18' awnings and under	NZ980412 - NZ980891

Parts Required:

Per inspection of awning:

1 – KRV# 708044 - Awning - Seam Repair - Adhesive (this part may be ordered in bulk without a VIN)

1 – Awning fabric – per inspection – See Key Express parts catalog for boxed fabric part number (This part must be ordered by VIN)

Tools Required: By inspection - See Lippert instructions below.

PHOTOS ARE REQUIRED OF AWNING TAG AND ANY FABRIC WELD CONCERNS.

Note – Check serial number on Key Express to verify the campaign is open. Some vehicles were repaired before they left Keystone.

When performing warranty or recall service, please make certain that appropriate Personal Protective Equipment (PPE) is used.

The Lippert instructions have been included. The remedy is to review the awning tag. If it is an awning with a light strip manufactured between January 17, 2022 and June 14, 2022, take a photo of the tag and perform push/pull test to test the weld near the awning rail attached to the sidewall of the unit. If a separation exists/occurs, a photo is required. If the separation is 6” or less, perform the repair. If the separation is 6” or more, replace the awning fabric.

INSPECTION and REPAIR INSTRUCTIONS - PHOTOS REQUIRED

Step 1

Locate the trailer on a level, flat, hard surface. Chock the wheels. Disconnect 12VDC and 120VAC.

Step 2

Inspect the awning tag to determine if the awning is affected. If awning is affected follow the attached instructions for inspection and repair guidelines if separation is under 6”. If separation is over 6” go to step 3. For inspection only proceed to warranty reimbursement.

REPLACEMENT INSTRUCTIONS – PHOTOS REQUIRED

Step 3

If seam separation occurs of over 6”, take a picture of the failure and follow industry guidelines and replace the awning fabric. A link to fabric replacement can be found on the repair document above, or on Lippert’s website at www.lci1.com. Awning fabric parts order must be placed through KRV parts by VIN. See parts catalog on Key Express for fabric part numbers by model. **Note:** Boxed fabrics must be installed or removed from the box and properly rolled to prevent damage to the fabric before the expiration date. Fabric damaged from not being used by expiration dates will not be eligible for an RGA.

Step 4

Proceed to warranty reimbursement.

WARRANTY REIMBURSEMENT**INSPECT – PHOTOS REQUIRED**

Submit a claim with photos of awning tag on Key Express using **Flat Rate Code # 7143442K**

In the Complaint section note: Safety Advisory # 22-434

In the Cause section note: Safety Advisory # 22-434

In the Correction section note: Awning inspected fabric is NOT separating.

The amount of time authorized for this repair is **0.3 hour**.

REPAIR – PHOTOS REQUIRED

Submit a Pre-Authorization request with photos then claim on Key Express using **Flat Rate Code # 7143442A**

In the Complaint section note: Safety Advisory # 22-434

In the Cause section note: Safety Advisory # 22-434

In the Correction section note: Awning fabric is separating – under 6” repaired fabric
or

Awning fabric is separating – over 6” replaced fabric.

Some Models have two awnings. Each awning will require a separate claim line to accumulate time.
The amount of time authorized for this repair is:

Inspection plus repair is **0.6 hour**.

Inspection plus replacement is **1.8 hours**.

Please call Keystone RV Customer Service if you have any questions:

Dutchmen - 855-382-4100

Light Weight - 866-273-1456

Luxury - 866-273-1450

Premium - 866-273-1454

Toy Haulers - 866-273-1452

Traditional - 855-895-4422

AWNING INSPECTION AND WELD/SEAM REPAIR

Recall Number:	Lippert - 22E-055 Keystone - 22-434		
Product:	Awnings		
Date:	Sept. 15, 2022	Labor Rate:	.30 hours inspection only .30 hours repair only 1.5 hours fabric replacement only

Purpose

The purpose of this document is to provide guidance, as well as visual aides, to dealers performing inspection on units that may have insufficient awning weld(s). The inspection point is at the awning fabric seam at the awning rail at the wall of the unit (Fig. 1). This only affects awnings manufactured January 17, 2022 – June 14, 2022. The date of manufacture can be located on the variant code label (Fig. 2) located on the awning.

Fig. 1

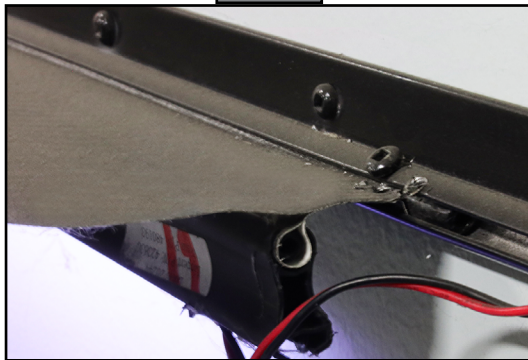
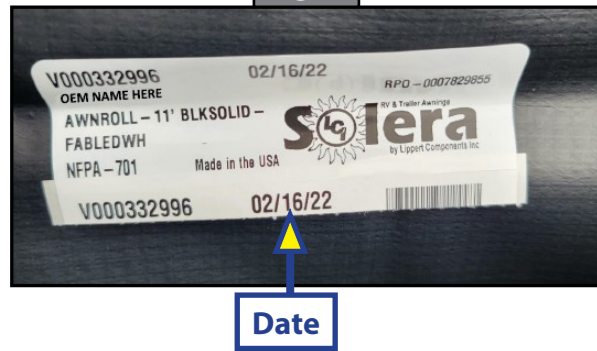

Fig. 2



Resources Required

- Stepladder of adequate height to perform push test and inspect weld near awning rail

Instructions

Push Test

1. Extend the awning.
2. From underneath the awning, about 1" to 1.5" from the fabric edge, push up on the fabric with one finger (Fig. 3) until the awning fabric is flush with the top of the awning rail. Look for any separation or visible daylight at the seam. Perform push test at both ends of the awning.

Fig. 3

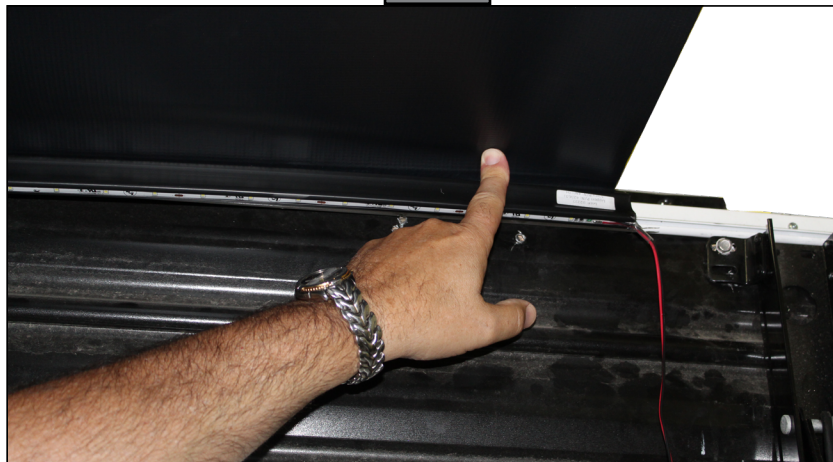

AWNING INSPECTION AND WELD/SEAM REPAIR

Recall Number:	Lippert - 22E-055 Keystone - 22-434		
Product:	Awnings		
Date:	Sept. 15, 2022	Labor Rate:	.30 hours inspection only .30 hours repair only 1.5 hours fabric replacement only

Top Inspection

1. Position stepladder next to the unit to view the topside of the awning at the unit wall from either end (drive/idler side).
2. Inspect the weld near the awning rail (Fig. 4A).
 - A. Fig. 4 shows no separation at the seam. It does not require repair or replacement.
 - B. Fig. 5 shows separation at the seam (Fig. 5A).
 - I. If the separation is less than 6 inches, repair can be accomplished using the procedure described in [TI-434](#).
 - II. If the separation is over 6 inches it will require awning fabric replacement using the procedure described in [TI-166](#).

Fig. 4

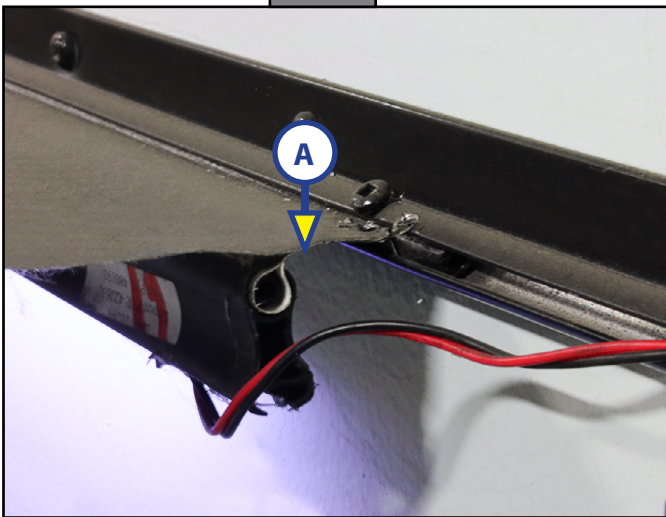
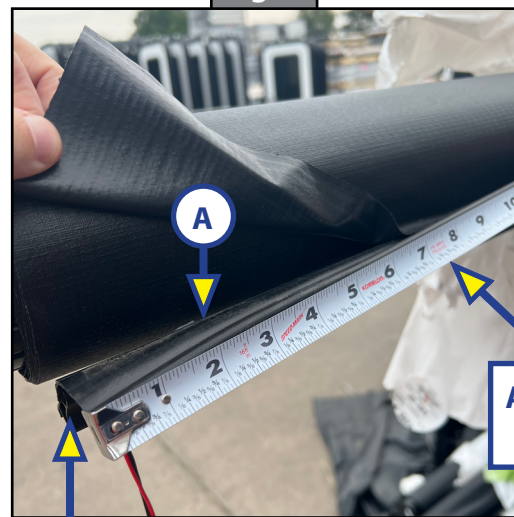

Fig. 5



Light strip location

Awning rail location

All inspections and repairs must be documented with the following information:

- Full unit information, including 17-digit VIN and Make/Model
- Clear photo of the awning tag
- Photos documenting any weld separation concerns

AWNINGS

Purpose

This document outlines the repair of awning fabric that has separated at the seam using Awning Seam Repair Adhesive PN 2022107896 (Fig. 1).

Fig. 1



PN 2022107896

Safety**⚠ WARNING**

The "WARNING" symbol above is a sign that a procedure has a safety risk involved and may cause death, serious personal injury or product and/or property damage if not performed safely and within the parameters set forth in this manual.

⚠ WARNING

Repair compounds can be highly flammable. Do not use around open flame or other heat sources.

⚠ WARNING

Repair compounds may cause eye and skin irritation. May also cause drowsiness and dizziness. Use in a well-ventilated area as prolonged exposure to fumes can cause irritation to nose, mouth, throat and respiratory system. FOLLOW THE SAFETY PRECAUTIONS ON THE LABEL BEFORE USING THE REPAIR COMPOUNDS.

⚠ CAUTION

The "CAUTION" symbol above is a sign that a procedure has a safety risk involved and may cause personal injury, product and/or property damage if not performed safely and within the parameters set forth in this manual.

⚠ CAUTION

Always use personal protective equipment (PPE) such as gloves and eye protection when working with chemical compounds.

AWNINGS

Resources Required

- Awning Seam Repair Adhesive PN 2022107896 (Fig. 1)
- Mild soap and water
- Ladder, if needed, to reach the awning rail or roll tube

Seam Separation Repair Procedure

NOTE: The repair procedure is optimal for 6 to 8" seam separations or less (Fig. 2).

1. Extend the awning:
 - A. For a seam fix at the awning rail, extend the awning a few feet.
 - B. For a seam fix at the roll tube, extend the awning completely.
2. Tie both awning arms slightly back to gain some slack in the fabric.
3. Clean the area to be repaired with mild soap and water. Allow to dry completely.
4. Spread open the seam area needed repair and apply a continuous bead of Awning Seam Repair Adhesive PN 2022107896 along the entire separation (Fig. 3).
5. Press down firmly and hold for several minutes.
6. Allow to dry for at least four hours.

Fig. 2

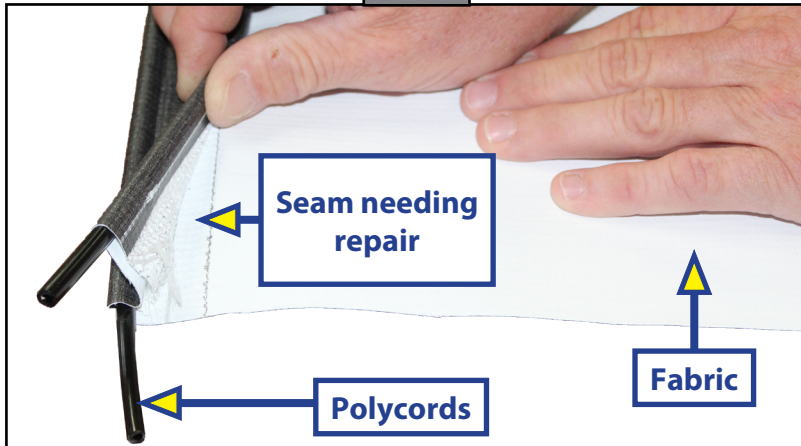

Fig. 3



NOTE: Photo shows fabric removed from the awning for clarity and upside down. The repair can be completed with the awning fabric installed.

AWNINGS

Purpose

This document outlines the removal and replacement of awning fabric.

Resources Required

- 1 to 3 People
- Cordless or Electric Drill or Screw Gun
- Appropriate Drive Bits
- Zip Ties
- Two Cotter Pins (manual awning only)
- Non-Permanent Marker

Safety

CAUTION

Moving parts can pinch, crush or cut. Keep clear and use caution.

NOTE: Previous awning versions had two (2) polycords and fabric stitching along the hem. The current awning model has one (1) polycord (see Fig. 1) and no fabric stitching. This should not be mistaken as defective.

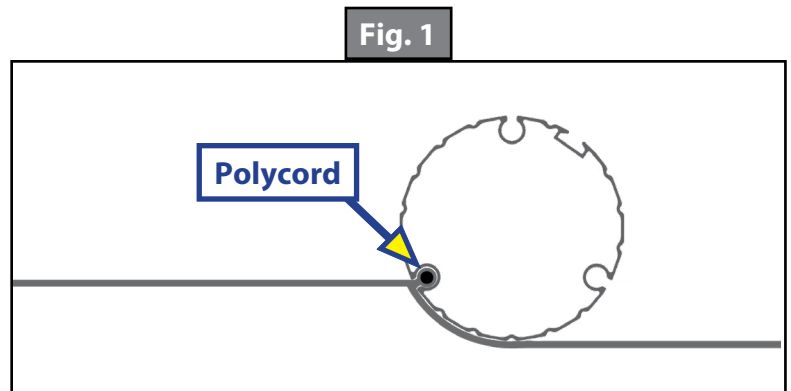

Manual Awning Fabric Replacement

Removal

1. Remove the drip cap (if equipped) from the end of the awning from which the fabric will be removed.
2. Extend the awning out approximately 12" and insert cotter pins through both end caps into the shafts on the head assemblies (Fig. 2).

NOTE: If the awning is 6' in length it will only need one cotter pin for the drive side end cap.

3. Secure both support arm assemblies by running a zip tie around the outer arm and around the pin on the top of the mount arm where the mount arm and inner arm connect (Fig. 3).
4. Remove the screws holding the polycord in place on the awning rail.

WARNING

If not properly secured, the support arms can kick out due to pressure from the gas strut, which may result in serious injury or property damage.

AWNINGS

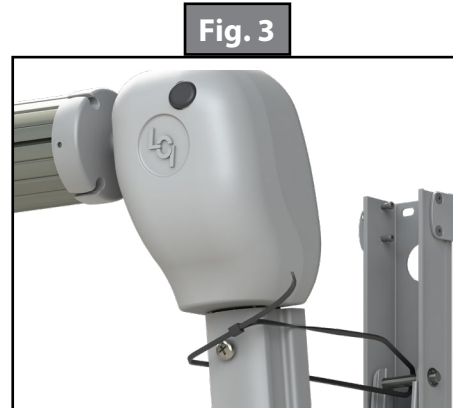
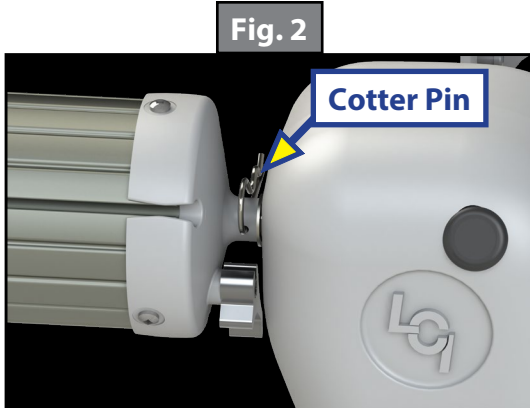

5. Remove the drive head assembly and idler head assembly retaining bolts from the outer arms to separate the components.
6. Working together, remove the roll tube assembly (which includes the drive/idler head assemblies) from the awning rail and support arms by sliding the assembly along the awning rail until clear.
7. Secure the idler head and the roll tube to a work bench.

⚠ WARNING

Failure to support the roll tube, fabric and drive/idler head assemblies during removal may result in serious injury or property damage.

8. Hold the drive head assembly securely (there will be tension to be released) while another person removes the drive head assembly cotter pin.
9. While one person holds the roll tube, have another person slowly rotate the drive head assembly clockwise to release tension.

⚠ WARNING

Failure to maintain control of the roll tube, fabric and drive/idler head may result in serious injury or property damage.

10. Mark the cam lock position on the roll tube with a non-permanent marker.
11. Remove the three screws holding the drive head assembly end cap on the roll tube and set the drive head assembly aside.

NOTE: Awnings longer than 6' will also have tension that needs to be released in the idler head assembly prior to continuing the procedure. To release tension, remove the idler head cotter pin and slowly rotate the idler head in a counterclockwise motion to release tension in the idler head assembly's spring.

12. Place the roll tube and fabric on a clean, level surface that is free of any debris able to scratch or damage the roll tube and/or fabric.
13. With one person holding the awning rail end of the fabric, another can rotate the roll tube to unroll the fabric until only the polycord is left on the roll tube.
14. Remove the screws holding the polycord in place on the roll tube.
15. Mark the roll tube groove containing the polycord with a non-permanent marker prior to removing the fabric from the roll tube.
16. To remove the fabric, gently pull the roll tube from the idler end, while another person holds the fabric in place.

AWNINGS

Installation

1. Unroll the replacement fabric printed side down so that the polycord is parallel and away from the roll tube.
2. On a clean, level surface free of any debris able to scratch or damage the roll tube, gently slide the roll tube onto the polycord of the fabric, making sure that the non-printed side is touching the roll tube (Fig. 4).
3. Center the fabric on the roll tube.
4. Apply the screws that were holding the polycord in place on the roll tube. Install the screws no more than 1" from the edge of the fabric.

Fig. 4

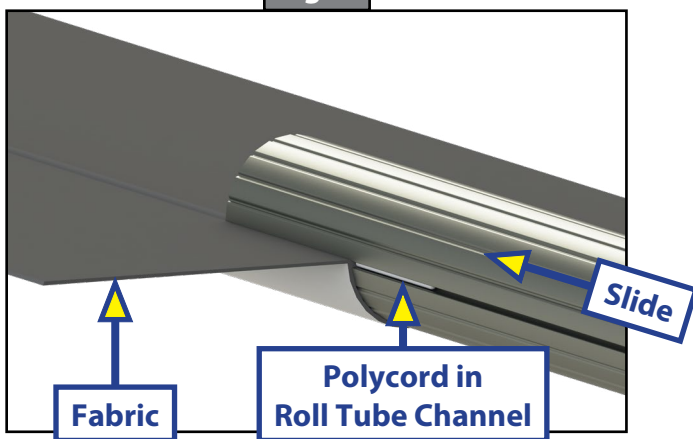
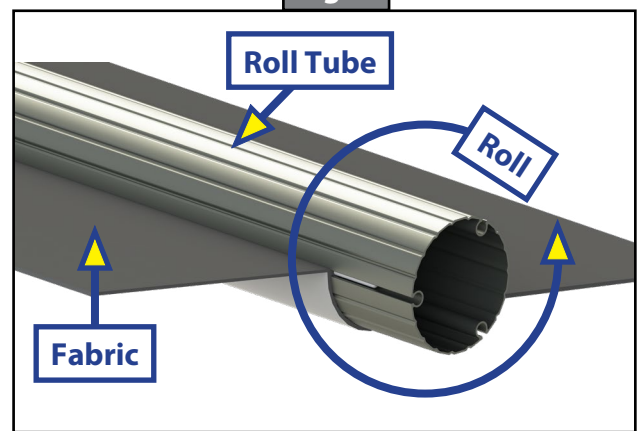

Fig. 5



5. Roll the fabric onto the roll tube (Fig. 5). Make sure the fabric stays snug and flat to the roll tube with the printed side facing away.
6. Using the three screws previously removed from the drive head assembly end cap, attach the drive head to the roll tube, making sure the orientation is the same.

NOTE: Be sure the drive head assembly with the cam lock is on the right-hand side of the awning.

7. Secure the idler head and roll tube to the work bench.
8. Rotate the drive head assembly counterclockwise, proper turns according to the length of the awning (Fig. 6) and insert a cotter pin into the end cap into the shaft on the drive head assembly.

Fig. 6

Manual Awning Tensioning	
Awning Length	Proper Tensioning (# of turns)
6'*	15
7'-16'	9
17'-21'	10
22'-28'	11
NOTE: *6' Awnings only have one spring to tension on the drive side.	

AWNINGS

⚠ WARNING

Failure to support the roll tube, fabric and drive/idler head assembly during installation may result in serious injury or property damage.

NOTE: If the awning is longer than 6' and the idler head assembly tension had previously been released, rotate the idler head assembly clockwise according to the length of the awning (Fig. 6) and insert a cotter pin into the end cap into the shaft on the idler head assembly. Be sure that both head assemblies are parallel once tension has been added.

9. Working together, install the roll tube assembly (which includes the drive/idler head assemblies) to the awning rail and support arms by sliding the assembly along the awning rail. Make sure the awning will unroll with the printed side of the fabric up.
10. Install the previously removed drive/idler head assembly retaining bolts into the outer arms to secure.
11. Remove the cotter pins from both end caps and cut the zip ties from the support arm assemblies.
12. Extend and retract the awning several times to ensure that the fabric is square on the roll tube.
13. Secure the fabric in the awning rail 1" inside the edge of the fabric on both ends using a #6 x 1/2" hex head screw. Install the screw down through the awning rail into the fabric and the polycord (Fig 7).
14. Reinstall the drip cap (if previously equipped).

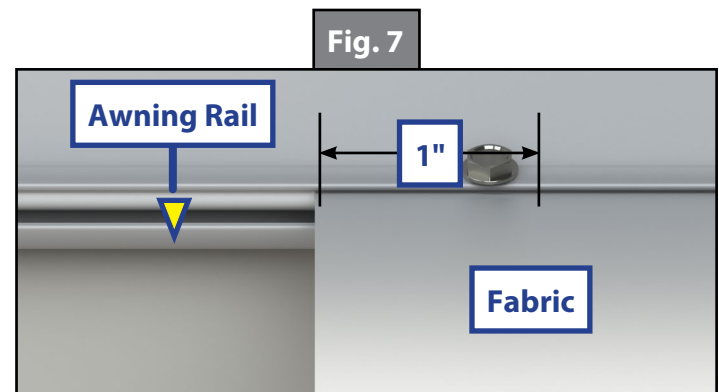

Power and Hybrid Awning Fabric Replacement

Resources Required

- 1 to 3 People (depending on task)
- Cordless or Electric Drill or Screw Gun
- Appropriate Drive Bits
- Zip Ties

Removal

1. Remove the drip cap (if equipped) from the end from which the fabric will be removed.
2. Fully extend the awning.
3. Disconnect any fabric LED lights in the support arm assembly or remove the fabric LED light strip from the polycord of the fabric.
4. Retract the awning until approximately 12" remain visible.
5. Secure both support arm assemblies by running a zip tie around the outer arm and around the pin on the top of the mount arm where the mount arm and inner arm connect (Fig. 8).
6. Remove the screws holding the polycord in place on the awning rail.
7. Remove the wax screws holding the end caps onto the drive and idler head shafts (Fig. 9).
8. Working together, remove the roll tube and fabric from the awning rail and support arm assemblies.
9. Place the roll tube and fabric on a clean, level surface that is free of any debris able to scratch or damage the roll tube and/or fabric.

AWNINGS

Fig. 8



Fig. 9



⚠ WARNING

Failure to support the roll tube, fabric and drive/idler head assembly during installation may result in serious injury or property damage.

10. Remove the end cap from the end of the roll tube from which the fabric will be removed.
11. With one person holding the end of the fabric that gets attached to the awning rail on the unit, another can rotate the roll tube to unroll the fabric until only the polycord is left on the roll tube.
12. Remove the screws holding the polycord in place on the roll tube.
13. To remove the fabric, gently pull the roll tube from one end, while another person holds the fabric in place.

Installation

1. Unroll the replacement fabric so that the cords are parallel with the roll tube.
2. On a clean, level surface free of any debris able to scratch or damage the roll tube, gently slide the roll tube onto the polycord of the fabric, making sure that the non-printed side is touching the roll tube (Fig. 10).
3. Center the fabric on the roll tube.
4. Install the screws that were holding the polycord in place on the roll tube. Install the screws no more than 1" from the edge of the fabric.
5. Roll the fabric onto the roll tube (Fig. 11). Make sure the fabric stays snug and flat to the roll tube with the printed side facing away.

Fig. 10

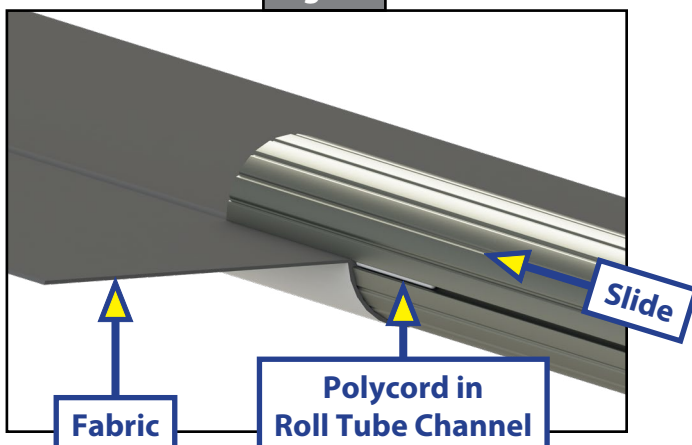
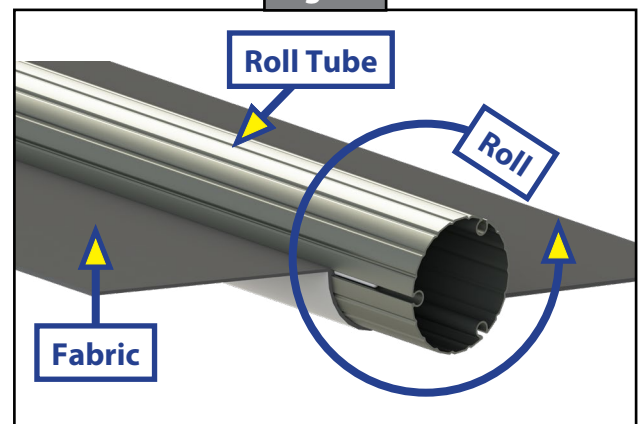

Fig. 11



AWNINGS

6. Reinstall the end cap previously removed.
7. Working together, install the roll tube and fabric on the awning rail and support arms, making sure the awning will unroll with the printed side of the fabric up.

⚠ WARNING

Failure to support the roll tube, fabric and drive/idler head assembly during installation may result in serious injury or property damage.

8. Working together, slide the shaft on the head assembly into the end cap. Install the wax screws at each end to secure the roll tube end caps to the head assemblies.

NOTE: It is suggested to keep the head of the wax screw $\frac{1}{8}$ " from fastened so as not to compromise the structural integrity of the wax screw.

9. Extend and retract the awning several times to ensure that the fabric is square on the roll tube.
10. Secure the fabric in the awning rail no more than 1" inside the edge of the fabric on both ends using a #6 x $\frac{1}{2}$ " hex head screw. Install the screw down through the awning rail into the fabric and the polycord (Fig. 12).

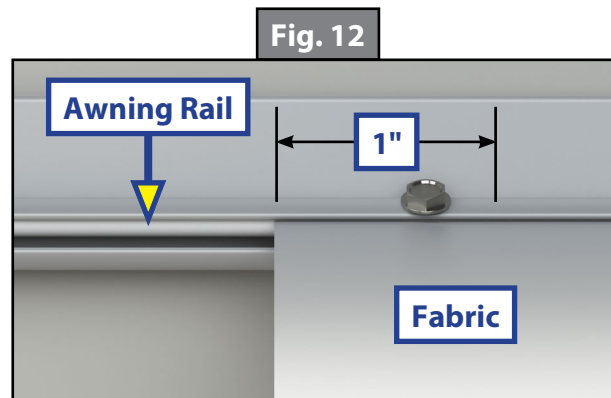

11. Reinstall the drip cap (if previously equipped).
12. Reconnect any light wiring as needed.

NOTE: The fabric LED light strip will need to be installed on the polycord of the fabric prior to connecting any wiring previously removed.