

**TECHNICAL INSTRUCTIONS**  
**FOR**  
**SAFETY (NONCOMPLIANCE) RECALL 22TA09**  
**UPPER CHILD SEAT ANCHOR WELDS MAY FAIL DURING A CRASH**  
**CERTAIN 2022-2023 MODEL YEAR TACOMA VEHICLES**

**Technician Training Requirements for the Technical Instructions**

The repair quality of covered vehicles is extremely important to Toyota. All dealership technicians performing the child seat anchor weld inspection procedure (Section VI in the Technical Instructions) are required to successfully complete the most current version of the E-Learning course “Safety Recall and Service Campaign Essentials”. To ensure that all vehicles have this inspection performed correctly; technicians performing this inspection are required to currently hold at least one of the following certification levels:

- Expert Technician (any specialty)
- Master Technician
- Master Diagnostic Technician

Always check which technicians can perform the inspection by logging on to <https://www.uotdealerreports.com>. It is the dealership’s responsibility to select technicians with the above certification level or greater to perform this inspection. Carefully review your resources, the technician skill level, and ability before assigning technicians to this repair. It is important to consider technician days off and vacation schedules to ensure there are properly trained technicians available to perform this inspection at all times.

*Note:*

- 1.) Only authorized Toyota dealers are authorized to perform the child seat anchor weld inspection procedure (Section VI in the Technical Instructions). Non-Toyota dealer entities (such as a third-party collision centers, or a Toyota Certified Collision Center) are not authorized to perform the child seat anchor weld inspection procedure.
- 2.) If required, the Weld Repair (Sections VII – XIV in the Technical Instructions) is typically performed by a non-Toyota dealer entity (such as a third-party collision center or a Toyota Certified Collision Center) and thus, there are no specific technician training requirements for performing the Weld Repair instructions. But dealers and non-dealer entities should use technicians with the appropriate skills and should follow the Weld Repair instructions.

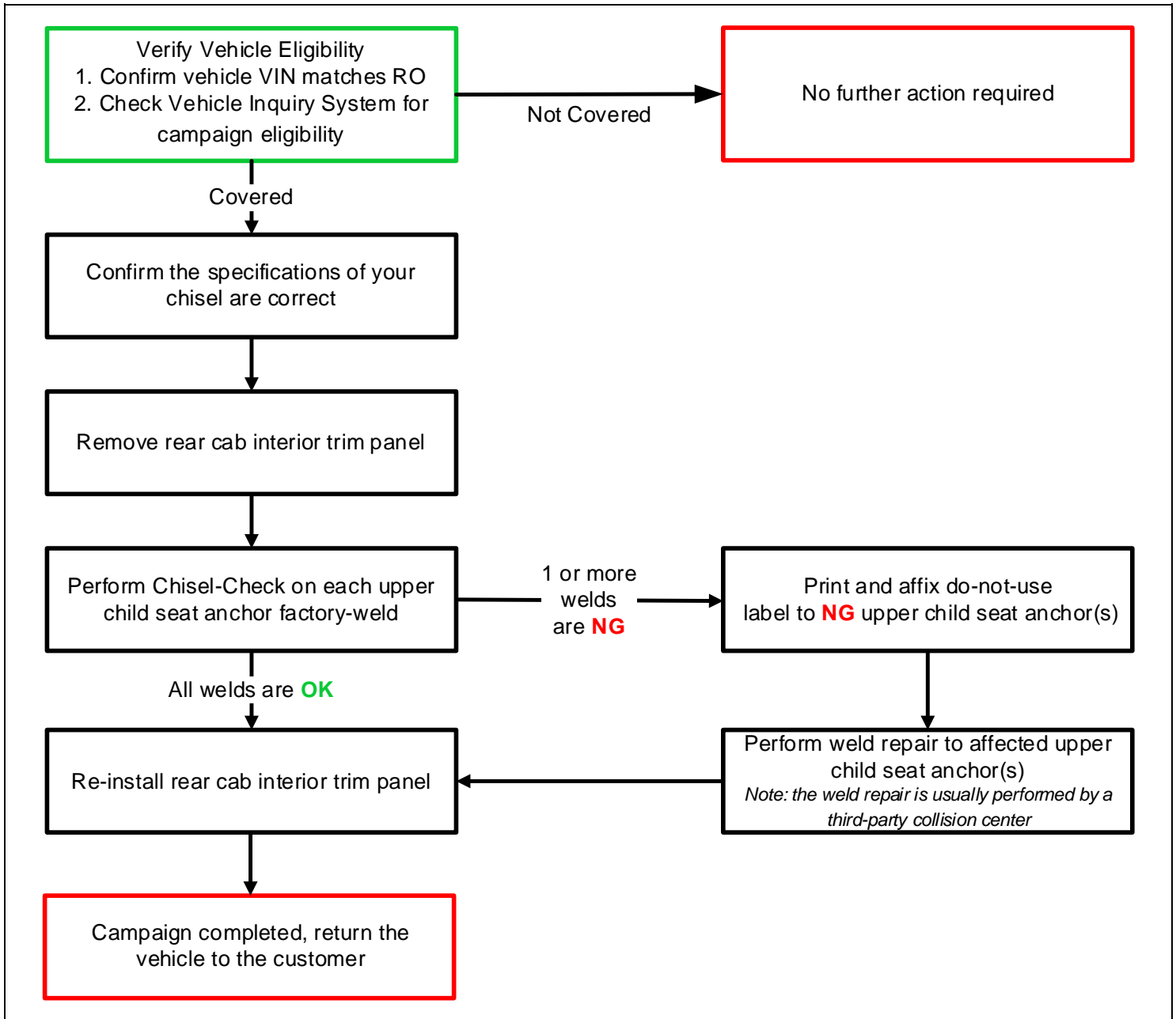

## I. IDENTIFICATION OF AFFECTED VEHICLES

Check the TIS Vehicle Inquiry System to confirm that each VIN is eligible for this Safety Recall, and that it has not already been completed prior to dealer shipment or by another dealer.

Note: TMNA warranty will not reimburse dealers for repairs completed on vehicles that are not affected or were completed by another dealer.

## II. BACKGROUND

The upper child seat anchors of the involved vehicles may not have been welded sufficiently and may not meet minimum strength requirements. Vehicles with upper child seat anchor welds that do not meet strength requirements do not comply with applicable regulations in the U.S. An insufficient weld may allow the child seat to move during a sudden stop or crash, increasing the risk of injury.

*Note: At this time, Toyota expects approximately 1 out of every 20 vehicles (about 5%) will have at least one insufficient weld identified.*

### III. COMPONENTS



## IV. PREPARATION

### A. TOOLS, SUPPLIES & EQUIPMENT

- Standard hand tools
- 3/8" Chisel, refer to specifications below
- 1-1/2 lb.(24oz) Hammer
- Torque wrench

### 3/8" Chisel – Specifications



- If your chisel does not meet these specifications, you could damage the vehicle and the results of the check may not be valid
- Blade must be in good condition: not dull, blunted, or chipped

#### Examples of Acceptable Chisels

- **Mayhew Pro 10202** (single chisel)
- **Mayhew Pro 60560** (use the 3/8 chisel in the set)
- **Proto J86A3/8** (single chisel)
- **Proto J86000** (use the 3/8 chisel in the set)
- **Proto J2** (use the 3/8 chisel in the set)
- **Westward 2AJH6** (single chisel)
- **Westward Set 2AJL5** (use 3/8 chisel in the set)



Blade Angle  
12° +/- 0.5°



### Chisel Angle Checker

If you ordered a chisel that was not listed above, confirm it has a 12° angle by placing the tip here. Watch the video demonstration on page 9 as well.



## V. REMOVE REAR CAB INTERIOR PANEL

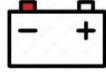

1. DISCONNECT NEGATIVE BATTERY CABLE

2. FOLD UP SEAT BENCH

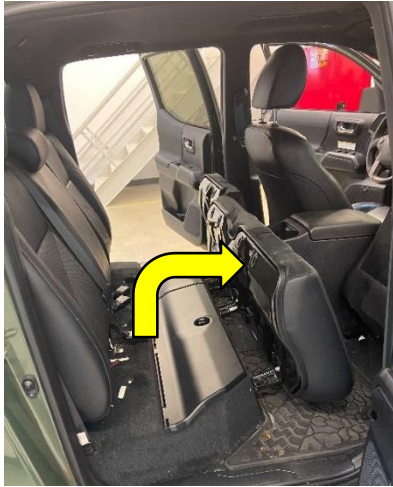

3. UNBOLT THE MIDDLE SEAT BELT FROM THE FLOOR



4. REMOVE REAR SEAT HEAD RESTS



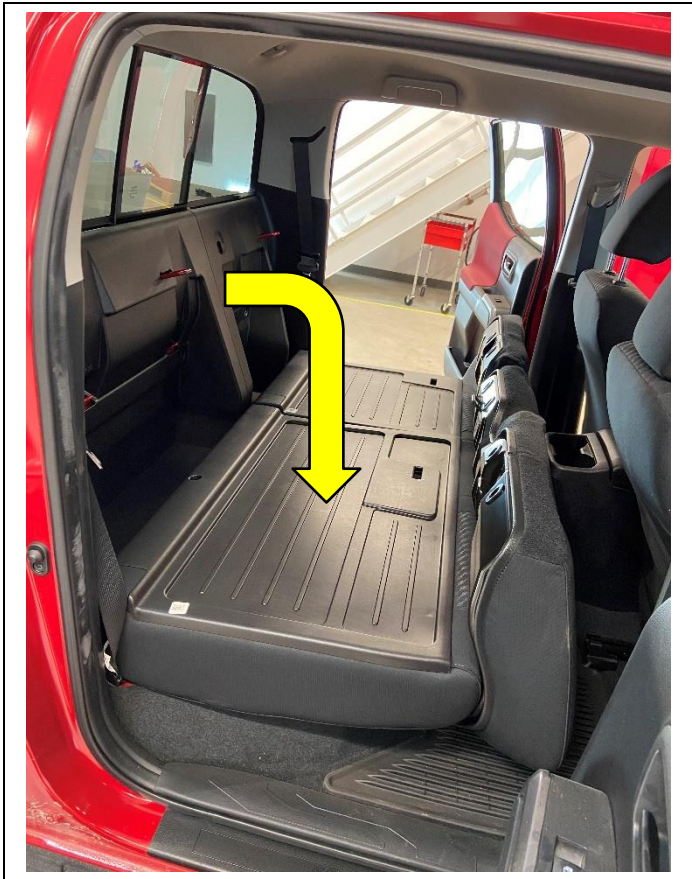

## 5. FOLD DOWN SEAT BACKS

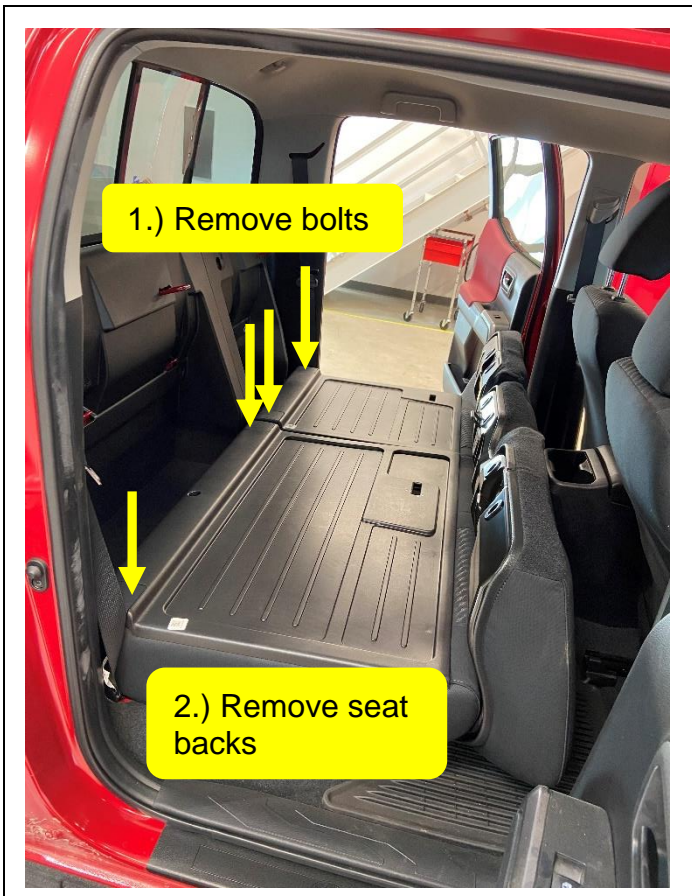

## 6. UNBOLT SEAT BACKS FROM SEAT HINGE

- Remove the four (4) bolts as shown in the diagram

**Note:** Do not unbolt the hinge from the floor. Just unbolt the seat from the hinges and leave the hinges attached to the floor.

## 7. REMOVE SEAT BACKS



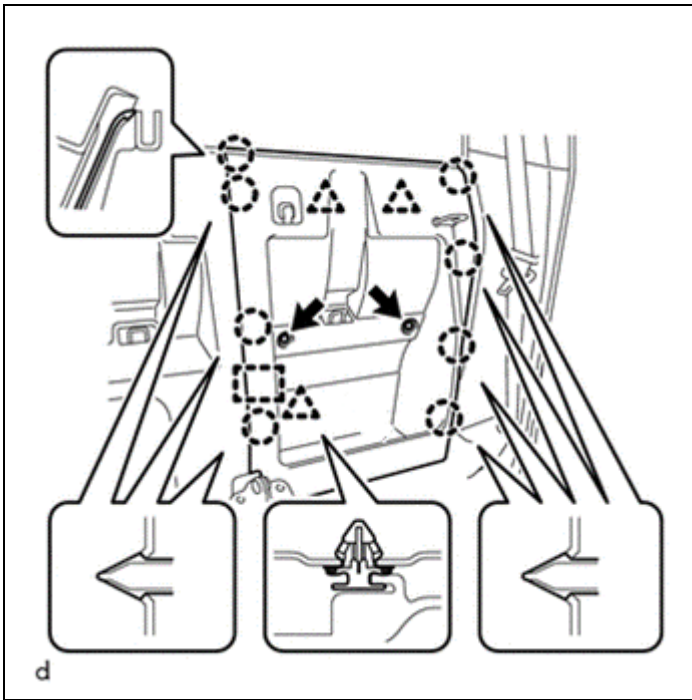

- 8. REMOVE LUGGAGE COMPARTMENT SIDE TRAY LH**
- a. Remove the five (5) bolts as shown in the diagrams. If equipped with a subwoofer, there are four (3) total bolts.

**9. REMOVE LUGGAGE COMPARTMENT SIDE TRAY RH**

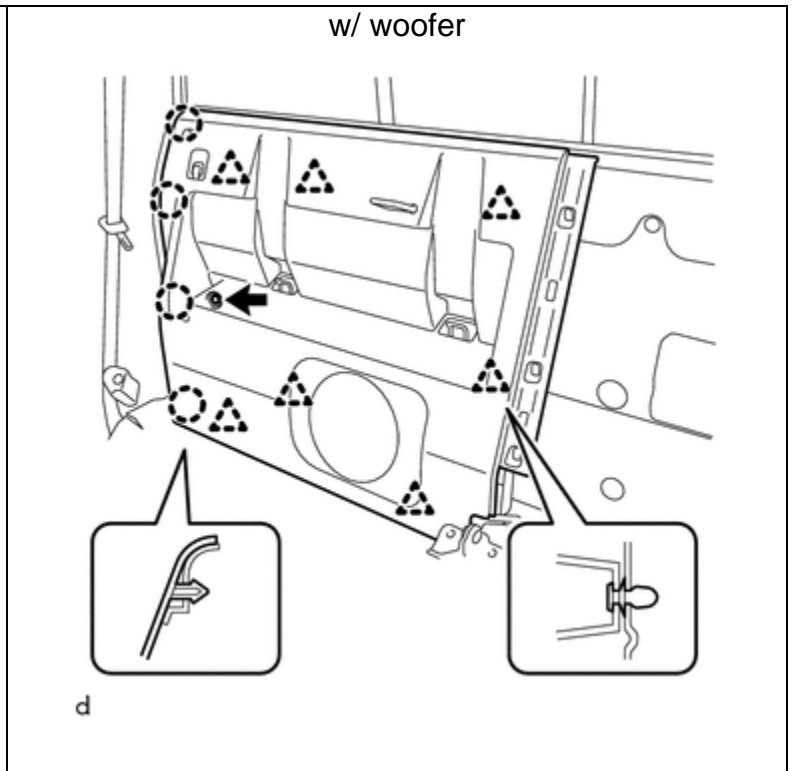
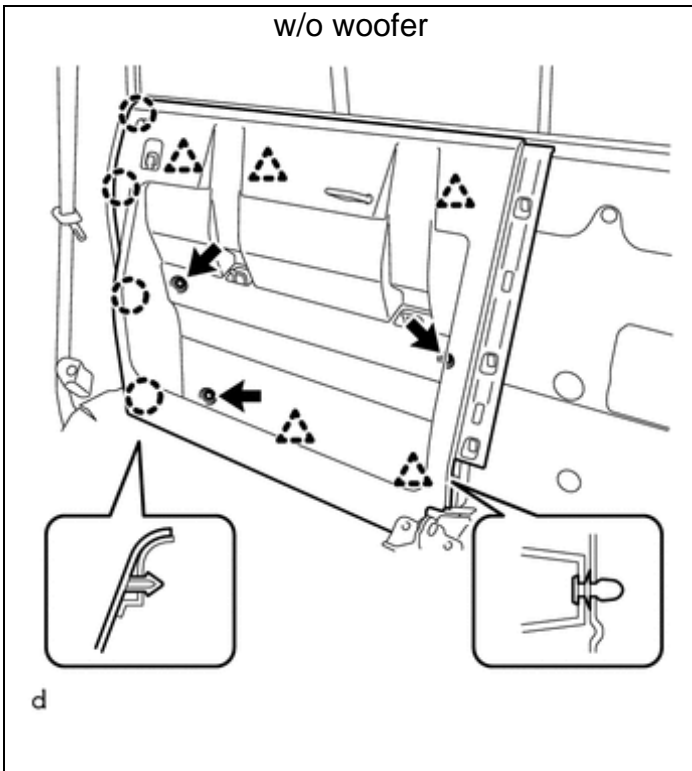

*Note: if you break some clips (90467-09240) during removal (or reinstallation), replacement clips may be ordered and included on the warranty claim. The P/N is 90467-09240.*

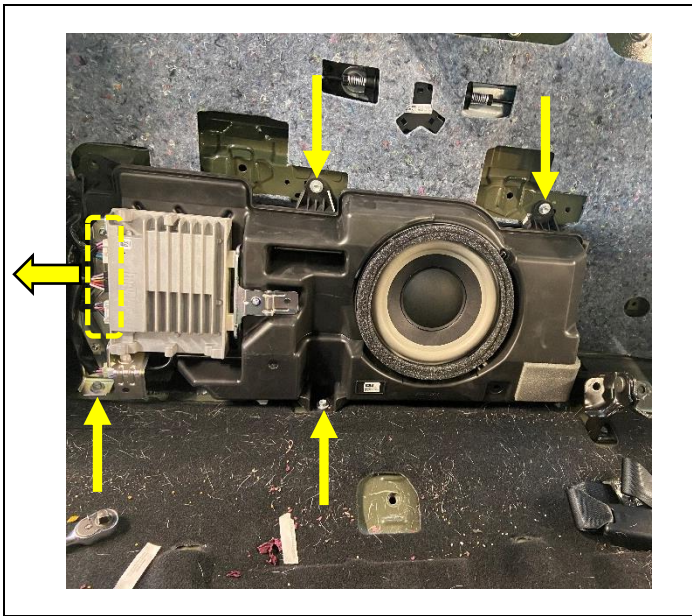

**10. REMOVE SUB-WOOFER AND AMPLIFIER ASSEMBLY (IF EQUIPPED)**

- a. Remove the four (4) bolts as shown in the diagram
- b. Remove the electrical connectors

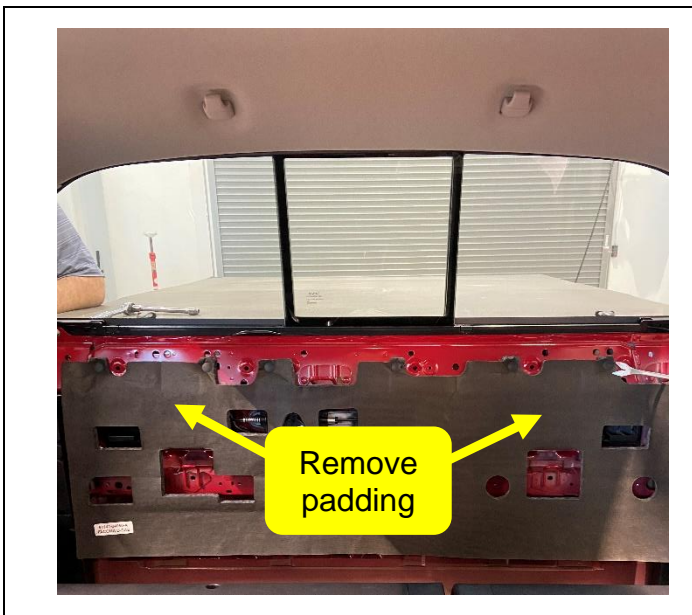

**11. REMOVE PADDING**



## VI. PERFORM CHISEL-CHECK (child seat anchor weld inspection procedure)

**Background:** The chisel-check is an inspection procedure used to confirm if the three (3) factory-welds on each of the three (3) upper child seat anchors have sufficient strength.

◀ CHISEL-CHECK VIDEO INSTRUCTIONS ▶  
(~3 MINUTES)

1. Watch the chisel-check video instructions



You must watch the video for instructions on performing the chisel-check

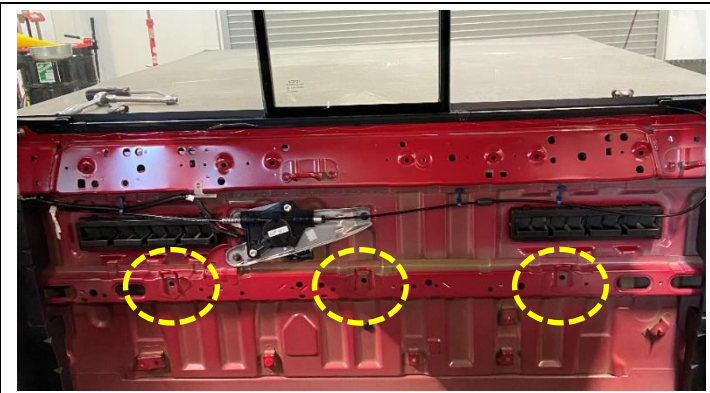

2. Each of the three (3) upper child seat anchors need to be chisel-checked

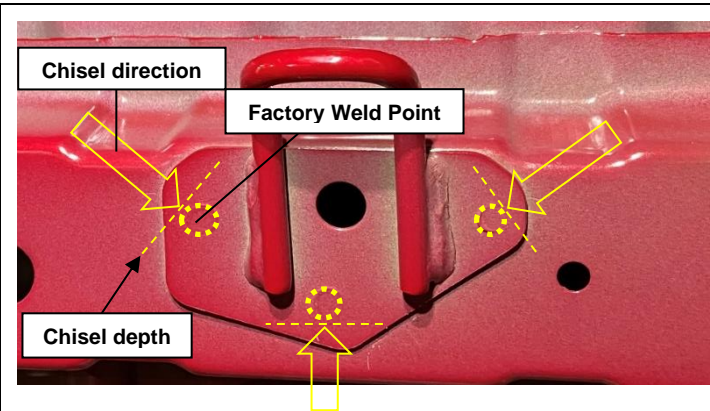

3. This diagram shows the **three (3) factory weld points** on each upper child seat anchor that require the chisel-check, the chisel **depth**, and the chisel **direction**.



- **Stop driving the chisel once it reaches the factory-weld. You don't have to drive the chisel very hard.**
- You are not trying to drive the chisel through the factory-weld. The goal is to drive the chisel just hard enough to **wedge** it between the back panel and the anchor.
- If the factory-weld is bad, the force from the wedging should separate it right away.
- If you drive the chisel too hard, you could accidentally punch a hole with the chisel through the back panel.
- **Do not use an air hammer.**

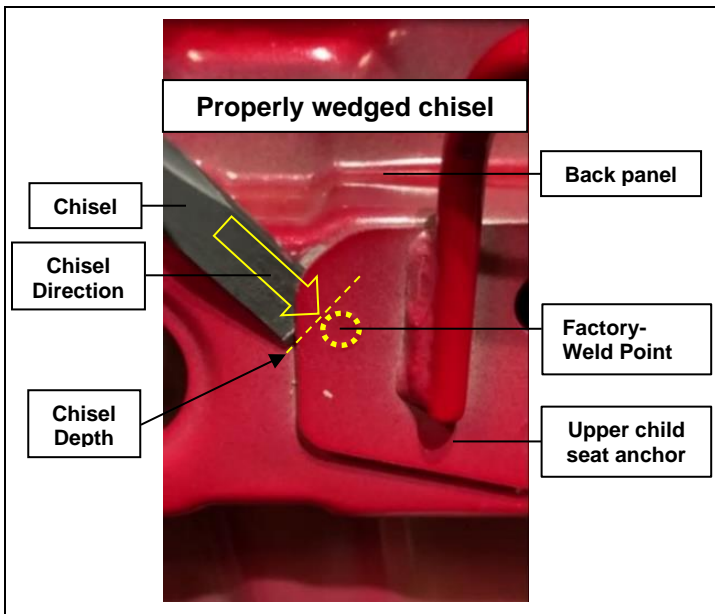

# ◀ CHISEL-CHECK RESULTS ▶

Result

Picture Example

OK

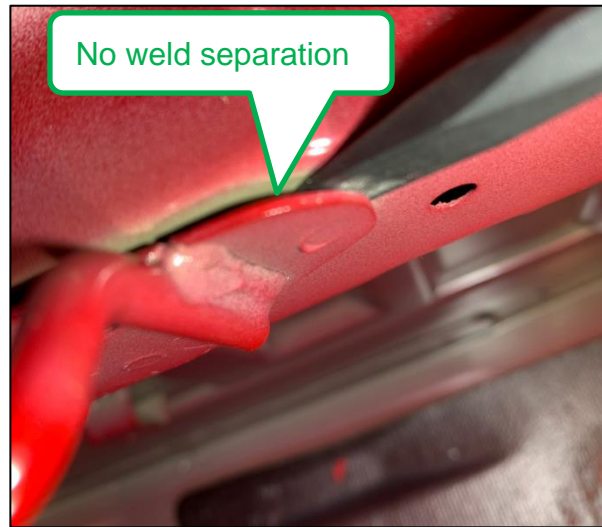

NG

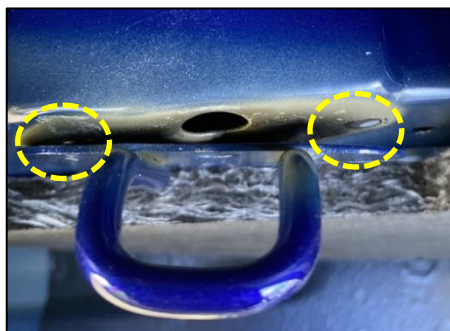
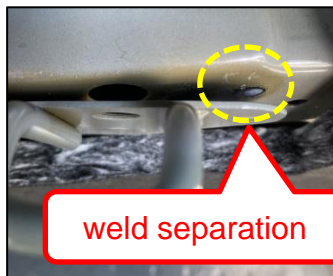

**◀ DID ONE OR MORE OF THE FACTORY WELDS BREAK AFTER THE CHISEL-CHECK? ▶**

Answer	Actions to Take
<p align="center"><b>NO</b> All factory welds are <b>OK</b></p>	<ol style="list-style-type: none"> <li>1. Campaign completed – vehicle is NOT affected.</li> <li>2. Reassemble the vehicle following the instructions in section XVI.</li> <li>3. Return vehicle to customer.</li> </ol>
<p align="center"><b>YES</b> One or more factory welds are broken (<b>NG</b>)</p>	<ol style="list-style-type: none"> <li>1. Afix the <b>DO NOT USE</b> label (page 20 in the appendix) to the <u>affected</u> upper child seat anchor(s) so the body shop knows which anchor(s) to weld.</li> <li>2. Perform the Weld Repair (sections VIII - XIV) to add welds to the affected upper child seat anchor(s).</li> </ol> <p><i>Note: A third-party body shop may be needed to perform the Weld Repair. If so, you MUST SHARE the Weld Repair instructions with the body shop. The Weld Repair instructions are detailed in Sections VIII -XIV in these Technical Instructions.</i></p>



The child seat anchor weld inspection procedure in Section VI **MUST** be performed **FIRST** before performing the weld repair. **ONLY AUTHORIZED TOYOTA DEALERS** are authorized to perform the weld inspection procedure (Section VI).

## VII. OPERATIONAL FLOW CHART (WELD REPAIR)

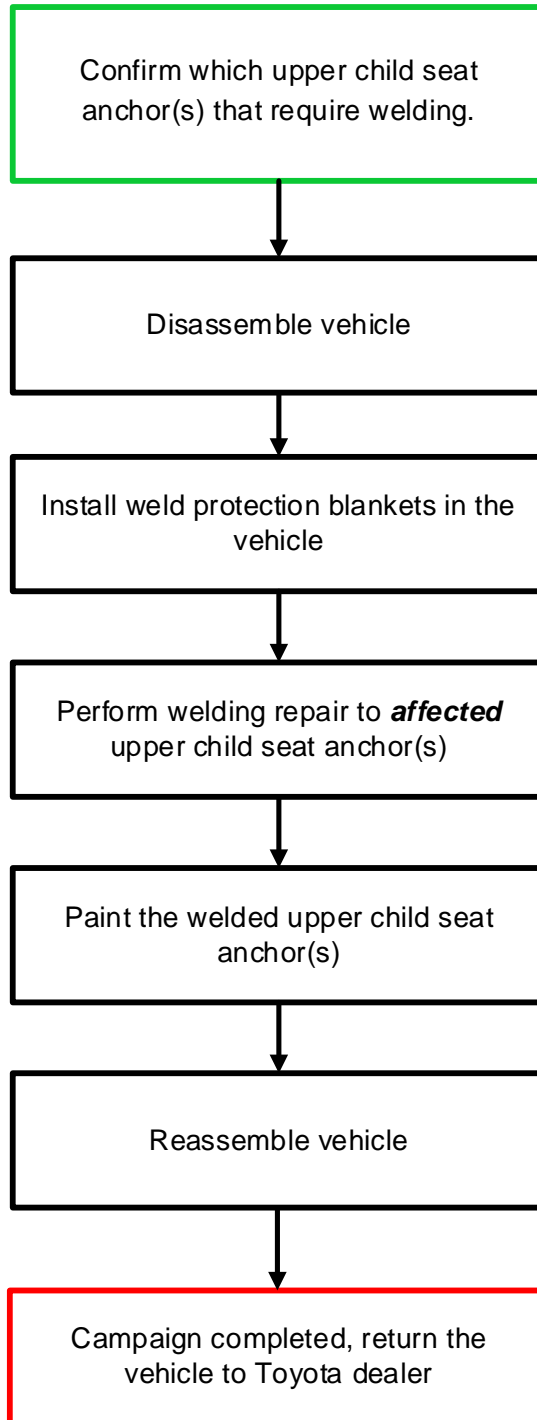

## VIII. BACKGROUND (WELD REPAIR)



### **Background**

You will weld **one or more** of the three (3) upper child seat anchors.



The Toyota dealer should mark the anchor(s) that require welding with a DO NOT USE label. If you cannot determine which anchors require welding, call the Toyota dealer to confirm.

## IX. PREPARATION (WELD REPAIR)

### **B. TOOLS & EQUIPMENT**

- Leather weld protection blankets for vehicle interior (Fiber glass blankets are not recommended)
- MIG weld machine
- Sanding device/tool

### **C. SUPPLIES**

- Weld/spark deflector paper (3M 05916 recommended)
- Tape (3M 301+ recommended)
- Aluminum foil
- Sandpaper/sanding disc
- Paint
- Clear Coat
- 2K Epoxy Primer
- Cavity Wax

## X. CONFIRM UPPER CHILD SEAT ANCHORS TO BE WELDED

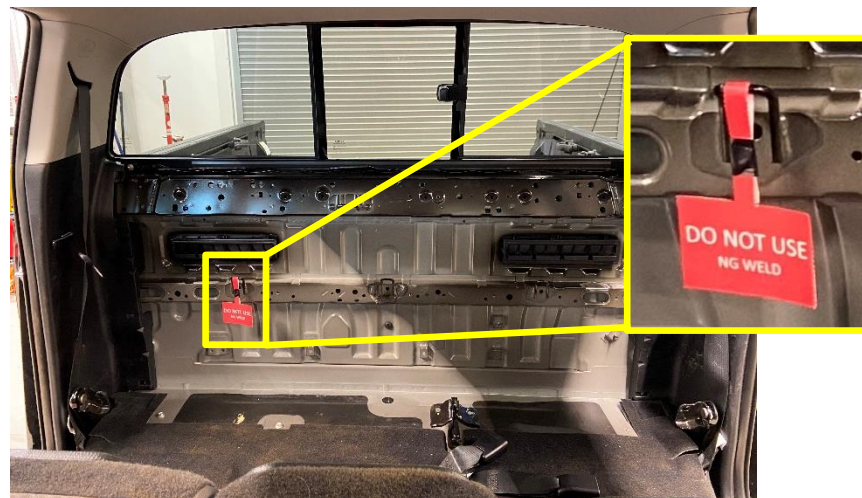

1. The Toyota dealer should have attached a "DO NOT USE" label (shown in the example the left) to the upper child seat anchor(s) that require welding.



Only weld upper child seat anchors that have been marked by the Toyota dealer.



**Make sure you know which upper child seat anchor(s) to weld. If the Toyota dealer has not attached the DO NOT USE label to any anchors, contact the Toyota dealer and request them to specify which anchor(s) require welding.**

## XI. CONFIRM VEHICLE IS DISASSEMBLED

1. Remove negative battery cable
2. Confirm the rear seat area is disassembled.  
The vehicle should be in the following condition once properly disassembled

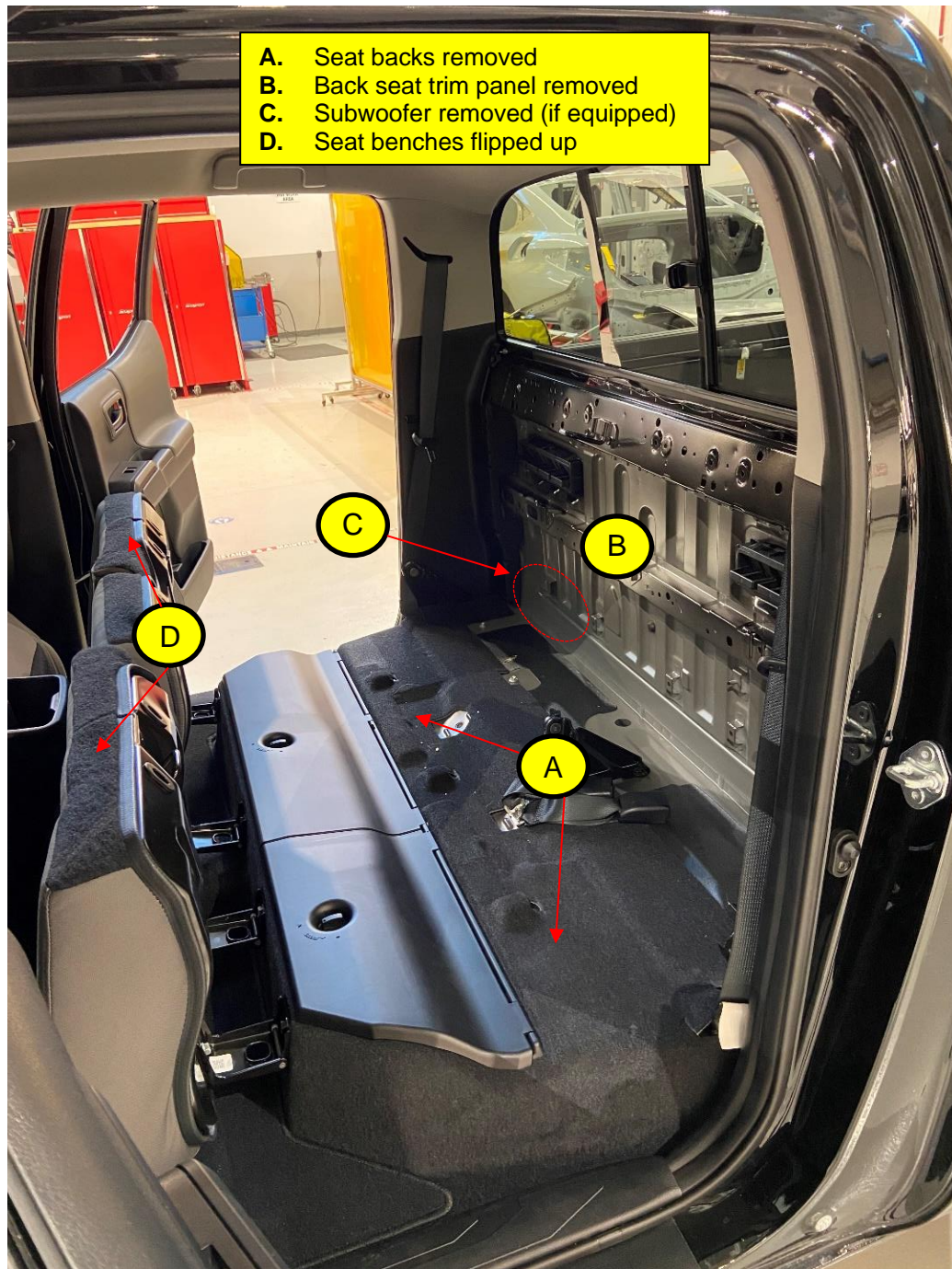

## XII. INSTALL ADEQUATE WELD PROTECTION IN VEHICLE

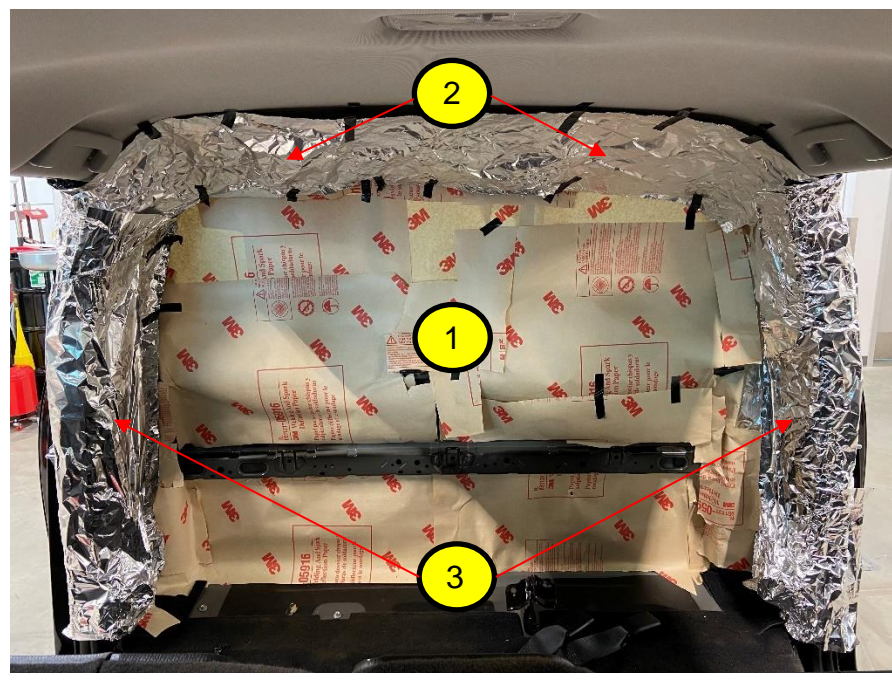

1. Cover the back panel and glass with weld and spark protection paper (3M 05916 or equivalent).

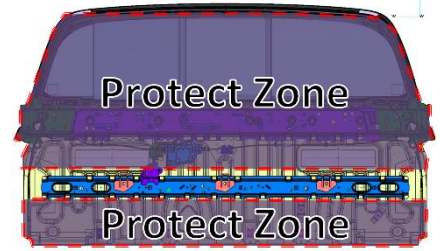

 *Ensure the back glass is thoroughly covered in weld/spark protection paper*

2. Cover the rear end of the headliner with aluminum foil.
3. Cover the hinge pillars and seat belts with aluminum foil or a weld blanket.



4. Protect the floor by installing a leather weld protection blanket.
5. Protect the front seats, and rear seat benches (folded-up), by installing leather weld protection blankets.

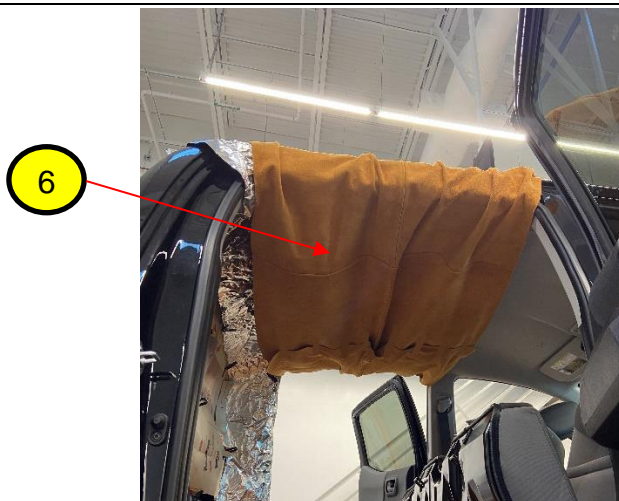

6. Protect the headliner by installing a leather weld blanket as shown in the picture.

### XIII. WELD THE AFFECTED CHILD SEAT ANCHOR



**Make sure you know which upper child seat anchor(s) to weld. If the Toyota dealer has not attached the DO NOT USE label to any anchors, contact the Toyota dealer and request them to specify which anchor(s) require welding.**

Sand the Anchor

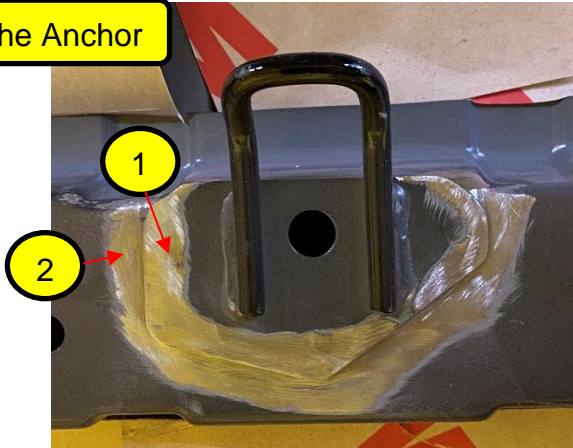

1. Sand the perimeter of the back panel surrounding the child seat anchor
2. Sand the perimeter of the upper child seat anchor(s) that requires welding.

Ground Clamp

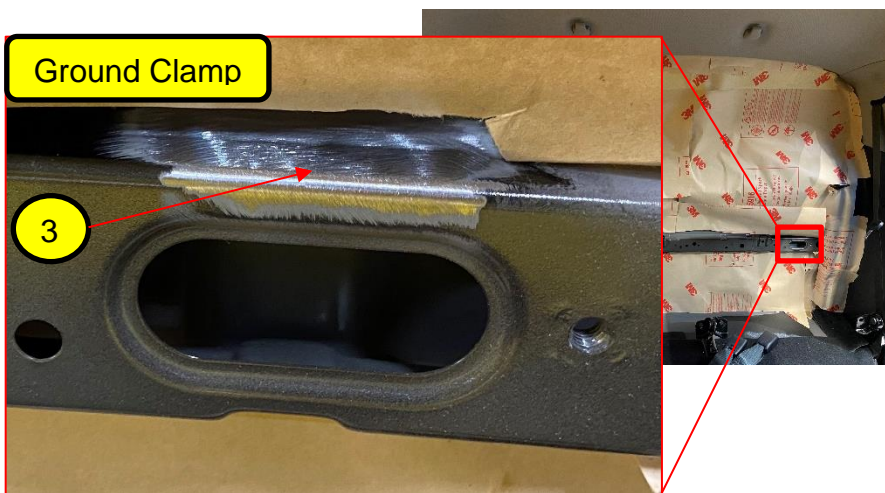

3. It's recommended to attach the ground clamp to one of the holes in the brace as shown in the picture.
  - a.) You will need to sand the surface to get sufficient conductance.
  - b.) Repaint and clear coat the area that you sand when finished.

Weld Areas

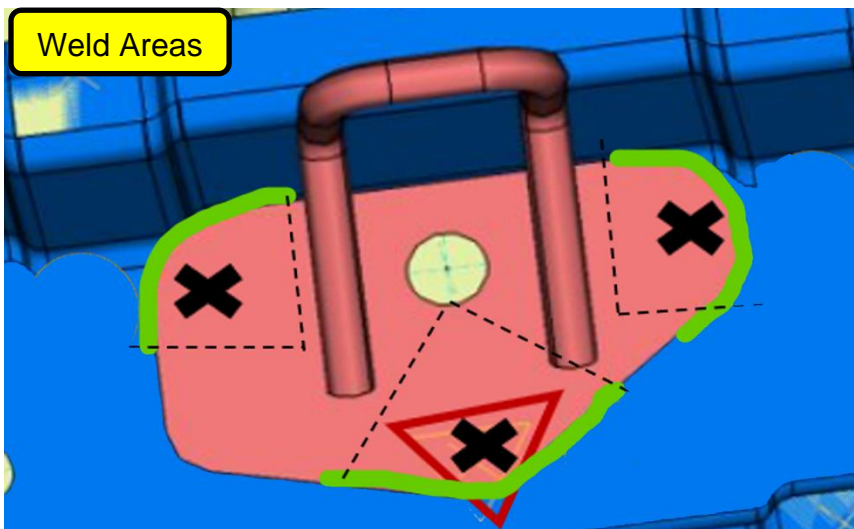

4. Apply MIG welding to the three (3) areas shown in **green** the diagram



**Important:** Even if only 1 factory-weld is broken, you must weld all 3 areas shown in the diagram



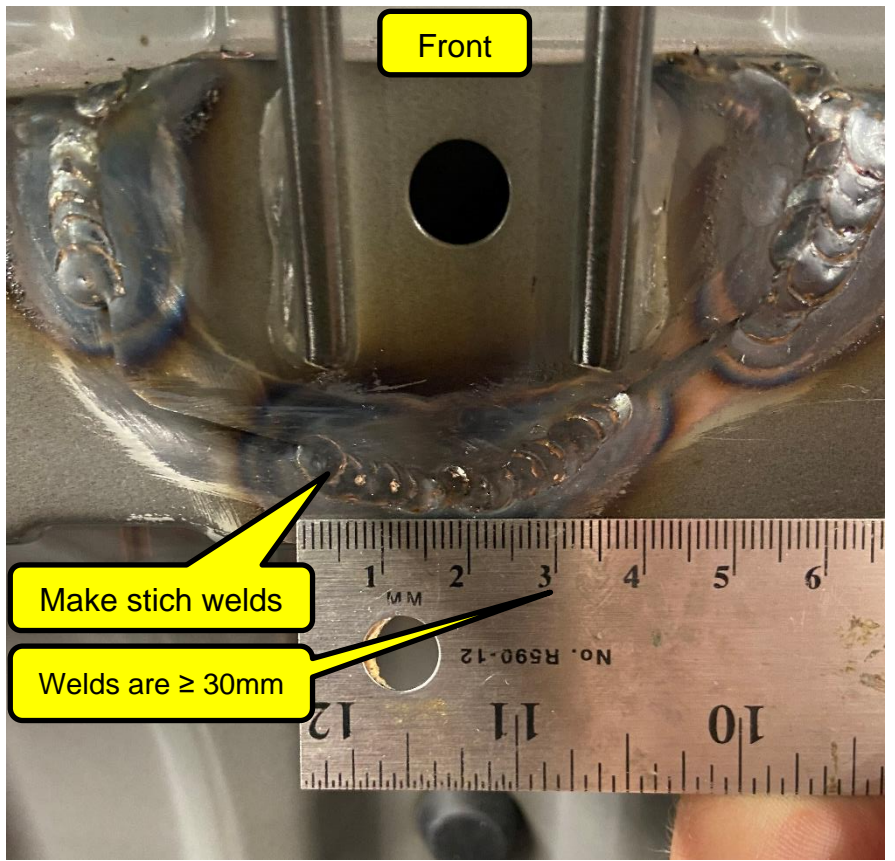

5. Weld Instructions

- Make stich-welds (not continuous beads)
- The minimum length of the welds should be 30 mm
- To confirm correct penetration and settings, perform a practice-weld on spare metal

The thicknesses of the factory-metals are shown below for your reference:

Child anchor thickness  $\rightarrow 1.4\text{ mm}$   
 Back panel thickness  $\rightarrow 0.6\text{ mm}$

 Ensure your practice welds are similar to the welds shown in these pictures

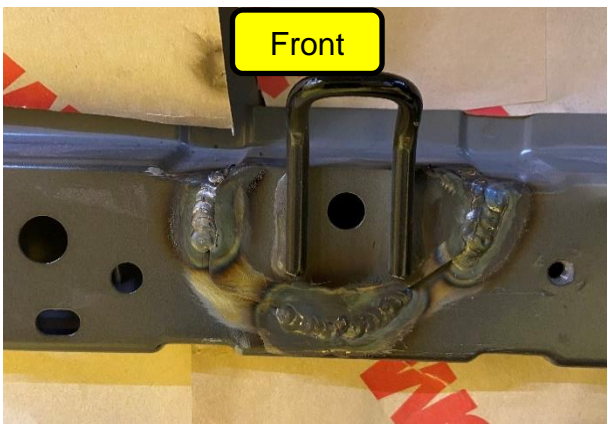
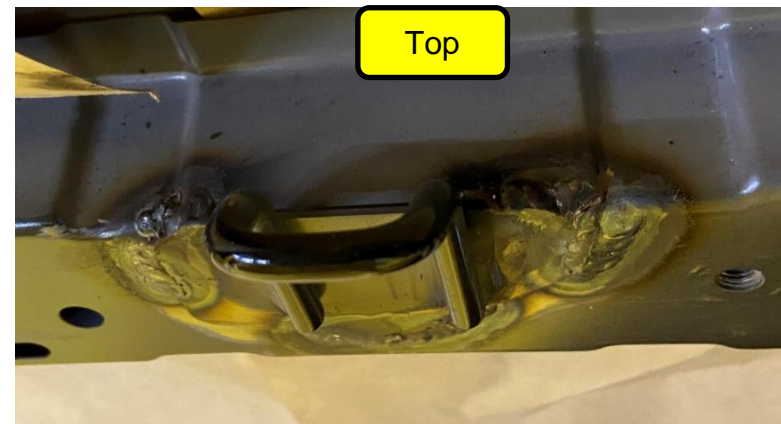
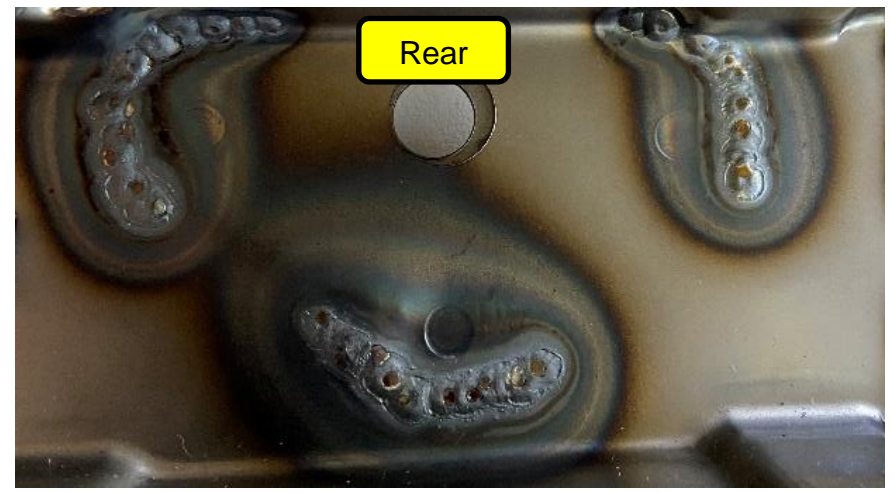

#### XIV. PAINT THE WELDED ANCHORS



1. Repaint and clear-coat the welded anchor(s).
2. Repaint and clear-coat the sanded area for the ground clamp.
3. Apply cavity wax to the back side of the welded anchors.

*Note: When repainting the welded anchors, Toyota recommends using a high quality 2K epoxy primer.*

#### XV. CONFIRM BODY SHOP WELDS ARE PRESENT

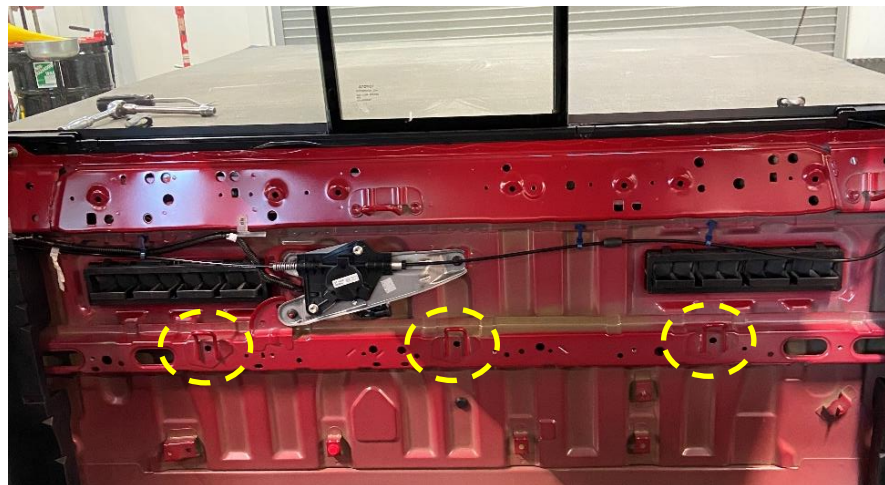

1. **CONFIRM THAT THE BODY SHOP WELDED THE CORRECT ANCHOR(S)**

You should be able to visually inspect the child seat anchors to make sure the body shop welded the correct anchor(s)



**If the body-shop failed to weld one or more of the NG anchors identified during the inspection procedure in Section VI, those NG anchors needed to be welded. Notify the body shop.**

2. **CONFIRM THAT THE DEALER TECHNICIAN DID NOT FORGET TO TAG NG ANCHOR(S) IN SECTION VI.**

You should be able to visually inspect the child seat anchors to make sure there are no broken welds on any anchors.



**If you identify a broken weld, it needs to be welded using the welding process in Section XIII**

## XVI. REASSMBLE VEHICLE



**Make sure all NG upper child seat anchor(s) have the weld repair performed before resassembling the vehicle and returning to customer**

### NOTES:

- The paint on the back panel and anchor may scratch from the chisel check. This is OK, and scratches do not need to be repainted
- After the chisel-check, the anchor may no longer be flush with the back panel. For this case, you may use a hammer to flatten the anchor so that its flush with the back panel.

1. Reinstall the padding
2. Reinstall sub-woofer and applifier assembly (if equipped)
  - **Torque: 8.4 N m (86 kgf cm, 74 in lbf)**
3. Reinstall luggage compartment side tray RH
4. Reinstall luggage compartment side tray LH
5. Reinstall seat back assembly
  - **Torque: 37 N m (377 kgf cm, 27 ft lbf)**
6. Reinstall the bolt into the floor for the middle seat belt
  - **Torque: 42 N m (428 kgf cm, 31 ft lbf)**



Make sure that the rear seat inner belt assembly and rear center seat outer belt assembly is oriented in the correct direction when installing. Refer to the diagram below.

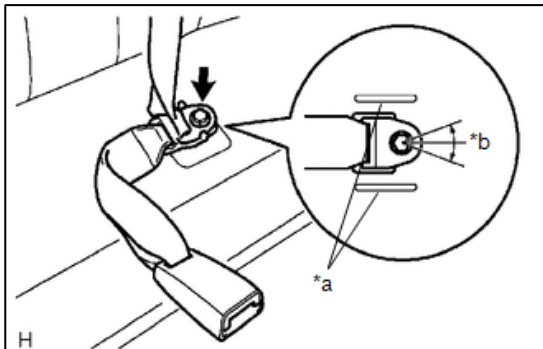

*a	Protuding part of floor
*b	40°

7. Flip the seat bench down
8. Reinstall the headrests
9. Reinstall the negative battery cable
  - **Torque: 5.4 N m (55 kgf cm, 48 in lbf)**

## ◀ VERIFY REPAIR QUALITY ▶

- **Confirm applicable initializations have been performed.**
- **If you have any questions about the results of your chisel check, you may discuss them with your FTS.**

Safety Recall 22TA09 – “Do Not Use Label”

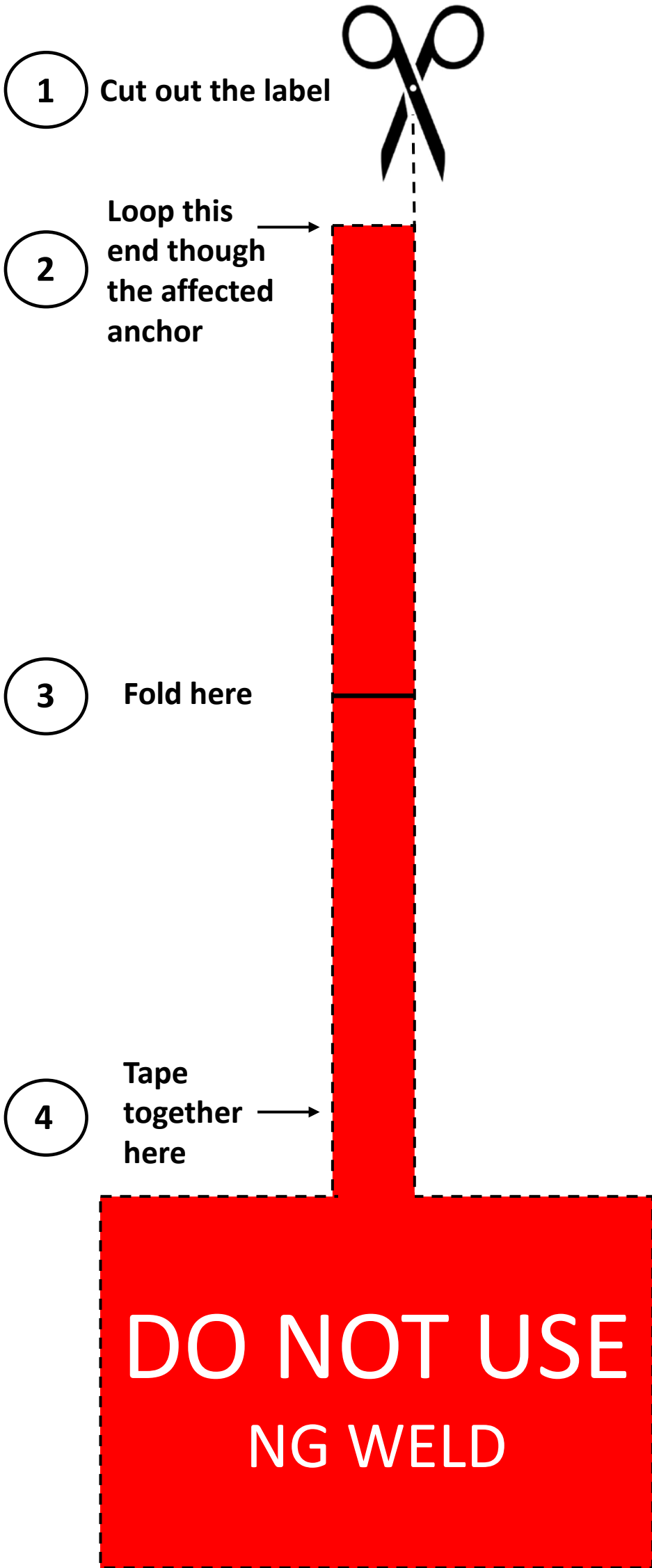

## Example of a properly affixed label

**NOTE: ONLY ATTACH THIS LABEL TO AFFECTED ANCHOR(S)**

**This example depicts the label attached to the right upper child seat anchor. Its possible that up to ALL THREE (3) of the upper child seat anchors are affected (have one or more bad factory-welds) and thus, require this label affixed.**

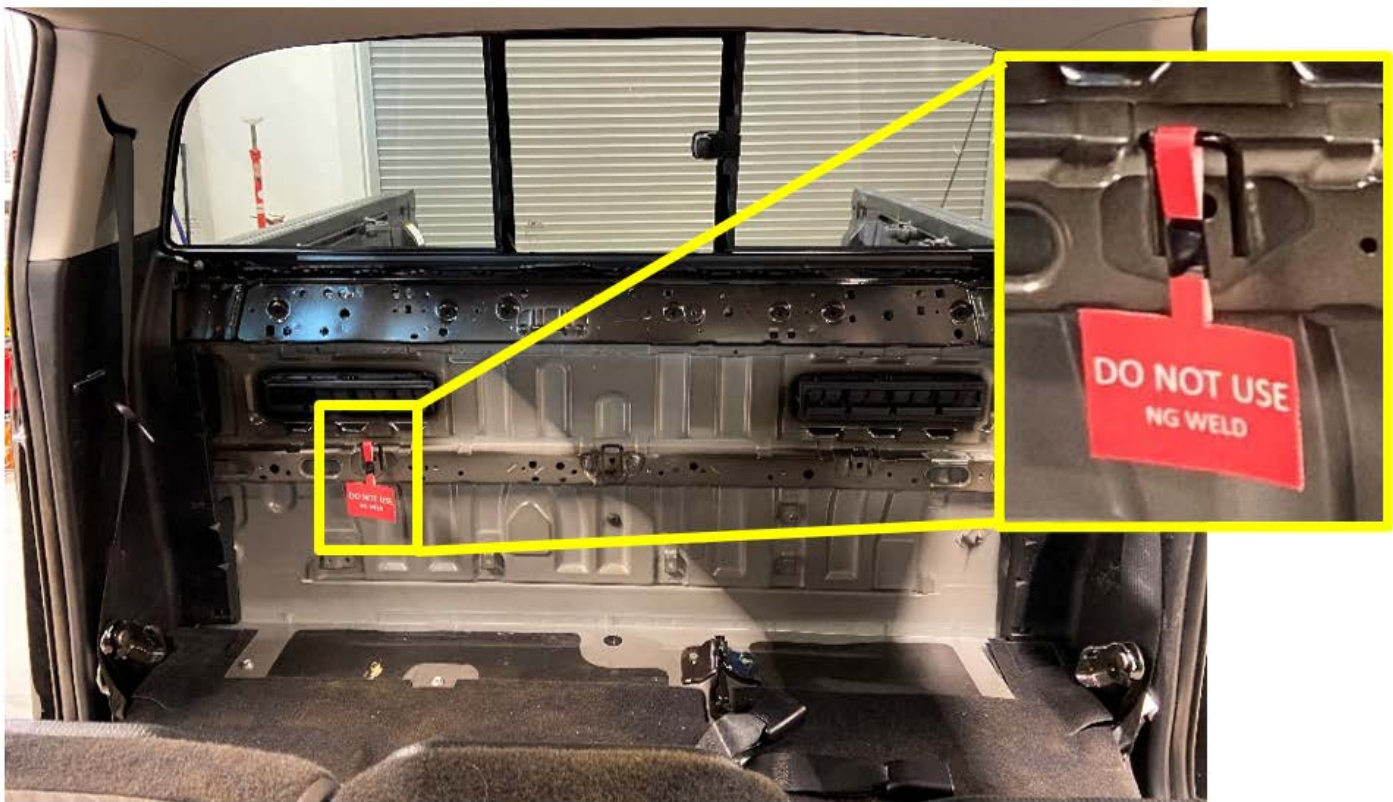

# Campaign Designation / Phase Decoder

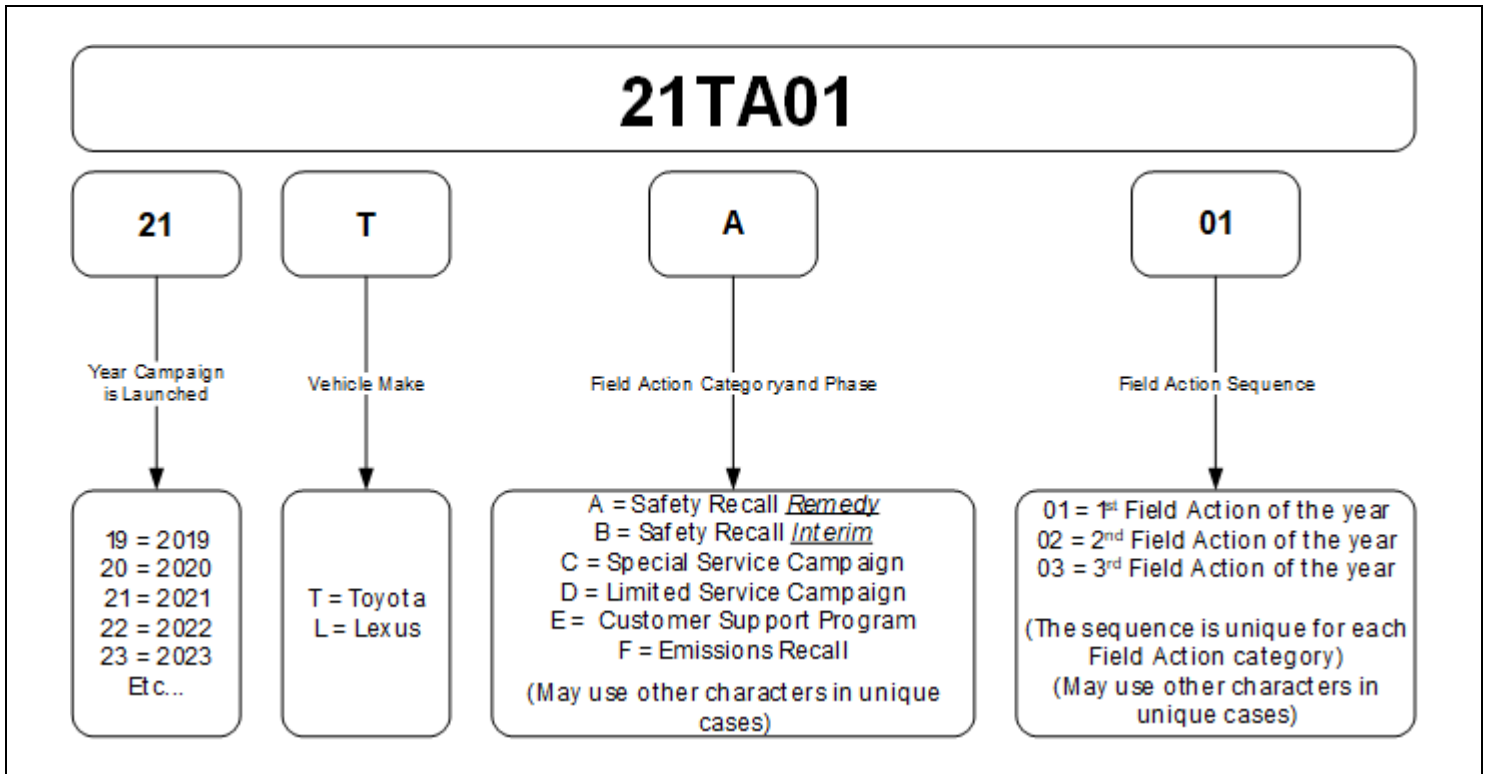

**Examples:**

19TA01 = Launched in 2019, Toyota, Safety Recall Remedy Phase, 1st Safety Recall Launched in 2019

20TC02 = Launched in 2020, Special Service Campaign, 2nd Special Service Campaign Launched in 2020

21TE05 = Launched in 2021, Customer Support Program, 5th Customer Support Program Launched in 2021