

Safety Recall

Code: 20DR



Audi

REVISION

Subject Fuel Pump

Revision Date March 15, 2023

REVISION SUMMARY Updated claiming with additional labor operation

Affected Vehicles

Country	Beginning Model Year	Ending Model Year	Vehicle	Vehicle Count
USA	2020	2021	Q7	19,031
USA	2019	2021	Q8	30,412
CAN	2020	2021	Q7	2,356
CAN	2019	2021	Q8	3,744

Check Campaigns/Actions screen in Elsa on the day of repair to verify that a VIN qualifies for repair under this action. Elsa is the only valid campaign inquiry & verification source.

- ✓ Campaign status must show "open."
- ✓ If Elsa shows other open action(s), inform your customer so that the work can also be completed at the same time the vehicle is in the workshop for this campaign.

Problem Description

A component of the fuel delivery module inside the fuel tank may break while operating the vehicle. The fragments can damage the sealing membrane in the pressure regulator. This may lead to a failure of the fuel delivery module and the instrument cluster will display the Malfunction Indicator Light (MIL). In rare cases and under certain circumstances, however, there may be a sudden loss of engine power or the vehicle may break down without a warning appearing beforehand. A fuel leak due to this failure can be ruled out.

Corrective Action

Replace the fuel delivery module.

Precautions

This issue may cause the Malfunction Indicator Light (MIL) to illuminate. If this happens, owners are advised to contact an authorized Audi dealer without delay to have the vehicle diagnosed/repared.

Code Visibility

On July 28, 2022, the campaign code was applied to affected vehicles.

Owner Notification

Owner notification took place in December 2022. Owner letter examples are included in this bulletin for your reference.

Additional Information

Please alert everyone in your dealership about this action, including Sales, Service, Parts and Accounting personnel. Contact Warranty if you have any questions.

IMPORTANT REMINDER ON VEHICLES AFFECTED BY SAFETY & COMPLIANCE RECALLS

New Vehicles in Dealer Inventory: It is a violation of federal law for a dealer to deliver a new motor vehicle or any new or used item of motor vehicle equipment (including a tire) covered by this notification under a sale or lease until the defect or noncompliance is remedied. By law, dealers must correct, prior to delivery for sale or lease, any vehicle that fails to comply

with an applicable Federal Motor Vehicle Safety Standard or that contains a defect relating to motor vehicle safety.

Pre-Owned Vehicles in Dealer Inventory: Dealers should not deliver any pre-owned vehicles in their inventory which are involved in a safety or compliance recall until the defect has been remedied.

Dealers must ensure that every affected inventory vehicle has this campaign completed before delivery to consumers.

Parts Information

Parts Control Type:
Upper Order Limit

Parts will be managed with a weekly Upper Order Limit. Please see Parts On Command (POC) for your Upper Order Limit quantity.

Initial Allocation:
NO

There will be no parts allocation. Please reference the Repair Projection Tool (below) to view your potential VIN population.

Repair Projection Tool:
(right click to open)



Criteria	Quantity	Part Number	P.O.C. Part Description	Ordering Method
ALL	1	4M0-919-087-F	MODULE	UOL
	1	1J0-919-133-B	WASHER	UOL

NOTE

The specified part numbers reflect the status at the start of this action. Interim updates made in ETKA can cause a listed part number to become unavailable. In this case, the new part number specified in ETKA should be used.

Claim Entry Instructions

The labor times listed here may differ from the labor operations and labor times listed in ELSA.

After campaign has been completed, enter claim as soon as possible to help prevent work from being duplicated elsewhere. Attach the Elsa screen print showing action open on the day of repair to the repair order.

If customer refused campaign work:

- ✓ U.S. dealers: Submit the request through Audi Warranty Online under the Campaigns/Update option.
- ✓ Canada dealers: Upload the repair order [signed by customer] to Audi WIN/Operations/Campaign Closure.

Service Number	20DR
Damage Code	0099
Parts Vendor Code	002
Claim Type	Sold vehicle: 7 10 Unsold vehicle: 7 90
Causal Indicator	Mark MODULE* as causal part
Vehicle Wash/Loaner	Do not claim wash/loaner under this action

Vehicles will have more than one criteria. Complete and claim all applicable criteria on one claim.

Criteria I.D.	01 and 03 (Q7) OR 02 and 03 (Q8)		
	LABOR		
	Labor Op	Time Units	Description
	2066 19 50	SEE ELSA	Electric fuel pump remove+reinstall
	2070 19 00	SEE ELSA	Fuel pump control module remove+reinstall
	9310 83 60	SEE ELSA	Disable HV system voltage deactivate and activate (if equipped)
	2003 17 50	SEE ELSA	Fuel drain+fill (If necessary)
	1083 19 50	SEE ELSA	Cover remove+reinstall (If necessary)
	2706 89 50	10	Connect battery charger
	0151 00 00	Time stated on diagnostic protocol	GFF Operations (if necessary)
	PARTS		
	Quantity	Part Number	Description
	1.00	4M0919087F	MODULE*
	1.00	1J0919133B	WASHER
	Up to 2.00	4M8886373	GROMMET (Q8 ONLY - if necessary)

The repair information in this document is intended for use only by skilled technicians who have the proper tools, equipment and training to correctly and safely maintain your vehicle. These procedures are not intended to be attempted by "do-it-yourselfers," and you should not assume this document applies to your vehicle, or that your vehicle has the condition described. To determine whether this information applies, contact an authorized Audi dealer. ©2023 Audi of America, Inc. and Audi Canada. All Rights Reserved.

Customer Letter Example (USA)

<MONTH YEAR>

<CUSTOMER NAME>

<CUSTOMER ADDRESS>

<CUSTOMER CITY STATE ZIPCODE>

This notice applies to your vehicle: <MODEL YEAR> <BRAND> <CARLINE>, <VIN>

NHTSA: 22V516

Subject: Safety Recall 20DR – Fuel Pump

Dear Audi Owner,

This notice is sent to you in accordance with the National Traffic and Motor Vehicle Safety Act. Audi has decided that a defect, which relates to motor vehicle safety, exists in certain 2019-2021 model year Audi vehicles. Our records show that you are the owner of a vehicle affected by this action.

What is the issue? A component of the fuel delivery module inside the fuel tank may break while operating the vehicle. The fragments can damage the sealing membrane in the pressure regulator. This may lead to a failure of the fuel delivery module and the instrument cluster will display the Malfunction Indicator Light (MIL). In rare cases and under certain circumstances, however, there may be a sudden loss of engine power or the vehicle may break down without a warning appearing beforehand. A fuel leak due to this failure can be ruled out.

What will we do? To correct this defect, your authorized Audi dealer will replace the fuel delivery module. This work will take up to a day to complete and will be performed for you free of charge. Please keep in mind that your dealer may need additional time for the preparation of the repair, as well as to accommodate their daily workshop schedule.

What should you do? Please contact your authorized Audi dealer without delay to schedule this recall work. For your convenience, you can also visit www.audiusa.com and click on the "Find a Dealer" link to locate a dealer near you and schedule this service.

Precautions you should take This issue may cause the Malfunction Indicator Light (MIL) to illuminate. If this happens, owners are advised to contact an authorized Audi dealer without delay to have the vehicle diagnosed/repared.

Lease vehicles and address changes If you are the lessor and registered owner of the vehicle identified in this action, the law requires you to forward this letter immediately via first-class mail to the lessee within ten (10) days of receipt. If you have changed your address or sold the vehicle, please fill out the enclosed prepaid Owner Reply card and mail it to us so we can update our records.

Can we assist you further? If your authorized Audi dealer fails or is unable to complete this work free of charge within a reasonable time, please contact Audi Customer Experience at 1-800-253-2834 or via our "Contact Us" page at www.audiusa.com.

Checking your vehicle for open Recalls and Service Campaigns To check your vehicle's eligibility for repair under this or any other recall/service campaign, please visit the **Recall/Service Campaign Lookup** tool at www.audiusa.com and enter your Vehicle Identification Number (VIN).

If you still cannot obtain satisfaction, you may file a complaint with: The Administrator, National Highway Traffic Safety Administration, 1200 New Jersey Avenue, SE., Washington, DC 20590; or call the toll-free Vehicle Safety Hotline at 1-888-327-4236 (TTY: 1-800-424-9153); or go to <http://www.safercar.gov>.

We apologize for any inconvenience this matter may cause; however we are taking this action to help ensure your safety and continued satisfaction with your vehicle.

Sincerely,

Audi Customer Protection

Customer Letter Example (Canada)

<MONTH YEAR>

<CUSTOMER NAME>

<CUSTOMER ADDRESS>

<CUSTOMER CITY STATE ZIPCODE>

This notice applies to your vehicle: <MODEL YEAR> <BRAND> <CARLINE>, <VIN>

Transport Canada Recall: 2022-384

Subject: Safety Recall 20DR – Fuel Pump

Dear Audi Owner,

This notice is sent to you in accordance with the requirements of the *Motor Vehicle Safety Act*. This is to inform you that your vehicle may contain a defect that could affect the safety of a person. Our records show that you are the owner of a vehicle affected by this action.

- What is the issue?** A component of the fuel delivery module inside the fuel tank may break while operating the vehicle. The fragments can damage the sealing membrane in the pressure regulator. This may lead to a failure of the fuel delivery module and the instrument cluster will display the Malfunction Indicator Light (MIL). In rare cases and under certain circumstances, however, there may be a sudden loss of engine power or the vehicle may break down without a warning appearing beforehand. A fuel leak due to this failure can be ruled out.
- What will we do?** To correct this defect, your authorized Audi dealer will replace the fuel delivery module. This work will take up to a day to complete and will be performed for you free of charge. Please keep in mind that your dealer may need additional time for the preparation of the repair, as well as to accommodate their daily workshop schedule.
- What should you do?** Please contact your authorized Audi dealer without delay to schedule this recall work.
- Precautions you should take** This issue may cause the Malfunction Indicator Light (MIL) to illuminate. If this happens, owners are advised to contact an authorized Audi dealer without delay to have the vehicle diagnosed/repared.
- Lease vehicles and address changes** If you are the lessor and registered owner of the vehicle identified in this letter, you shall forward this letter (and any subsequent notice, if applicable) to the lessee within ten (10) days of receipt. If you have changed your address or sold the vehicle identified in this letter, please fill out the enclosed prepaid Owner Reply Card and mail it to us so we can update our records.
- Can we assist you further?** If your authorized Audi dealer fails or is unable to complete this work free of charge within a reasonable time, please contact Audi Customer Relations Monday through Friday from 8AM to 8PM EST at 1-800-822-2834 or via our “Contact Audi Canada” page at www.audi.ca.

We apologize for any inconvenience this matter may cause; however we are taking this action to help ensure your safety and continued satisfaction with your vehicle.

Sincerely,

Audi Customer Protection

Repair Overview

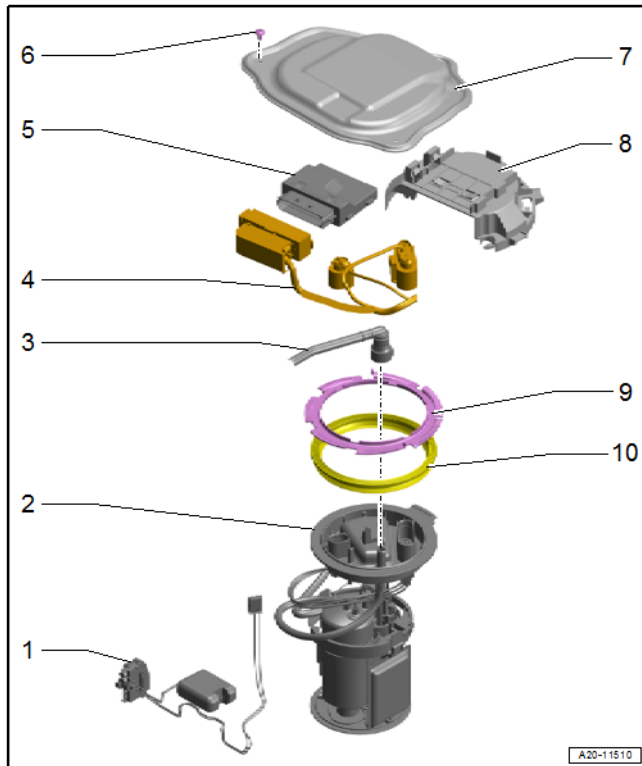







- Replace in-tank fuel delivery unit.

NOTE

- These repair instructions may differ from the labor operations and labor times listed in ELSA.
- Damages resulting from improper repair or failure to follow these work instructions are the dealer's responsibility and are not eligible for reimbursement under this action.
- This procedure must be read in its entirety prior to performing the repair.
- Due to variations in vehicle equipment and options, the steps/illustrations in this work procedure may not identically match all affected vehicles.
- Diagnosis and repair of pre-existing conditions in the vehicle are not covered under this action.
- When working during extreme temperatures, it is recommended that the vehicle be allowed to acclimate inside the shop to avoid temperature-related component damage/breakage.

Required Tools

 <p>Wrench - Fuel Sending Unit -T10202-</p>	 <p>Hook -T10538-</p>
 <p>Universal Vehicle Protector -VAS871001- (or equivalent)</p>	 <p>Pry lever -80-200- (or equivalent)</p>
 <p>Omega Clip Tool -T40280- (or equivalent)</p>	 <p>Scraper Set -VAS6845-</p>
 <p>High Voltage Tool Set - Cable Covers -VAS6762/10- (or equivalent)</p>	

Repair Instruction

Section A - Check for Previous Repair

Applicable criteria ID(s)	Campaign/Action Status
01 ← 2	Open ← 1

EXAMPLE

Campaign/Action	Start	Designation
← 3 →	2015-11-10	W-SERV_ACT -
	2018-12-13	RECALL -
	2017-05-16	A-RECALL -

EXAMPLE

- Enter the VIN in Elsa and proceed to the “Campaign/Action” screen.

TIP

On the date of repair, print this screen and keep a copy with the repair order.

- Confirm the Campaign/Action is open <arrow 1>. If the status is closed, no further work is required.
- Note the Applicable Criteria ID <arrow 2> for use in determining the correct work to be done and corresponding parts associated.

CRITICAL REPAIR STEP

 **STOP!** 

If multiple software update Campaign/Actions are open, they must be performed in order of the Start date <arrow 3>. The oldest should be performed first.

- **All Safety Recalls must be completed prior to completing this campaign.**
- **Proceed to Section B.**

Section B – Repair Preparations



Drain fuel tank:

- Check the vehicle fuel level displayed on the instrument cluster.
- Record the vehicle fuel level on the repair order.
- See ELSA Repair Manual: *Repair Manual > Engine > 20 Fuel Supply > Fuel Tank > Fuel Tank, Draining*

CAUTION

The fuel filler cap must be removed before draining the fuel tank.

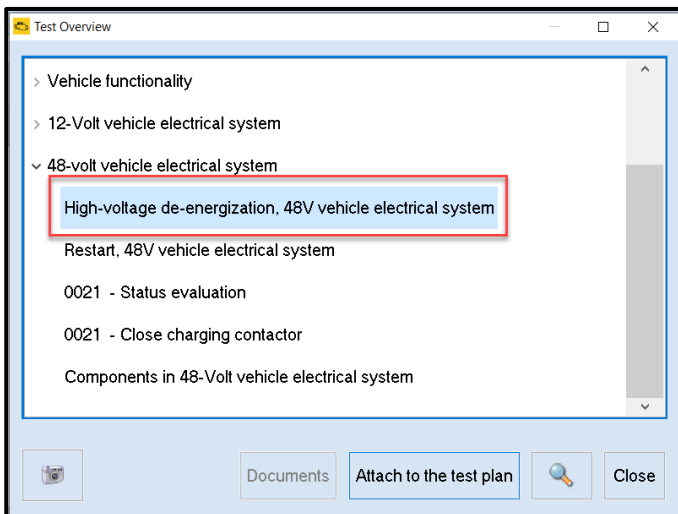

De-energize 48V system (if equipped):

- Select test plan “*High-voltage de-energization, 48V vehicle electrical system.*”
- Follow the ODIS test plan steps.

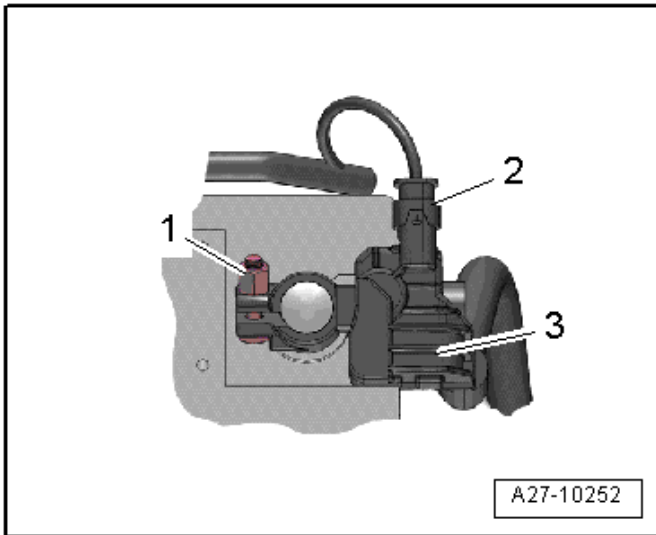

Disconnect 12V battery:

- Move front seats all the way forward.
- See ELSA Repair Manual: *Repair manual > Electrical System > Electrical Equipment > 27 Battery, Starter, Generator, Cruise Control > Battery, Disconnecting and Connecting*

See Section C for fuel delivery unit replacement steps.

See Section D for disassembly and reassembly steps for Q8 models.

See Section E for disassembly and reassembly steps for Q7 models.

Section C – Replacing Fuel Delivery Unit

NOTE

Sections D and E include the disassembly and reassembly steps for each model, Q7 and Q8.

These steps are also outlined in the ELSA Repair Manual.

Reference: *Repair Manual > Engine > Fuel Supply - Gasoline Engines > 20 Fuel Supply > Fuel Delivery Unit/Fuel Level Sensor > Fuel Delivery Unit/Fuel Level Sensor, Removing and Installing*

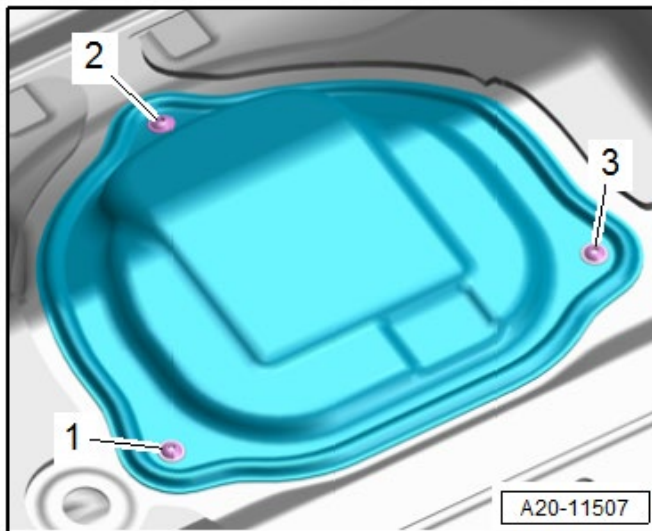

Remove fuel delivery unit cover:

- Remove bolts <1, 2 and 3> and remove the fuel delivery unit cover.

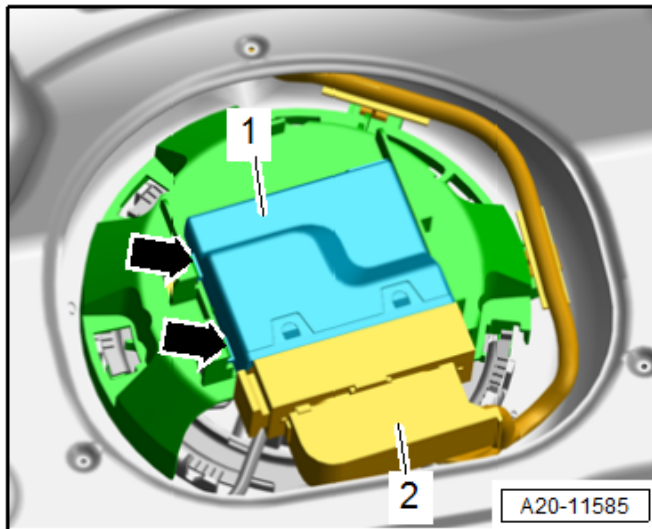

Remove fuel pump control module:

- Release the catches <arrows> using a screwdriver and remove the Fuel Pump Control Module -J538- <item 1> from the bracket.
- Release and disconnect the connector <2> for the Fuel Pump Control Module -J538-.

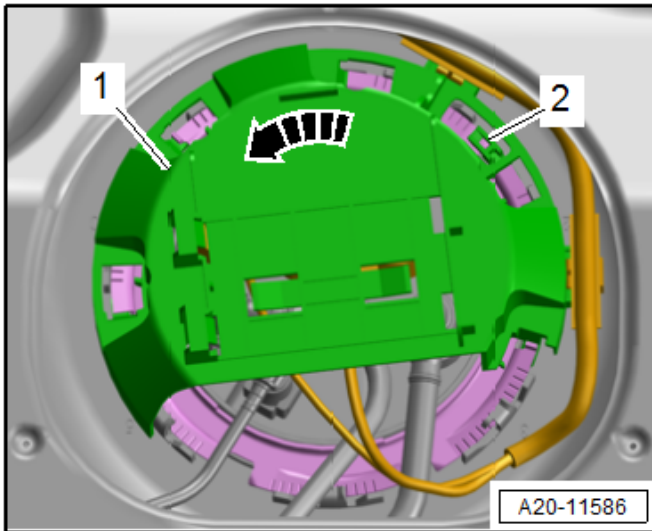

Remove fuel pump control module bracket:

- Release the catch <2> with a screwdriver and turn the bracket <1> for the Fuel Pump Control Module -J538- counter-clockwise <arrow>.
- Disengage the bracket at the locking ring and remove.

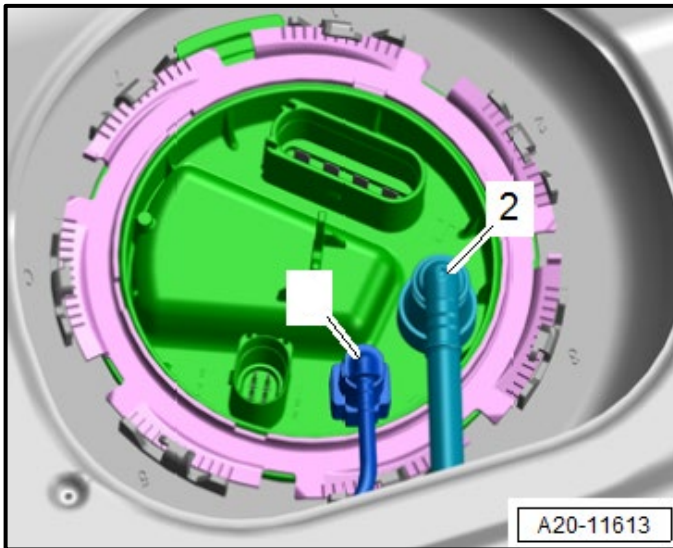

Disconnect electrical connector and fuel lines:

- Unlock the safety catch and disconnect the electrical connectors.
- Press the release button and disconnect the fuel line <2> from the sealing flange.

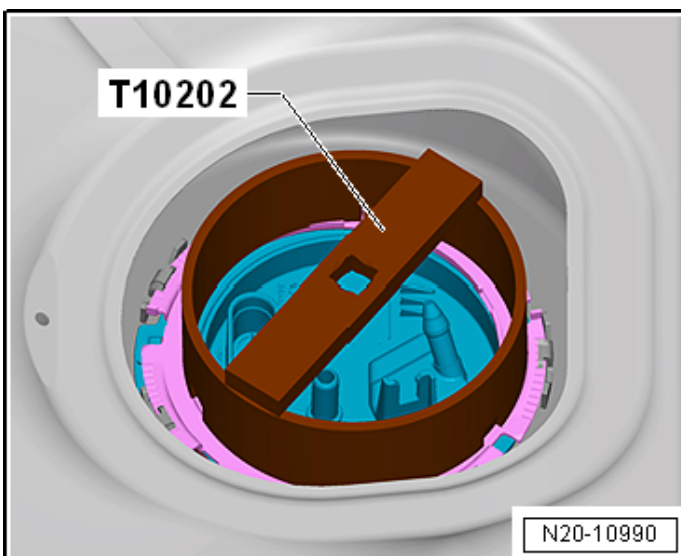

Remove locking ring:

CAUTION

Risk of a fire due to leaking fuel.

Leaking fuel may ignite and start a fire.

Drain the fuel tank when working on the fuel system.

- Remove the locking ring using the Wrench - Fuel Sending Unit -T10202-.

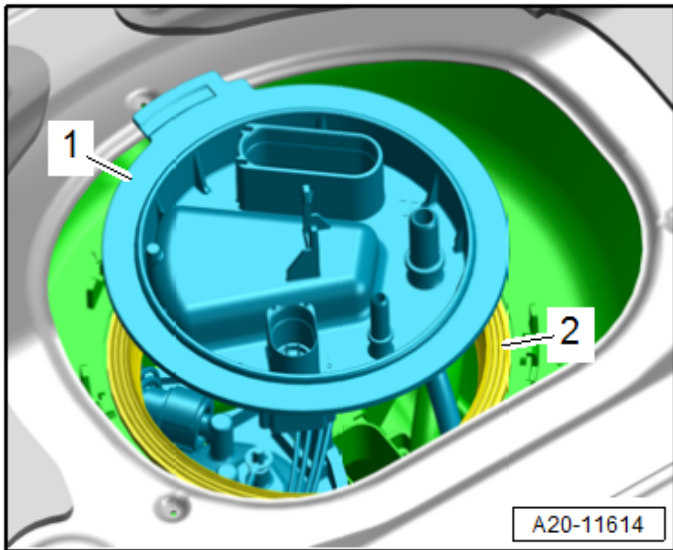

Remove sealing flange:

- Pull the sealing flange <1> slightly out of the fuel tank opening and remove the seal <2>.
- Carefully pull the sealing flange with the fuel lines out of the fuel tank opening.

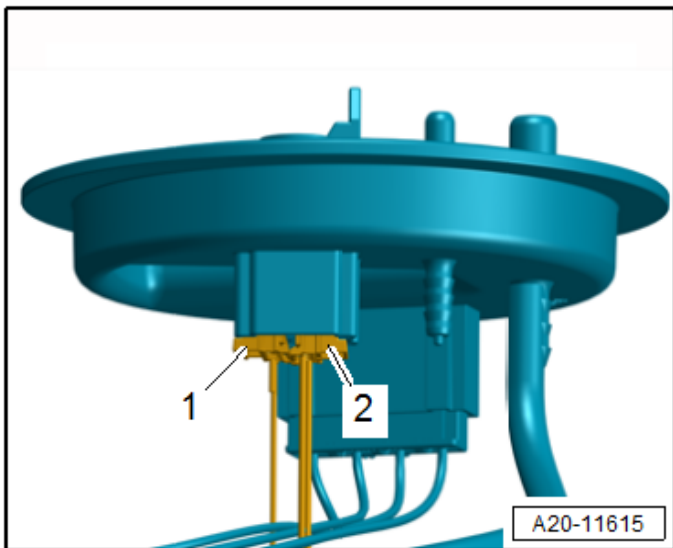

- Release and disconnect the connectors on the sealing flange.
 1. For the Fuel Level Sensor -G-
 2. For the Fuel Level Sensor 2 -G169-

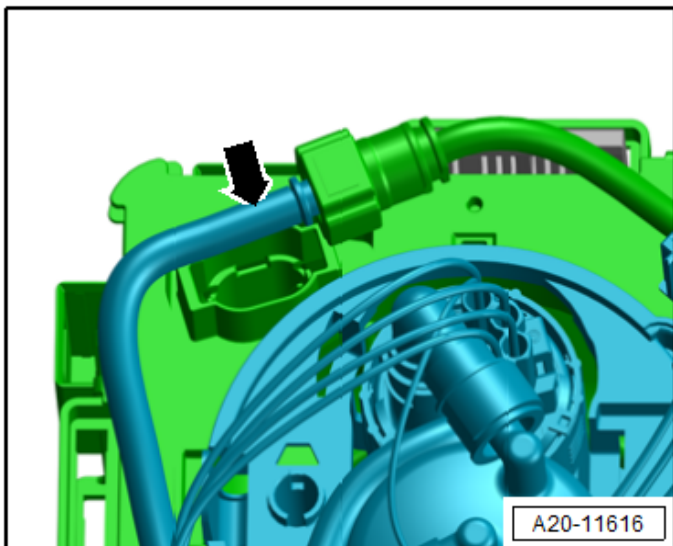

Disconnect suction jet line (version 1):

- Reach through the opening in the fuel tank and disconnect the suction jet line <arrow>.

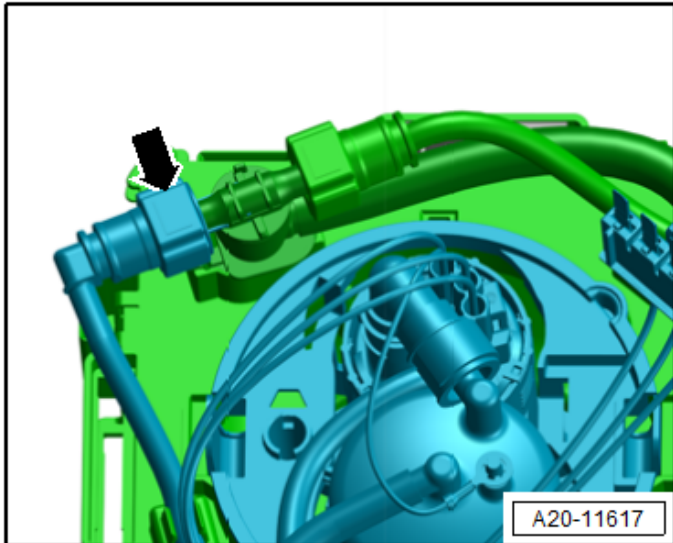

Disconnect suction jet line (version 2):

- Reach through the opening in the fuel tank and disconnect the suction jet line <arrow>.

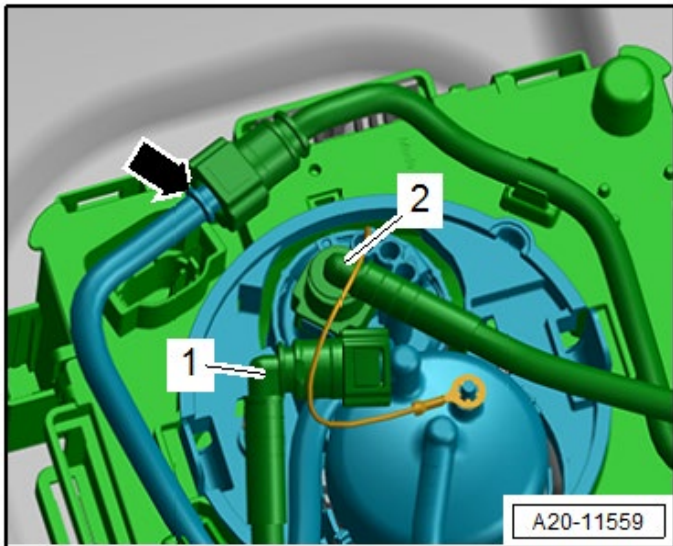

Vehicles with high-voltage system:

- Reach through the opening in the fuel tank and disconnect the suction jet line <arrow>.
- Disconnect the fuel lines <1 and 2>.

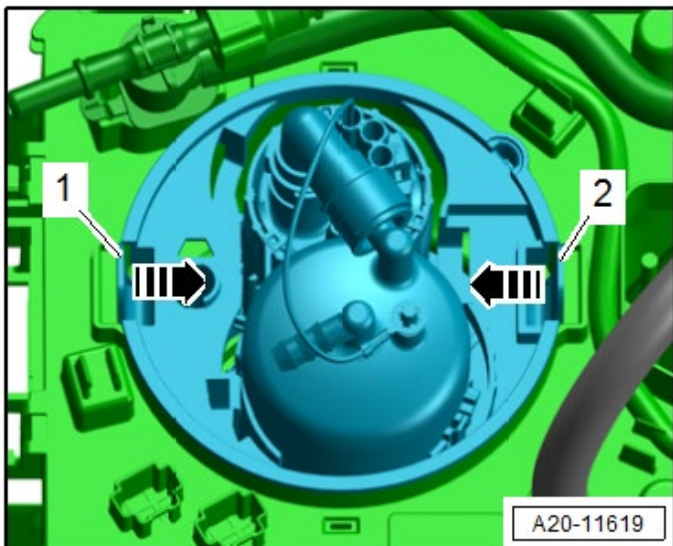

Remove fuel delivery unit:

⚠ CAUTION

Risk of a fire due to leaking fuel.

Leaking fuel may ignite and start a fire.

Lay cloths below to catch the leaking fuel.

- Reach through the opening in the fuel tank, press the catches <1 and 2> one after the other in the direction of the <arrow> and at the same time release the fuel delivery unit.
- Carefully remove the fuel delivery unit from the fuel tank opening and free up the wiring harness.

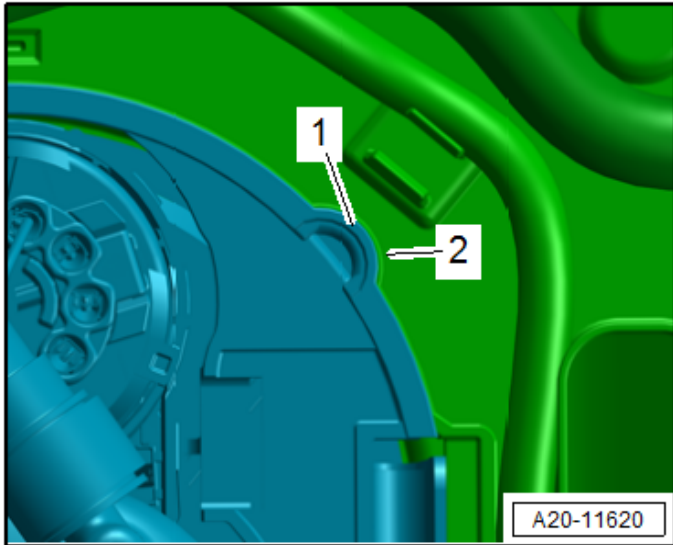

Install new fuel delivery unit:

Part Number	Part Description
4M0-919-087-F	Fuel delivery unit

- Installation is the reverse order of removal.
- Carefully guide the fuel delivery unit into the fuel tank.
- Reach through the opening in the fuel tank and move the fuel delivery unit into its installation position.
- The tab <1> on the fuel delivery unit must be in the groove on the baffle housing <2>.

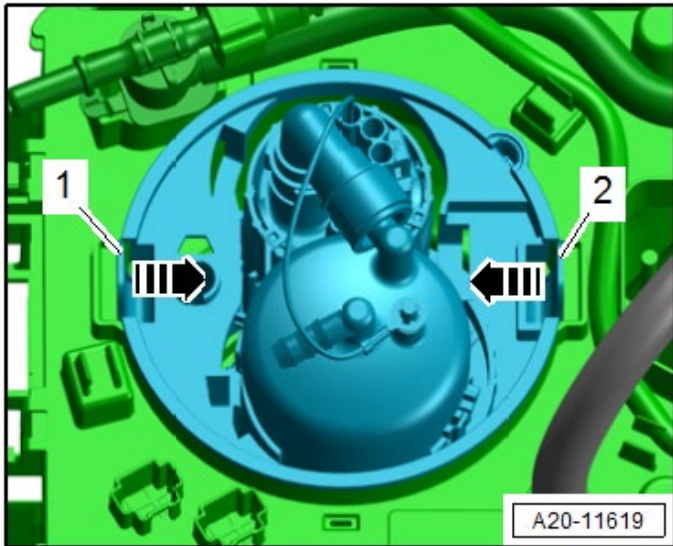

- Push the fuel delivery unit downward until it engages audibly into the catches on the baffle housing.
- Push on the fuel delivery unit again and pull on it to check if the catches <1 and 2> are engaged correctly.
- Reach through the opening in the fuel tank and attach the suction jet line to the fuel delivery unit until it clicks into place.

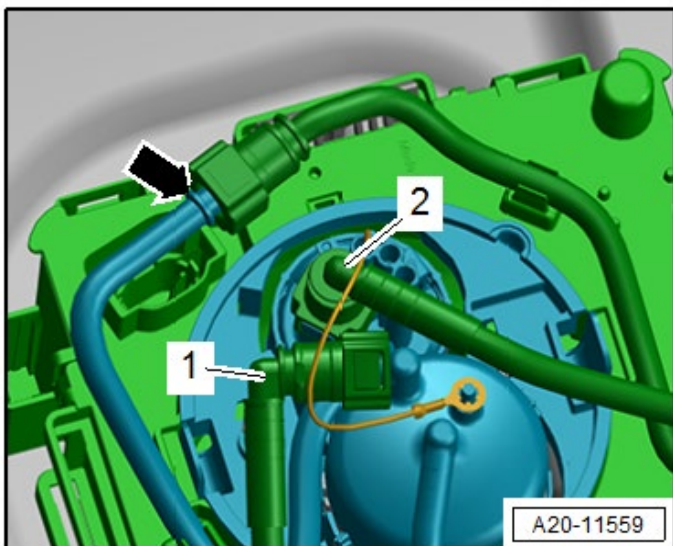

- Reconnect fuel lines and suction jet lines.
- Ensure the couplings audibly engage when reconnecting.

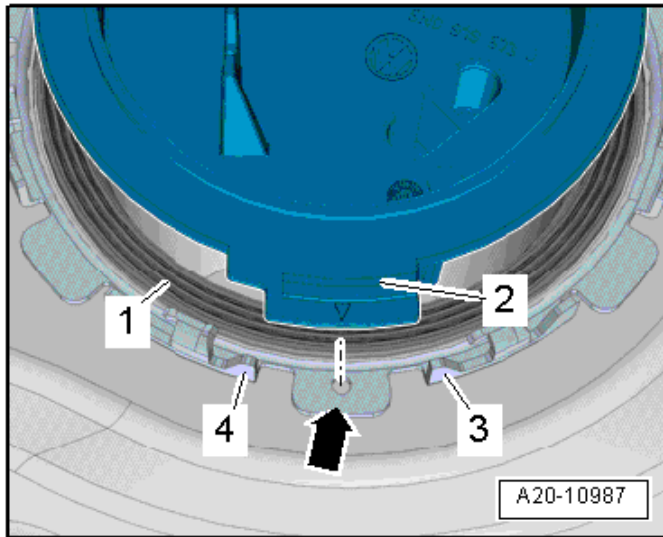

- Connect connectors to sealing flange.
- Install a new sealing flange seal <1>.
 - The seal must be installed dry.

Part Number	Part Description
1J0-919-133-B	Seal

- When inserting the sealing flange, the seal must not be damaged or crushed.
- Bring the sealing flange into its installation position.
- The tab <2> on the sealing flange must face the hole <arrow> in the locking ring and rest between the tabs <3 and 4> on the fuel tank.

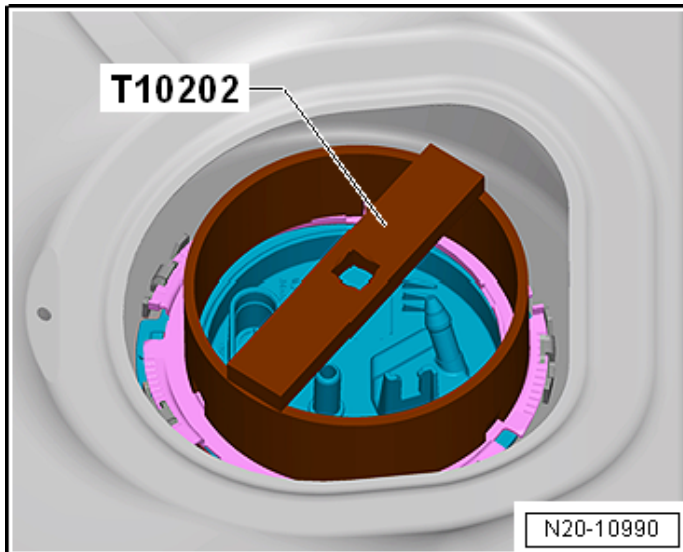

- Firmly press on the sealing flange, position the locking ring and tighten using the Wrench - Fuel Sending Unit -T10202-.
 - Torque sealing ring to 110 Nm.
- It must be ensured that at least five liters of fuel are in the fuel tank after installing the fuel delivery unit.

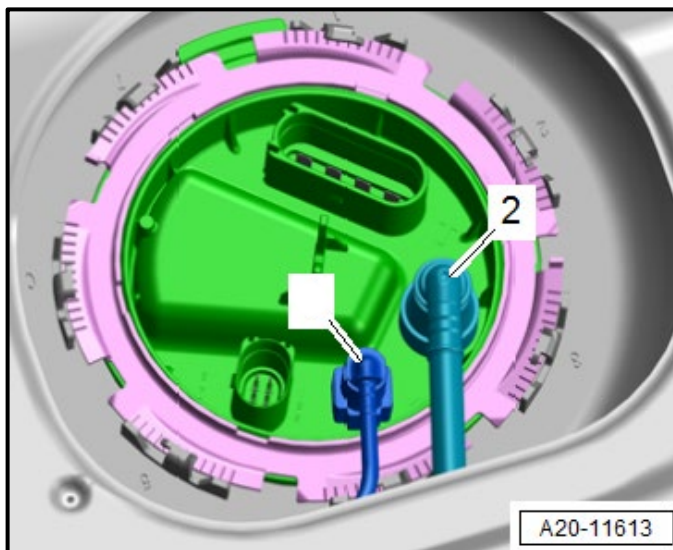

Reconnect electrical connector and fuel line:

- Reconnect electrical connector and fuel line.
- Attach the fuel line until they engage audibly.

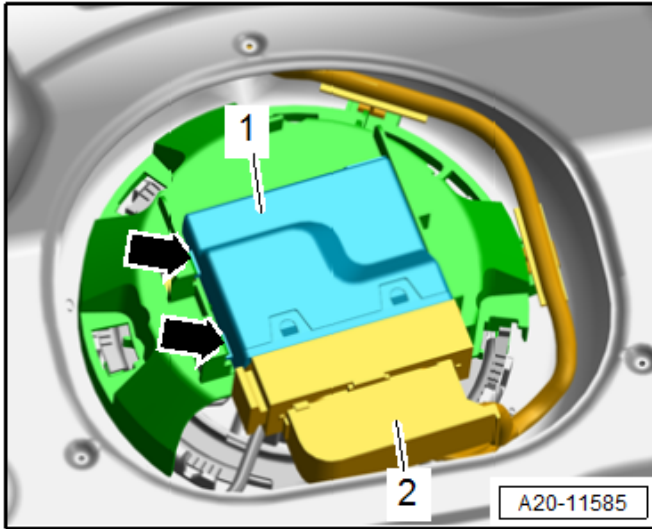

Reinstall fuel pump control module bracket and fuel pump control module:

- Installation is the reverse order of removal.

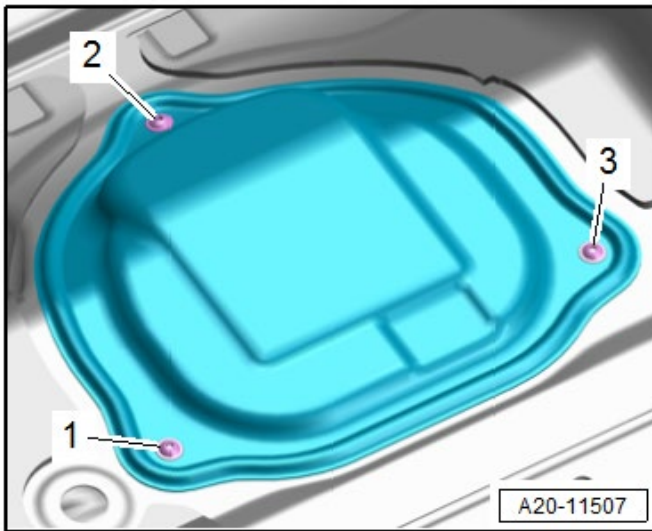

Reinstall fuel delivery unit cover:

- Installation is the reverse order of removal.
- Torque screws to 1.5 Nm.

Section D – Q8 Disassembly/Reassembly Steps

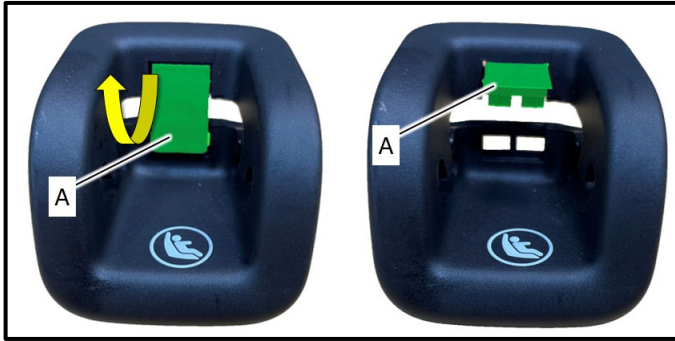

Remove child seat anchors:

- When removing the child seat anchor covers, flap <A> will have to be unlocked as shown.

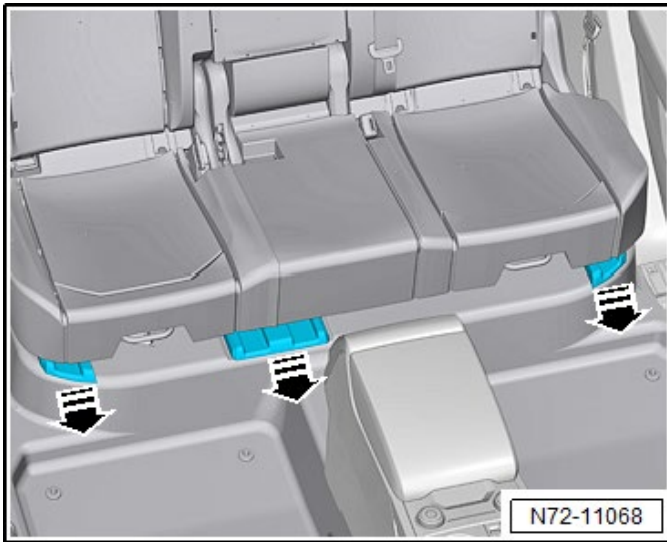

Remove seat frame bolt covers:

- Loosen the seat bolt caps and remove forward in the direction of the <arrow>.



NOTE

When removing the seat rail covers, slightly lift the front of the cover with a screwdriver first, then slide the cover forward.

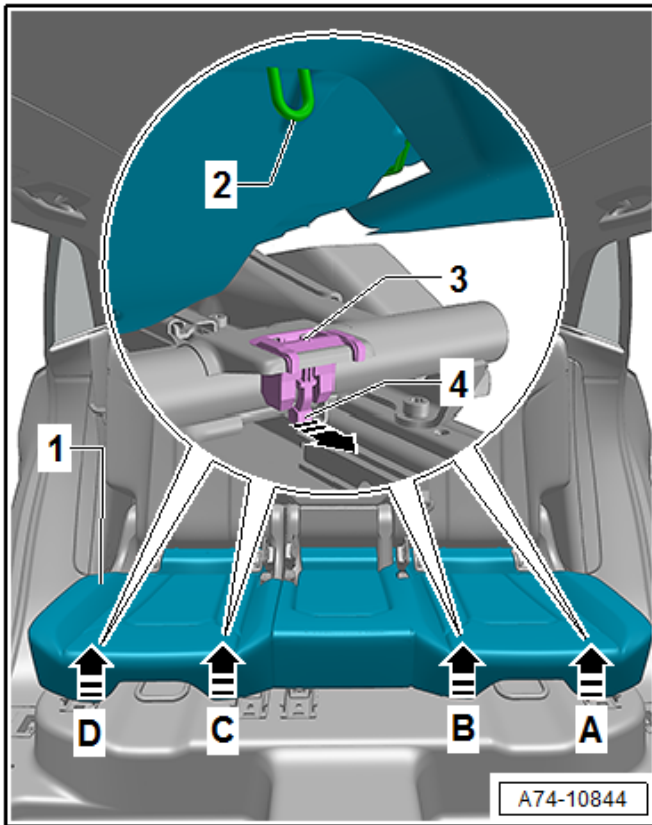

Remove left and right rear seat cushions:

NOTE

Removal and installation is described for the 2/3 unit rear bench seat. Removal and installation for the 1/3 unit and the 3/3 unit is done the same.

- Pull the release <4> on the mounting grommets <3> toward the front in the direction of <arrow> and pull the rear bench seat cushion upward.

NOTE

Replace any grommets <3> that are damaged.

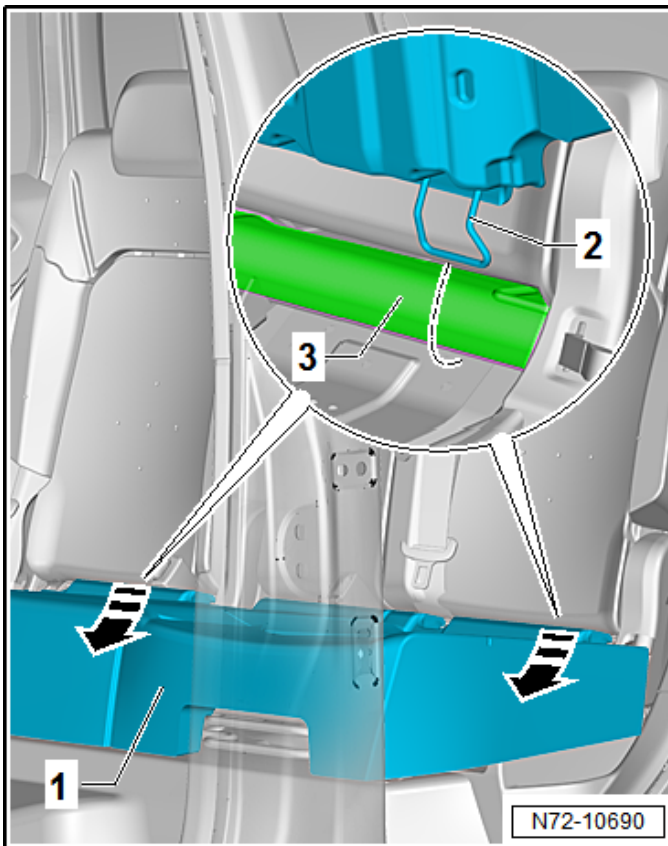

- Lift the front of the rear bench seat cushion <1> slightly and remove the wire frame <2> forward from the frame <3> in the direction of <arrows>.
- Depending on vehicle equipment, release and disconnect any connectors.
- Remove the rear bench seat from the vehicle.

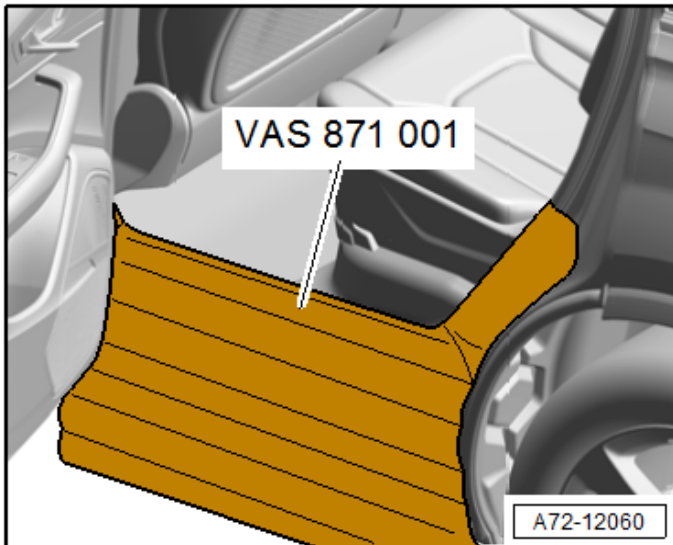

Remove rear seat bench frames:

- To protect the sill panel before removing the rear seat, apply the Universal Vehicle Protector -VAS871001-.

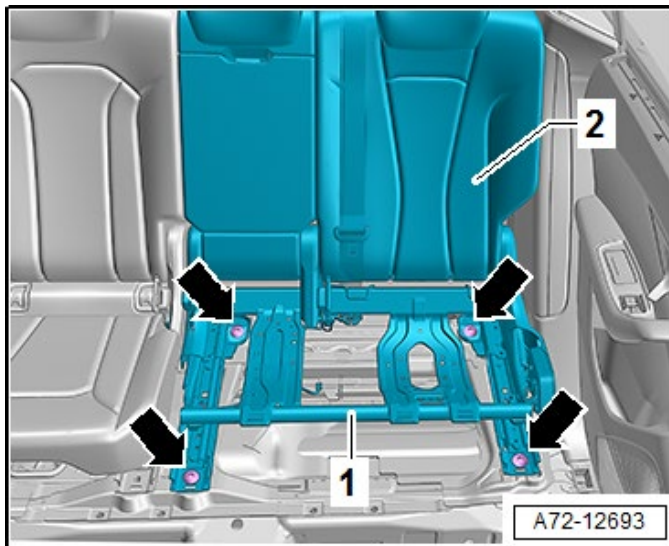

- If possible, position the rear seat as far back as possible using the forward/back adjustment.
- Remove the bolts <arrows>.
- Fold the backrest on the rear seat <2> forward.
- Remove the rear seat <1> carefully from the vehicle with a second technician.

NOTE

The following steps describe removing the luggage compartment trim on the left side.

The trim requires removal on both sides of the luggage compartment.

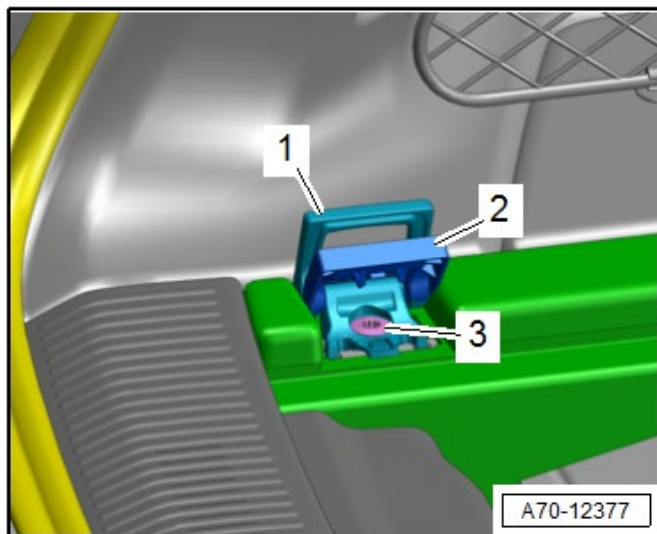

Remove tie downs:

- Fold up the bracket <1> all the way.
- Unclip the cover <2> using a screwdriver and unfold all the way.
- Remove the bolt <3> and remove the tie down.

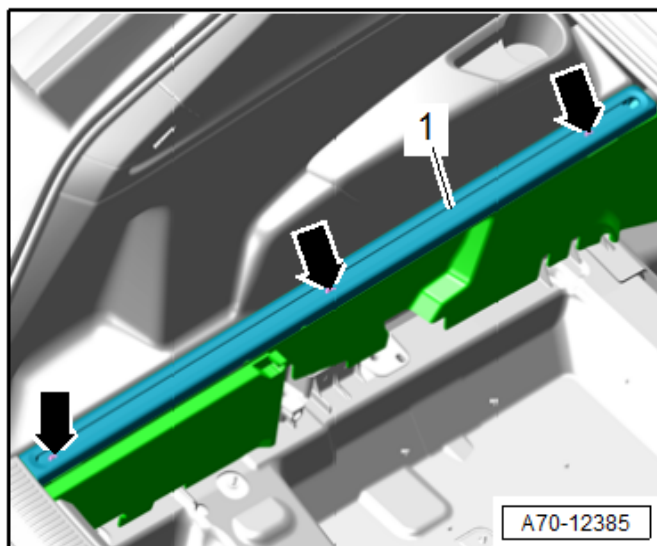

Remove rail (if equipped):

- Remove the luggage fastening strap or the telescopic luggage bar.
- Remove the bolts <arrows> and remove the rail <1>.

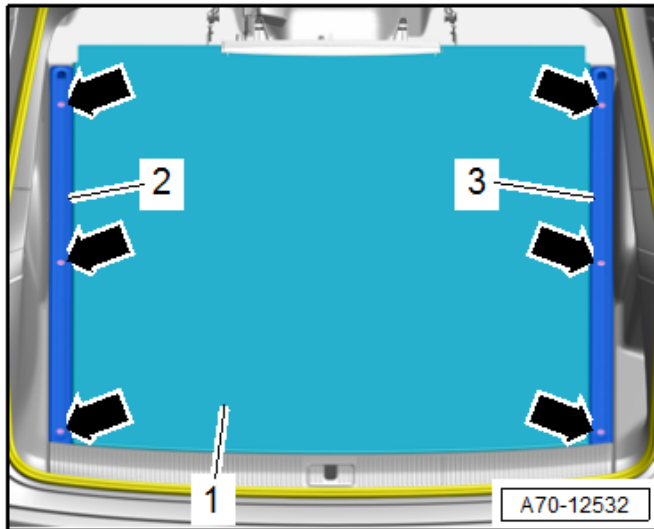

Remove luggage compartment floor:

NOTE

Floor for vehicles with 48V system shown. Removal is similar for vehicles without a 48V system. Refer to the ELSA Repair Manual as needed.

- Remove the bolts <arrows>.
- Remove the rails <2 and 3>.
- Remove the luggage compartment floor <1> upward.

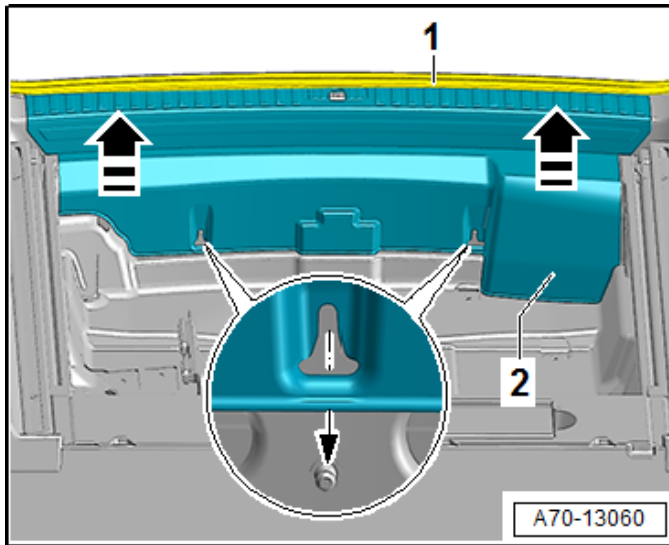

Remove lock carrier trim panel:

- Free up the lock carrier trim panel <2> near the rear lid seal <1>.
- Grip the trim panel <2> by hand and carefully pull vertically upward using a jerking motion in the direction of the <arrow>.

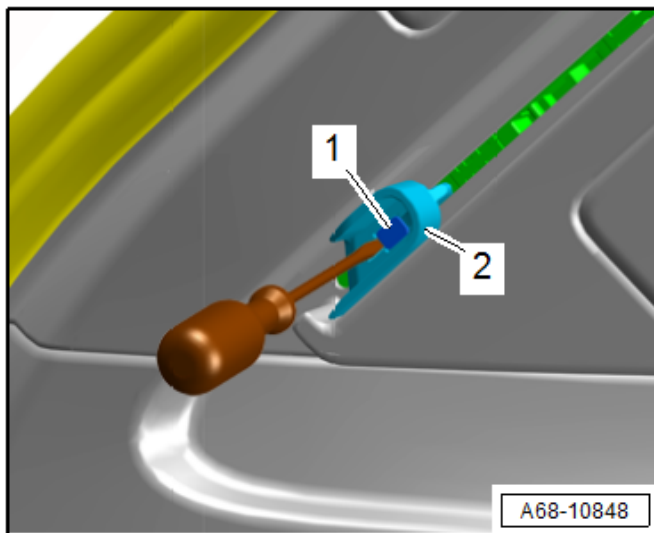

Remove luggage compartment side trim:

- Remove the luggage compartment roll cover.
- If equipped, pry out the expanding pin <1> with a small screwdriver up to the second stop.
- If equipped, remove the roll cover driver <2>.

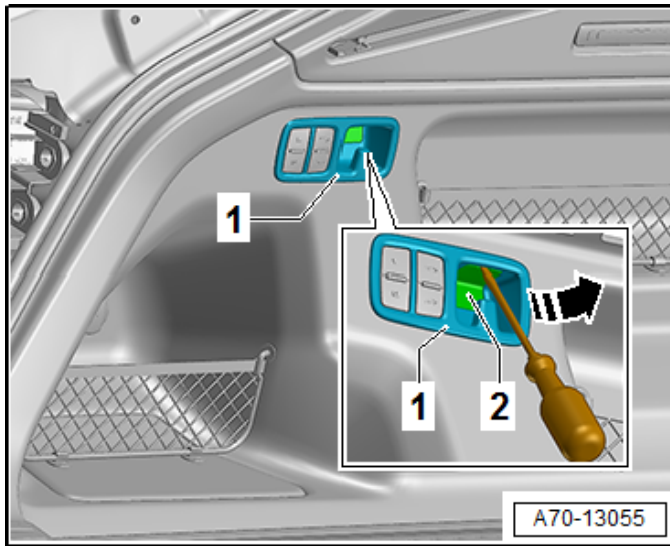

Vehicles with Loading Sill Lowering and Trailer Hitch Control Head -EX52-:

- Pry out the trim <2> with a small screwdriver in the <direction of the arrow>.

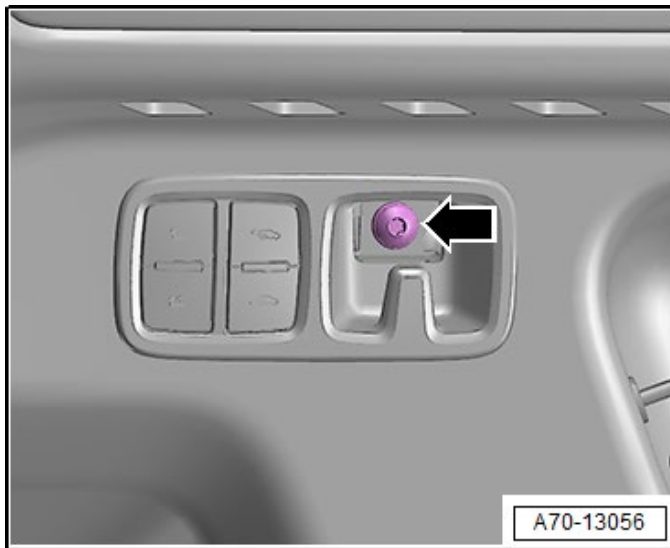

- Remove the bolt <arrow>.

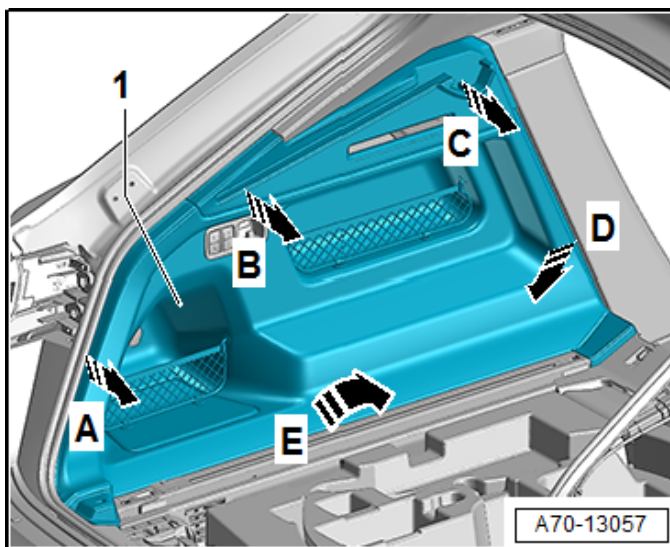

Remove luggage compartment side trim panel (continuation for all vehicles):

- Free up the luggage compartment side trim panel in the area of the rear lid seal.
- Unclip the luggage compartment side trim panel <1> from the body starting at the back in the direction of the <arrow A to D>.
- Pull the luggage compartment side trim panel slightly inward while releasing and disconnecting the connectors.
- Loosen the emergency release adjusting element for the fuel filler door and guide out on the right side luggage compartment trim panel.
- Pull the luggage compartment side trim panel upward from the support direction of <arrow E> and remove it.

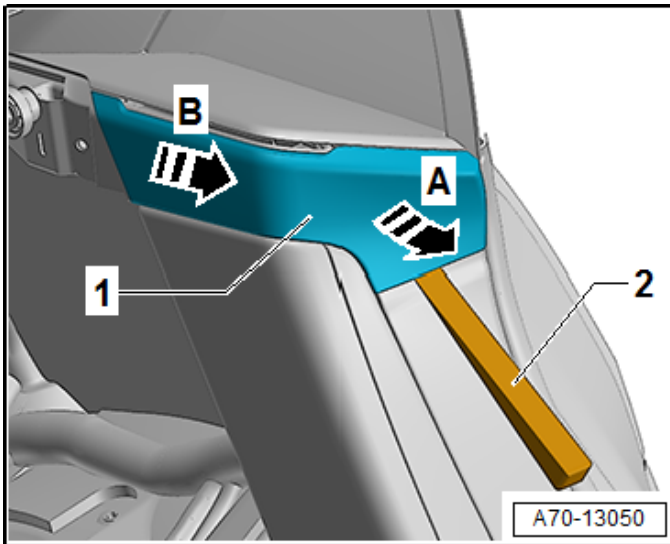

Remove lower D-pillar trim:

- Pry out the trim <1> with the scraper <2> in the direction of the <arrow A>.
- Remove the trim <1> in the direction of the <arrow B>.

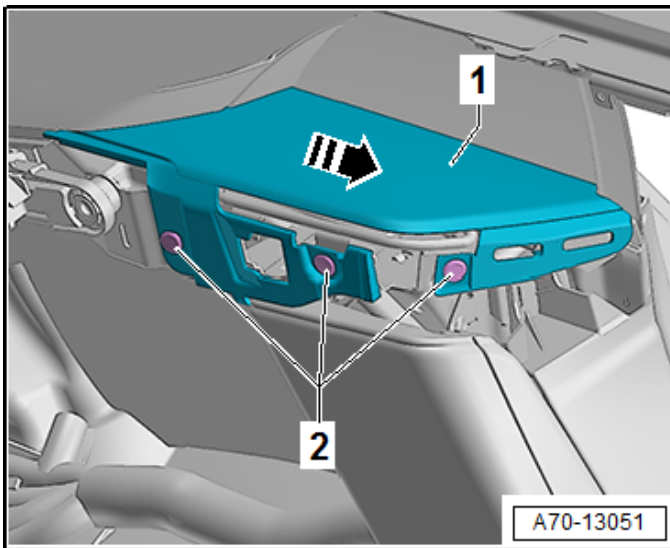

- Remove the expanding rivets <2> with scraper no. 4.
- Unclip the cover <1> and remove in the direction of the <arrow>.

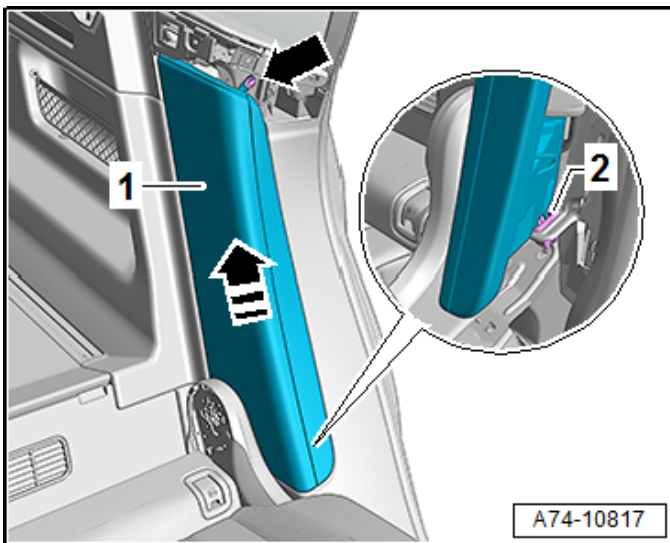

Remove side cushion:

- Remove the bolt <arrow>.
- Unclip the side cushion <1> from the wheel housing trim panel and remove upward in the direction of the <arrow> from the clip <2>.

CAUTION

Pyrotechnical components can deploy unintentionally.

Risk of injury.

Discharge the static electricity: quickly touch the door striker.

- Versions with rear thorax airbag: unlock and disconnect the connector.

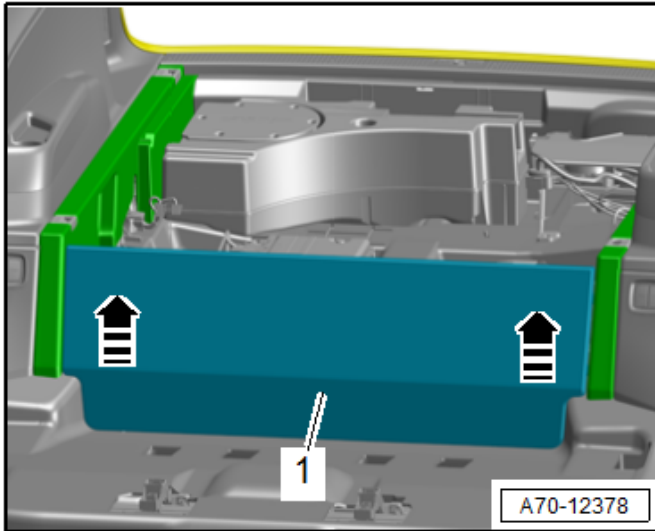

Remove bulkhead partition cover:

- Fold the second row seats forward.
- Disengage the bulkhead partition cover <1> on the side <arrows> and remove.

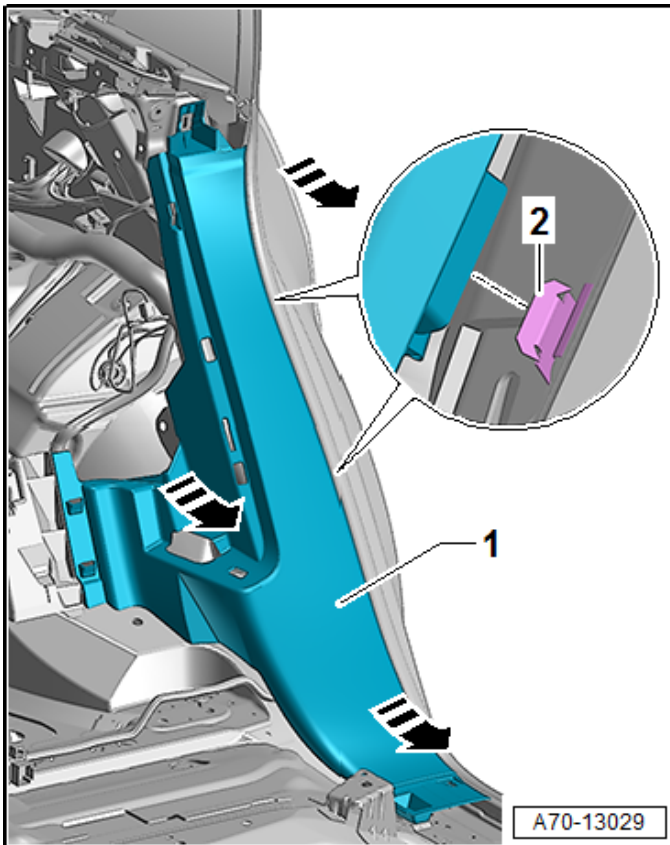

Remove rear sill cover trim:

- Unclip the front sill panel in the rear section of the rear sill panel <1>.
- Free up the sill panel in the door seal area.
- Unclip the sill panel <1> from the clamps <2> starting at the bottom using the -3409-.
- Disengage the sill panel <1> on the luggage compartment bracket and remove in the direction of the <arrow>.

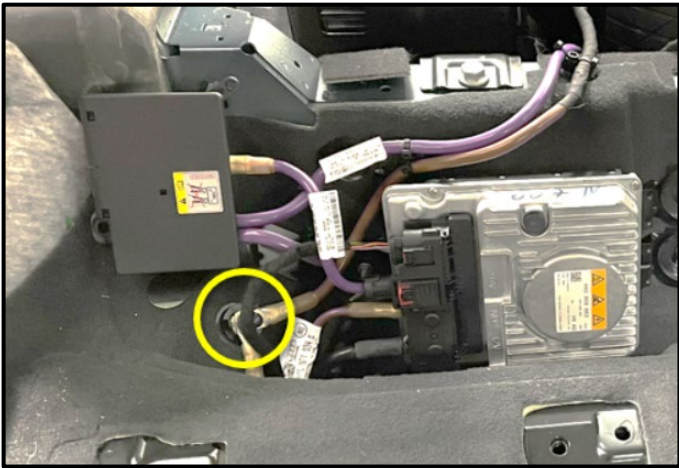

Disconnect ground connection (if equipped with 48V system):

- Remove nut <circle> and remove ground cable connections.

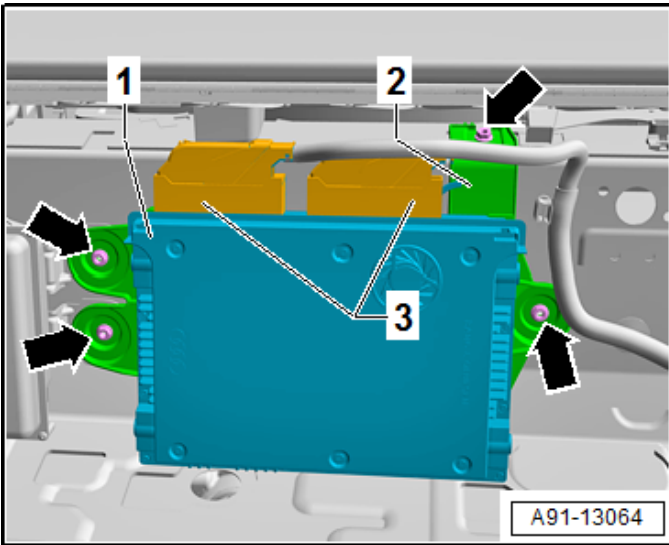

Loosen Digital Sound System Control Module - J525- bracket (if equipped):

- Remove the bolts <arrows> from the bracket <2> and set aside the Digital Sound System Control Module -J525- with the connectors connected.

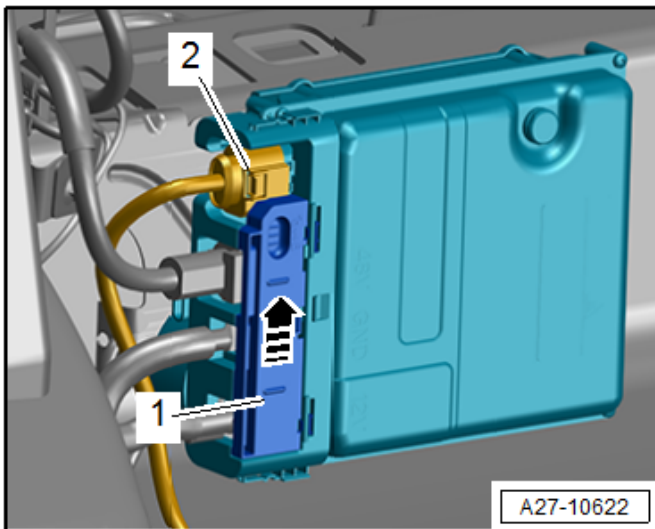

Disconnect wires from voltage converter (if equipped with 48V system):

- Disconnect the connector <2>.
- Slide the cover <1> upward in direction of <arrow> to release it and then open it.

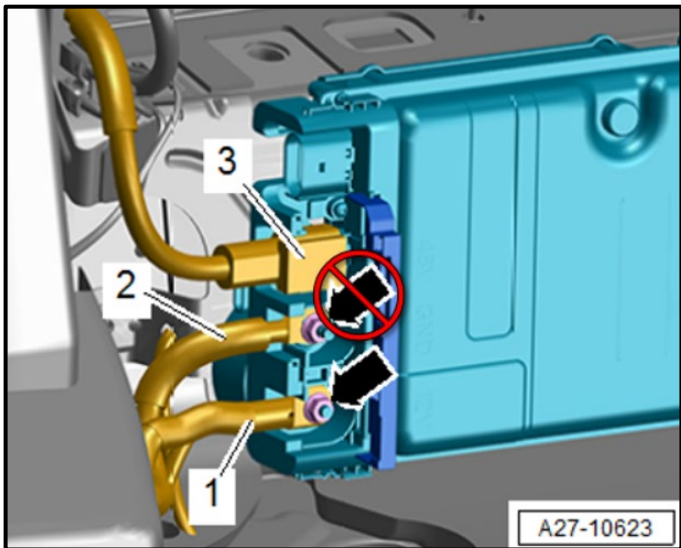

- Disconnect the connector <3>.
- Remove the nut <arrow>.
- Free up the wire <1>.

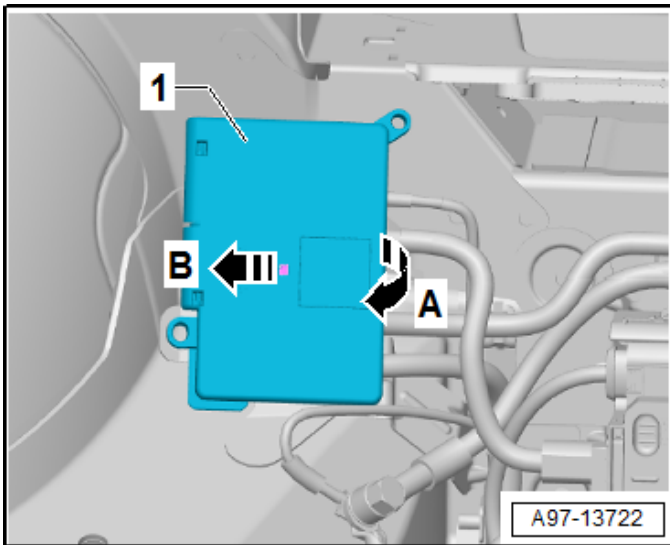

Disconnect power wire from Terminal 40 Wire Junction 2 -TV67- (if equipped with 48V system):

- Release the retainer in direction of <arrow B> and open the cover <1> in direction of <arrow A>.

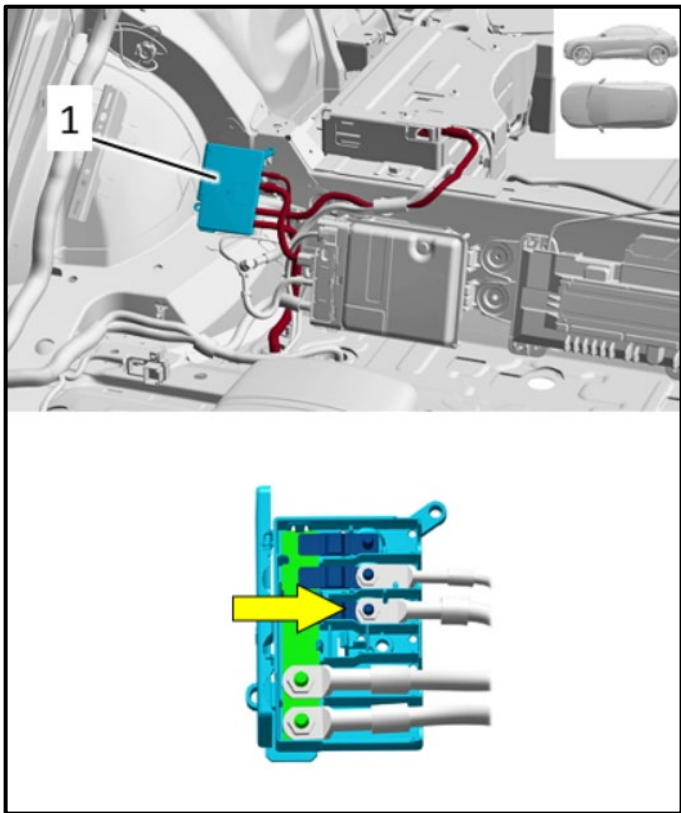

- Loosen the nut and free up wire <arrow> from the Terminal 40 Wire Junction 2 -TV67- <1>.
- Immediately cover the cable end with Cable Cover -VAS6762/10- (or equivalent).
- Close the cover on the junction box.

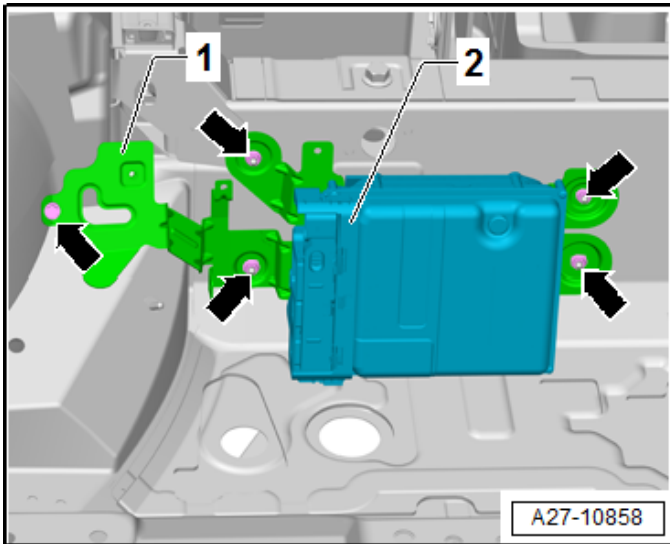

Remove bracket (if equipped with 48V system):

- Remove bolts <arrows>.
- Remove bracket <1> and set aside with Terminal 40 Wire Junction 2 -TV67- and voltage converter still attached.

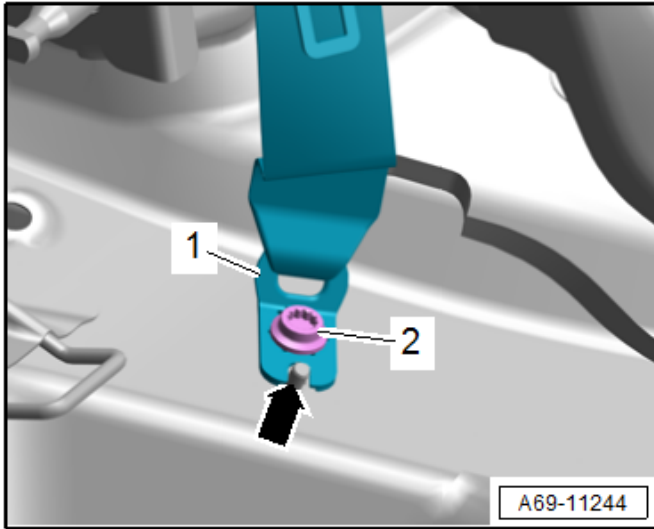

Remove rear outer seat belt end fitting:

- Remove the bolt <2> from the belt end fitting <1>.



Position carpet:

- Fold carpet forward and secure out of the way to gain access to rear seat frame mount.

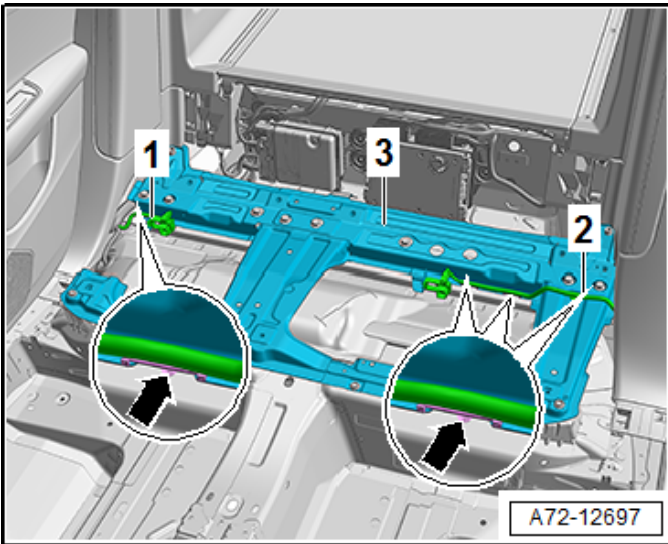

Remove rear seat frame mount:

- Unclip the wire <1 and 2> on the seat frame mount <3> <arrows>.

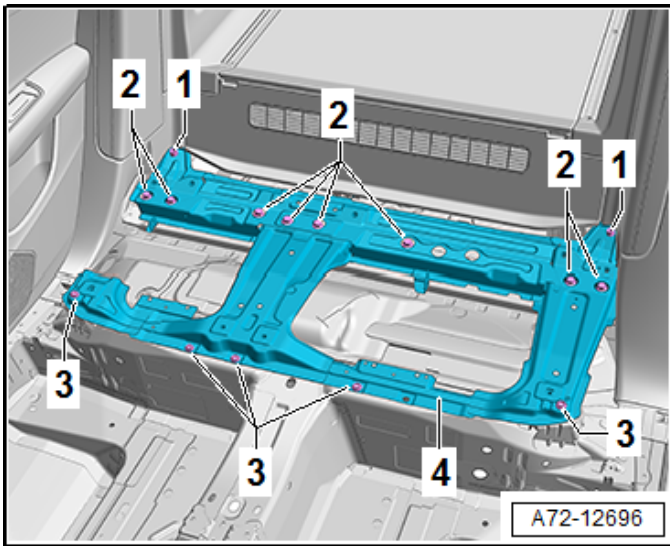

- Remove the bolts <1, 2, and 3>.
- Remove the seat frame mount <4> with a second technician.

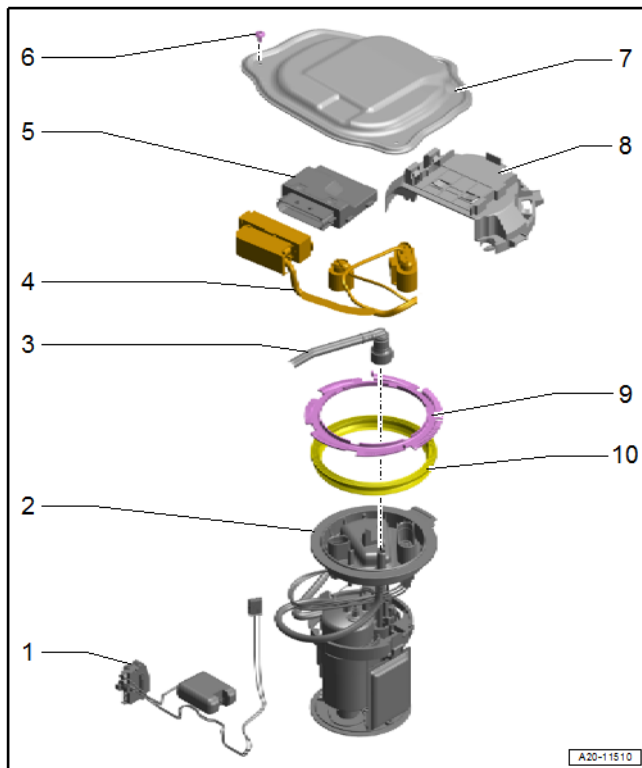

Replace fuel delivery unit:

- See Section C

Reassemble vehicle:

Reassembly is the reverse order of removal. Note the following:

- Torque seat frame mount bolts to 50 Nm (pay attention to the different bolt sizes).
- Torque seat belt end fitting bolt to 40 Nm.
- Torque bolts for Terminal 40 Wire Junction 2 -TV67- bracket to 3.5 Nm.
- Torque cable fastener <arrow> to 9 Nm.

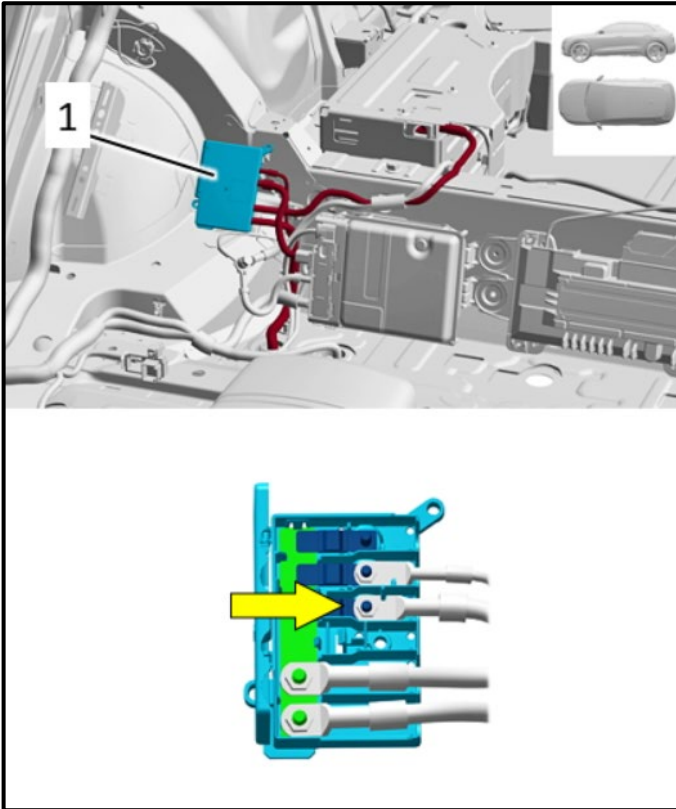

- Torque ground connection <circle> to 3.5 Nm + 45°.
- **DO NOT over torque.**

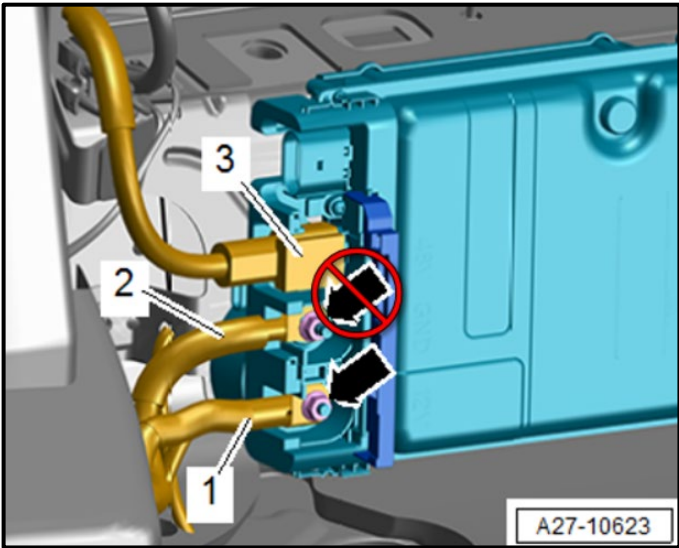

- Torque nut for cable <1> to 20 Nm.

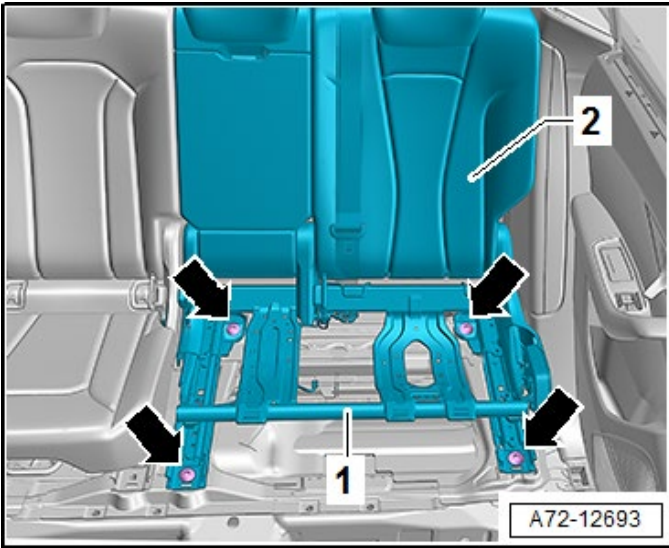

- Torque seat frame bolts <arrows> to 50 Nm.
- If the rear seat cushion grommets are damaged, they should be replaced.

After repairs are complete, Proceed to Section F

Section E – Q7 Disassembly/Reassembly Steps

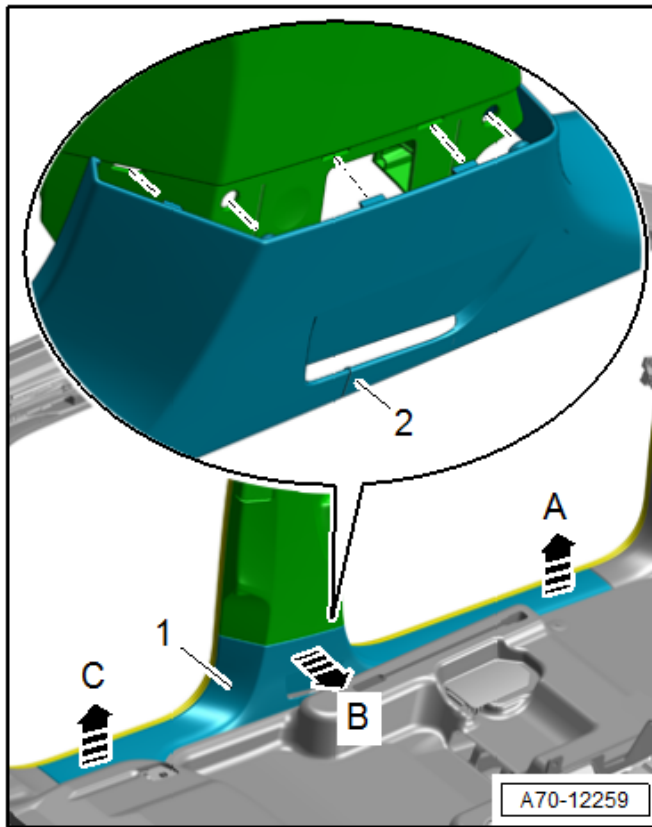

Remove right front and right rear sill panels:

- Move the front seat all the way forward and up.
- Free up the sill panel in the area of the door seal.
- Unclip the sill panel <1> from the side sill starting at the front using the -3409- <arrow A>.
- Release the retaining tab from the sill panel strip from B-pillar trim using the -T10383/1- <arrow B>.
- Unclip the sill panel from the back of the side sill using the -3409- <arrow C>.
- Open the tab <2> on the sill panel strip, guide out the strap and remove the sill panel strip.

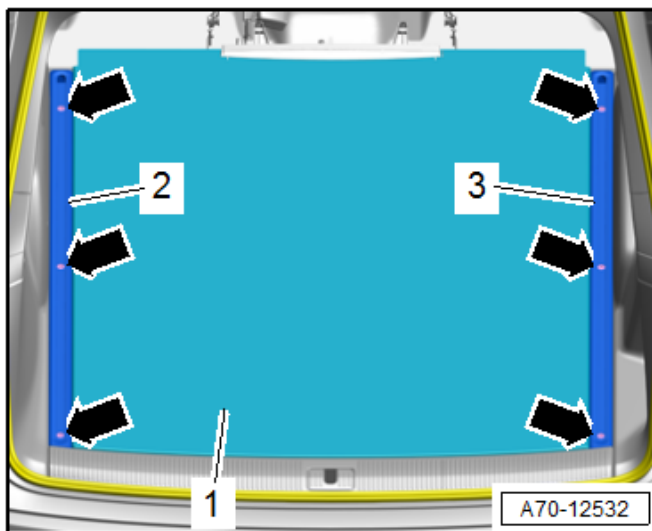

Remove luggage compartment floor:

NOTE

Floor for vehicles with 48V system shown. Removal is similar for vehicles without a 48V system. Refer to the ELSA Repair Manual as needed.

- Remove the bolts <arrows>.
- Remove the rails <2 and 3>.
- Remove the luggage compartment floor <1> upward.

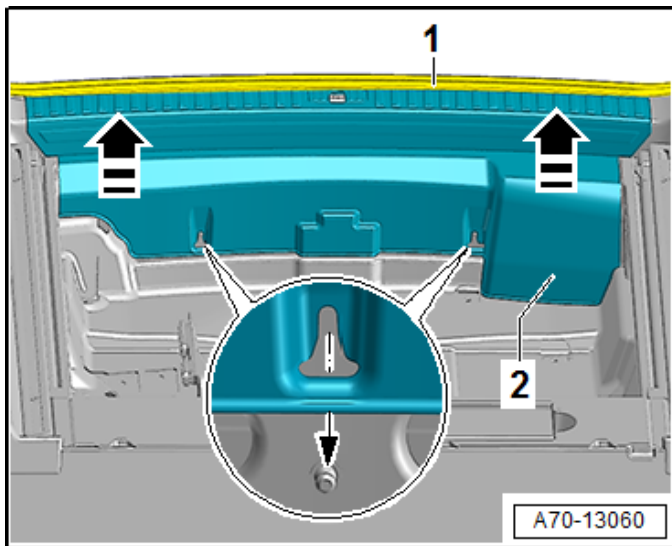

Remove lock carrier trim panel:

- Free up the lock carrier trim panel <2> near the rear lid seal <1>.
- Grip the trim panel <2> by hand and carefully pull vertically upward using a jerking motion in the direction of the <arrow>.

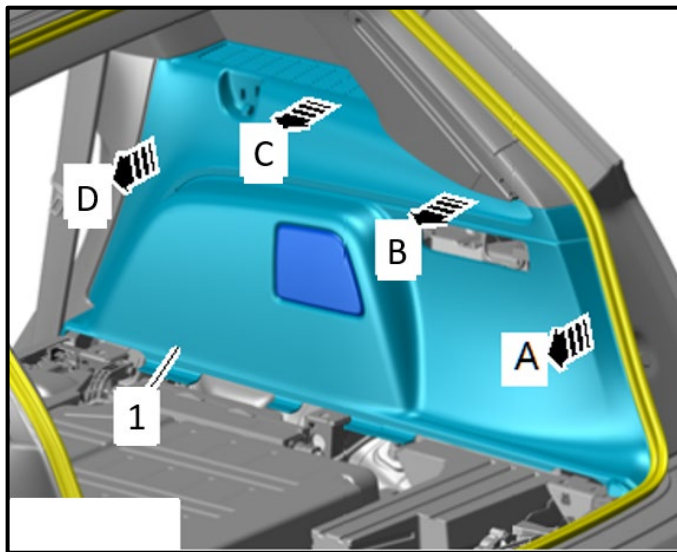

Remove passenger luggage compartment side panel:

- Remove luggage compartment lamp.
- Free up the luggage compartment side trim panel near the rear lid seal.
- Unclip the luggage compartment side trim panel <1> from the body starting at the back and unclip the trim panels <arrows A to D>.
- Pull the luggage compartment side trim panel slightly inward and disconnect the connector.
- Remove the luggage compartment side trim panel toward the rear.

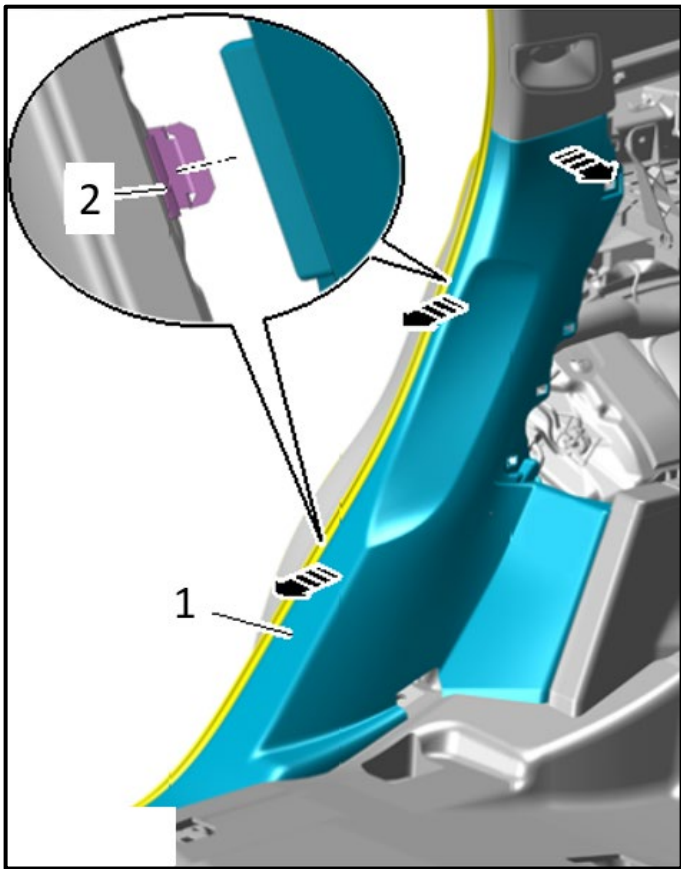

Remove rear sill panel:

- Free up the sill panel in the area of the door seal.
- Unclip the sill panel strip <1> from the clamps <2> on the sill panel starting at the bottom <arrows> using a -3409-.
- Unclip the sill panel from the C-pillar trim panel and disengage it from the luggage compartment floor support.

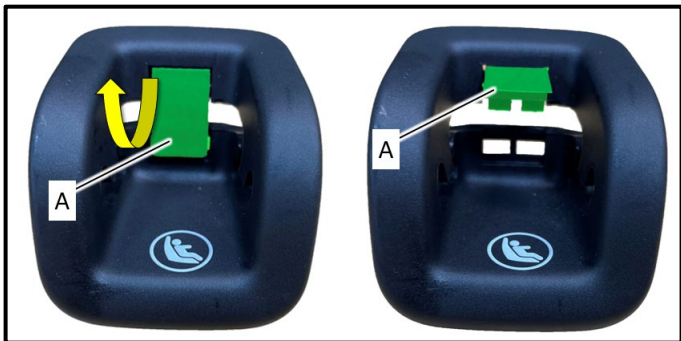

Remove child seat anchors:

- When removing the child seat anchor covers, flap <A> will have to be unlocked as shown.

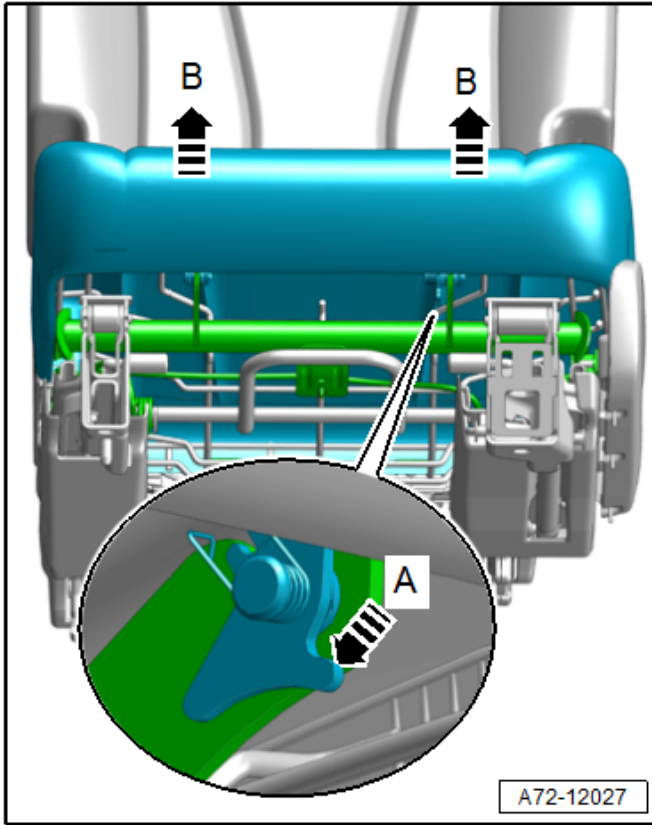

Remove seat cushion on right, second row seats:

- Press each catch on the seat frame <arrow A> and pull the cover upward <B arrows>.
- If installed, release and disconnect the connector for the seat heating.

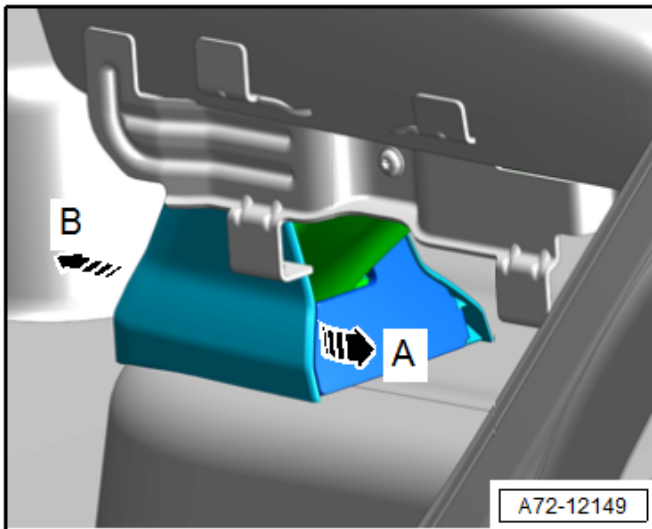

Remove seat frame rail trim:

- Release the hooks <arrow A> and remove the trim panel forward <arrow B>.

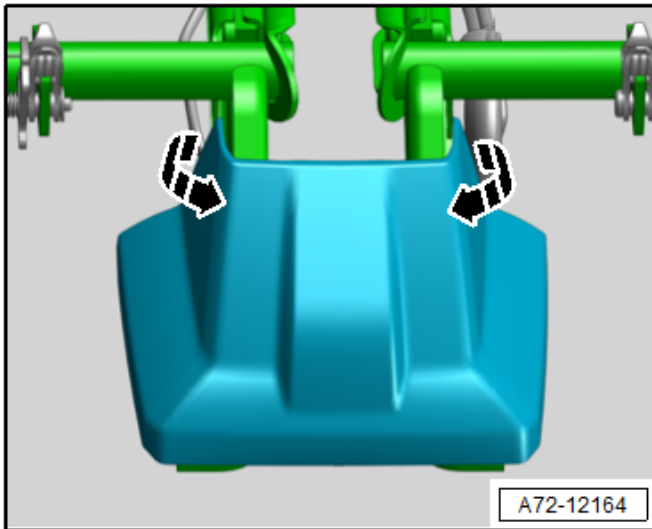

- Release the hooks <arrows> and remove the trim panel forward.

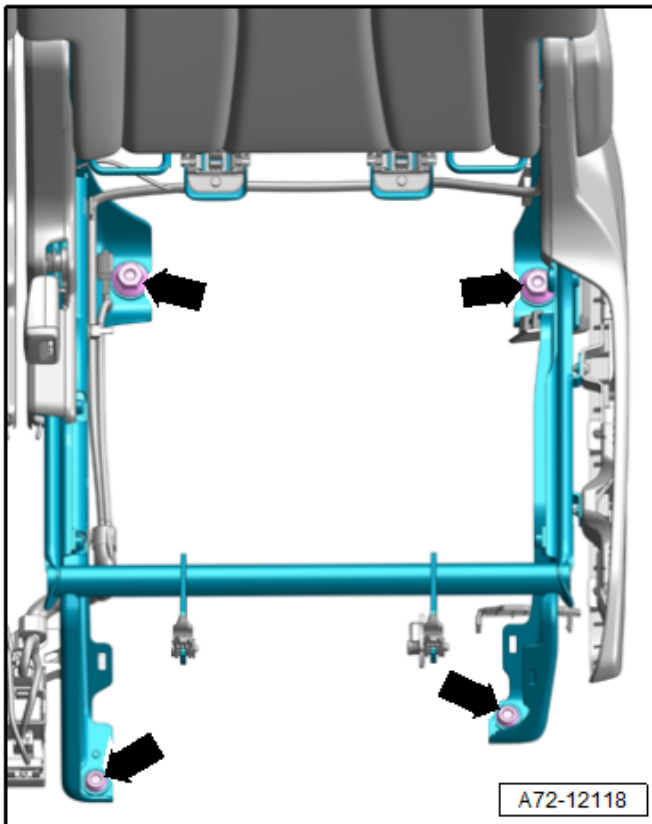

Remove right and center, second row seats:

- Disconnect connectors as needed.
- Remove the bolts <arrows>.
- To protect the sill panel before removing the rear seat, attach the -VAS871001-.
- Remove the seat from the vehicle with a second technician.

NOTE
Outer seat frame shown. Removal of center seat frame is similar.

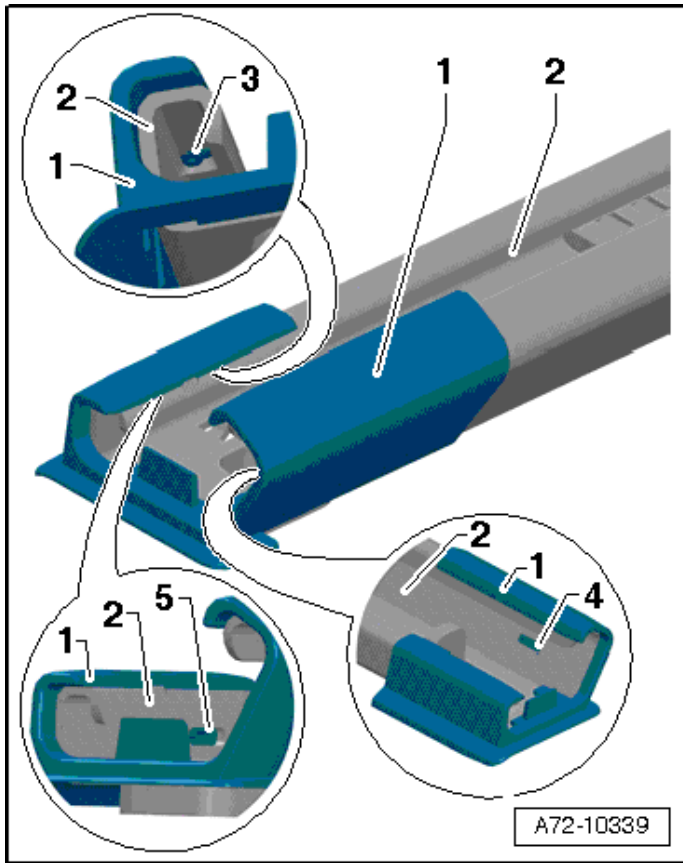

Remove rear covers from passenger front seat frame rails:

- Remove the rear cover <1> for both seat rails on the front passenger seat. To do so, carefully release the tabs <3, 4 and 5> on the seat rail <2> using a screwdriver.
- Remove the carpet under the seat rail.
- Remove the covers and connector station for the bench seat / single seats in the carpet.



Position carpet:

- Position carpet as shown to access fuel delivery unit cover.

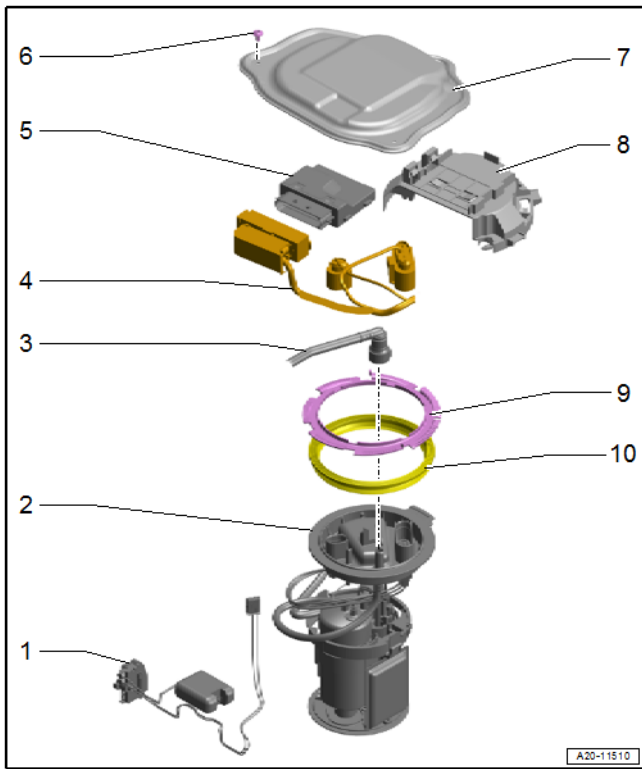

Replace fuel delivery unit:

- See Section C



Reassemble vehicle:

Reassembly is the reverse order of removal. Note the following:

- Ensure the carpet is tucked back underneath the third row seat bench and rear sill trim.

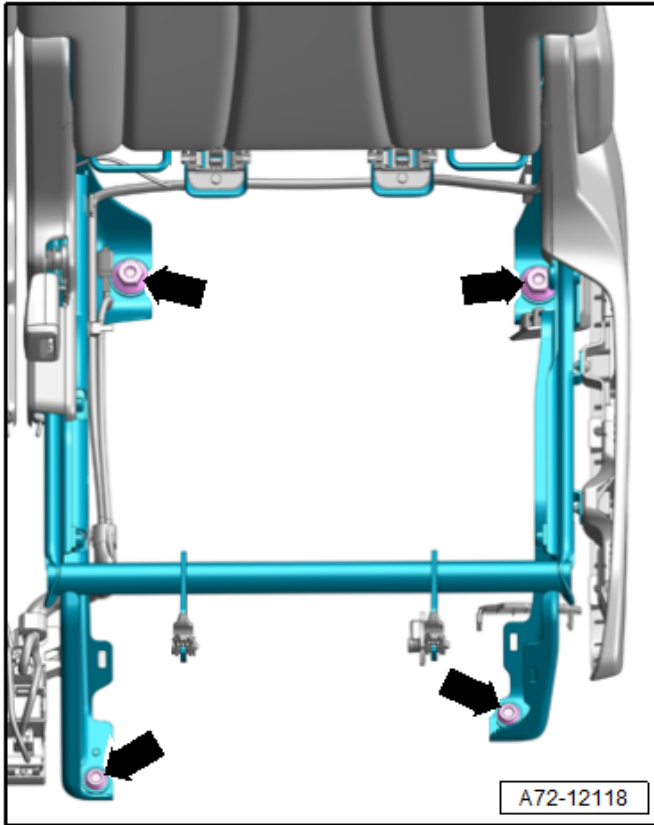

- Torque seat frame mount bolts to 50 Nm.

After repairs are complete, Proceed to Section F

Section F – Final Steps

Refill fuel:

- Ensure that at least five liters of fuel are in the fuel tank.
- As a best practice the fuel tank should be filled with the same amount of fuel that was removed.

⚠ WARNING

Risk of the fuel tank exploding when starting the fuel pump.

Severe injuries and burns are possible.

After installing a new or completely empty fuel tank, immediately fill with at least 5 liters of fuel.

Reconnect 12V battery:

- See ELSA Repair Manual: *Repair manual > Electrical System > Electrical Equipment > 27 Battery, Starter, Generator, Cruise Control > Battery, Disconnecting and Connecting*

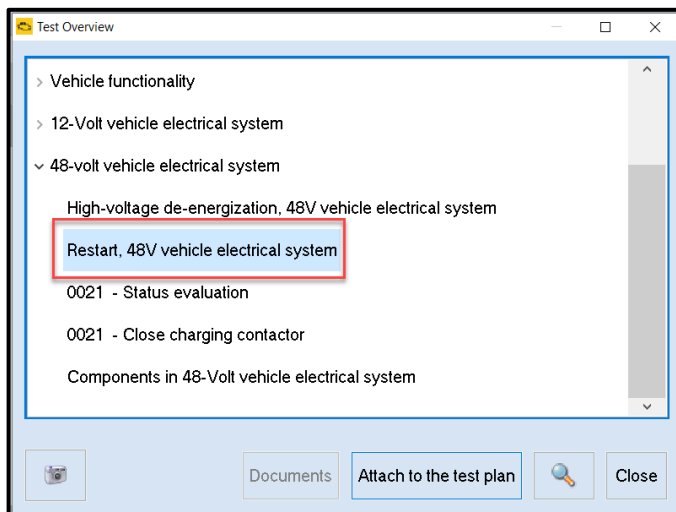
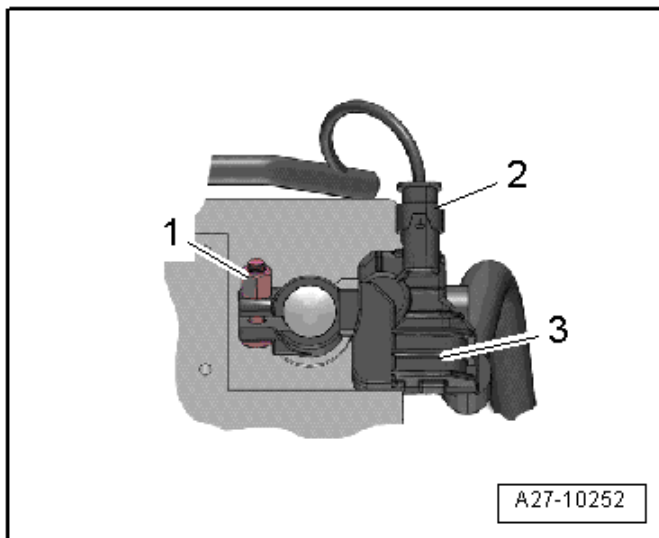

Restart 48V HV system (if equipped):

- Select test plan, “Restart, 48V vehicle electrical system.”
- Follow the ODIS test plan steps.
- Send Diagnostic log to GFF Paperless upon exiting ODIS.

Final steps:

- Cycle ignition on and off a few times.
- Start vehicle and confirm fuel level is reading correctly.

Proceed to Section G

Section G – Campaign Completion Stamp

I certify that this campaign has been performed in strict accordance with the applicable Audi repair procedure.

SAGA Code: _____

Technician: _____

Date: _____

Item#: AUD4927ENG

-OR-

Je certifie que cette campagne de rappel a été exécutée suivant les strictes directives de réparation d'Audi

Code de SAGA: _____

Technicien: _____

Date: _____

Item # AUD4927FRE

- Once the campaign has been completed, the technician should stamp the repair order.
- Stamps are available for ordering through the Compliance Label Ordering Portal.
- **Proceed to Section H**

Section H - Parts Return/Disposal

Properly store (retain), destroy or dispose of removed parts in accordance with all state/province and local requirements, unless otherwise indicated and/or requested through the Warranty Parts Portal (WPP) for U.S. and the Part Destruction and Core Disposition Report for Canada.