



PREVOST

**SAFETY
RECALL**

SR22-310

DATE :	August 2022	SECTION :	18 CHASSIS
SUBJECT:	USSC REAR BENCH SEAT BOLT MISSING		

First Release

08-30-2022

APPLICATION

NOTICE TO SERVICE CENTERS

*Verify vehicle eligibility by checking warranty bulletin status with **SAP** or via **ONLINE WARRANTY SYSTEM** available on Service / Warranty tab of PrevoSt website.*

Model	VIN
X3-45 Commuter. Model Year: 2021	From 4RKJ33494M9 [REDACTED] up to 4RKJ33497M9 [REDACTED] incl.

0This Safety Recall does not necessarily apply to all the above-mentioned vehicles, some vehicles may have been modified before delivery. The owners of the vehicles affected by this recall will be advised by a letter indicating the Vehicle Identification Number (VIN) of each vehicle concerned.



DESCRIPTION

On vehicles affected by this recall, one bolt that secures the rear bench seat frame to the vehicle's body was not installed during the manufacturing process because a hole required for the installation of the bolt was missing on the lower back panel.

Therefore, all affected vehicles must have this hole drilled and the required bolt installed following the procedure below.







MATERIAL

Order **KIT SR22310** which contains the following parts:

Part No.	Description	Item	Qty
5002067	SCR CAP HEX G500 7/16-20X2.25 G8 PT		1
500487	WSH LO SPT N500 .443X.779X.109(M10,7/16)		1
500897	WSH FL N500 .438X1X.083 (7/16)		1

NOTE
Material can be obtained through regular channels.

Tools required:

Tool	Description	Qty
	(SAE) Wrench & Socket Set	1
	Cordless Drill	1
	1/2 Drill Bit	1
	Drill Bit Stopper (optional)	1
	Torque Wrench (SAE)	1
	Torque Seal indicator (yellow)	As req.

SAFETY PRECAUTIONS

- Eye protection should always be worn when working in a shop.
- Rules for Personal Protection Equipment should always be respected. Wear your PPE including but not limited to the following:



Safety First!



PROCEDURE



DANGER

Park vehicle safely, apply parking brake, stop the engine. Prior to working on the vehicle, set the ignition switch to the OFF position and trip the main circuit breakers equipped with a trip button. On Commuter type vehicles, set the battery master switch (master cut-out) to the OFF position.

Lockout & Tag out (LOTO) must be performed during set-up, maintenance or repair activities. Refer to your local procedure for detailed information regarding the control of hazardous energy.

1. Remove the seat base from the 2nd curb side rear bench seat (red circle Figure1).

- Unscrew the two screws retaining the seat base to the frame (arrows Figure1).
- Lift to remove the base and expose the frame structure.

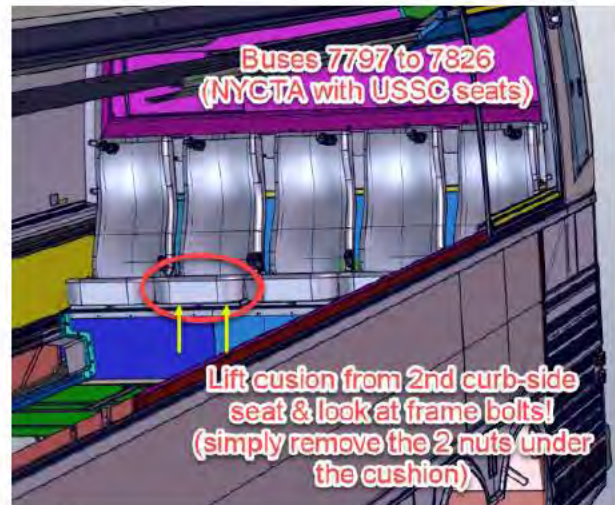

Figure1

2. Locate the slot with a missing bolt in the rear seat base structure (red circle in Figure2).

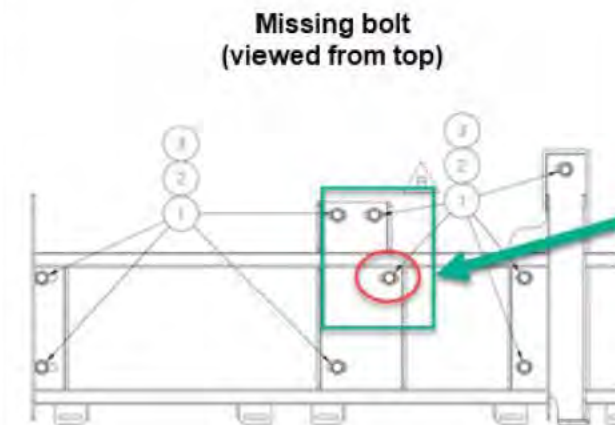

Figure2

3. Drill the missing 1/2in hole in the plywood base using the slot as a guide (Figure3).

- Using a cordless drill (or equivalent) and a 1/2 in drill bit, drill through the carpet and the plywood inside the slot to expose the welded nut behind it.

NOTE

The use of a drill stopper installed at 3/4 in from the drill tip is recommended.

IMPORTANT: Compare with the two top bolts and drill the hole at the same position (left, center or right) in the slot (right position is shown in Figure3).

- Remove wood chips and frayed carpet from the hole as necessary.



Figure3

4. Install the missing bolt and hardware (Figure4).

- Install the supplied **5002067** Bolt, the **500487** lock washer and the **500897** flat washer.
- Torque the bolt to **27 lb-ft.**
- Add a strip of yellow Torque Seal indicator to the bolt head.
- Reinstall the seat base (Torque to **27 lb-ft**) to complete the procedure.

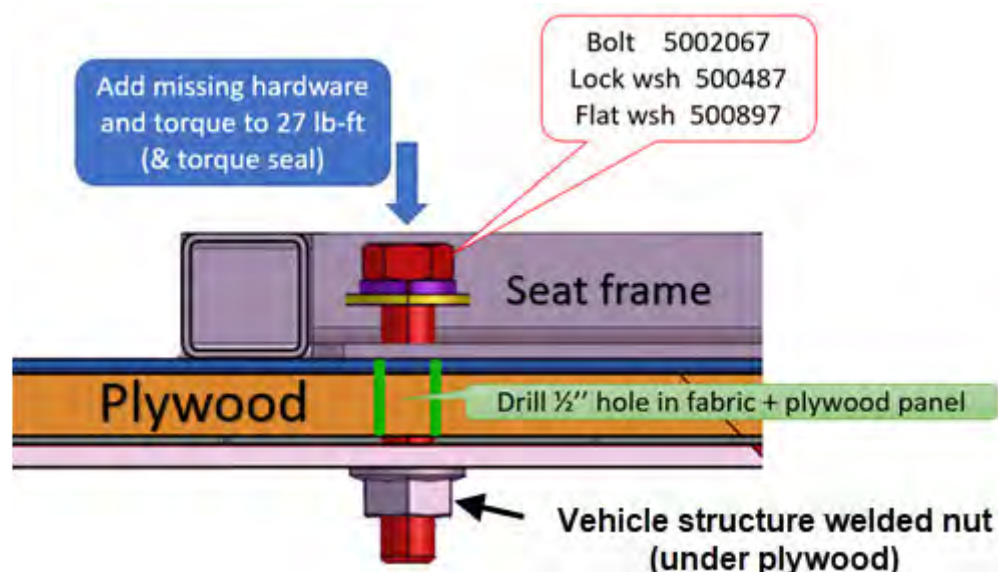

Figure4

WARRANTY

This modification is covered by Prevost's normal warranty. We will reimburse you the parts and 1/2 hour (0.5) of labor upon receipt of a completed A.F.A. Please submit claim via our Online Warranty System, available at www.prevostcar.com (under service \ warranty section). Use Claim Type: "Bulletin/Recall" and select "Safety Recall SR22-310".

Should you only wish to close the safety recall (without reimbursement), fill-in the "Safety Recall Certification Sheet" provided with this bulletin and return it to our warranty department by Email at prevost.onlinewarranty@volvo.com or by fax at 418-831-9301.

OTHER

VBC Bulletin	N/A
Fail Code	18.03-2
Defect Code	09
Syst.Cond	R
Causal Part	5002067

Access all our Service Bulletins on <http://techpub.prevostcar.com/en/> or scan the QR-Code with your smart phone.
E-mail us at technicalpublications_prev@volvo.com and type "ADD" in the subject to receive our warranty bulletins by e-mail.





**Safety Recall
Certification Sheet
(Ref: SR22-310)**

VEHICLE SERIAL NUMBER:

4	R	K																	
---	---	---	--	--	--	--	--	--	--	--	--	--	--	--	--	--	--	--	--

PERFORMED BY		OWNER/OPERATOR	
We hereby certify that Safety Recall Instructions with regard to Safety Recall SR22-310 have been performed.			
Name: _____		Name: _____	
Addr: _____		Addr: _____	
Phone: _____		Phone: _____	
Fax: _____		Fax: _____	
Signature : _____	_____	Signature : _____	_____
Date: _____	_____	Date: _____	_____

If the information mentioned above is incorrect or you are not the owner of this vehicle anymore, please fill this section and return to sender.

NEW OWNER:

BUSINESS:

ADDRESS (including County):

TELEPHONE: _____

FAX: _____

Please return this completed document with your A.F.A. form