



SAFETY RECALL BULLETIN

NHTSA RECALL 22V437

AUTOCAR, LLC SAFETY RECALL ACX-2203

July 2022

ATTENTION:

Service Managers / Parts Managers.

SUBJECT:

Autocar, LLC has determined that a defect which relates to motor vehicle safety exists in certain Xpeditor (ACX) chassis. The external fuse box may short circuit due to water intrusion.

SAFETY RECALL INFORMATION:

This Recall bulletin provides instructions regarding the relocation of the external fuse box and the installation of a debris shield.

VEHICLES AFFECTED:

There are 2143, 2019-2022 model year ACX (Xpeditor) chassis manufactured between March 13, 2019, and November 1, 2021, with non-sequential serial numbers in the range of 229795 through 237892. To determine if a vehicle is affected by this Recall, log in to the Autocar Warranty Management System at www.autocartruck.com. From the main menu, select "View Recalls/ Service Programs" and look for the Autocar Recall number above. A spreadsheet file will be accessible with the VIN list of affected vehicles. Alternatively, to determine if a single vehicle is affected, select "VIN Profile" from the main menu in the Autocar Warranty Management System. In the "Chassis Number" field, enter the last 6 of the VIN. Once the VIN profile is displayed, scroll down to the "Recall/Service Program Information" section to determine if the Recall is open.

SERVICE RESPONSIBILITY:

Service sites must perform this Recall on affected vehicles at no charge to the owner regardless of vehicle mileage, age, or ownership. If a vehicle affected by this Recall is taken into or is currently in your vehicle inventory, or at your center for service, you must perform this Recall before the vehicle is sold or released to the owner.



SAFETY RECALL BULLETIN

NHTSA RECALL 22V437

AUTOCAR, LLC SAFETY RECALL ACX-2203

July 2022

REQUIRED PARTS:

- (1) S8721024K001 Service Kit
 - (1) A8721276-001 Debris shield
 - (1) A8721289-001 Vertical bracket
 - (1) GZ220010-006 Three hole bracket
 - (1) S6610010-001 Cab tilt lever
 - (1) S8721025K001 Hardware kit
 - (1) 8500181 Flat washer
 - (5) 978435 Cable tie
 - (4) FE286225BW01 Locknut
 - (10) FE410125AW12 Bolt
 - (1) FE410137AW12 Bolt
 - (1) GZ040039-001 Wing nut
 - (1) GZ220044-001 Cable tie mount
 - (3) 220106-001 Cable tie edge mount

TO OBTAIN PARTS:

DO NOT submit a Solutions ticket. Verify that you have authorization from the customer to perform this work and send an e-mail to: warranty@autocartruck.com

1. VIN(s) (or) (last 6 digits of the VIN(s))
2. Attention To Name
3. Ship To Address

CLAIMS FOR REIMBURSEMENT:

Submit a claim for reimbursement in accordance with Autocar’s Warranty Administration Manual with the following claim coding information:

CLAIM CODING INFORMATION:

Repair Number (Op Code)	Time Allowance (SRT)	Description
36401-0-32	1.00 HR	External Fuse Box

Autocar, LLC
 4680 Pinson Valley Parkway
 Center Point, AL 35215
 888-218-3611

SAFETY RECALL BULLETIN

NHTSA RECALL 22V437

AUTOCAR, LLC SAFETY RECALL ACX-2203



July 2022

SAFETY NOTICES:



WARNING

Allow the vehicle's engine and cooling system to cool to ambient temperature before performing the repair procedure. A hot engine or cooling assembly may cause burns or other personal injury.



WARNING

Never rely on the hydraulic pressure to hold the cab in an open position. Always use the safety pin in the cab tilt lock tube to prevent serious personal injury or death.



WARNING

To prevent eye injury, always wear eye protection when performing vehicle maintenance, service or inspection.



WARNING

Before working on a vehicle, set the parking brake, place the transmission in neutral and block the wheels. Failure to do so can result in unexpected vehicle movement and can cause serious personal injury or death.

SAFETY RECALL BULLETIN

NHTSA RECALL 22V437

AUTOCAR, LLC SAFETY RECALL ACX-2203



July 2022

Working on CNG/LNG Trucks

SAFETY INSTRUCTIONS

If you store or dispense Compressed Natural Gas (CNG) or Liquefied Natural Gas (LNG), or if you work on CNG or LNG trucks, your location must be fully compliant with applicable codes, regulations and standards, including National Fire Protection Associate (NFPA) codes, Society of Automotive Engineers (SAE) standards, American National Standards Institute (ANSI) Natural Gas Vehicle (NGV) standards, the United States Code of Federal Regulations (CFR) and your state and local fire and other applicable codes (including, for example, the California Code of Regulations and the Texas Administrative Code).

Contact your local fire department for guidance and additional compliance information.

Technicians working on Autocar trucks with CNG or LNG engines must be trained in the proper repair of CNG and LNG trucks and engines and the safe storage and dispensing of CNG and LNG.

Working on CNG Fuel Systems



WARNING

CNG fuel systems include a high pressure (3600 psi) system for fuel storage and a low pressure system (125 psi) for consumption by the engine. Understanding the characteristics of CNG and how the fuel system works will prevent injury and damage to persons and property.

Attempting to operate or maintain any CNG fuel system without proper training is dangerous. Complete training and consult instructional bulletins from the CNG system suppliers, such as Agility Fuel Systems' Field Service Bulletin, *Safely Working on CNG Fuel Systems*.

Welding and Hot Work Near CNG and LNG Trucks



WARNING

Welding, grinding, and other "hot work" can be safely performed on or near a CNG or LNG vehicle, but certain precautions must be followed. Understand and perform the necessary precautions provided by the CNG system suppliers, such as Agility Fuel Systems' Field Service Bulletin, *Welding and Hot Work Precautions Near CNG and LNG Vehicles*.



SAFETY RECALL BULLETIN

NHTSA RECALL 22V437

AUTOCAR, LLC SAFETY RECALL ACX-2203

July 2022

CNG Cylinders



WARNING

CNG fuel containers must meet Federal Motor Vehicle Safety Standard (FMVSS) 304 (Compressed Natural Gas Fuel Container Integrity) and/or ANSI/CSANGV2 (Basic Requirements for Compressed Natural Gas Vehicle Fuel Containers). Both standards specify a detailed visual examination every three years.

Truck owners are required to complete all necessary inspections, in accordance with the applicable standards and other resources, such as the Clean Vehicle Education Foundation and NGVAmerica's Compressed Natural Gas (CNG) Container Visual Inspection Advisory.

FMVSS 304 also requires that cylinders not be used after the end of life (EOL) date provided on the tank label. The EOL date is also displayed in the engine compartment and at the fueling connection of each truck. If there are any question as to proper decommissioning of a cylinder, contact the manufacturer, whose name and address is also required to be on the label.

CNG Fuel Container Pressure Relief Devices (PRDs)



WARNING

PRDs must be properly maintained and positioned for safe operation of a CNG fuel system. Missing vent caps can allow moisture into PRDs and vent lines, which can freeze and damage these safety components. Debris which clogs the PRDs and/or vent lines can prevent proper function.

PRDs must be positioned to vent upward, not outward, from a vehicle.

Ensure that every truck owner completes periodic inspections of the PRDs and vent lines and systems, in accordance with guidance provided by the system component suppliers.

Alert First Responders to CNG and LNG



DANGER

In the event of a fire or other emergency, alert first responders to the presence and location of CNG fuel systems, tanks and dispensers. Ensure that emergency personnel are aware of proper precautions, such as those provided in Agility's *First Responder Guide: CNG and LNG Vehicle Fuel Systems*.

SAFETY RECALL BULLETIN

NHTSA RECALL 22V437

AUTOCAR, LLC SAFETY RECALL ACX-2203



July 2022

LOCKOUT/TAGOUT PROCEDURES:



CAUTION

Before entering the vehicle or vehicle body, read and follow OSHA regulations concerning entry and working in “CONFINED SPACE” OSHA 1910.146 and “LOCKOUT/TAGOUT” OSHA 1910.147. Follow OSHA regulations while performing any work on the vehicle. The vehicle must be disabled by the following steps before performing any work on the vehicle:

1. Place the transmission in NEUTRAL.
2. Set the parking brake.
3. Shut the engine OFF.
4. Lock cab doors, keep the key in your pocket. Block the wheels before entering the body or performing any work on the vehicle.
5. Turn the battery disconnect switch OFF, if equipped.
6. Completely drain the air from the primary/A system and secondary/B system by opening the drain valves on the air tanks themselves or by using the drain manifold if supplied. When draining the air tanks, do not look into the area where air is draining. Dirt or sludge particles may be expelled in the air stream and can cause eye injury.
7. Place magnetic “DANGER” signs on both cab doors before entering the body or performing any work on the vehicle.
8. Take proper precautions before working under the vehicle. Use ramps approved for the weight of your vehicle, or use floor jacks and stands. Never work under a vehicle supported by jacks alone. Always use jack stands to support the vehicle.

SAFETY RECALL BULLETIN

NHTSA RECALL 22V437

AUTOCAR, LLC SAFETY RECALL ACX-2203



July 2022

FUSE BOX MOUNTING INSTRUCTIONS:

1. Follow all lockout/tagout procedures and verify the battery disconnect switch is in the “OFF” position. If the unit is not equipped with a battery disconnect switch, disconnect the battery cables beginning with the negative cables, followed by the positive cables.
2. Locate the external fuse box on the outboard side of the right upright (see Figure 1).

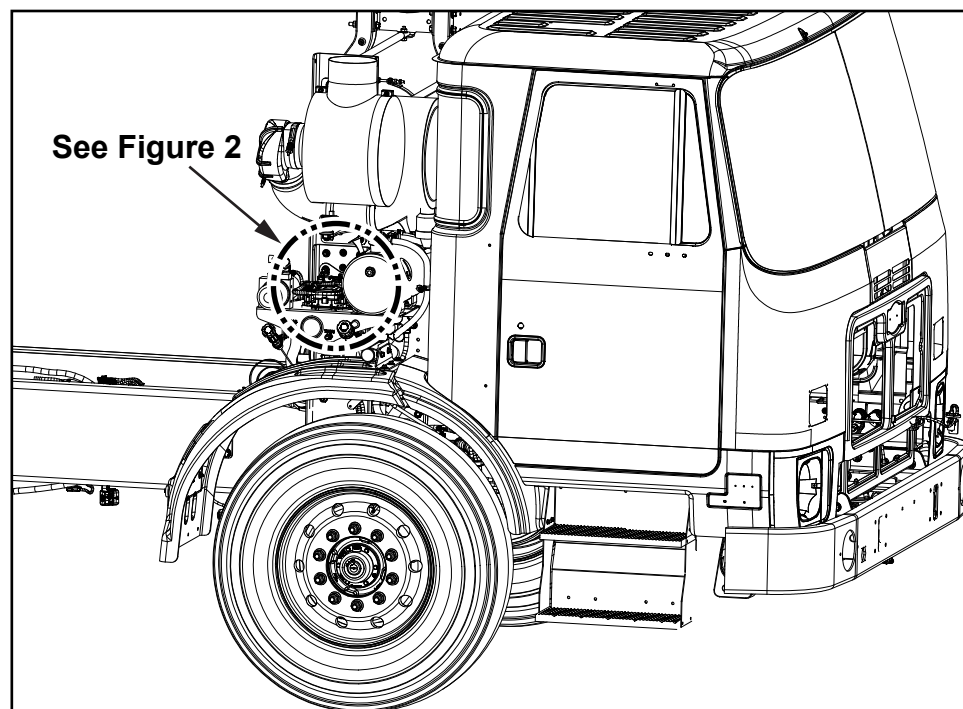

Figure 1

SAFETY RECALL BULLETIN

NHTSA RECALL 22V437

AUTOCAR, LLC SAFETY RECALL ACX-2203



July 2022

3. Locate the external fuse box, remove and discard the four mounting fasteners (see Figure 2).

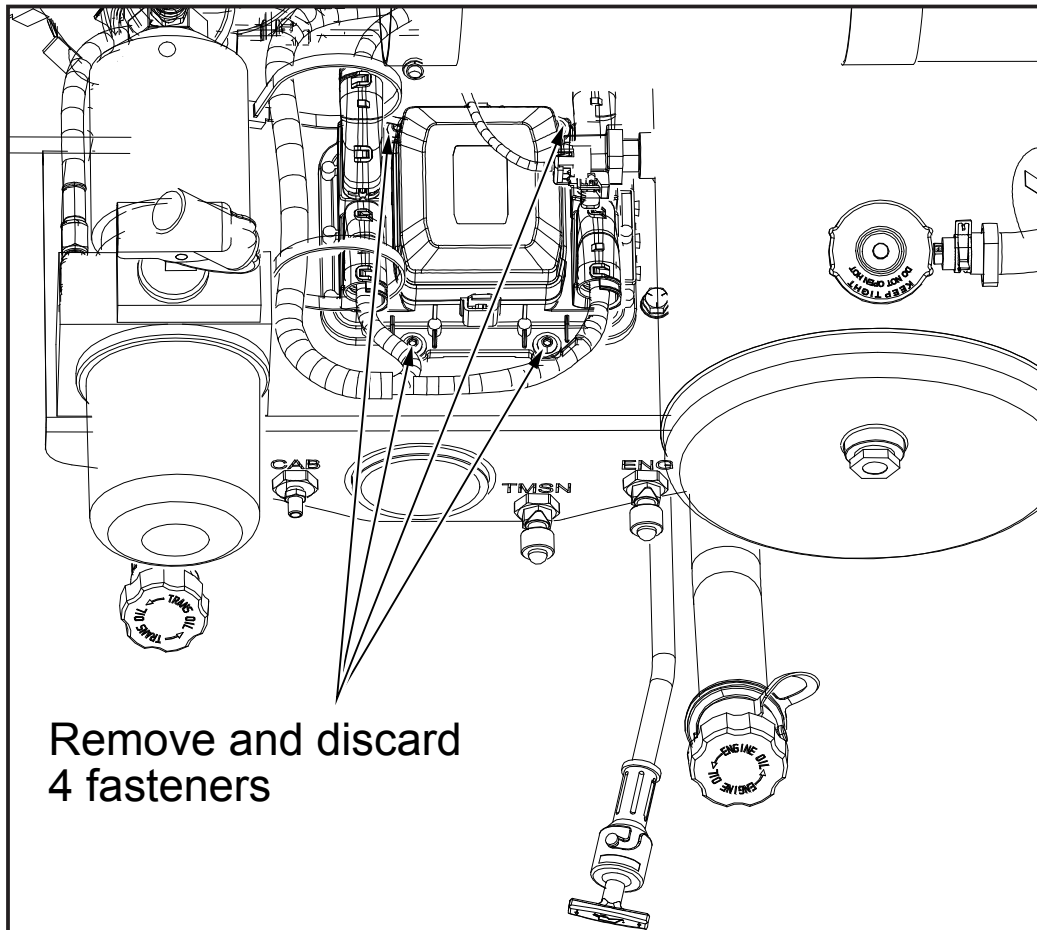

Figure 2

SAFETY RECALL BULLETIN

NHTSA RECALL 22V437

AUTOCAR, LLC SAFETY RECALL ACX-2203



July 2022

- Using three FE410125AW12 Bolts, install the A8721289-001 Vertical Bracket (see Figure 3).

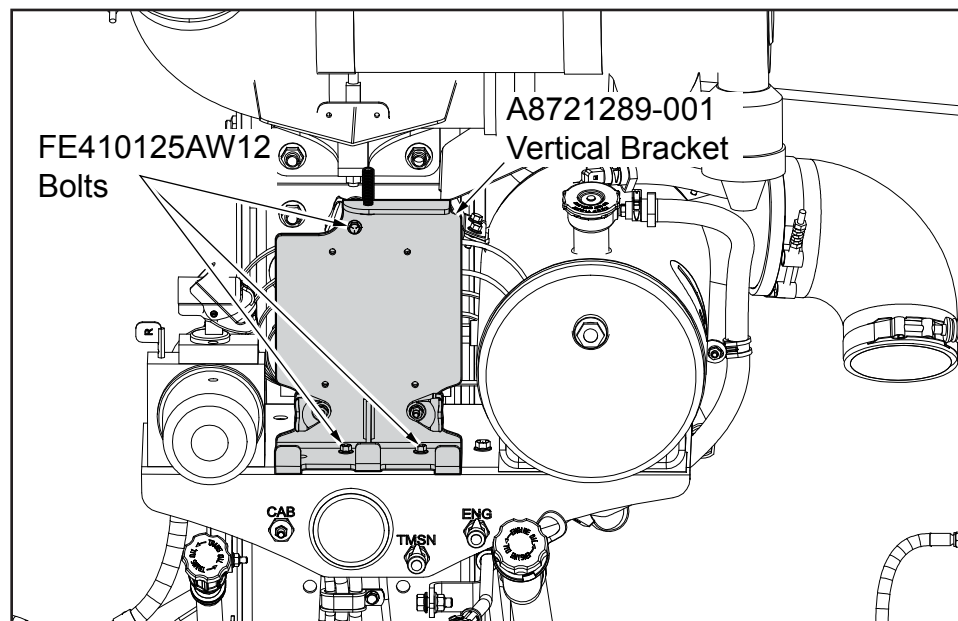

Figure 3

SAFETY RECALL BULLETIN

NHTSA RECALL 22V437

AUTOCAR, LLC SAFETY RECALL ACX-2203



July 2022

5. Install three 220106-001 Cable Tie Edge Mounts onto the Vertical Bracket and four 978435 Cable Ties (see Figure 4).
6. Install four FE410125AW12 Bolts and three FE286225BW01 Locknuts (see Figure 4).

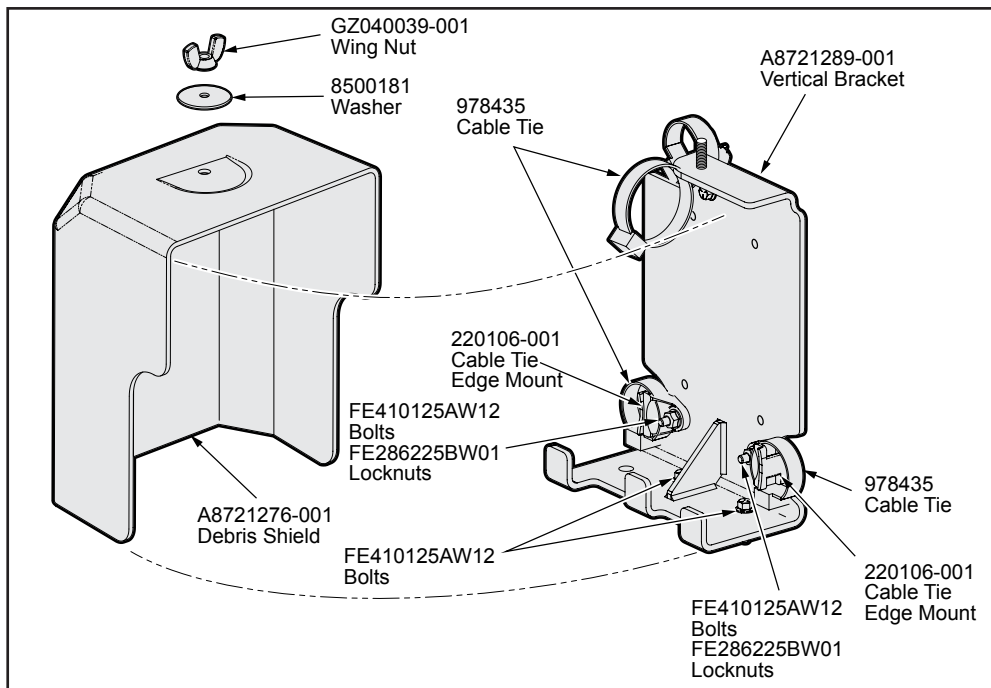

Figure 4

SAFETY RECALL BULLETIN

NHTSA RECALL 22V437

AUTOCAR, LLC SAFETY RECALL ACX-2203

July 2022

- Install the GZ220010-006 Three Hole Bracket and two FE410125AW12 Bolts. Install FE286225BW01 Locknut and GZ220044-001 Cable tie mount with 978435 Cable tie and FE410137AW12 Bolt. Route and secure harnesses as illustrated (see Figures 5 and 6).

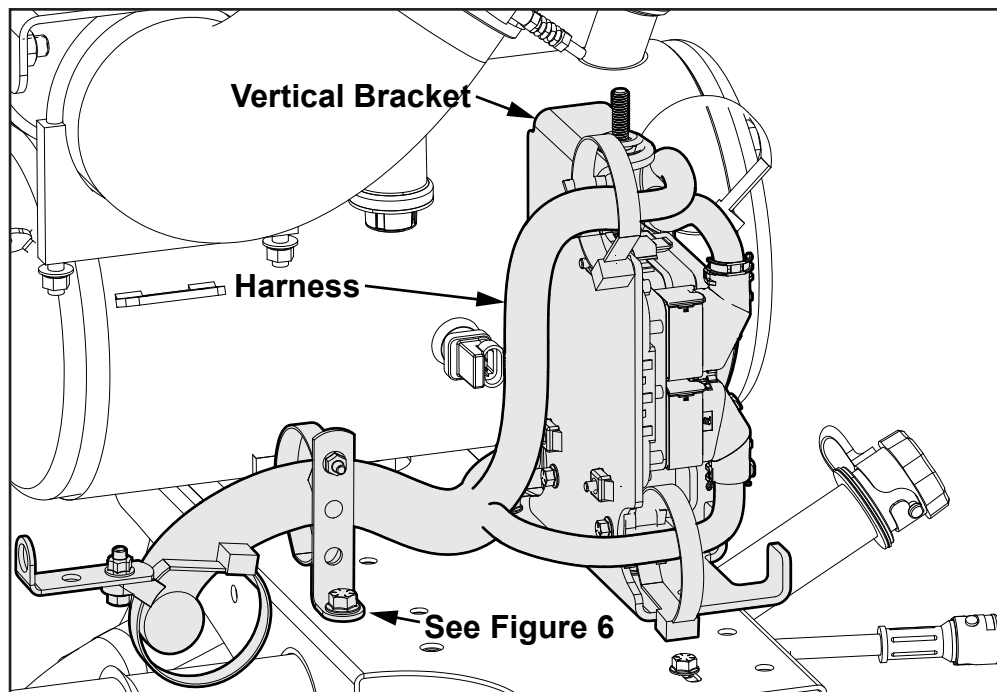

Figure 5

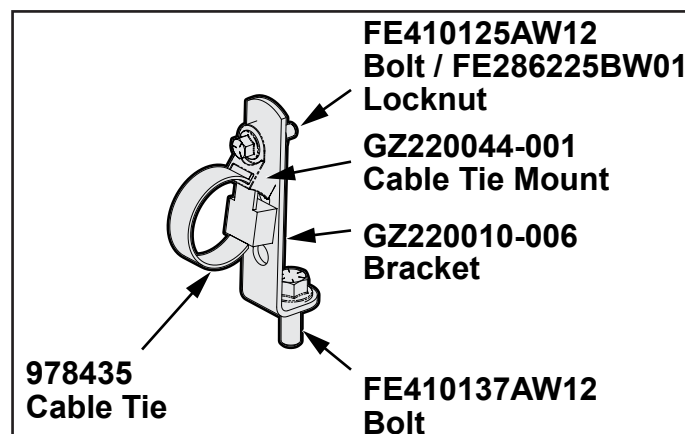

Figure 6

SAFETY RECALL BULLETIN

NHTSA RECALL 22V437

AUTOCAR, LLC SAFETY RECALL ACX-2203



July 2022

8. Using four FE410125AW12 Bolts, reinstall the FB3 Fuse Box (see *Figure 7*).
9. Install the new A8721276-001 Debris Shield, 8500181 Flat Washer and the GZ040039-001 Wing Nut (see *Figure 4*).

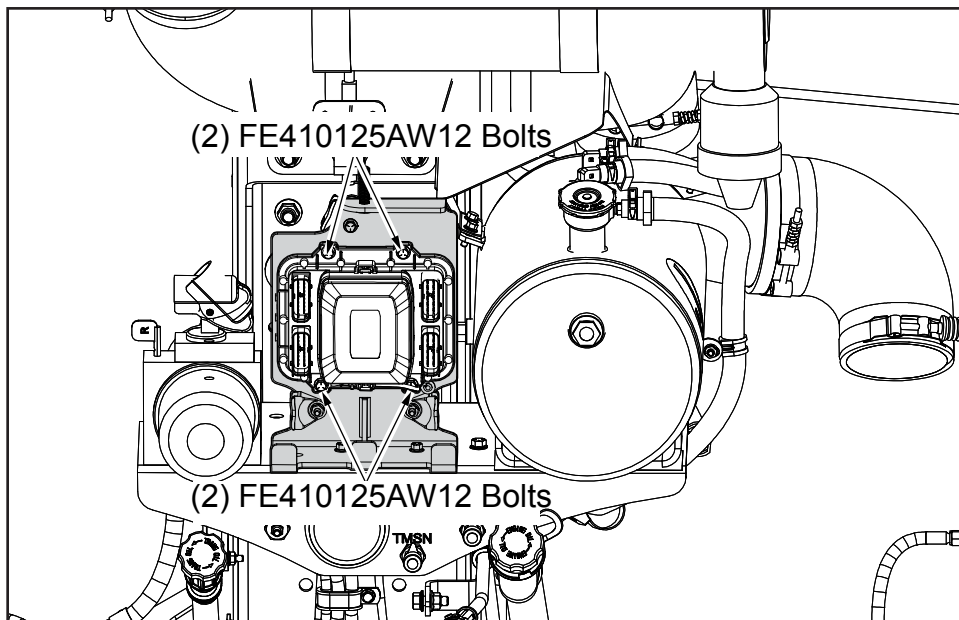

Figure 7

10. Locate the 2.75" Cab Tilt Level, remove and discard (see *Figure 8*).

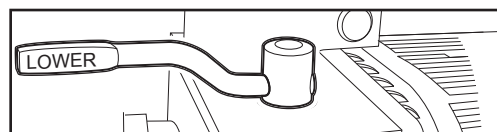

Figure 8

SAFETY RECALL BULLETIN

NHTSA RECALL 22V437

AUTOCAR, LLC SAFETY RECALL ACX-2203



July 2022

11. Install the 1" S6610010-001 Cab Tilt Lever (see Figure 9).

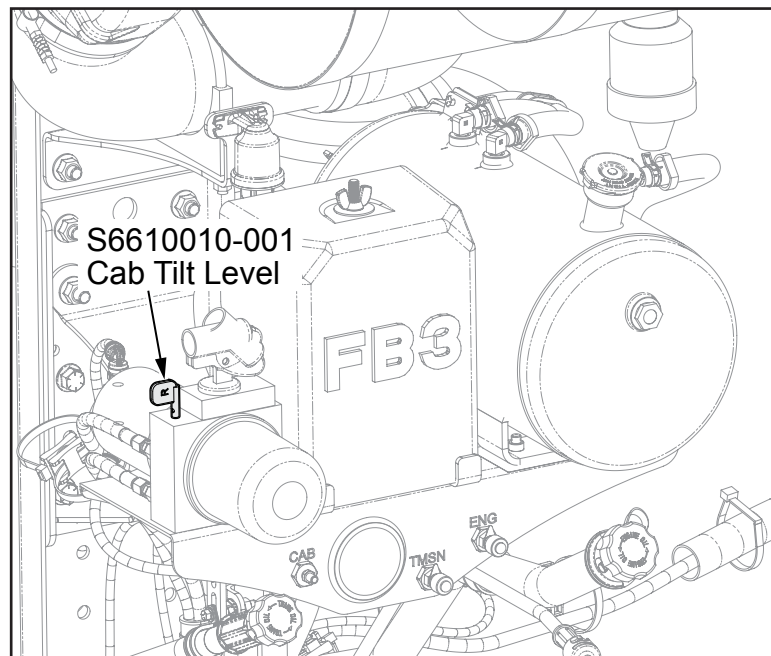

Figure 9

12. Turn on the battery disconnect switch or re-connect the battery cables beginning with the positive connections followed by the negative connections.
13. Installation is complete.

Note: if you have questions or concerns regarding this Safety Recall, please contact Autocar technical support at 888-218-3611.