



S&B FILTERS

**INSTALLATION INSTRUCTIONS FOR RECALL RELATED TO
S&B Diesel Fuel Tank Installed On
2005-2022 5.9L, 6.7L 2500-3500 Trucks
NHTSA ID 22E069**

Reason for Vent Link Modification:

At some point, Ram started using a larger driveline on MEGA Cab Models which positioned it closer to the S&B Tank. In a hot climate with close to a full tank of diesel fuel, the S&B Tank can swell outward making contact with the driveline. As a result, fuel may leak and increase the risk of fire and injury. The following instructions will add additional vapor space and prevent the tank from being overfilled. Visit www.sbfilters.com/10-1021recall to view the installation video.

Step 1. Confirm Adequate Space Between Tank & Driveline:

Use black plastic feeler gauge to check clearance between the tank and driveline forward of the front strap. If you are not able to get the feeler gauge between the tank and the driveline as shown in the image below, please email us a picture at recall@sbfilters.com.



STEP 2:

Use a hose cutter to cut the 5/16" fuel line (approximately in the middle) that connects one side of the tank to the other.

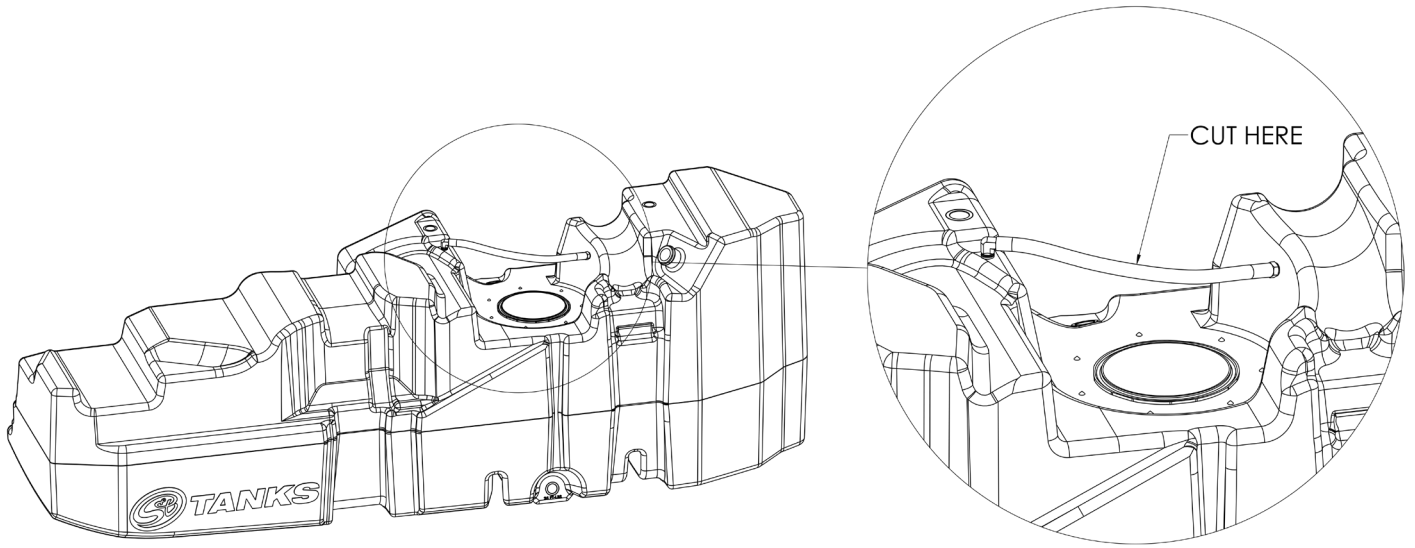

STEP 3:

Insert the included 5/16" white plugs into each end of the hose you just cut in step 2.

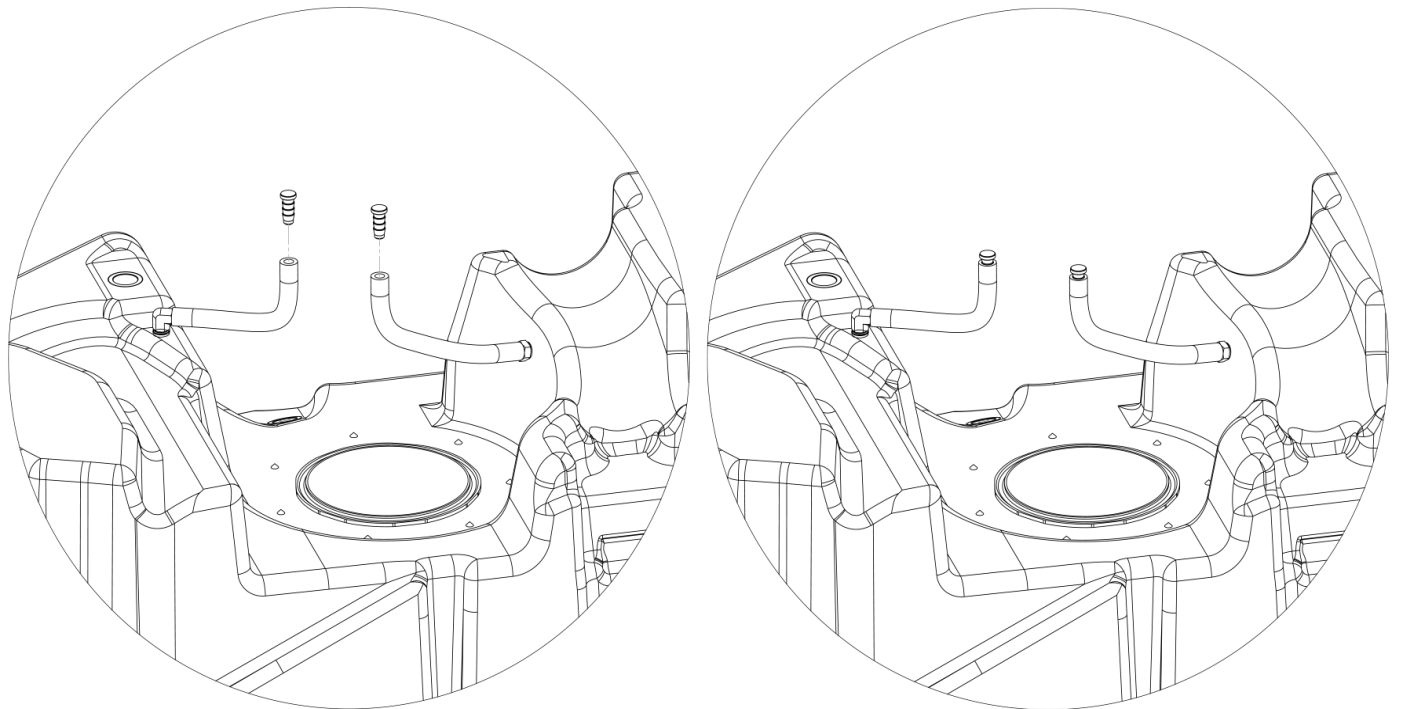

STEP 4:

Install Extension Vent Line: Find the 5/16" vent link that is connected to the top of the tank as shown on item 12 on the exploded view. Cut or remove the breather cap and install the insured S&B 5/16" extension hose. Zip tie to the filler neck so it is sloped upward.

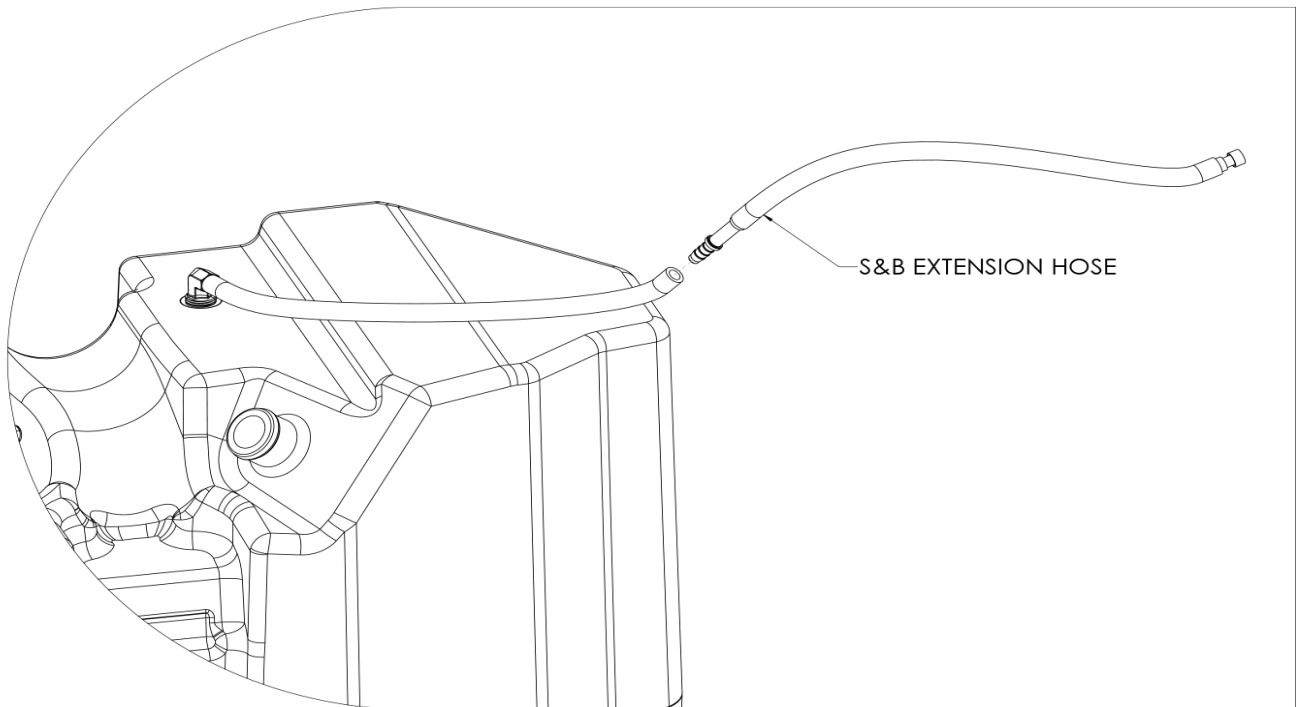
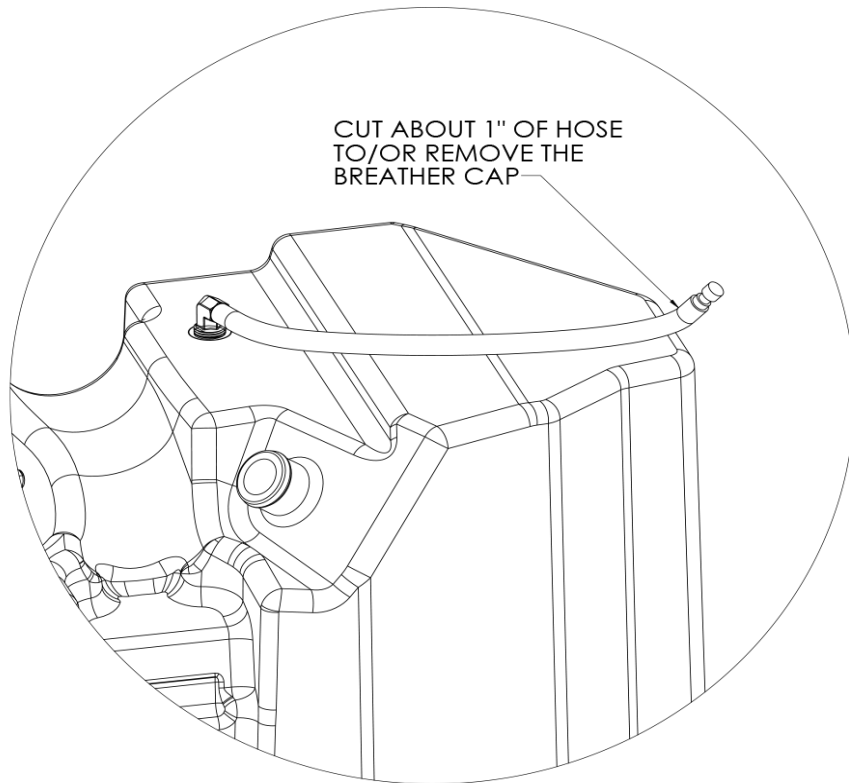

S&B apologizes for any inconvenience this has caused. If you did the installation yourself, please visit www.sbfilters.com/10-1021recall and click on "**Claim Your \$150 Install Fee**" where you will provide your vin and upload an image showing steps 3 & 5 were completed.