



January 2022

Dealer Service Instructions for:

Safety Recall Y99 / NHTSA 21V-925 Side Air Bag Inflatable Curtain Inflator

Remedy Available

2021 (DS) Ram 1500 Pickup
2021 - 2022 (DJ) Ram 2500 Pickup
2021 - 2022 (D2) Ram 3500 Pickup

NOTE: Some vehicles above may have been identified as not involved in this recall and therefore have been excluded from this recall.

IMPORTANT: Some of the involved vehicles may be in dealer new vehicle inventory. Federal law requires you to complete this recall service on these vehicles before retail delivery. Dealers should also consider this requirement to apply to used vehicle inventory and should perform this recall on vehicles in for service. Involved vehicles can be determined by using the VIP inquiry process.

Subject

The Side Air Bag Inflatable Curtain (SABIC) on about 168 of the above vehicles may have been built with an inflator with out of specification propellant gas mass. SABIC assemblies with low gas mass may result in non-deployment or low/slow deployment and high gas mass may result in aggressive deployment of the air bag, which may increase the risk of occupant injury in certain crashes.

Repair

Identify the VIN below and the SABIC required to be replaced.

VIN Last 8	Part Number	VIN Last 8	Part Number
MG524991	CSSLY551AA	MS554070	CSSLY553AA
MG540074	CSSLY551AA	MS555974	CSSLY553AA
MG544845	CSSLY552AA	MS556393	CSSLY554AA
MG546488	CSSLY551AA	MS559607	CSSLY553AA
MG554203	CSSLY551AA	MS562158	CSSLY554AA
MG555753	CSSLY551AA	MS566993	CSSLY553AA
MG556416	CSSLY552AA	MS568280	CSSLY553AA
MG558077	CSSLY551AA	MS568357	CSSLY554AA
MG558482	CSSLY551AA	MS568799	CSSLY553AA
MG558730	CSSLY552AA	MS571265	CSSLY553AA
MG558894	CSSLY551AA	MS571843	CSSLY554AA
MG559513	CSSLY551AA	MS572731	CSSLY553AA
MG560025	CSSLY551AA	MS573495	CSSLY553AA
MG560657	CSSLY552AA	MS573564	CSSLY553AA
MG565325	CSSLY552AA	MS573609	CSSLY553AA
MG566324	CSSLY551AA	MS576542	CSSLY553AA
MG566610	CSSLY552AA	MS578249	CSSLY553AA
MG566649	CSSLY552AA	MS579970	CSSLY553AA
MG566927	CSSLY551AA	MS580055	CSSLY553AA
MG567112	CSSLY551AA	MS581740	CSSLY553AA
MG568201	CSSLY555AA	MS582077	CSSLY553AA
MG569653	CSSLY551AA	MS584054	CSSLY554AA
MG570090	CSSLY551AA	MS587367	CSSLY551AA
MG572814	CSSLY555AA	MS590551	CSSLY553AA
MG575106	CSSLY552AA	MS590590	CSSLY553AA
MG580367	CSSLY552AA	MS591161	CSSLY551AA
MG580733	CSSLY558AA	MS591827	CSSLY553AA
MG589049	CSSLY552AA	MS591986	CSSLY553AA
MG594990	CSSLY551AA	MS592087	CSSLY551AA
MG596681	CSSLY552AA	MS593244	CSSLY554AA
MG598115	CSSLY552AA	MS593705	CSSLY553AA
MG600612	CSSLY552AA	MS597484	CSSLY554AA
MG603806	CSSLY555AA	NG101362	CSSLY552AA
MG611105	CSSLY552AA	NG101450	CSSLY551AA
MG614665	CSSLY551AA	NG106572	CSSLY552AA
MG619324	CSSLY552AA	NG107256	CSSLY551AA
MG631124	CSSLY552AA	NG108368	CSSLY551AA
MG637698	CSSLY558AA	NG110666	CSSLY552AA
MG642346	CSSLY551AA	NG111622	CSSLY551AA
MG642790	CSSLY551AA	NG113373	CSSLY558AA
MG646357	CSSLY556AA	NG119202	CSSLY552AA
MG652409	CSSLY552AA	NG119305	CSSLY551AA

VIN Last 8	Part Number
MG654286	CSSLY552AA
MG654797	CSSLY552AA
MG658654	CSSLY552AA
MG660248	CSSLY552AA
MG660513	CSSLY552AA
MG666698	CSSLY552AA
MG667795	CSSLY552AA
MG670405	CSSLY551AA
MG675303	CSSLY551AA
MG678096	CSSLY552AA
MG678180	CSSLY551AA
MG678222	CSSLY552AA
MG678267	CSSLY552AA
MG679160	CSSLY552AA
MG679361	CSSLY552AA
MG681112	CSSLY552AA
MG681283	CSSLY552AA
MG684934	CSSLY557AA
MG689048	CSSLY552AA
MG690540	CSSLY552AA
MG697264	CSSLY551AA
MG709179	CSSLY551AA
MG711750	CSSLY551AA
MG711844	CSSLY552AA
MG714780	CSSLY551AA
MS509635	CSSLY551AA
MS522633	CSSLY551AA
MS528185	CSSLY551AA
MS528606	CSSLY551AA
MS528819	CSSLY551AA
MS530472	CSSLY551AA
MS531818	CSSLY551AA
MS532121	CSSLY552AA
MS532304	CSSLY552AA
MS532422	CSSLY552AA
MS532856	CSSLY551AA
MS538347	CSSLY554AA
MS545039	CSSLY554AA
MS546845	CSSLY553AA
MS551031	CSSLY554AA
MS551194	CSSLY553AA
MS553358	CSSLY551AA

Service Procedure

Follow the specific service procedure below for the vehicle being serviced:

A. Standard Cab – Page 6

B. Quad Cab – Page 17

C. Crew Cab – Page 36

D. Mega Cab – Page 53

Service Procedure [Continued]

A. Standard Cab

1. Using a small flat-bladed tool, carefully open the two fastener covers (3) located in the A-pillar trim panel (2) (Figure 1).
2. Remove the two bolts (4) that secure the A-pillar trim panel to the A-pillar (1) and remove the trim panel (Figure 1).

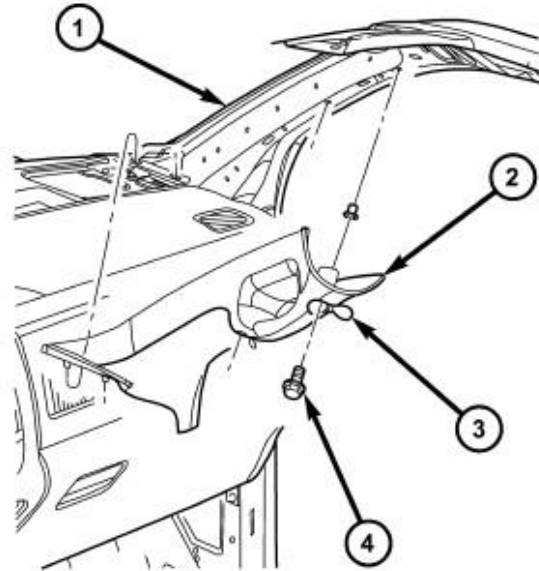

80d407a9

Figure 1 – A-Pillar

3. Push in the buttons on front seat headrest sleeves then pull the headrest up and remove (Figure 2).

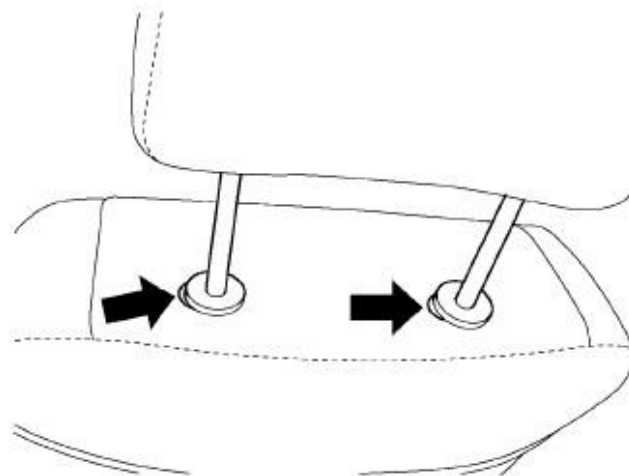

812oddd3

Figure 2 – Front Seat Head Rest

4. Fold the seats forward.

Service Procedure [Continued]

5. Release the upper retaining clips of the B-pillar lower trim panel to allow for removal of the B-pillar upper trim panel (Figure 3).



Figure 3 – B-Pillar Lower Trim Panel

6. Separate the seatbelt turning loop cover then remove the turning loop bolt (Figure 4).

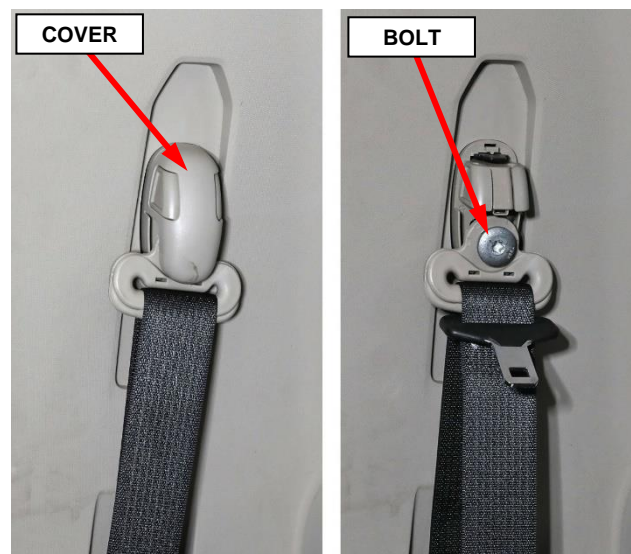

Figure 4 – Seat Belt Turning Loop

Service Procedure [Continued]

7. Using a trim stick or equivalent, release the B-pillar airbag applique then remove the screw that secures the upper trim panel (Figure 5).

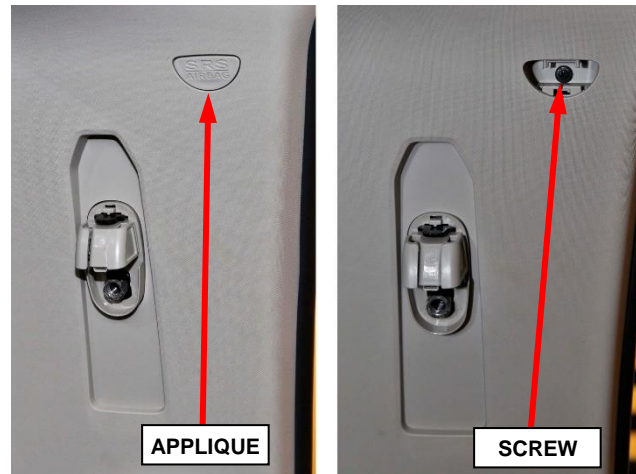

Figure 5 – B-Pillar Upper Trim Panel Fastener

8. Release the retaining clips and remove the B-pillar upper trim panel (1) (Figure 6).

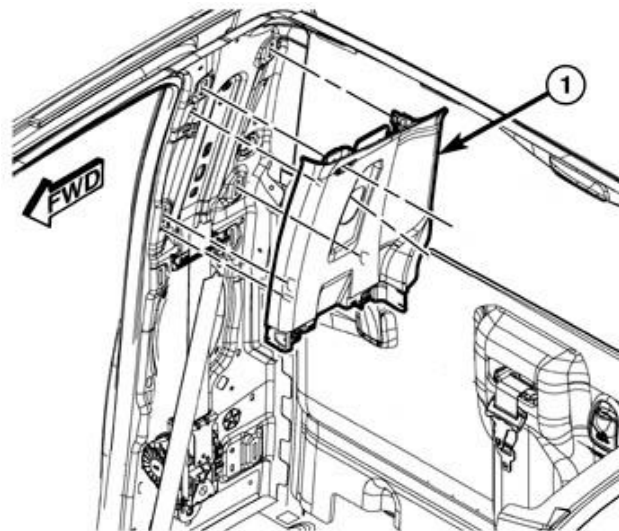

Figure 6 – B-Pillar Upper Trim Panel

9. Recline seat backs rearward to allow for room to lower the headliner.

Service Procedure [Continued]

10. Disconnect and isolate the negative battery cable. If equipped with an Intelligent Battery Sensor (IBS), disconnect the IBS connector first before disconnecting the negative battery cable. Wait two minutes for the system capacitor to discharge before further service.

WARNING: To avoid serious or fatal injury on vehicles equipped with airbags, disable the Supplemental Restraint System (SRS) before attempting any steering wheel, steering column, airbag, seat belt tensioner, impact sensor or instrument panel component diagnosis or service. Disconnect and isolate the battery negative (ground) cable, then wait two minutes for the system capacitor to discharge before performing further diagnosis or service. This is the only sure way to disable the SRS. Failure to take the proper precautions could result in accidental airbag deployment.

WARNING: To avoid serious or fatal injury when removing a deployed airbag, rubber gloves, eye protection, and a long-sleeved shirt should be worn. There may be deposits on the airbag unit and other interior surfaces. In large doses, these deposits may cause irritation to the skin and eyes.

WARNING: To avoid serious or fatal injury, use extreme care to prevent any foreign material from entering the side curtain airbag, or becoming entrapped between the side curtain airbag cushion and the headliner. Failure to observe this warning could result in occupant injuries upon airbag deployment.

NOTE: The following procedure is for replacement of an ineffective or damaged side curtain airbag (also known as Side Air Bag Inflatable Curtain/SABIC). If the airbag is ineffective or damaged, but not deployed, review local ordinances regarding recommended procedures for handling and disposal of Non-Deployed Supplemental Restraints.

NOTE: If a side curtain airbag is being removed, but has not been deployed, the headliner does not need to be removed from the passenger compartment. Lowering the headliner and resting it on the seat backs will allow enough clearance to remove the side curtain airbag from the vehicle.

Service Procedure [Continued]

CAUTION: Hands should be clean or clean cloth gloves used when handling the visors and headliner to avoid marks or damage.

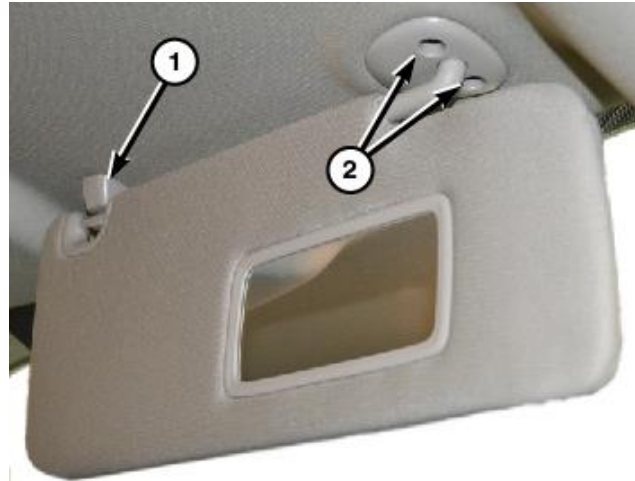

Figure 7 – Visors

11. Separate the visor from the support (1) then remove the screw and remove the visor support (Figure 7).

12. Remove the visor screws (2) then remove the visor (Figure 7).

Using a small flat bladed tool or equivalent, release the retaining tabs (1) and separate the visor from the headliner (Figure 8).

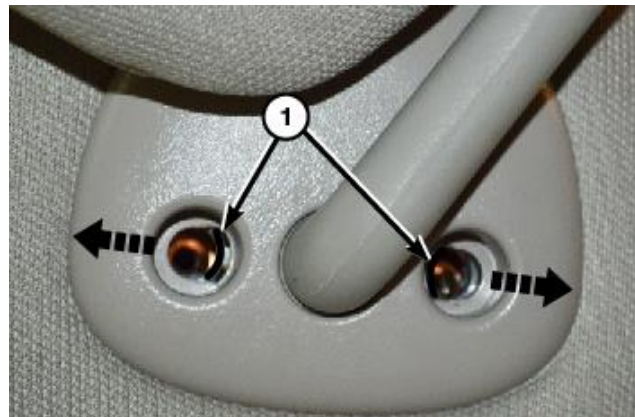

Figure 8 – Visors

13. Disconnect the visor electrical connector if equipped.

NOTE: In some cases, the wire harness for the visor vanity mirror may be glued to the top side of the headliner and may be a little difficult to release.

14. Using a small flat bladed tool, open the coat hook screw cover (2) then remove the screw and coat hook (Figure 9).

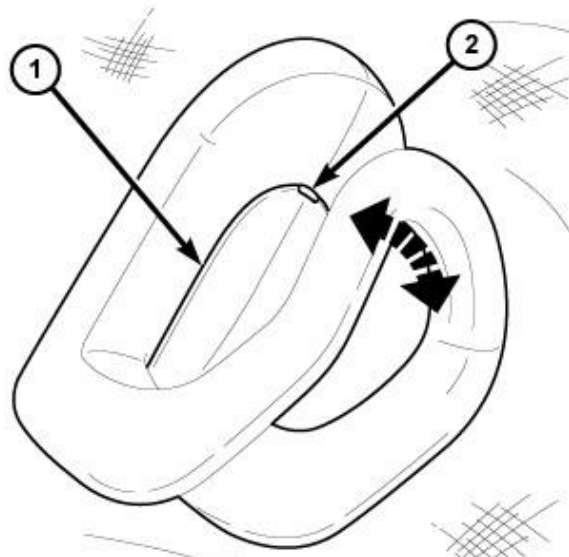

Figure 9 – Coat Hook

Service Procedure [Continued]

15. As necessary, release the headliner wiring harness clips (3) from the A-pillar to allow enough wiring harness slack for lowering the headliner (Figure 10).

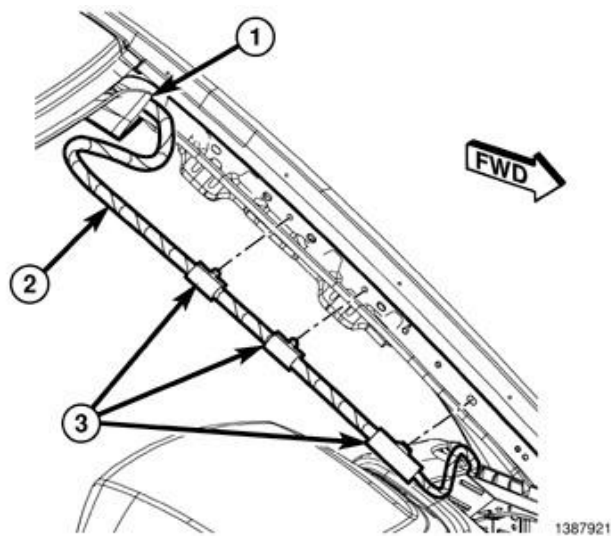

Figure 10 – Headliner Harness

16. Release the door seals from the door openings in order to allow for lowering of the headliner.

17. Carefully lower the headliner allowing it to rest on the seat backs and instrument panel (Figure 11).

CAUTION: Disconnect any wiring harness electrical connectors as necessary to allow enough wiring harness slack for lowering headliner. It will not be necessary to remove the headliner from the vehicle.

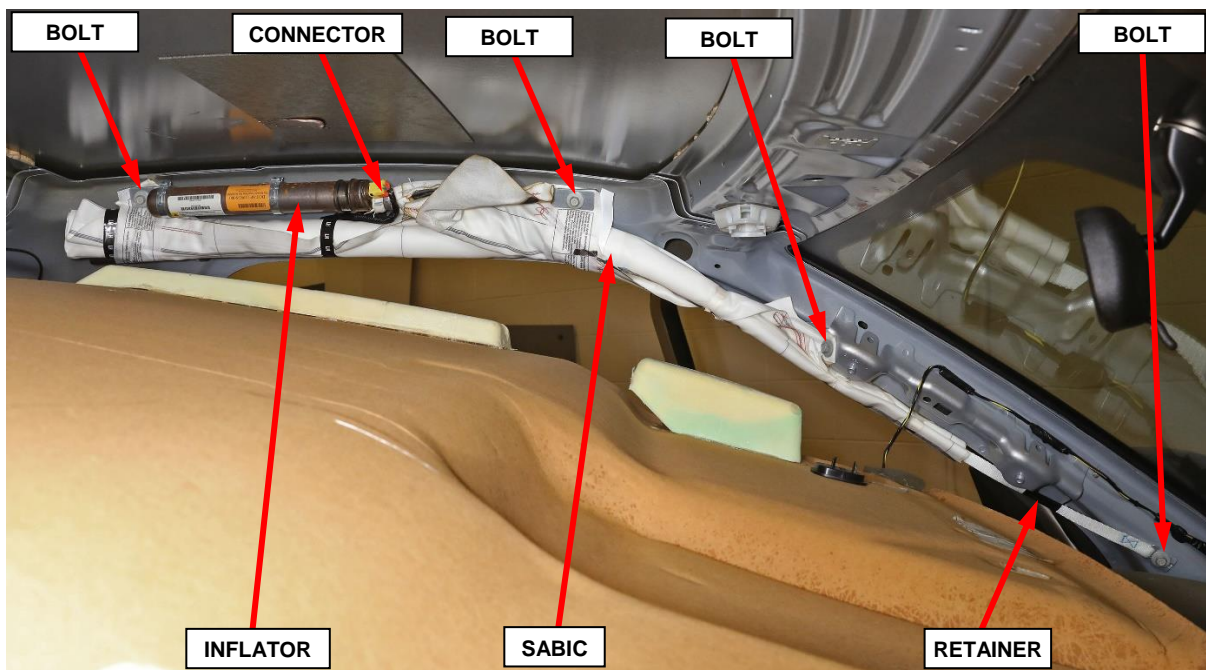

Figure 11 – Headliner

18. Obtain the appropriate replacement SABIC(s) for the vehicle based on its VIN.

Service Procedure [Continued]

19. The body wire harness connector is secured by integral latches to the connector receptacle on the inflator. Pinch both latches firmly, then pull the connector straight out from the airbag inflator to disconnect it from the connector receptacle (Figure 12).
20. Remove the four bolts that secure the side curtain airbag to the inner roof rail and A-pillar (Figure 12).
21. Disengage the one plastic push-in retainer that secures the side curtain airbag tether to the inner A-pillar (Figure 12).
22. Slide the inflator rearward far enough to disengage the T-tab at the front of the inflator bracket from the keyed T-slot in the inner roof rail over the front door opening (Figure 13).
23. Remove the SABIC from the vehicle as a unit and **DISCARD** following local ordinances and recommended procedures for handling and disposal of non-deployed supplemental restraints. Provided packaging is not authorized for the transport of the recalled SABIC Module. Parts will need to be either deployed on-site or transported in alternative approved containers.

**Figure 12 – SABIC**

Service Procedure [Continued]

Figure 13 – SABIC Inflator T-Tab and Inner Roof Rail T-Slot

24. Check to be certain that the two spring nuts are properly installed in the inner roof rail and that they are in good condition.
25. Position the **NEW** SABIC into the vehicle as a unit (Figure 12).
26. Insert the T-tab at the front of the inflator bracket into the keyed T-slot in the inner roof rail over the front door opening and slide the inflator forward to engage it (Figure 13).
27. Ensure the tether is not twisted then engage the one plastic push-in retainer that secures the side curtain airbag front tether to the assist handle bracket on the inner A-pillar (Figure 12).
28. Working from rear to front, install and tighten the four bolts that secure the side curtain airbag to the inner roof rail and A-pillar. Tighten the bolts to 7 N·m (62 in. lbs.) (Figure 12).
29. Connect the body wire harness connector for the side curtain airbag to the connector receptacle of the inflator. Be certain that each connector is fully engaged in its receptacle by listening carefully for a distinct, audible click as the connector latches snap into place (Figure 12).

Service Procedure [Continued]

CAUTION: Hands should be clean or clean cloth gloves used when handling the headliner to avoid damage to the headliner.

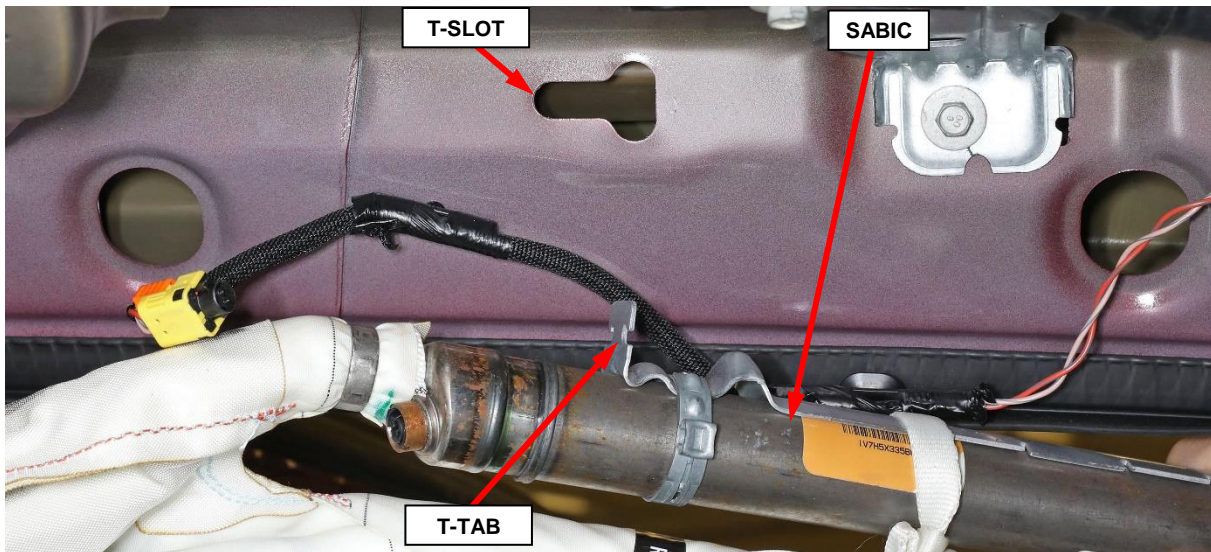
30. Raise the headliner into proper vehicle position and connect any electrical connectors previously disconnected from the headliner.

CAUTION: Be certain to avoid any wiring or drain tube interference.

31. Position the coat hooks (5) onto the headliner and install the screws tightening securely into the mounting clips then close the screw cap fully (Figure 9).
32. Position the visor supports (1) onto the headliner and install the screws into the mounting clips (Figure 7).
33. If equipped with illuminated vanity mirror, connect the wire harness connector.
34. Position the visor to the headliner and install the screws (2) that secure the visor to the roof panel. Tighten the screws to 6 N·m (53 in. lbs.) (Figure 7).
35. Reattach any headliner wiring harness clips (3) removed from the A-pillar to allow slack while lowering headliner (Figure 10).

WARNING: Do not connect the negative battery cable at this time. The Supplemental Restraint System (SRS) Verification Test procedure should be performed following service of any SRS component.

NOTE: The following procedure should be performed using a diagnostic scan tool to verify proper Supplemental Restraint System (SRS) operation following the service or replacement of any SRS component. Refer to the appropriate diagnostic procedures.

36. During the following test, the negative cable remains disconnected and isolated from the battery, as it was during the Supplemental Restraint System (SRS) component removal and installation procedures.

Service Procedure [Continued]

37. Be certain that the diagnostic scan tool contains the latest version of the proper diagnostic software. Connect the scan tool to the 16-way Data Link Connector (DLC). The DLC is located on the driver side lower edge of the instrument panel, near the steering column opening cover and outboard of the steering column.
38. Transition the status of the ignition switch (also known as the Keyless Ignition Node/KIN or IGnition Node Module/IGNM) to ON and exit the vehicle with the scan tool.
39. Check to be certain that nobody is in the vehicle, then connect the negative cable to the battery.
40. Using the scan tool, read and record the active (current) Diagnostic Trouble Code (DTC) data.
41. Next, use the scan tool to read and record any stored (historical) DTC data.
42. If any SRS related DTC is found in the previous two steps, refer to the appropriate diagnostic information.
43. Use the scan tool to erase the stored DTC data. If any problems remain, the stored DTC data will not erase. Refer to the appropriate diagnostic information to diagnose any stored DTC that will not erase. If the stored DTC information is successfully erased, continue to the next step.
44. Transition the status of the ignition switch to OFF for about 15 seconds, and then back to ON. Observe the airbag indicator in the instrument cluster. It should light from four to six seconds, and then go out. This indicates that the SRS is functioning normally and that the repairs are complete. If the airbag indicator fails to light, or lights and stays ON, there is still an active SRS fault or malfunction. Refer to the appropriate diagnostic information to diagnose the problem.
45. Raise the seat backs and position the seats forward.
46. Install the B-pillar upper trim panel (1) and engage the retaining clips fully (Figure 6).

Service Procedure [Continued]

47. Install and tighten the screw that secures the B-pillar upper trim panel then install the airbag applique cover (Figure 5).
48. Remove and **DISCARD** the bolt retainer and the bolt from the seat belt turning loop, save the spacer washer for reuse (Figure 14).
49. Using a **NEW** bolt and reusing the spacer washer, install the turning loop then tighten the bolt to 40 N·m (30 ft. lbs.) (Figure 4).
50. Install the turning loop cover (Figure 4).
51. Position the B-pillar lower trim panel and engage the retaining clips fully (Figure 3).

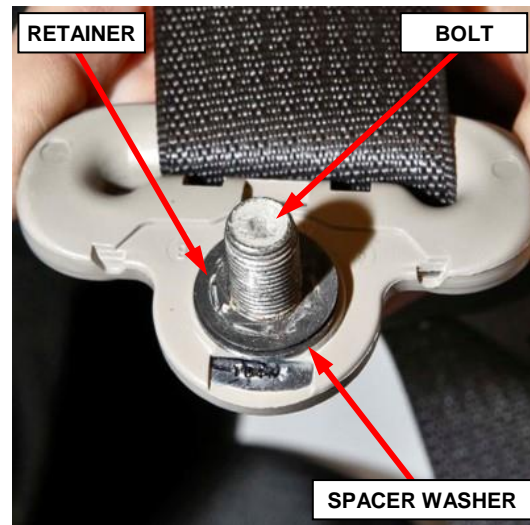
**Figure 14 – Headliner**

NOTE: Ensure that all B-pillar fasteners are installed/engaged properly.

52. Install the front seat headrests (Figure 2).
53. Position the locating tab of the A-pillar trim panel (2) into the slot located in the top of the instrument panel (Figure 1).
54. Install the A-pillar trim panel onto the A-pillar (1) and install the two bolts (4). Tighten the bolts to 5 N·m (44 in. lbs.) (Figure 1).
55. Close the two fastener covers (3) located in the A-pillar trim panel (Figure 1).
56. Install the door seals around the door openings.
57. Return the vehicle to the customer or inventory.

Service Procedure [Continued]

B. Quad Cab

1. Using a small flat-bladed tool, carefully open the two fastener covers (3) located in the A-pillar trim panel (2) (Figure 15).
2. Remove the two bolts (4) that secure the A-pillar trim panel to the A-pillar (1) and remove the trim panel (Figure 15).

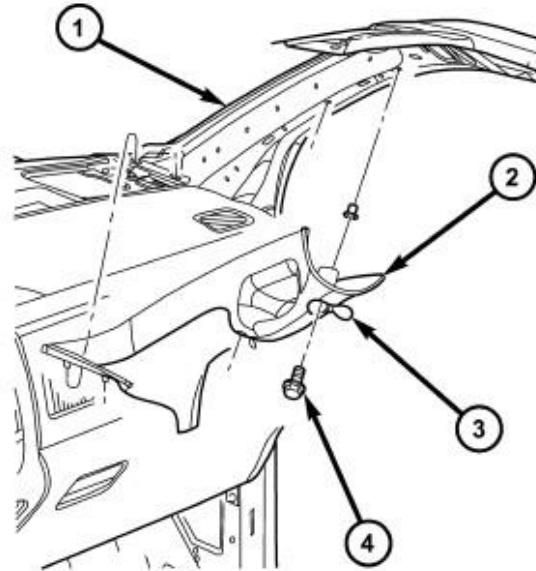

80d407a9

Figure 15 – A-Pillar

3. Push in the buttons on front seat headrest sleeves then pull the headrest up and remove (Figure 16).

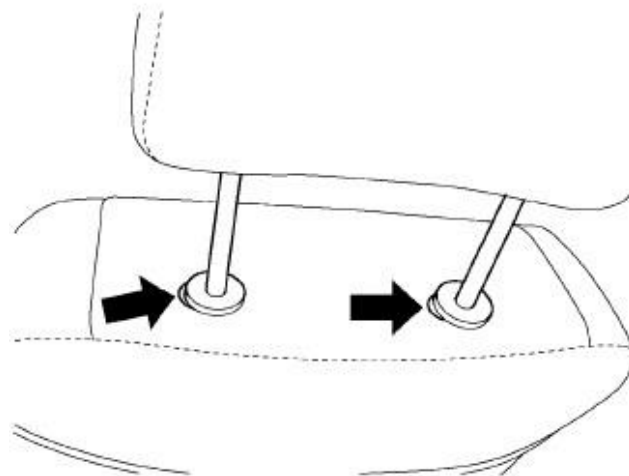

8120dd43

4. Position the front seats to the full forward position with the seat backs fully forward.

Figure 16 – Head Rest

Service Procedure [Continued]

5. Disconnect and isolate the negative battery cable. If equipped with an Intelligent Battery Sensor (IBS), disconnect the IBS connector first before disconnecting the negative battery cable. Wait two minutes for the system capacitor to discharge before further service.

WARNING: To avoid serious or fatal injury on vehicles equipped with airbags, disable the Supplemental Restraint System (SRS) before attempting any steering wheel, steering column, airbag, seat belt tensioner, impact sensor or instrument panel component diagnosis or service. Disconnect and isolate the battery negative (ground) cable, then wait two minutes for the system capacitor to discharge before performing further diagnosis or service. This is the only sure way to disable the SRS. Failure to take the proper precautions could result in accidental airbag deployment.

WARNING: To avoid serious or fatal injury when removing a deployed airbag, rubber gloves, eye protection, and a long-sleeved shirt should be worn. There may be deposits on the airbag unit and other interior surfaces. In large doses, these deposits may cause irritation to the skin and eyes.

WARNING: To avoid serious or fatal injury, use extreme care to prevent any foreign material from entering the side curtain airbag, or becoming entrapped between the side curtain airbag cushion and the headliner. Failure to observe this warning could result in occupant injuries upon airbag deployment.

NOTE: The following procedure is for replacement of an ineffective or damaged side curtain airbag (also known as Side Air Bag Inflatable Curtain/SABIC). If the airbag is ineffective or damaged, but not deployed, review local ordinances regarding recommended procedures for handling and disposal of Non-Deployed Supplemental Restraints.

NOTE: If a side curtain airbag is being removed, but has not been deployed, the headliner does not need to be removed from the passenger compartment. Lowering the headliner and resting it on the seat backs will allow enough clearance to remove the side curtain airbag from the vehicle.

Service Procedure [Continued]

6. If equipped with a subwoofer speaker, raise the right rear seat to access the subwoofer (2) (Figure 17).

7. Remove the subwoofer mounting fasteners (1) (Figure 17).

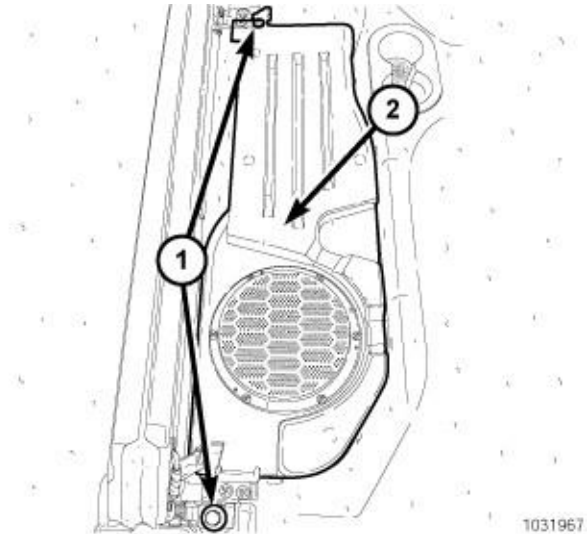

Figure 17 – Subwoofer

8. Disconnect the electrical connector and remove the subwoofer (2) (Figure 18).

NOTE: 60/40 bench seat shown, solid bench seat similar.

9. If equipped, disconnect the electrical connectors (1) under the rear seat (Figure 18).

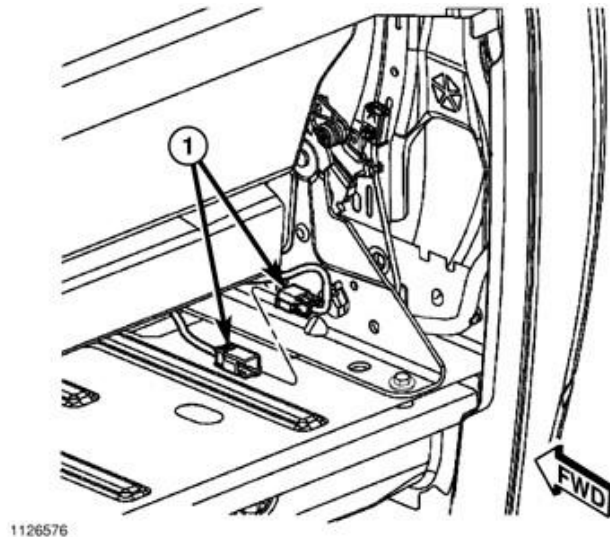
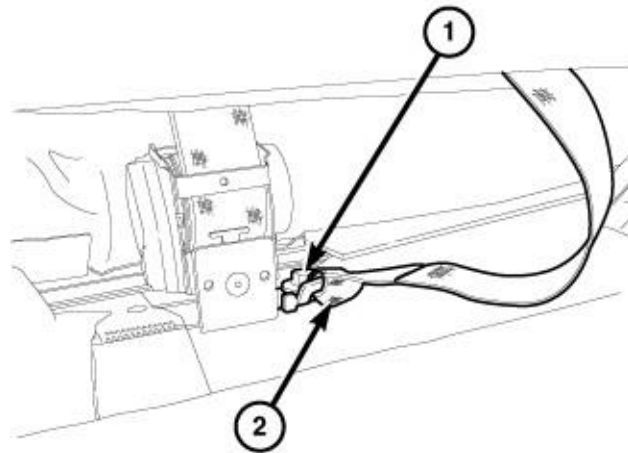

Figure 18 – Seat Electrical Connectors

Service Procedure [Continued]

- 10. Remove the bolt (1) attaching the center shoulder belt (2) to the retractor and position the shoulder belt out of the way (Figure 19).



2246727

Figure 19 – Center Shoulder Belt

- 11. Remove the rear outer bolts (1)

- 12. Remove the rear inner bolts (4) and buckles (3) as necessary (Figure 20).

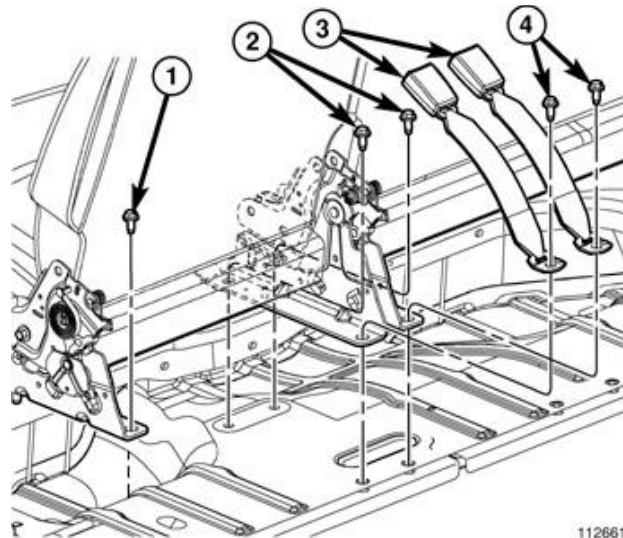

1126614

Figure 20 – Rear Seat Fasteners

Service Procedure [Continued]

13. Remove all the rear seat front bolts (1) (Figure 21).

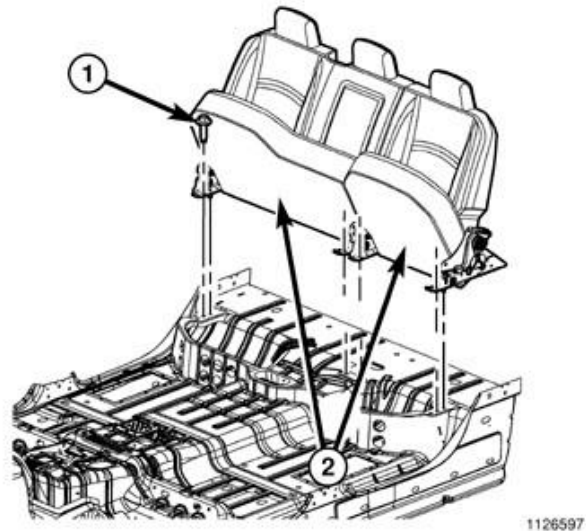

Figure 21 – Rear Seat Front Fasteners

14. Lift the rear seat assemblies up and separate the seat hooks (3) from the brackets (1 and 2) (Figure 22).

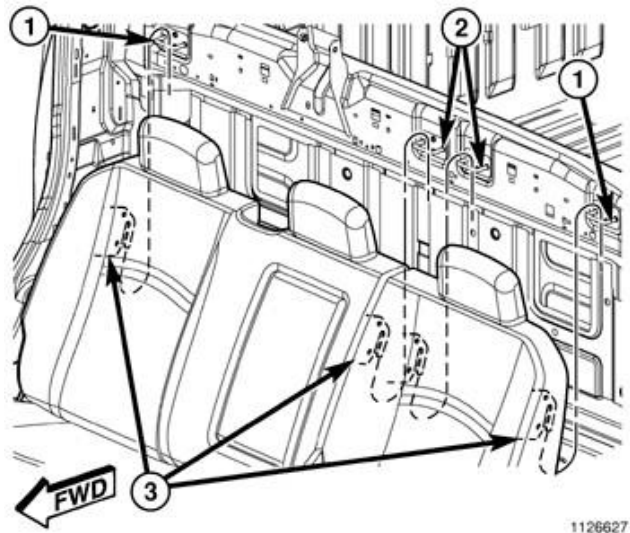

Figure 22 – Center Shoulder Belt

15. Remove the rear seat assembly from the vehicle.

Service Procedure [Continued]

16. Release the front and rear door sill scuff plates on either side of the B-pillar lower trim panel to allow for removal of the B-pillar lower trim panel (Figure 23).



Front Door Sill



Rear Door Sill

Figure 23 – Door Sill Scuff Plates

17. Release the retaining clips and remove the B-pillar lower trim panel to allow for removal of the B-pillar upper trim panel (Figure 24).

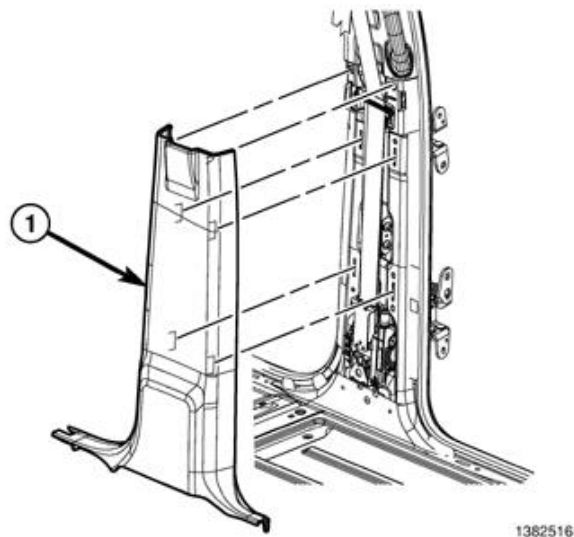

1382516

Figure 24 – B-Pillar Lower Trim Panel

Service Procedure [Continued]

18. On the B-pillar, separate the seatbelt turning loop cover then remove the turning loop bolt (Figure 25).

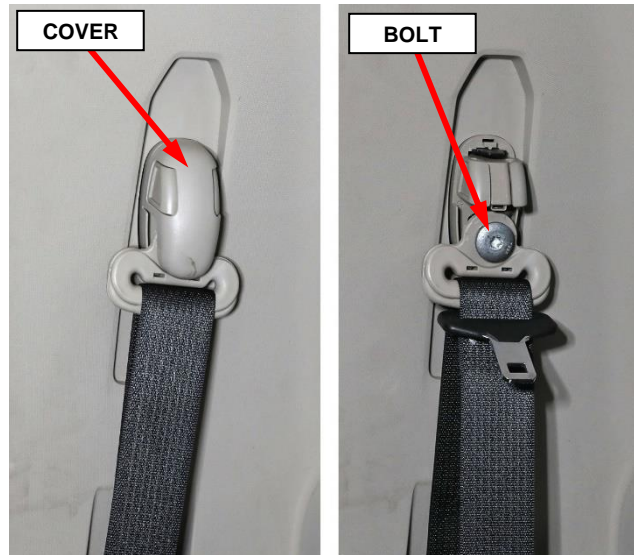

Figure 25 – Seat Belt Turning Loop

19. On the B-pillar, use a small flat-bladed tool to carefully open the two fastener covers (2) located on the grab handle (Figure 26).

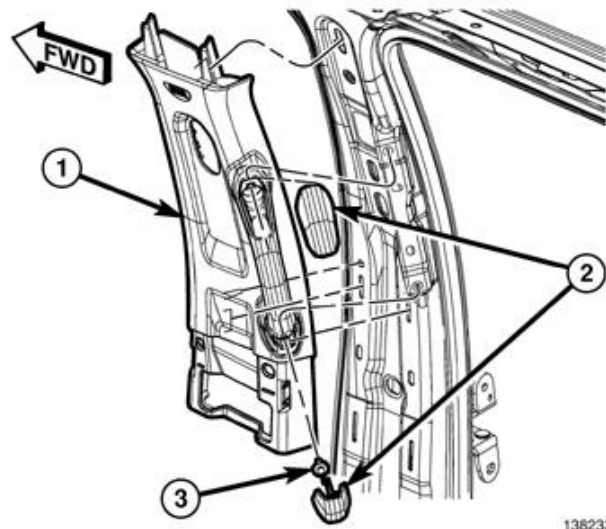

Figure 26 – B-Pillar Upper Trim Panel

20. Remove the two bolts (3) that secure the grab handle to the B-pillar (Figure 26).

21. Using a trim stick C-4755 or equivalent, release the retaining clips that secure the B-pillar upper trim panel (1) then position the trim panel out of the way. It is not necessary to remove the seat belt from the trim panel (Figure 26).

Service Procedure [Continued]

22. Release the upper retaining clips of the C-pillar lower trim panel to allow for removal of the C-pillar upper trim panel (Figure 27).



Figure 27 – C-Pillar Lower Trim Panel

23. On the C-pillar, lift the seat belt turning loop cover then remove the turning loop bolt (Figure 28).

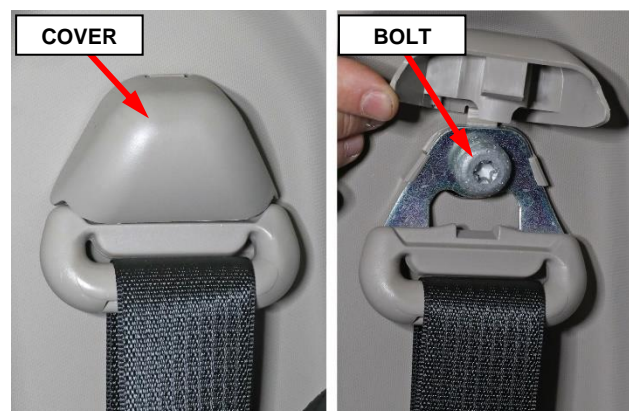

Figure 28 – Seat Belt Turning Loop

Service Procedure [Continued]

24. Using a trim stick or equivalent, release the C-pillar airbag applique then remove the screw that secures the upper trim panel (Figure 29).



Figure 29 – C-Pillar Upper Trim Panel

25. Release the retaining clips and remove the C-pillar upper trim panel (1) (Figure 30).

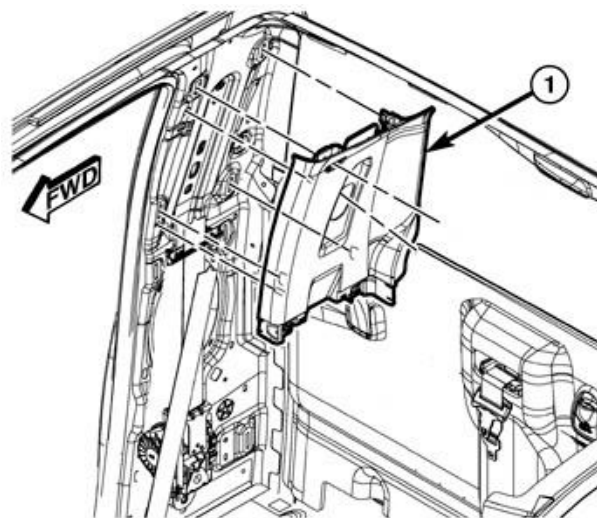

Figure 30 – C-Pillar Upper Trim Panel

Service Procedure [Continued]

CAUTION: Hands should be clean or clean cloth gloves used when handling the visors and headliner to avoid marks or damage.

26. If equipped with DVD monitor, remove the screws (2) and separate the monitor (1) from the roof (Figure 31).

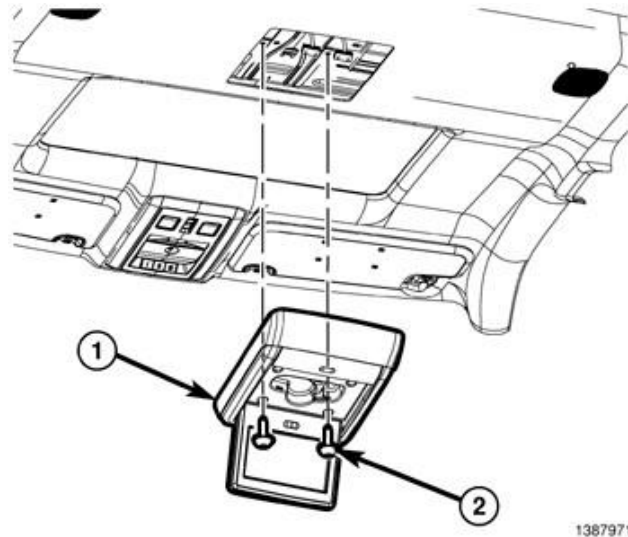

Figure 31 – Rear Seat DVD Monitor

27. If equipped with DVD monitor, disconnect the electrical connectors (1) (Figure 32).

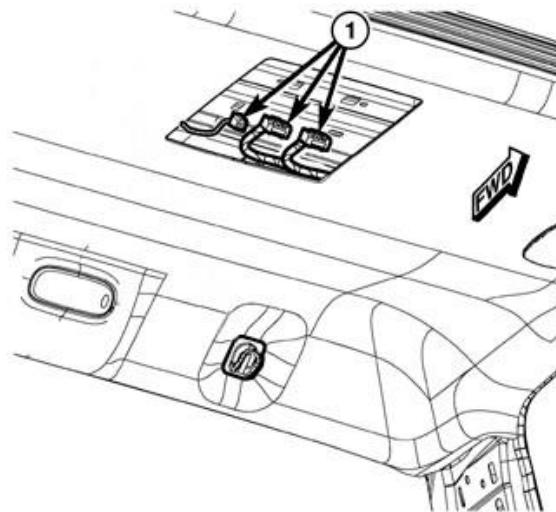

Figure 32 – DVD Monitor Electrical Connectors

Service Procedure [Continued]

28. Separate the visor from the support (1) then remove the screw and remove the visor support (Figure 33).

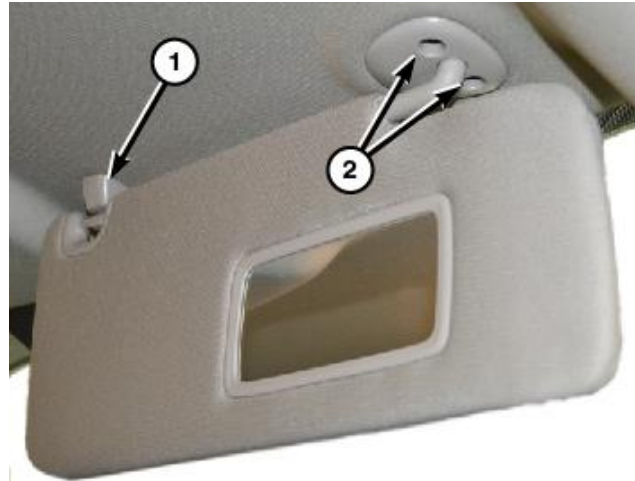

Figure 33 – Visors

29. Remove the visor screws (2) then remove the visor (Figure 33).

Using a small flat bladed tool or equivalent, release the retaining tabs (1) and separate the visor from the headliner (Figure 34).



Figure 34 – Visors

30. Disconnect the visor electrical connector if equipped.

NOTE: In some cases, the wire harness for the visor vanity mirror may be glued to the top side of the headliner and may be a little difficult to release.

31. Using a small flat bladed tool, open the coat hook screw cover (2) then remove the screw and coat hook (Figure 35).

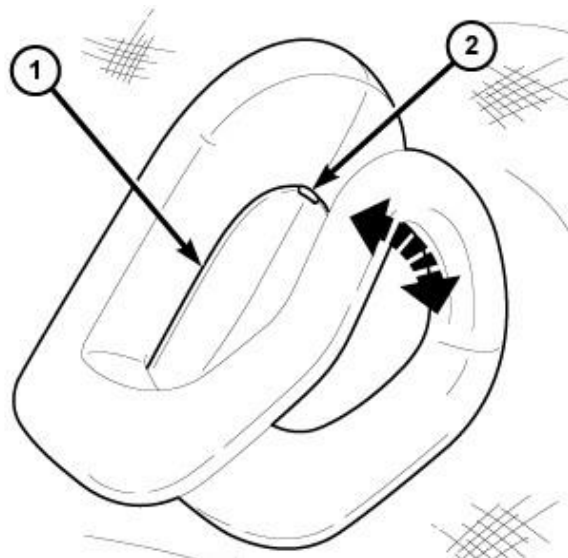

Figure 35 – Coat Hook

Service Procedure [Continued]

32. As necessary, release the headliner wiring harness clips (3) from the A-pillar to allow enough wiring harness slack for lowering the headliner (Figure 36).

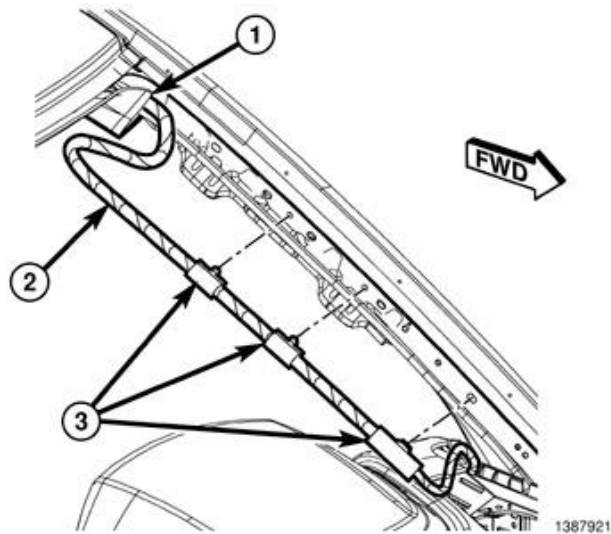

Figure 36 – Headliner Harness

33. Release the door seals from the door openings in order to allow for lowering of the headliner.

34. Carefully lower the headliner (2) allowing it to rest on the seat backs and instrument panel (Figure 37).

CAUTION: Disconnect any wiring harness electrical connectors (1) as necessary to allow enough wiring harness slack while lowering headliner. It will not be necessary to remove the headliner from the vehicle (Figure 37).

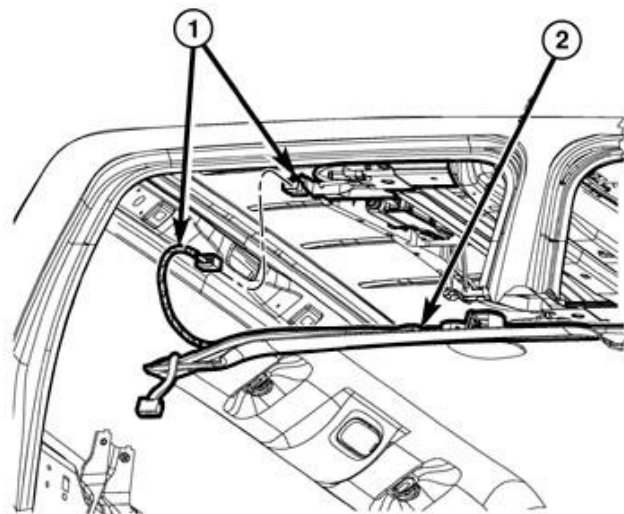
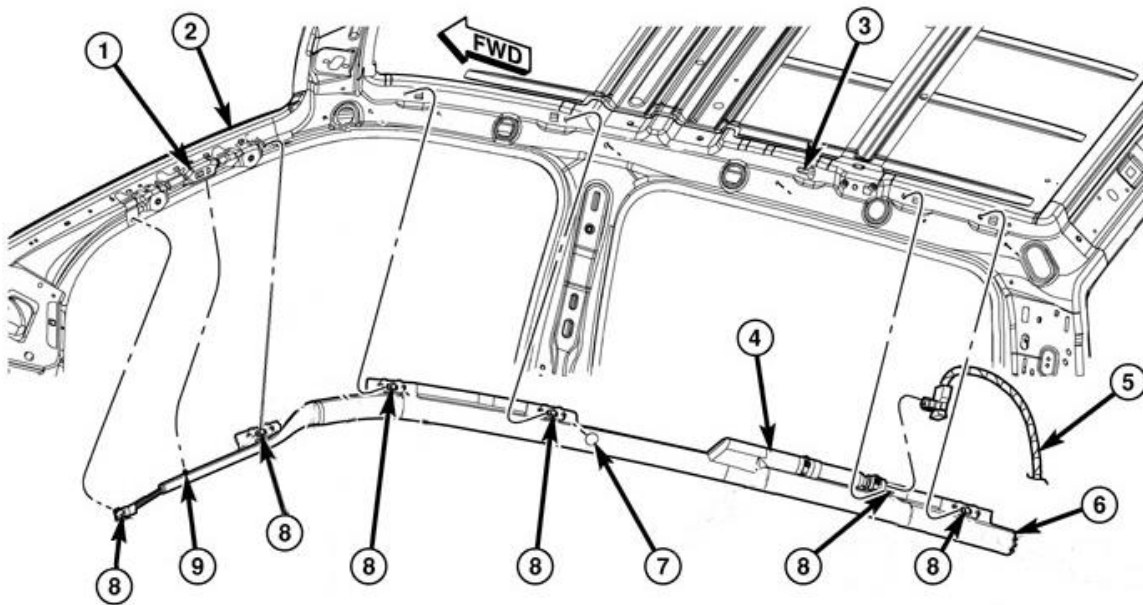

Figure 37 – Headliner Harness

35. Obtain the appropriate replacement SABIC(s) for the vehicle based on its VIN.

Service Procedure [Continued]

36. The body wire harness connector (5) is secured by integral latches to the connector receptacle on the inflator (4). Pinch both latches firmly, then pull the connector straight out from the airbag inflator to disconnect it from the connector receptacle (Figure 38).
37. Remove the six bolts (8) that secure the side curtain airbag (6) to the inner roof rail and A-pillar (Figure 38).
38. Disengage the plastic push-in retainer (9) that secures the side curtain airbag tether to the inner A-pillar (1) and the plastic push-in retainer (7) that secures the side curtain airbag to the inner roof rail (Figure 38).
39. Slide the inflator rearward far enough to disengage the T-tab at the front of the inflator bracket from the keyed T-slot in the inner roof rail over the rear door opening (Figure 39).
40. Remove the SABIC (6) from the vehicle as a unit and **DISCARD** following local ordinances and recommended procedures for handling and disposal of Non-Deployed Supplemental Restraints (Figure 39). Provided packaging is not authorized for the transport of the recalled SABIC Module. Parts will need to be either deployed on-site or transported in alternative approved containers.

**Figure 38 – SABIC**

Service Procedure [Continued]

Figure 39 – SABIC Inflator T-Tab and Inner Roof Rail T-Slot

41. Check to be certain that the spring nuts are properly installed in the inner roof rail and that they are in good condition.
42. Position the **NEW SABIC** (6) into the vehicle as a unit (Figure 38).
43. Insert the T-tab at the front of the inflator bracket into the keyed T-slot in the inner roof rail over the rear door opening and slide the inflator forward to engage it (Figure 39).
44. Engage the plastic push-in retainer (7) that secures the side curtain airbag to the inner roof rail and ensure the tether is not twisted then engage the plastic push-in retainer (9) that secures the side curtain airbag front tether to the assist handle bracket on the inner A-pillar (1) (Figure 38).
45. Working from rear to front, install and tighten the seven bolts (8) that secure the side curtain airbag (6) to the inner roof rail and A-pillar. Tighten the bolts to 7 N·m (62 in. lbs.) (Figure 38).
46. Connect the body wire harness connector (5) for the side curtain airbag to the connector receptacle of the inflator (4). Be certain that each connector is fully engaged in its receptacle by listening carefully for a distinct, audible click as the connector latches snap into place (Figure 38).

Service Procedure [Continued]

CAUTION: Hands should be clean or clean cloth gloves used when handling the headliner to avoid damage to the headliner.

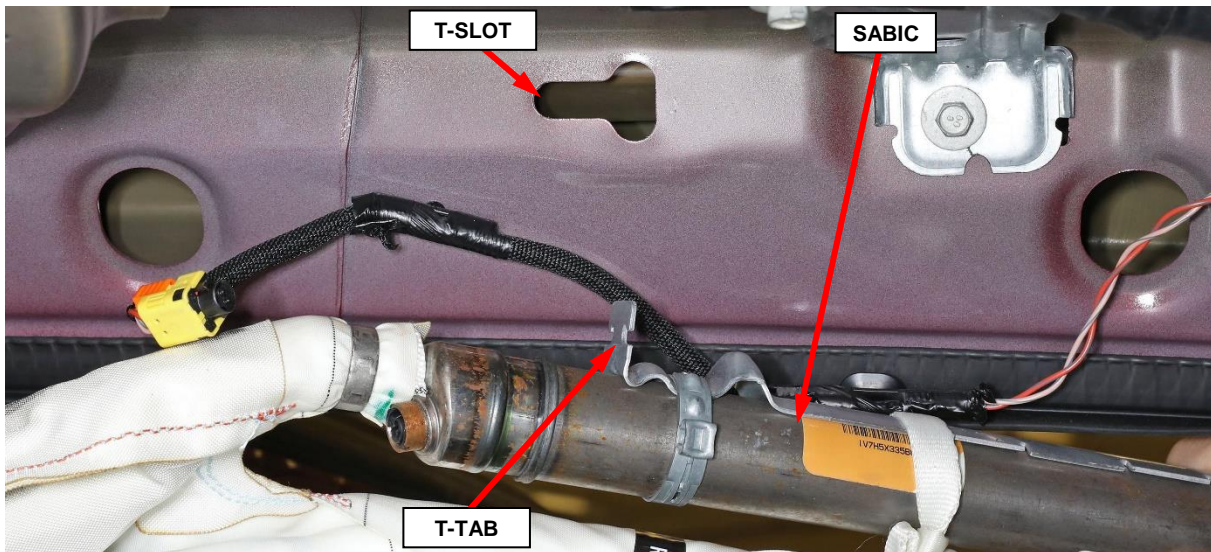
47. Raise the headliner into proper vehicle position and connect any electrical connectors previously disconnected from the headliner (Figure 37).

CAUTION: Be certain to avoid any wiring or drain tube interference.

48. Position the coat hooks (5) onto the headliner and install the screws tightening securely into the mounting clips then close the screw cap fully (Figure 35).
49. Position the visor supports (1) onto the headliner and install the screws into the mounting clips (Figure 33).
50. If equipped with illuminated vanity mirror, connect the wire harness connector.
51. Position the visor to the headliner and install the screws (2) that secure the visor to the roof panel. Tighten the screws to 6 N·m (53 in. lbs.) (Figure 33).
52. Reattach any headliner wiring harness clips (3) removed from the A-pillar to allow slack while lowering headliner (Figure 36).
53. If equipped with DVD monitor, connect the DVD monitor electrical connectors (1) (Figure 32). Position the DVD monitor to the roof then install and tighten the screws (2) (Figure 31).

Service Procedure [Continued]

54. Position the upper trim (1) to the C-pillar then engage the retaining clips (Figure 30).
55. Install and tighten the screw that secures the C-pillar upper trim panel. Then install the airbag applique (Figure 29).
56. Remove and **DISCARD** the bolt retainer and bolt from the seat belt turning loop, save the spacer washer for reuse (Figure 40).

57. Using a **NEW** bolt and reusing the spacer, install the turning loop then tighten the bolt to 40 N·m (30 ft. lbs.) (Figure 28).

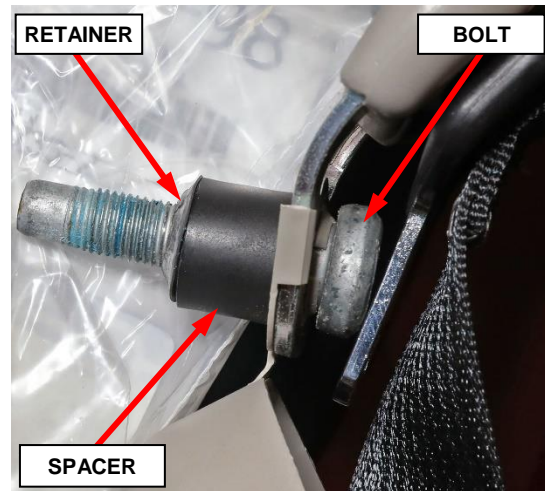
**Figure 40 – Turning Loop Bolt**

58. Install the seat belt turning loop cover (Figure 28).
59. Position the C-pillar lower trim panel and engage the retaining clips (Figure 27).

NOTE: Ensure that all C-pillar fasteners are installed/engaged properly.

60. Install the B-pillar upper trim panel (1) and engage the retaining clips fully (Figure 26).
61. Install the grab handle bolts (3) and tighten to 5 N·m (44 in. lbs.). Close the fastener covers (2) (Figure 26).

Service Procedure [Continued]

62. Remove and **DISCARD** the bolt retainer and bolt from the seat belt turning loop, save the spacer washer for reuse (Figure 41).

63. Using a **NEW** bolt and reusing the spacer washer, install the turning loop then tighten the bolt to 40 N·m (30 ft. lbs.) (Figure 24).

64. Install the seat belt turning loop cover (Figure 25).

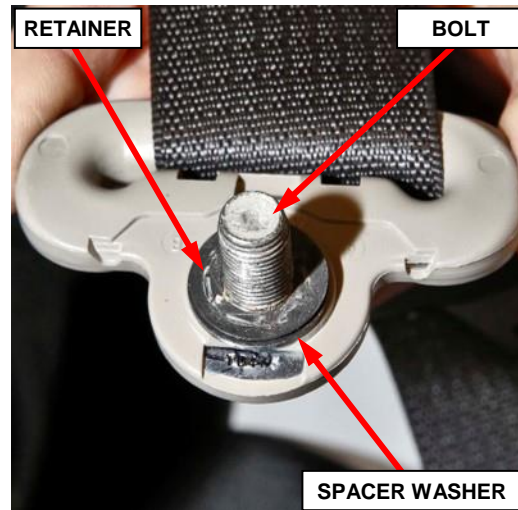

Figure 41 – Turning Loop Bolt

65. Position the B-pillar lower trim panel and engage the retaining clips fully (Figure 24).

66. Position the front and rear door sill scuff plates and engage the retainers (Figure 23).

67. Position the rear seat assembly into the vehicle and lift the seat hooks (3) onto the brackets (1 and 2) (Figure 22).

68. Install the rear seat front bolts (1) (Figure 21).

69. Loosely install the rear seat belts (3) and bolts (4) (Figure 20).

70. Install the remaining rear seat bolts (1) then tighten all bolts to 47 N·m (35 ft. lbs.) (Figure 20).

Service Procedure [Continued]

71. Position the rear center shoulder belt (2) into place and install the bolt (1). Tighten the bolt to 23 N·m (17 ft. lbs.) (Figure 19).
72. If equipped, connect the rear seat electrical connectors (1) (Figure 18).
73. If equipped with subwoofer, position the subwoofer (2) to vehicle. Connect the electrical connector. Install and tighten the mounting fasteners (1) then lower the rear seat (Figure 17).

WARNING: Do not connect the negative battery cable at this time. The Supplemental Restraint System (SRS) Verification Test procedure should be performed following service of any SRS component.

NOTE: The following procedure should be performed using a diagnostic scan tool to verify proper Supplemental Restraint System (SRS) operation following the service or replacement of any SRS component. Refer to the appropriate diagnostic procedures.

74. During the following test, the negative cable remains disconnected and isolated from the battery, as it was during the Supplemental Restraint System (SRS) component removal and installation procedures.
75. Be certain that the diagnostic scan tool contains the latest version of the proper diagnostic software. Connect the scan tool to the 16-way Data Link Connector (DLC). The DLC is located on the driver side lower edge of the instrument panel, near the steering column opening cover and outboard of the steering column.
76. Transition the status of the ignition switch (also known as the Keyless Ignition Node/KIN or IGnition Node Module/IGNM) to ON and exit the vehicle with the scan tool.

Service Procedure [Continued]

77. Check to be certain that nobody is in the vehicle, then connect the negative cable to the battery.
78. Using the scan tool, read and record the active (current) Diagnostic Trouble Code (DTC) data.
79. Next, use the scan tool to read and record any stored (historical) DTC data.
80. If any SRS related DTC is found in the previous two steps, refer to the appropriate diagnostic information.
81. Use the scan tool to erase the stored DTC data. If any problems remain, the stored DTC data will not erase. Refer to the appropriate diagnostic information to diagnose any stored DTC that will not erase. If the stored DTC information is successfully erased, continue to the next step.
82. Transition the status of the ignition switch to OFF for about 15 seconds, and then back to ON. Observe the airbag indicator in the instrument cluster. It should light from four to six seconds, and then go out. This indicates that the SRS is functioning normally and that the repairs are complete. If the airbag indicator fails to light, or lights and stays ON, there is still an active SRS fault or malfunction. Refer to the appropriate diagnostic information to diagnose the problem.
83. Install the front seat headrests (Figure 16).
84. Position the locating tab of the A-pillar trim panel (2) into the slot located in the top of the instrument panel (Figure 15).
85. Install the A-pillar trim panel onto the A-pillar (1) and install the two bolts (4). Tighten the bolts to 5 N·m (44 in. lbs.) (Figure 15).
86. Close the two fastener covers (3) located in the A-pillar trim panel (Figure 15).
87. Install the door seals around the door openings.
88. Return the vehicle to the customer or inventory.

Service Procedure [Continued]**C. Crew Cab**

1. Using a small flat-bladed tool, carefully open the two fastener covers (3) located in the A-pillar trim panel (2) (Figure 42).
2. Remove the two bolts (4) that secure the A-pillar trim panel to the A-pillar (1) and remove the trim panel (Figure 42).

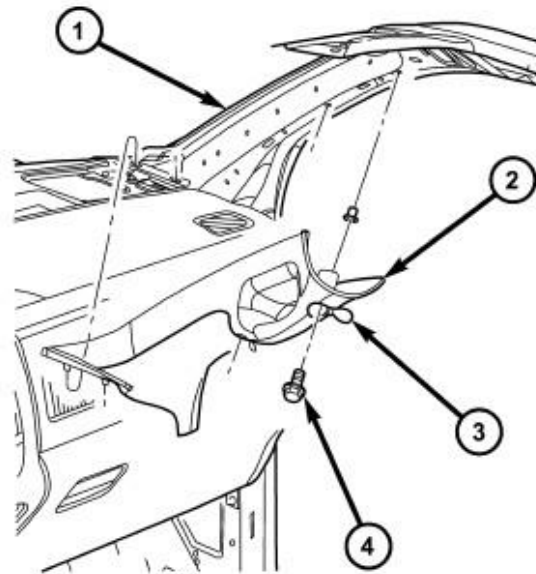

80d407a9

Figure 42 – A-Pillar

3. Push in the buttons on front seat headrest sleeves then pull the headrest up and remove (Figure 43).

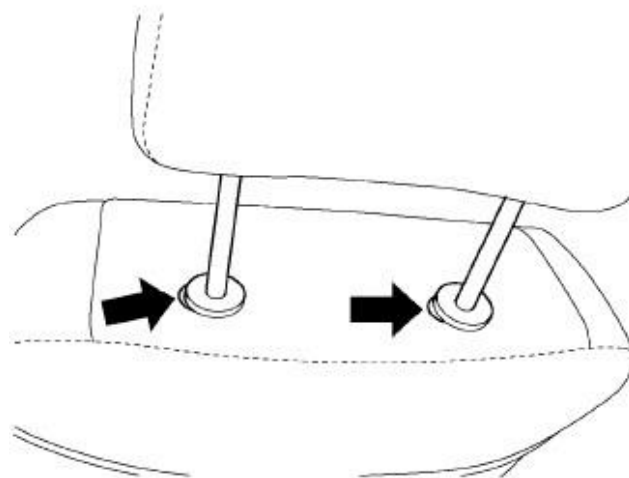

8120dd43

4. Position the front seats to the full forward position with the seat backs fully forward.

Figure 43 – Head Rest

Service Procedure [Continued]

5. Disconnect and isolate the negative battery cable. If equipped with an Intelligent Battery Sensor (IBS), disconnect the IBS connector first before disconnecting the negative battery cable. Wait two minutes for the system capacitor to discharge before further service.

WARNING: To avoid serious or fatal injury on vehicles equipped with airbags, disable the Supplemental Restraint System (SRS) before attempting any steering wheel, steering column, airbag, seat belt tensioner, impact sensor or instrument panel component diagnosis or service. Disconnect and isolate the battery negative (ground) cable, then wait two minutes for the system capacitor to discharge before performing further diagnosis or service. This is the only sure way to disable the SRS. Failure to take the proper precautions could result in accidental airbag deployment.

WARNING: To avoid serious or fatal injury when removing a deployed airbag, rubber gloves, eye protection, and a long-sleeved shirt should be worn. There may be deposits on the airbag unit and other interior surfaces. In large doses, these deposits may cause irritation to the skin and eyes.

WARNING: To avoid serious or fatal injury, use extreme care to prevent any foreign material from entering the side curtain airbag, or becoming entrapped between the side curtain airbag cushion and the headliner. Failure to observe this warning could result in occupant injuries upon airbag deployment.

NOTE: The following procedure is for replacement of an ineffective or damaged side curtain airbag (also known as Side Air Bag Inflatable Curtain/SABIC). If the airbag is ineffective or damaged, but not deployed, review local ordinances regarding recommended procedures for handling and disposal of Non-Deployed Supplemental Restraints.

NOTE: If a side curtain airbag is being removed, but has not been deployed, the headliner does not need to be removed from the passenger compartment. Lowering the headliner and resting it on the seat backs will allow enough clearance to remove the side curtain airbag from the vehicle.

Service Procedure [Continued]

6. If equipped with a subwoofer speaker, raise the right rear seat to access the subwoofer (2) (Figure 44).

7. Remove the subwoofer mounting fasteners (1) (Figure 44).

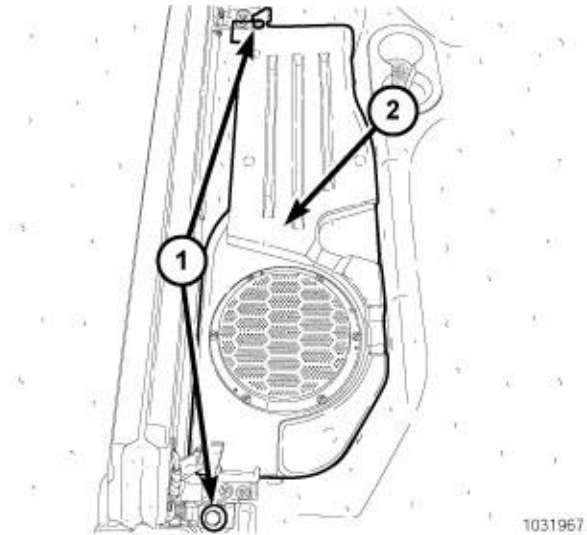

Figure 44 – Subwoofer

8. Disconnect the electrical connector and remove the subwoofer (2) (Figure 44).

NOTE: 60/40 bench seat shown, solid bench seat similar.

9. If equipped, disconnect the electrical connectors (1) under the rear seat (Figure 45).

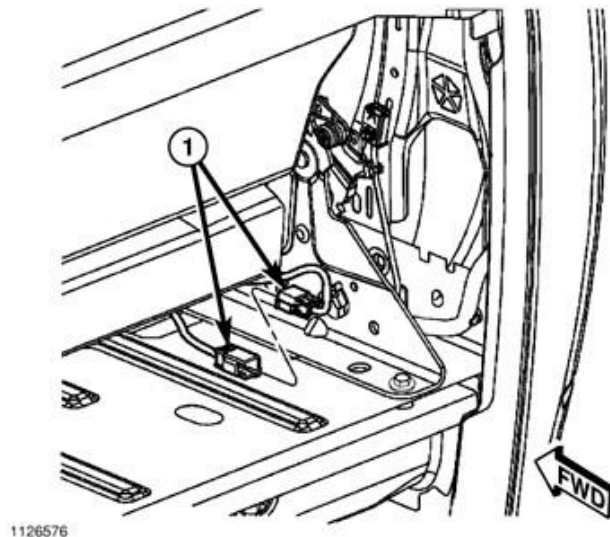
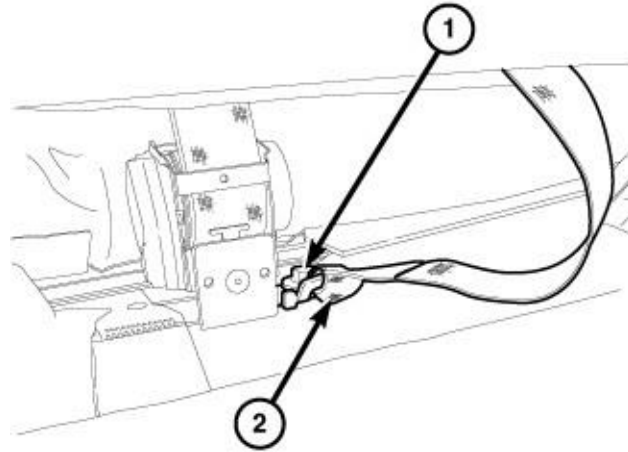

Figure 45 – Seat Electrical Connectors

Service Procedure [Continued]

- 10. Remove the bolt (1) attaching the center shoulder belt (2) to the retractor and position the shoulder belt out of the way (Figure 46).



2246727

Figure 46 – Center Shoulder Belt

- 11. Remove the rear outer bolts (1) (Figure 47).
- 12. Remove the rear inner bolts (4) and buckles (3) as necessary (Figure 47).

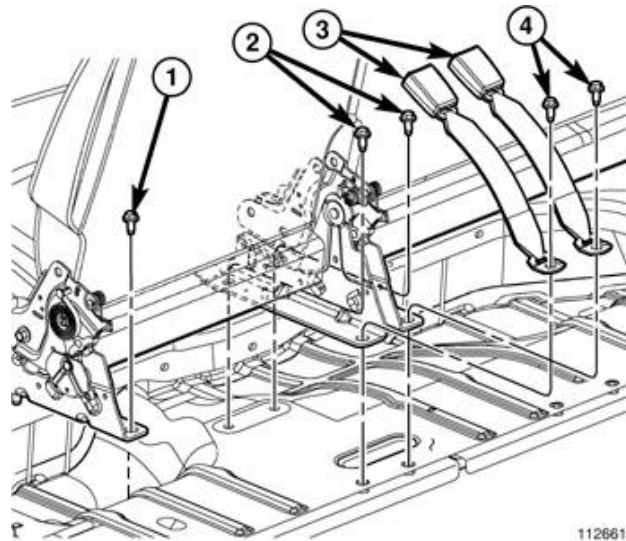

1126614

Figure 47 – Rear Seat Fasteners

Service Procedure [Continued]

- Remove all the rear seat front bolts (1) (Figure 48).

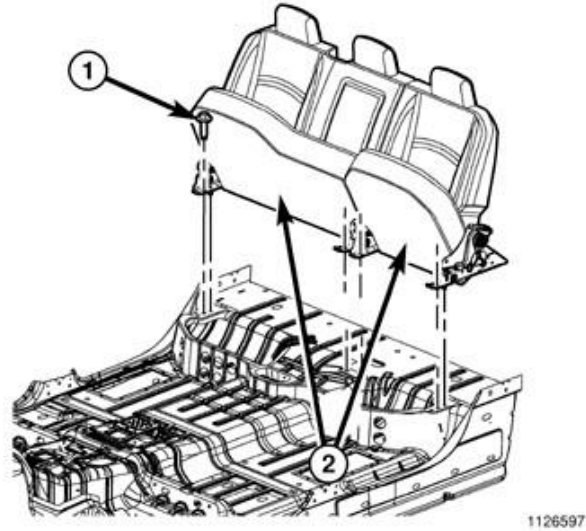

Figure 48 – Rear Seat Front Fasteners

- Lift the rear seat assemblies up and separate the seat hooks (3) from the brackets (1 and 2) (Figure 49).

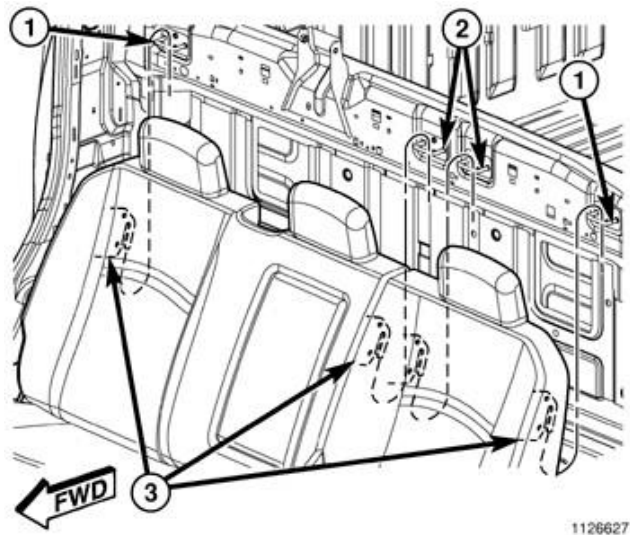

Figure 49 – Center Shoulder Belt

- Remove the rear seat assembly from the vehicle.

Service Procedure [Continued]

16. Release the front and rear door sill scuff plates on either side of the B-pillar lower trim panel to allow for removal of the B-pillar lower trim panel (Figure 50).



Front Door Sill



Rear Door Sill

Figure 50 – Door Sill Scuff Plates

17. Release the retaining clips and remove the B-pillar lower trim panel to allow for removal of the B-pillar upper trim panel (Figure 51).

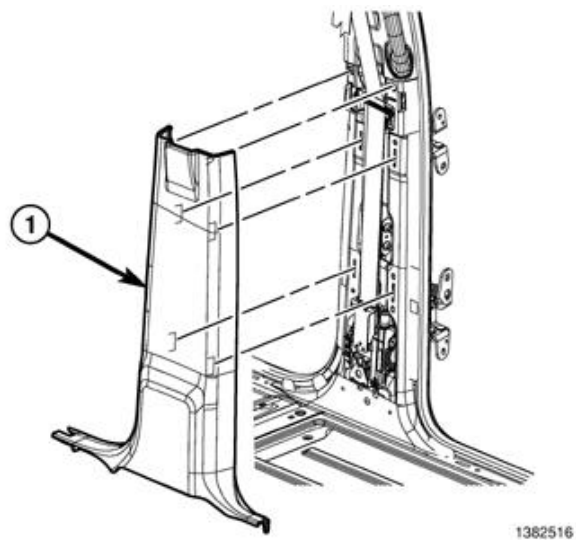

Figure 51 – B-Pillar Lower Trim Panel

Service Procedure [Continued]

18. On the B-pillar, separate the seatbelt turning loop cover then remove the turning loop bolt (Figure 52).

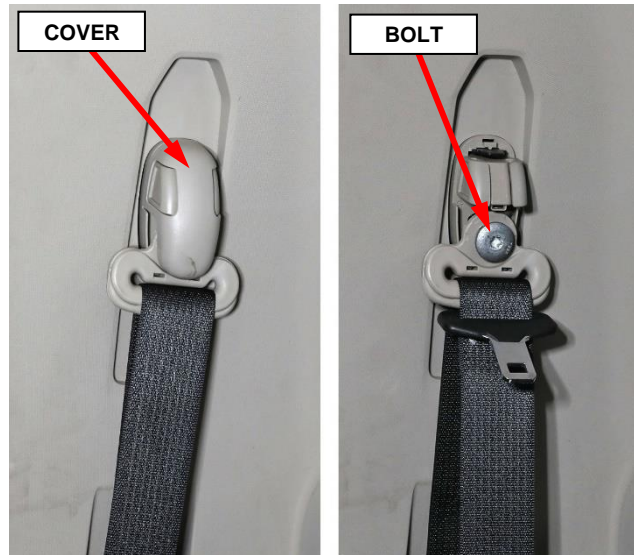

Figure 52 – Seat Belt Turning Loop

19. On the B-pillar, use a small flat-bladed tool to carefully open the two fastener covers (2) located on the grab handle (Figure 52).

20. Remove the two bolts (3) that secure the grab handle to the B-pillar (Figure 53).

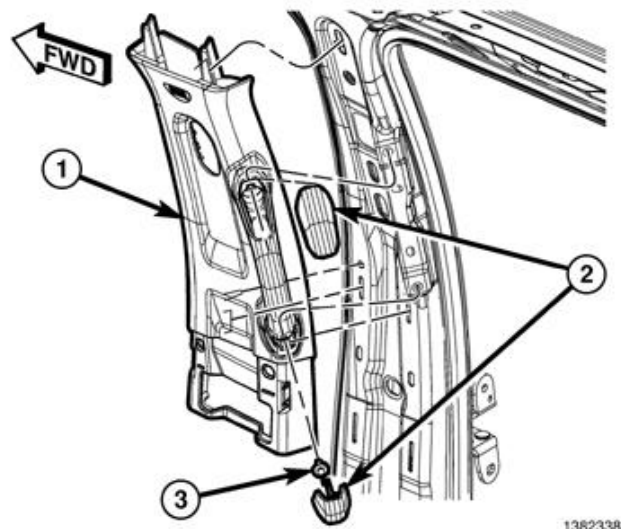

Figure 53 – B-Pillar Upper Trim Panel

21. Using a trim stick C-4755 or equivalent, release the retaining clips that secure the B-pillar upper trim panel (1) then position the trim panel out of the way. It is not necessary to remove the seat belt from the trim panel (Figure 53).

Service Procedure [Continued]

22. Using a trim stick or equivalent, release the C-pillar airbag applique then remove the screw that secures the upper trim panel (Figure 54).

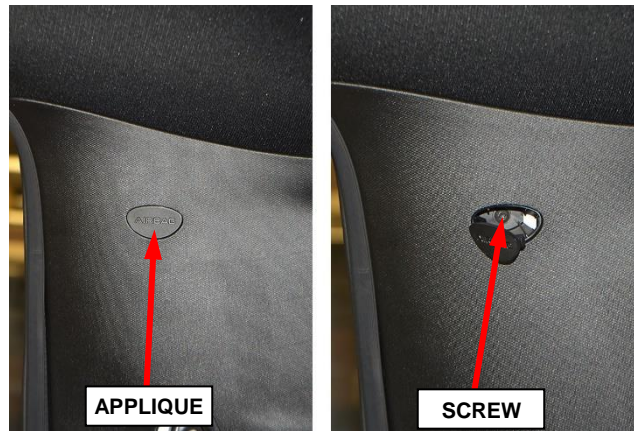

Figure 54 – C-Pillar Upper Trim Panel

23. Release the upper retaining clips then tilt the upper portion of the C-pillar lower trim panel away from the C-pillar (Figure 54).

24. Release the retaining clips then remove the upper trim panel from the C-pillar (Figure 55).



Figure 55 – C-Pillar Trim Panels

Service Procedure [Continued]

25. If equipped with DVD monitor, remove the screws (2) and separate the monitor (1) from the roof (Figure 56).

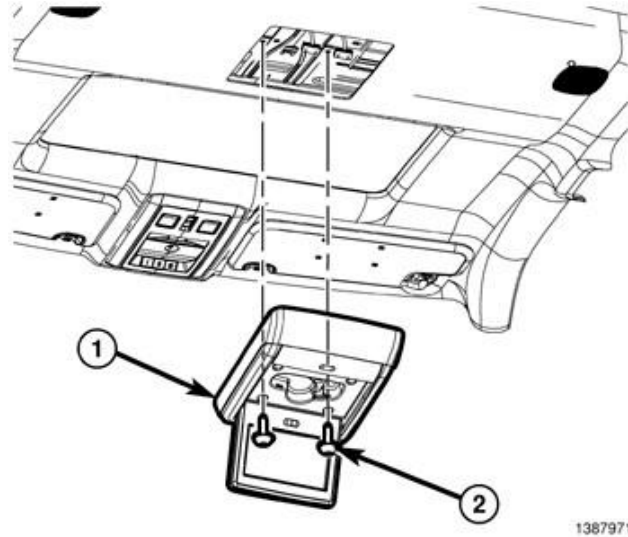

Figure 56 – Rear Seat DVD Monitor

26. If equipped with DVD monitor, disconnect the electrical connectors (1) (Figure 57).

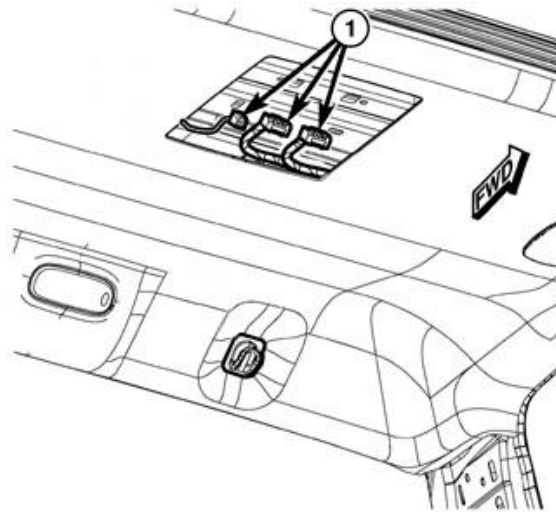

Figure 57 – DVD Monitor Electrical Connectors

Service Procedure [Continued]

27. Separate the visor from the support (1) then remove the screw and remove the visor support (Figure 58).

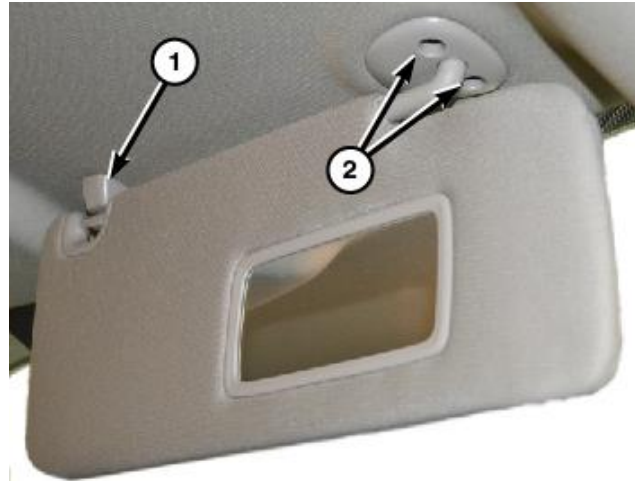

Figure 58 – Visors

28. Remove the visor screws (2) then remove the visor (Figure 58).

Using a small flat bladed tool or equivalent, release the retaining tabs (1) and separate the visor from the headliner (Figure 59).

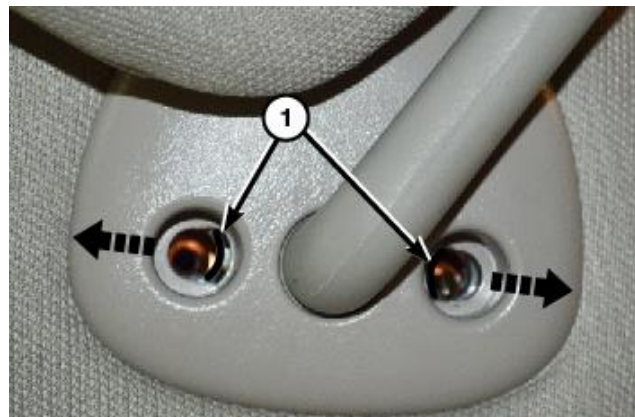

Figure 59 – Visors

29. Disconnect the visor electrical connector if equipped.

NOTE: In some cases, the wire harness for the visor vanity mirror may be glued to the top side of the headliner and may be a little difficult to release.

30. Using a small flat bladed tool, open the coat hook screw cover (2) then remove the screw and coat hook (Figure 60).

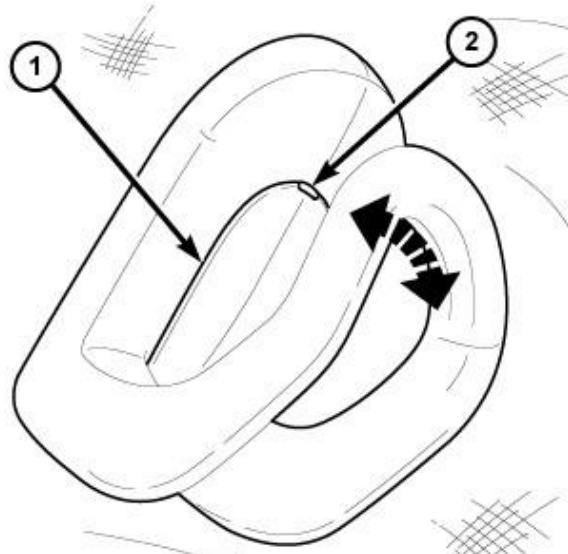

Figure 60 – Coat Hook

Service Procedure [Continued]

31. As necessary, release the headliner wiring harness clips (3) from the A-pillar to allow enough wiring harness slack for lowering the headliner (Figure 61).

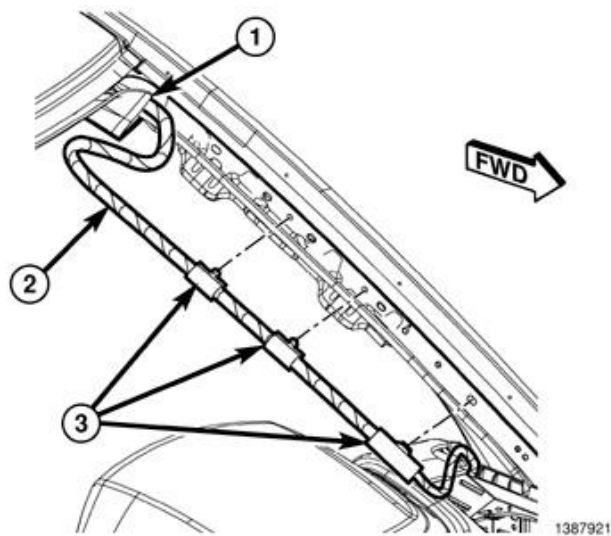

Figure 61 – Headliner Harness

32. Release the door seals from the door openings in order to allow for lowering of the headliner.

33. Carefully lower the headliner (2) allowing it to rest on the seat backs and instrument panel (Figure 62).

CAUTION: Disconnect any wiring harness electrical connectors (1) as necessary to allow enough wiring harness slack while lowering headliner. It will not be necessary to remove the headliner from the vehicle (Figure 62).

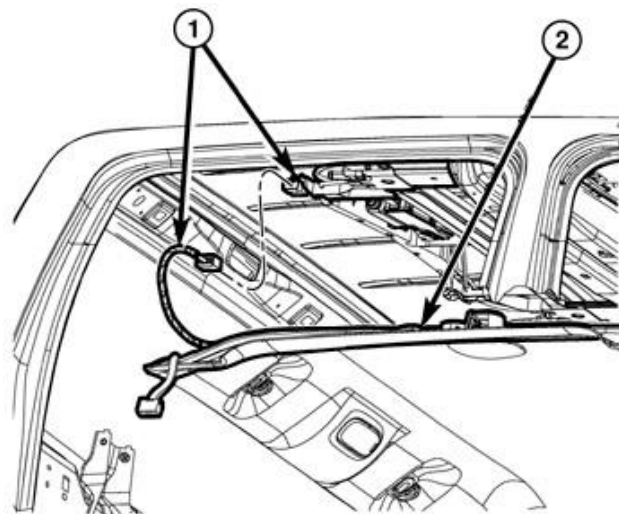
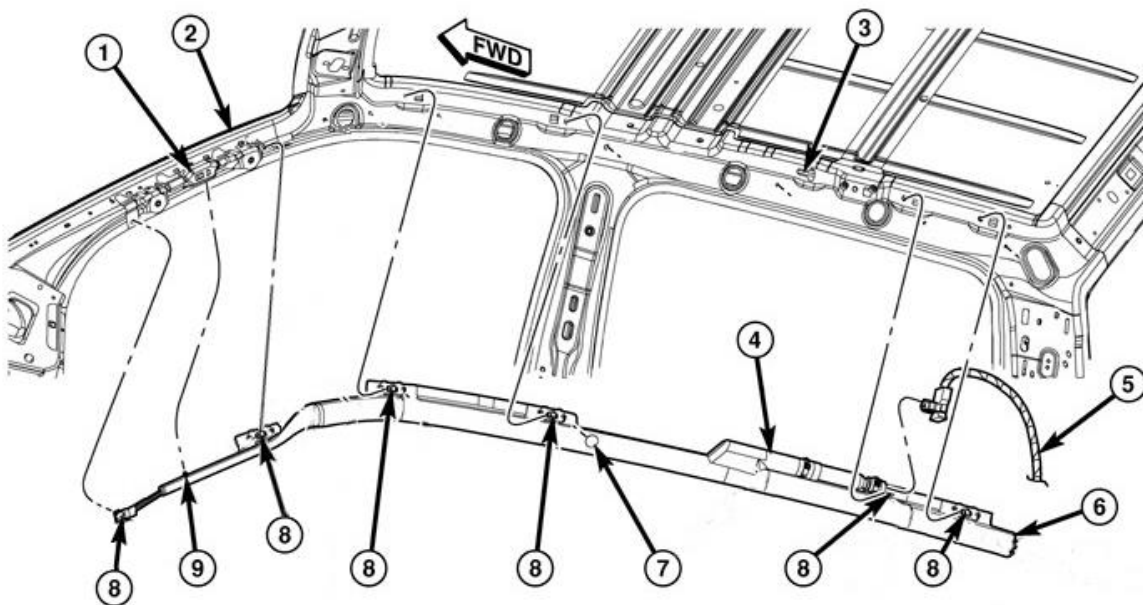

Figure 62 – Headliner Harness

34. Obtain the appropriate replacement SABIC(s) for the vehicle based on its VIN.

Service Procedure [Continued]

35. The body wire harness connector (5) is secured by integral latches to the connector receptacle on the inflator (4). Pinch both latches firmly, then pull the connector straight out from the airbag inflator to disconnect it from the connector receptacle (Figure 63).
36. Remove the six bolts (8) that secure the side curtain airbag (6) to the inner roof rail and A-pillar (Figure 63).
37. Disengage the plastic push-in retainer (9) that secures the side curtain airbag tether to the inner A-pillar (1) and the plastic push-in retainer (7) that secures the side curtain airbag to the inner roof rail (Figure 63).
38. Slide the inflator rearward far enough to disengage the T-tab at the front of the inflator bracket from the keyed T-slot in the inner roof rail over the rear door opening (Figure 64).
39. Remove the SABIC (6) from the vehicle as a unit and **DISCARD** following local ordinances and recommended procedures for handling and disposal of Non-Deployed Supplemental Restraints (Figure 63). Provided packaging is not authorized for the transport of the recalled SABIC Module. Parts will need to be either deployed on-site or transported in alternative approved containers.

**Figure 63 – SABIC**

Service Procedure [Continued]

Figure 64 – SABIC Inflator T-Tab and Inner Roof Rail T-Slot

40. Check to be certain that the spring nuts are properly installed in the inner roof rail and that they are in good condition.
41. Position the **NEW SABIC** (6) into the vehicle as a unit (Figure 63).
42. Insert the T-tab at the front of the inflator bracket into the keyed T-slot in the inner roof rail over the rear door opening and slide the inflator forward to engage it (Figure 64).
43. Engage the plastic push-in retainer (7) that secures the side curtain airbag to the inner roof rail and ensure the tether is not twisted then engage the plastic push-in retainer (9) that secures the side curtain airbag front tether to the assist handle bracket on the inner A-pillar (1) (Figure 63).
44. Working from rear to front, install and tighten the seven bolts (8) that secure the side curtain airbag (6) to the inner roof rail and A-pillar. Tighten the bolts to 7 N·m (62 in. lbs.) (Figure 63).
45. Connect the body wire harness connector (5) for the side curtain airbag to the connector receptacle of the inflator (4). Be certain that each connector is fully engaged in its receptacle by listening carefully for a distinct, audible click as the connector latches snap into place (Figure 63).

Service Procedure [Continued]

CAUTION: Hands should be clean or clean cloth gloves used when handling the headliner to avoid damage to the headliner.

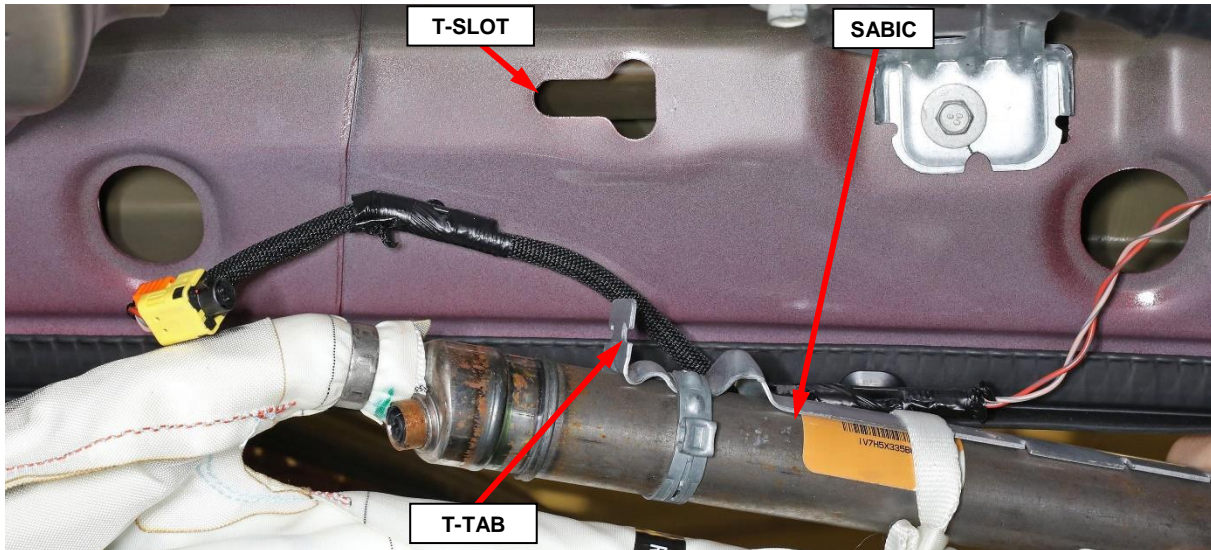
46. Raise the headliner into proper vehicle position and connect any electrical connectors previously disconnected from the headliner (Figure 62).

CAUTION: Be certain to avoid any wiring or drain tube interference.

47. Position the coat hooks (5) onto the headliner and install the screws tightening securely into the mounting clips then close the screw cap fully (Figure 60).
 48. Position the visor supports (1) onto the headliner and install the screws into the mounting clips (Figure 58).
 49. If equipped with illuminated vanity mirror, connect the wire harness connector.
 50. Position the visor to the headliner and install the screws (2) that secure the visor to the roof panel. Tighten the screws to 6 N·m (53 in. lbs.) (Figure 58).
 51. Reattach any headliner wiring harness clips (3) removed from the A-pillar to allow slack while lowering headliner (Figure 61).
 52. If equipped with DVD monitor, connect the DVD monitor electrical connectors (1) (Figure 57). Position the DVD monitor to the roof then install and tighten the screws (2) (Figure 56).
 53. Position the upper trim panel to the C-pillar then engage the retaining clips (Figure 55).
 54. Position the C-pillar lower trim panel and engage the retaining clips (Figure 55).
- NOTE: Ensure that all C-pillar fasteners are installed/engaged properly.**
55. Install and tighten the screw that secures the C-pillar upper trim panel. Then install the airbag applique (Figure 54).

Service Procedure [Continued]

56. Install the B-pillar upper trim panel (1) and engage the retaining clips fully (Figure 53).
57. Install the grab handle bolts (3) and tighten to 5 N·m (44 in. lbs.). Close the fastener covers (2) (Figure 53).
58. Remove and **DISCARD** the bolt retainer and the bolt from the seat belt turning loop, save the spacer washer for reuse (Figure 65).
59. Using a **NEW** bolt and reusing the spacer washer, install the turning loop then tighten the bolt to 40 N·m (30 ft. lbs.) (Figure 52).
60. Install the seat belt turning loop cover (Figure 52).
61. Position the B-pillar lower trim panel and engage the retaining clips fully (Figure 51).
62. Position the front and rear door sill scuff plates and engage the retainers (Figure 50).
63. Position the rear seat assembly into the vehicle. lift the seat hooks (3) onto the brackets (1 and 2) (Figure 49).
64. Install the rear seat front bolts (1) (Figure 48).
65. Loosely install the seat belts (3) and bolts (4) (Figure 47).
66. Install the remaining bolts (1) then tighten all bolts to 47 N·m (35 ft. lbs.) (Figure 47).

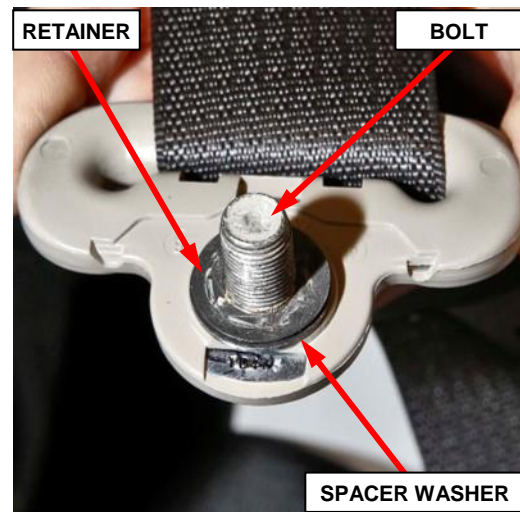
**Figure 65 – Turning Loop Bolt**

Service Procedure [Continued]

67. Position the shoulder belt (2) into place and install the bolt (1). Tighten the bolt to 23 N·m (17 ft. lbs.) (Figure 46).
68. If equipped, connect the rear seat electrical connectors (1) (Figure 45).
69. If equipped with subwoofer, position the subwoofer (2) to vehicle. Connect the electrical connector. Install and tighten the mounting fasteners (1) then lower the seat (Figure 44).

WARNING: Do not connect the negative battery cable at this time. The Supplemental Restraint System (SRS) Verification Test procedure should be performed following service of any SRS component.

NOTE: The following procedure should be performed using a diagnostic scan tool to verify proper Supplemental Restraint System (SRS) operation following the service or replacement of any SRS component. Refer to the appropriate diagnostic procedures.

70. During the following test, the negative cable remains disconnected and isolated from the battery, as it was during the Supplemental Restraint System (SRS) component removal and installation procedures.
71. Be certain that the diagnostic scan tool contains the latest version of the proper diagnostic software. Connect the scan tool to the 16-way Data Link Connector (DLC). The DLC is located on the driver side lower edge of the instrument panel, near the steering column opening cover and outboard of the steering column.
72. Transition the status of the ignition switch (also known as the Keyless Ignition Node/KIN or Ignition Node Module/IGNM) to ON and exit the vehicle with the scan tool.
73. Check to be certain that nobody is in the vehicle, then connect the negative cable to the battery.

Service Procedure [Continued]

74. Using the scan tool, read and record the active (current) Diagnostic Trouble Code (DTC) data.
75. Next, use the scan tool to read and record any stored (historical) DTC data.
76. If any SRS related DTC is found in the previous two steps, refer to the appropriate diagnostic information.
77. Use the scan tool to erase the stored DTC data. If any problems remain, the stored DTC data will not erase. Refer to the appropriate diagnostic information to diagnose any stored DTC that will not erase. If the stored DTC information is successfully erased, continue to the next step.
78. Transition the status of the ignition switch to OFF for about 15 seconds, and then back to ON. Observe the airbag indicator in the instrument cluster. It should light from four to six seconds, and then go out. This indicates that the SRS is functioning normally and that the repairs are complete. If the airbag indicator fails to light, or lights and stays ON, there is still an active SRS fault or malfunction. Refer to the appropriate diagnostic information to diagnose the problem.
79. Install the front seat headrests (Figure 43).
80. Position the locating tab of the A-pillar trim panel (2) into the slot located in the top of the instrument panel (Figure 42).
81. Install the A-pillar trim panel onto the A-pillar (1) and install the two bolts (4). Tighten the bolts to 5 N·m (44 in. lbs.) (Figure 42).
82. Close the two fastener covers (3) located in the A-pillar trim panel (Figure 42).
83. Install the door seals around the door openings.
84. Return the vehicle to the customer or inventory.

Service Procedure [Continued]

D. Mega Cab

1. Using a small flat-bladed tool, carefully open the two fastener covers (3) located in the A-pillar trim panel (2) (Figure 66).
2. Remove the two bolts (4) that secure the A-pillar trim panel to the A-pillar (1) and remove the trim panel (Figure 66).

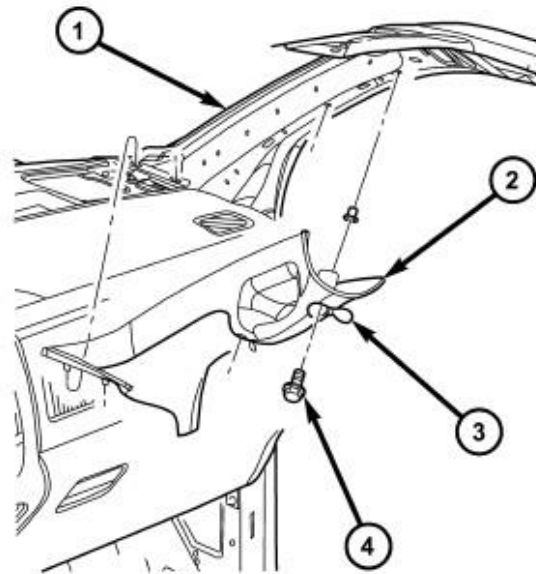

80d407a9

Figure 66 – A-Pillar

3. Push in the buttons on front seat headrest sleeves then pull the headrest up and remove (Figure 67).

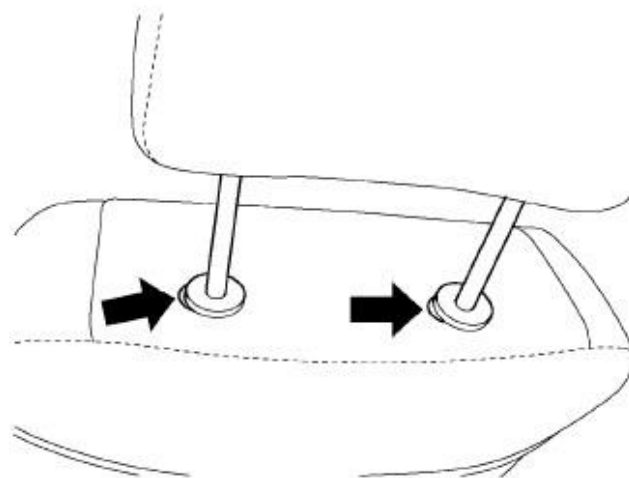

812oddd3

Figure 67 – Head Rest

4. Fold the seats forward.

Service Procedure [Continued]

5. Release the front and rear door sill scuff plates on either side of the B-pillar lower trim panel to allow for removal of the B-pillar lower trim panel (Figure 68).



Front Door Sill



Rear Door Sill

Figure 68 – Door Sill Scuff Plates

6. Release the retaining clips and remove the B-pillar lower trim panel to allow for removal of the B-pillar upper trim panel (Figure 69).

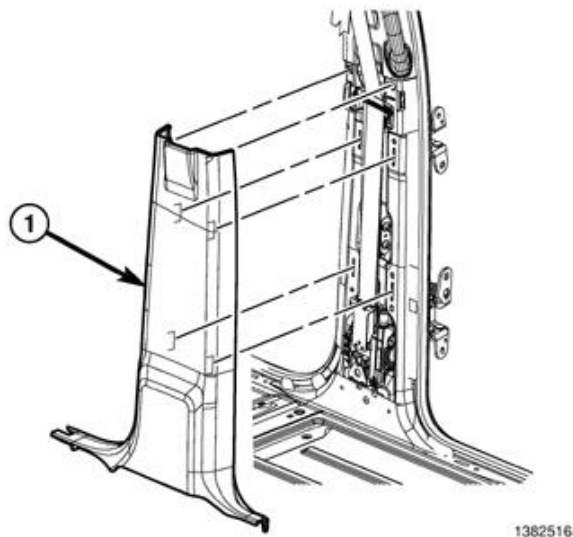

Figure 69 – B-Pillar Lower Trim Panel

Service Procedure [Continued]

7. On the B-pillar, separate the seatbelt turning loop cover then remove the turning loop bolt (Figure 70).

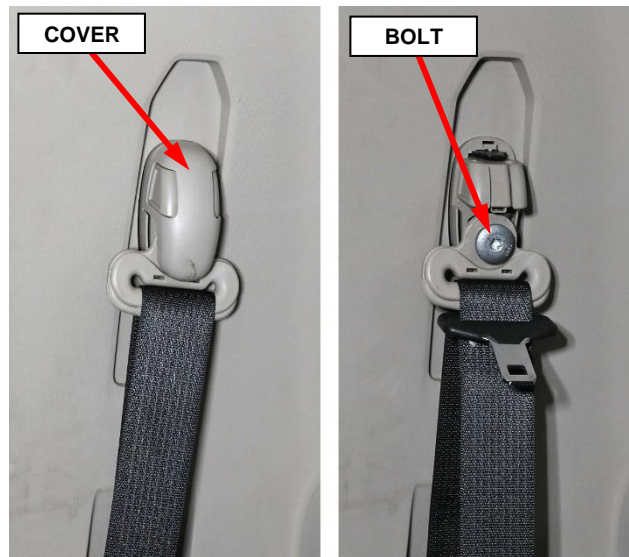

Figure 70 – Seat Belt Turning Loop

8. On the B-pillar, use a small flat-bladed tool to carefully open the two fastener covers (2) located on the grab handle (Figure 71).

9. Remove the two bolts (3) that secure the grab handle to the B-pillar (Figure 71).

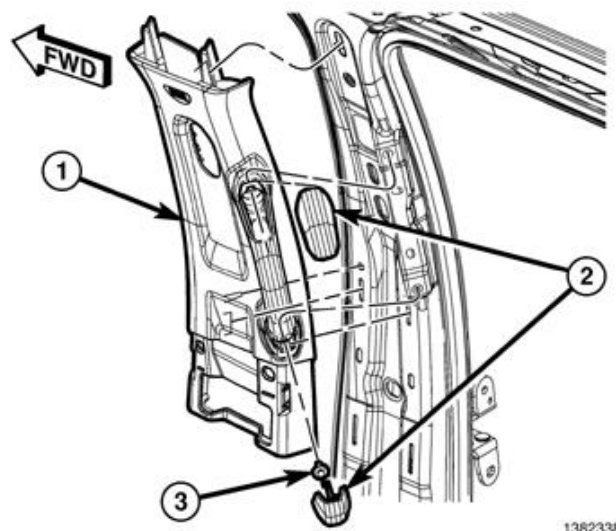

Figure 71 – B-Pillar Upper Trim Panel

10. Using a trim stick C-4755 or equivalent, release the retaining clips that secure the B-pillar upper trim panel (1) then position the trim panel out of the way. It is not necessary to remove the seat belt from the trim panel (Figure 71).

Service Procedure [Continued]

11. Fold the rear seat backs down.
12. Release the upper retaining clips of the lower C-pillar trim panel to allow for removal of the upper C-pillar trim panel (Figure 72).



Figure 72 – C-Pillar Lower Trim Panel

13. On the C-pillar, lift the seat belt turning loop cover then remove the turning loop bolt (Figure 73).

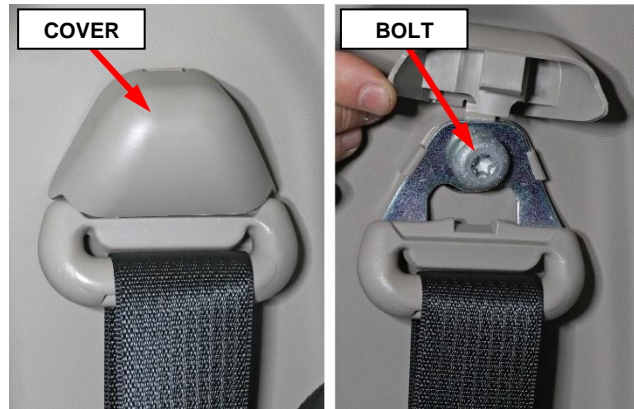

Figure 73 – Seat Belt Turning Loop

Service Procedure [Continued]

14. Using a trim stick or equivalent, release the B-pillar airbag applique then remove the screw that secures the upper trim panel (Figure 74).

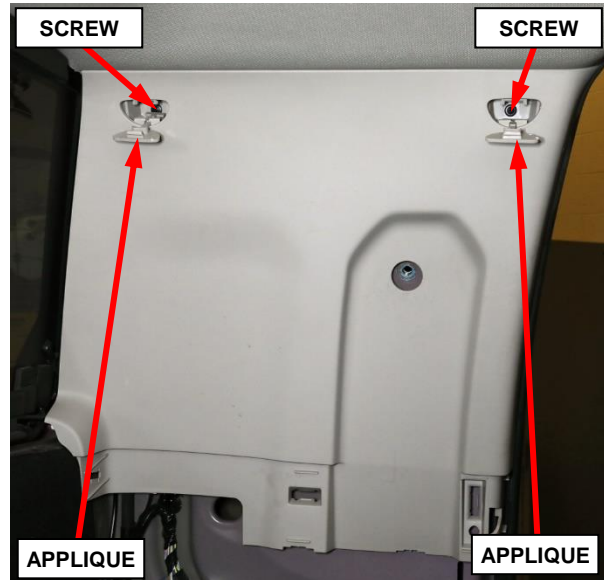

Figure 74 – C-Pillar Upper Trim Panel Fasteners

15. Release the retaining clips and remove the C-pillar upper trim panel (1) (Figure 75).

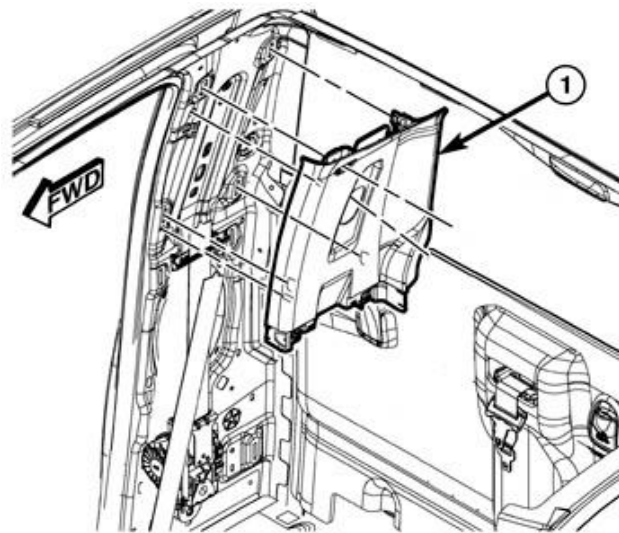

Figure 75 – C-Pillar Upper Trim Panel

16. Recline the front seat backs to allow for room to lower the headliner.

Service Procedure [Continued]

17. Disconnect and isolate the negative battery cable. If equipped with an Intelligent Battery Sensor (IBS), disconnect the IBS connector first before disconnecting the negative battery cable. Wait two minutes for the system capacitor to discharge before further service.

WARNING: To avoid serious or fatal injury on vehicles equipped with airbags, disable the Supplemental Restraint System (SRS) before attempting any steering wheel, steering column, airbag, seat belt tensioner, impact sensor or instrument panel component diagnosis or service. Disconnect and isolate the battery negative (ground) cable, then wait two minutes for the system capacitor to discharge before performing further diagnosis or service. This is the only sure way to disable the SRS. Failure to take the proper precautions could result in accidental airbag deployment.

WARNING: To avoid serious or fatal injury when removing a deployed airbag, rubber gloves, eye protection, and a long-sleeved shirt should be worn. There may be deposits on the airbag unit and other interior surfaces. In large doses, these deposits may cause irritation to the skin and eyes.

WARNING: To avoid serious or fatal injury, use extreme care to prevent any foreign material from entering the side curtain airbag, or becoming entrapped between the side curtain airbag cushion and the headliner. Failure to observe this warning could result in occupant injuries upon airbag deployment.

NOTE: The following procedure is for replacement of an ineffective or damaged side curtain airbag (also known as Side Air Bag Inflatable Curtain/SABIC). If the airbag is ineffective or damaged, but not deployed, review local ordinances regarding recommended procedures for handling and disposal of Non-Deployed Supplemental Restraints.

NOTE: If a side curtain airbag is being removed, but has not been deployed, the headliner does not need to be removed from the passenger compartment. Lowering the headliner and resting it on the seat backs will allow enough clearance to remove the side curtain airbag from the vehicle.

Service Procedure [Continued]

CAUTION: Hands should be clean or clean cloth gloves used when handling the visors and headliner to avoid marks or damage.

18. If equipped with DVD monitor, remove the screws (2) and separate the monitor (1) from the roof (Figure 76).

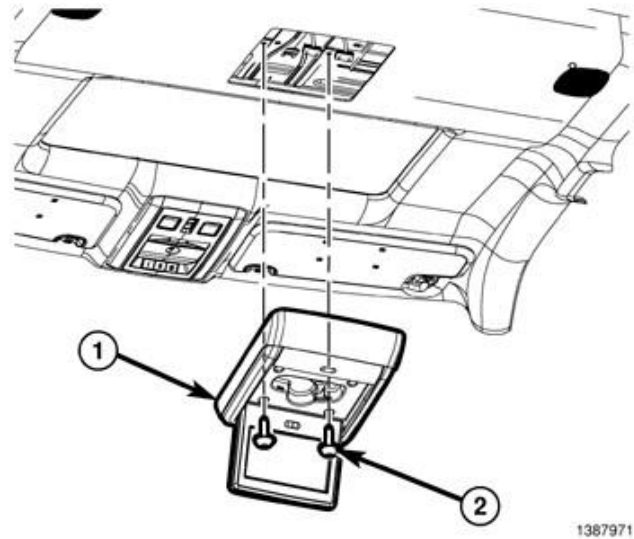

Figure 76 – Rear Seat DVD Monitor

19. If equipped with DVD monitor, disconnect the electrical connectors (1) (Figure 77).

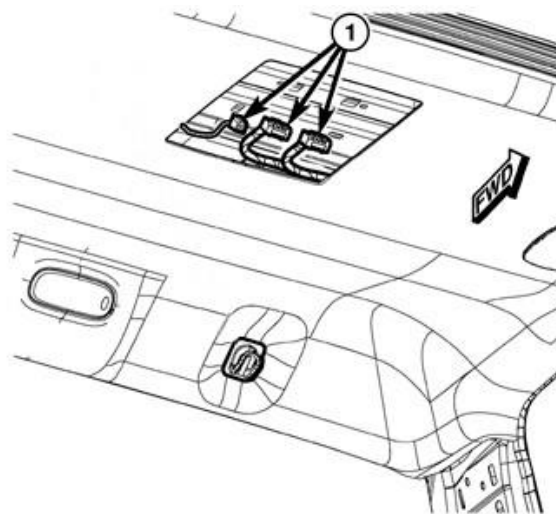

Figure 77 – DVD Monitor Electrical Connectors

Service Procedure [Continued]

20. Separate the visor from the support (1) then remove the screw and remove the visor support (Figure 78).

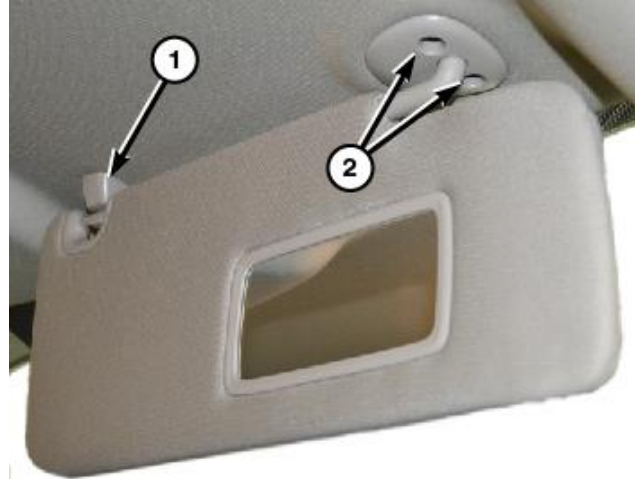

Figure 78 – Visors

21. Remove the visor screws (2) then remove the visor (Figure 78).

Using a small flat bladed tool or equivalent, release the retaining tabs (1) and separate the visor from the headliner (Figure 79).

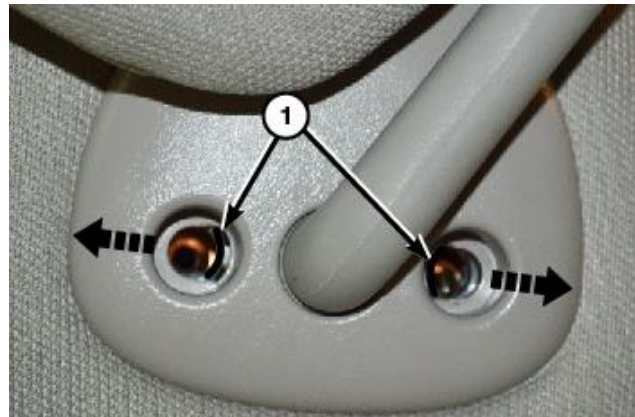

Figure 79 – Visors

22. Disconnect the visor electrical connector if equipped.

NOTE: In some cases, the wire harness for the visor vanity mirror may be glued to the top side of the headliner and may be a little difficult to release.

23. Using a small flat bladed tool, open the coat hook screw cover (2) then remove the screw and coat hook (Figure 80).

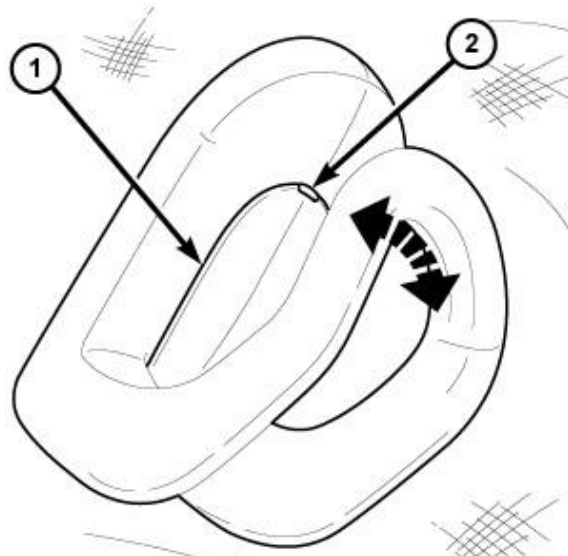

Figure 80 – Coat Hook

Service Procedure [Continued]

24. As necessary, release the headliner wiring harness clips (3) from the A-pillar to allow enough wiring harness slack for lowering the headliner (Figure 81).

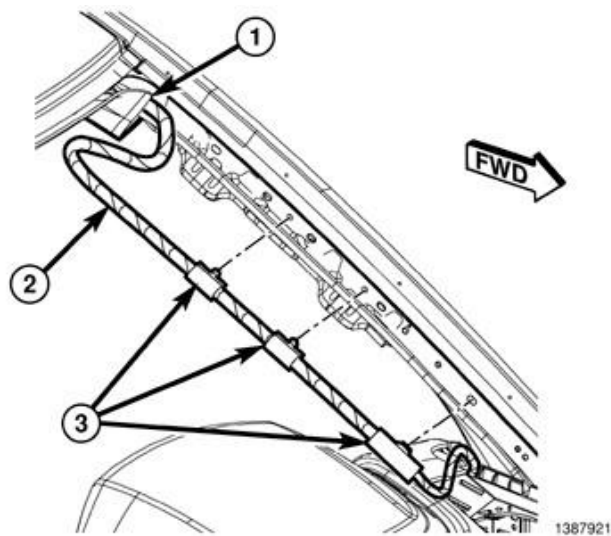

Figure 81 – Headliner Harness

25. Release the door seals from the door openings in order to allow for lowering of the headliner.

26. Carefully lower the headliner (2) allowing it to rest on the seat backs and instrument panel (Figure 82).

CAUTION: Disconnect any wiring harness electrical connectors (1) as necessary to allow enough wiring harness slack while lowering headliner. It will not be necessary to remove the headliner from the vehicle (Figure 82).

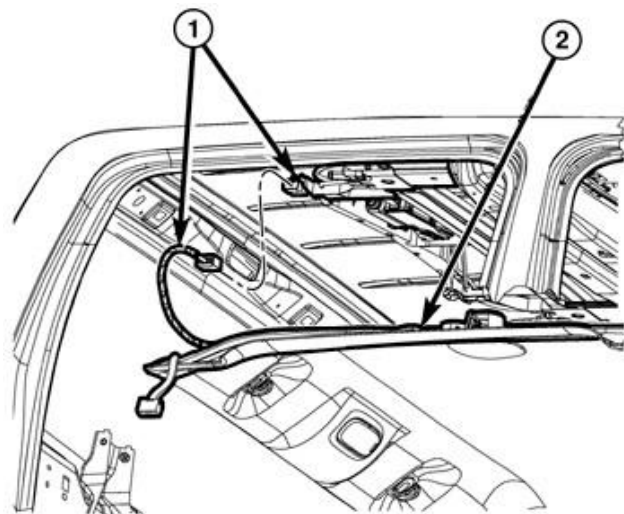
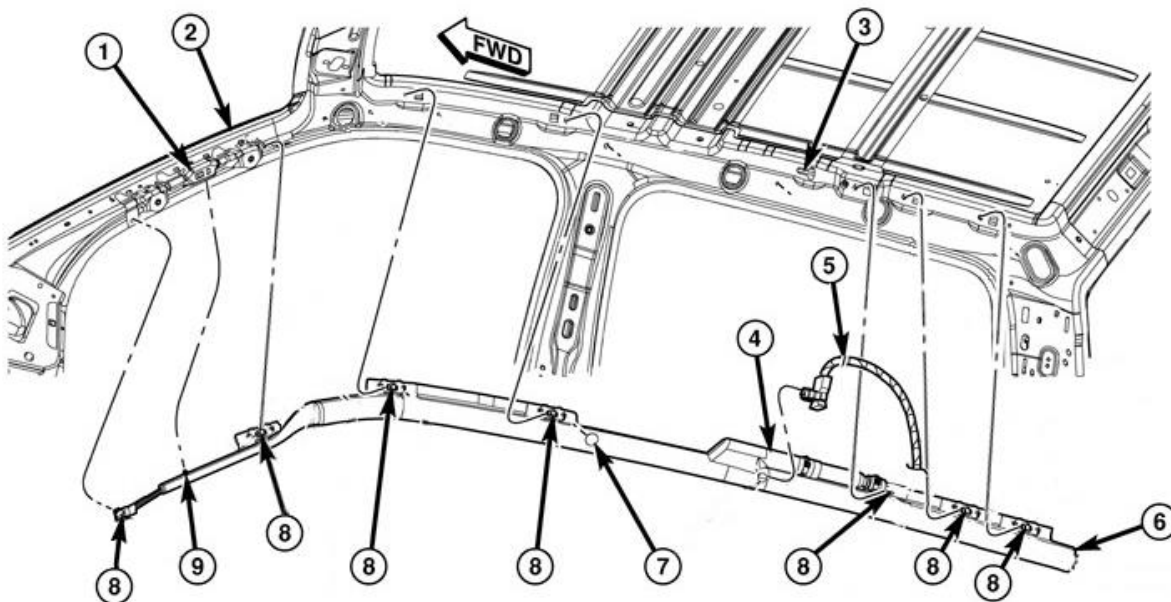

Figure 82 – Headliner Harness

27. Obtain the appropriate replacement SABIC(s) for the vehicle based on its VIN.

Service Procedure [Continued]

28. The body wire harness connector (5) is secured by integral latches to the connector receptacle on the inflator (4). Pinch both latches firmly, then pull the connector straight out from the airbag inflator to disconnect it from the connector receptacle (Figure 83).
29. Remove the seven bolts (8) that secure the side curtain airbag (6) to the inner roof rail and A-pillar (Figure 83).
30. Disengage the plastic push-in retainer (9) that secures the side curtain airbag tether to the inner A-pillar (1) and the plastic push-in retainer (7) that secures the side curtain airbag to the inner roof rail (Figure 83).
31. Slide the inflator rearward far enough to disengage the T-tab at the front of the inflator bracket from the keyed T-slot in the inner roof rail over the rear door opening (Figure 84).
32. Remove the SABIC (6) from the vehicle as a unit and **DISCARD** following local ordinances and recommended procedures for handling and disposal of Non-Deployed Supplemental Restraints (Figure 83). Provided packaging is not authorized for the transport of the recalled SABIC Module. Parts will need to be either deployed on-site or transported in alternative approved containers.

**Figure 83 – SABIC**

Service Procedure [Continued]

Figure 84 – SABIC Inflator T-Tab and Inner Roof Rail T-Slot

33. Check to be certain that the spring nuts are properly installed in the inner roof rail and that they are in good condition.
34. Position the **NEW SABIC** (6) into the vehicle as a unit (Figure 83).
35. Insert the T-tab at the front of the inflator bracket into the keyed T-slot in the inner roof rail over the rear door opening and slide the inflator forward to engage it (Figure 84).
36. Engage the plastic push-in retainer (7) that secures the side curtain airbag to the inner roof rail and ensure the tether is not twisted then engage the plastic push-in retainer (9) that secures the side curtain airbag front tether to the assist handle bracket on the inner A-pillar (1) (Figure 83).
37. Working from rear to front, install and tighten the seven bolts (8) that secure the side curtain airbag (6) to the inner roof rail and A-pillar. Tighten the bolts to 7 N·m (62 in. lbs.) (Figure 83).
38. Connect the body wire harness connector (5) for the side curtain airbag to the connector receptacle of the inflator (4). Be certain that each connector is fully engaged in its receptacle by listening carefully for a distinct, audible click as the connector latches snap into place (Figure 83).

Service Procedure [Continued]

CAUTION: Hands should be clean or clean cloth gloves used when handling the headliner to avoid damage to the headliner.

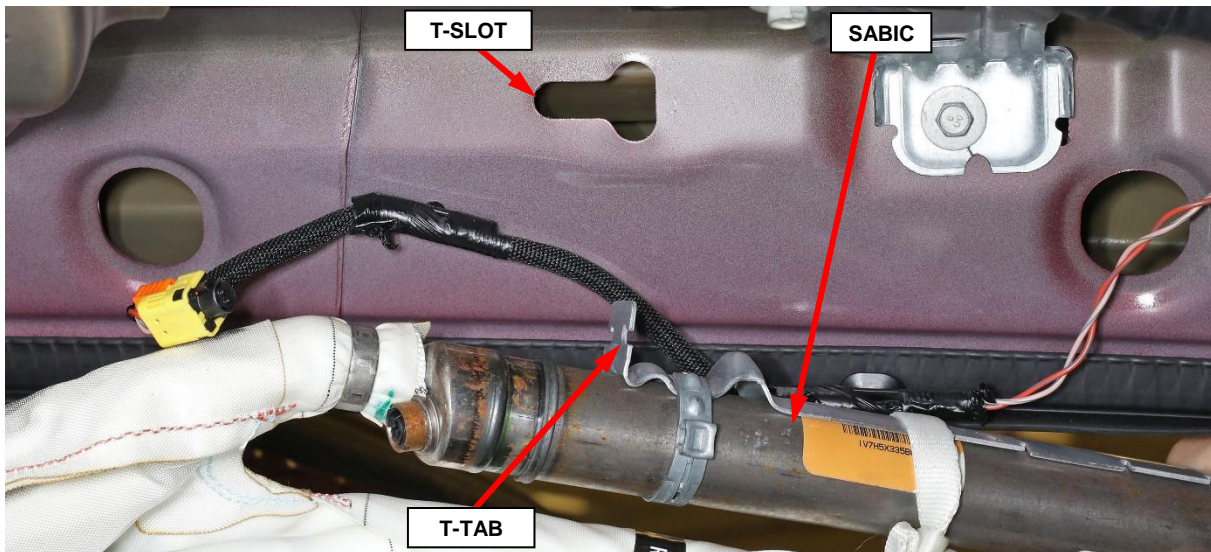
39. Raise the headliner into proper vehicle position and connect any electrical connectors previously disconnected from the headliner (Figure 82).

CAUTION: Be certain to avoid any wiring or drain tube interference.

40. Position the coat hooks (5) onto the headliner and install the screws tightening securely into the mounting clips then close the screw cap fully (Figure 80).
41. Position the visor supports (1) onto the headliner and install the screws into the mounting clips (Figure 78).
42. If equipped with illuminated vanity mirror, connect the wire harness connector.
43. Position the visor to the headliner and install the screws (2) that secure the visor to the roof panel. Tighten the screws to 6 N·m (53 in. lbs.) (Figure 78).
44. Reattach any headliner wiring harness clips (3) removed from the A-pillar to allow slack while lowering headliner (Figure 81).
45. If equipped with DVD monitor, connect the DVD monitor electrical connectors (1) (Figure 77). Position the DVD monitor to the roof then install and tighten the screws (2) (Figure 76).

WARNING: Do not connect the negative battery cable at this time. The Supplemental Restraint System (SRS) Verification Test procedure should be performed following service of any SRS component.

NOTE: The following procedure should be performed using a diagnostic scan tool to verify proper Supplemental Restraint System (SRS) operation following the service or replacement of any SRS component. Refer to the appropriate diagnostic procedures.

Service Procedure [Continued]

46. During the following test, the negative cable remains disconnected and isolated from the battery, as it was during the Supplemental Restraint System (SRS) component removal and installation procedures.
47. Be certain that the diagnostic scan tool contains the latest version of the proper diagnostic software. Connect the scan tool to the 16-way Data Link Connector (DLC). The DLC is located on the driver side lower edge of the instrument panel, near the steering column opening cover and outboard of the steering column.
48. Transition the status of the ignition switch (also known as the Keyless Ignition Node/KIN or IGnition Node Module/IGNM) to ON and exit the vehicle with the scan tool.
49. Check to be certain that nobody is in the vehicle, then connect the negative cable to the battery.
50. Using the scan tool, read and record the active (current) Diagnostic Trouble Code (DTC) data.
51. Next, use the scan tool to read and record any stored (historical) DTC data.
52. If any SRS related DTC is found in the previous two steps, refer to the appropriate diagnostic information.
53. Use the scan tool to erase the stored DTC data. If any problems remain, the stored DTC data will not erase. Refer to the appropriate diagnostic information to diagnose any stored DTC that will not erase. If the stored DTC information is successfully erased, continue to the next step.
54. Transition the status of the ignition switch to OFF for about 15 seconds, and then back to ON. Observe the airbag indicator in the instrument cluster. It should light from four to six seconds, and then go out. This indicates that the SRS is functioning normally and that the repairs are complete. If the airbag indicator fails to light, or lights and stays ON, there is still an active SRS fault or malfunction. Refer to the appropriate diagnostic information to diagnose the problem.

Service Procedure [Continued]

55. Raise the front seat backs and position the seats forward.
56. Install the C-pillar upper trim panel (1) and engage the retaining clips fully (Figure 75).
57. Install and tighten the screws that secure the C-pillar upper trim panel then install the airbag applique covers (Figure 74).
58. Remove and **DISCARD** the bolt retainer and the bolt from the seat belt turning loop, save the spacer for reuse (Figure 85).
59. Using a **NEW** bolt and reusing the spacer washer, install the turning loop then tighten the bolt to 40 N·m (30 ft. lbs.) (Figure 73).
60. Install the seat belt turning loop cover (Figure 73).
61. Position the lower C-pillar trim panel and engage the retaining clips fully (Figure 72).

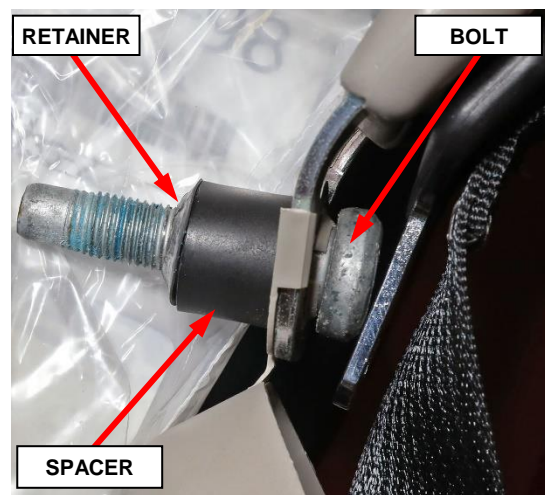
**Figure 85 – Turning Loop Bolt**

NOTE: Ensure that all C-pillar fasteners are installed/engaged properly.

62. Install the B-pillar upper trim panel (1) and engage the retaining clips fully (Figure 71).
63. Install the grab handle bolts and tighten to 5 N·m (44 in. lbs.). Close the fastener covers (2) (Figure 71).

Service Procedure [Continued]

64. Remove and **DISCARD** the bolt retainer and the bolt from the seat belt turning loop, save the spacer washer for reuse (Figure 86).

65. Using a **NEW** bolt and reusing the spacer washer, install the turning loop then tighten the bolt to 40 N·m (30 ft. lbs.) (Figure 70).

66. Install the seat belt turning loop cover (Figure 70).

67. Position the B-pillar lower trim panel and engage the retaining clips fully (Figure 69).

68. Position the front and rear door sill scuff plates and engage the retainers (Figure 68).

69. Install the front seat headrests (Figure 67).

70. Position the locating tab of the A-pillar trim panel (2) into the slot located in the top of the instrument panel (Figure 66).

71. Install the A-pillar trim panel onto the A-pillar (1) and install the two bolts (4). Tighten the bolts to 5 N·m (44 in. lbs.) (Figure 66).

72. Close the two fastener covers (3) located in the A-pillar trim panel (Figure 66).

73. Install the door seals around the door openings.

74. Return the vehicle to the customer or inventory.

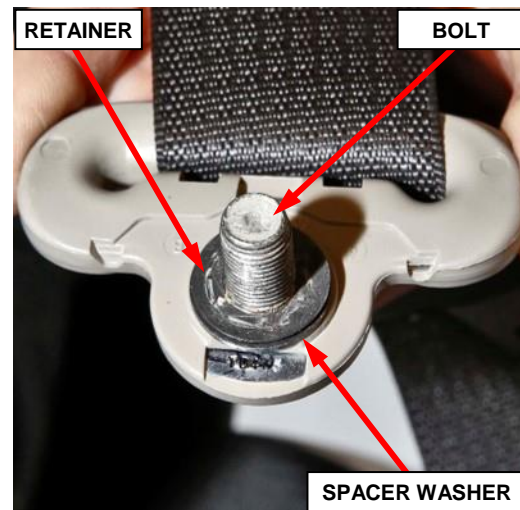

Figure 86 – Turning Loop Bolt

Completion Reporting and Reimbursement

Claims for vehicles that have been serviced must be submitted on the DealerCONNECT Claim Entry Screen located on the Service tab. Claims paid will be used by FCA to record recall service completions and provide dealer payments.

Use the following labor operation numbers and time allowances:

	Labor Operation Number	Time Allowance
Replace One SABIC (Standard Cab)	23-Y9-91-82	1.4 hours
Replace One SABIC (Crew/Quad Cab)	23-Y9-91-83	2.5 hours
Replace One SABIC (Mega Cab)	23-Y9-91-84	2.2 hours
 Floor Plan Reimbursement	 95-95-95-97	 Calculate See Below

Floor Plan Reimbursement represents the vehicle’s average daily allowance (see table below) multiplied by the number of days the vehicle was in dealer inventory and not available for sale. This reimbursement is limited to the number of days from the date of the stop sale to the date that the remedy was made available. Note: If the vehicle was received by your dealership (KZX date) AFTER the stop sale date, you will use the KZX date instead of the stop sale date. For this Recall, the stop sale was initiated on **12/02/2021** and the remedy was made available on **01/13/2022**, therefore, the number of days cannot exceed **42** days.

Vehicle	Average Daily Allowance
2021 (DS) Ram 1500 Pickup	
2021 - 2022 (DJ) Ram 2500 Pickup	
2021 - 2022 (D2) Ram 3500 Pickup	

NOTE: See the Warranty Administration Manual, Recall Claim Processing Section, for complete recall claim processing instructions.

Dealer Notification

To view this notification on DealerCONNECT, select “Global Recall System” on the Service tab, then click on the description of this notification.

Owner Notification and Service Scheduling

All involved vehicle owners known to FCA are being notified of the service requirement by first class mail. They are requested to schedule appointments for this service with their dealers. A generic copy of the owner letter is attached.

Vehicle Lists, Global Recall System, VIP and Dealer Follow Up

All involved vehicles have been entered into the DealerCONNECT Global Recall System (GRS) and Vehicle Information Plus (VIP) for dealer inquiry as needed.

GRS provides involved dealers with an updated VIN list of their incomplete vehicles. The owner’s name, address and phone number are listed if known. Completed vehicles are removed from GRS within several days of repair claim submission.

To use this system, click on the “**Service**” tab and then click on “**Global Recall System.**” Your dealer’s VIN list for each recall displayed can be sorted by: those vehicles that were unsold at recall launch, those with a phone number, city, zip code, or VIN sequence.

Dealers must perform this repair on all unsold vehicles before retail delivery. Dealers should also use the VIN list to follow up with all owners to schedule appointments for this repair.

Recall VIN lists may contain confidential, restricted owner name and address information that was obtained from the Department of Motor Vehicles of various states. Use of this information is permitted for this recall only and is strictly prohibited from all other use.

Additional Information

If you have any questions or need assistance in completing this action, please contact your Service and Parts District Manager.

This notice applies to your vehicle,

[Model Year and Model]

VIN XXXXXXXXXXXXXXXXXXXX

Y99/NHTSA 21V-925

LOGO

VEHICLE PICTURE

YOUR SCHEDULING OPTIONS

1. RECOMMENDED OPTION

Call your authorized Chrysler / Dodge / Jeep® / RAM Dealership

2. Call the FCA Recall Assistance

Center at 1-800-853-1403. An agent can confirm part availability and help schedule an appointment

3. Visit recalls.mopar.com, scan the

QR code below, or download the Mopar Owner's Companion App.

QR Code

Get access to recall notifications, locate your nearest dealer, and more through this website or Mopar Owner's Companion App. You will be asked to provide your Vehicle Identification Number (VIN) to protect and verify your identity. The last eight characters of your VIN are provided above.

DEALERSHIP INSTRUCTIONS

Please reference Safety Recall Y99.

IMPORTANT SAFETY RECALL

Side Air Bag Inflatable Curtain Inflator

Dear [Name],

This notice is sent to you in accordance with the National Traffic and Motor Vehicle Safety Act.

FCA US has decided that a defect, which relates to motor vehicle safety, exists in certain [2021 (DS) Ram 1500 Pickup and 2021 – 2022 (DJ) Ram 2500 Pickup, (D2) Ram 3500 Pickup] vehicles.

It is extremely important to take steps now to repair your vehicle to ensure the safety of you and your passengers.

WHY DOES MY VEHICLE NEED REPAIRS?

Your vehicle ^[1] may have been built with a Side Air Bag Inflatable Curtain (SABIC) assembly containing an inflator with out of specification propellant gas mass. SABIC assemblies with low gas mass may result in non-deployment or low/slow deployment and high gas mass may result in aggressive deployment of the air bag which may increase the risk of occupant injury in certain crashes.

HOW DO I RESOLVE THIS IMPORTANT SAFETY ISSUE?

FCA US will repair your vehicle ^[2] free of charge (parts and labor). To do this, your dealer will replace the Side Air Bag Inflatable Curtain (SABIC) assembly. The estimated repair time is about 3 hours. In addition, your dealer will require your vehicle for proper check-in, preparation, and check-out during your visit, which may require more time. Your time is important to us, so we recommend that you schedule a service appointment to minimize your inconvenience. Please bring this letter with you to your dealership.

**TO SCHEDULE YOUR FREE REPAIR,
CALL YOUR CHRYSLER, DODGE, JEEP OR RAM DEALER TODAY**

WHAT IF I ALREADY PAID TO HAVE THIS REPAIR COMPLETED?

If you have already experienced this specific condition and have paid to have it repaired, you may visit www.fcarecallreimbursement.com to submit your reimbursement request online. ^[3] Once we receive and verify the required documents, reimbursement will be sent to you within 60 days. If you have had previous repairs performed and/or already received reimbursement, you may still need to have the recall repair performed.

We apologize for any inconvenience, but are sincerely concerned about your safety. Thank you for your attention to this important matter.

Customer Assistance/Field Operations
FCA US LLC



Mr. Mrs. Customer
1234 Main Street
Hometown, MI 48371

[1] If you no longer own this vehicle, please help us update our records. Call the FCA Recall Assistance Center at 1-800-853-1403 to update your information.

[2] If your dealer fails or is unable to remedy this defect without charge and within a reasonable time, you may submit a written complaint to the Administrator, National Highway Traffic Safety Administration, 1200 New Jersey Ave., S.E., Washington, DC 20590, or you can call the toll-free Vehicle Safety Hotline at 1-888-327-4236 (TTY 1-800-424-9153), or go to safercar.gov.

[3] You can also mail in your original receipts and proof of payment to the following address for reimbursement consideration: FCA Customer Assistance, P.O. Box 21-8004, Auburn Hills, MI 48321-8007, Attention: Recall Reimbursement.

Note to lessors receiving this recall notice: Federal regulation requires that you forward this recall notice to the lessee within 10 days.