

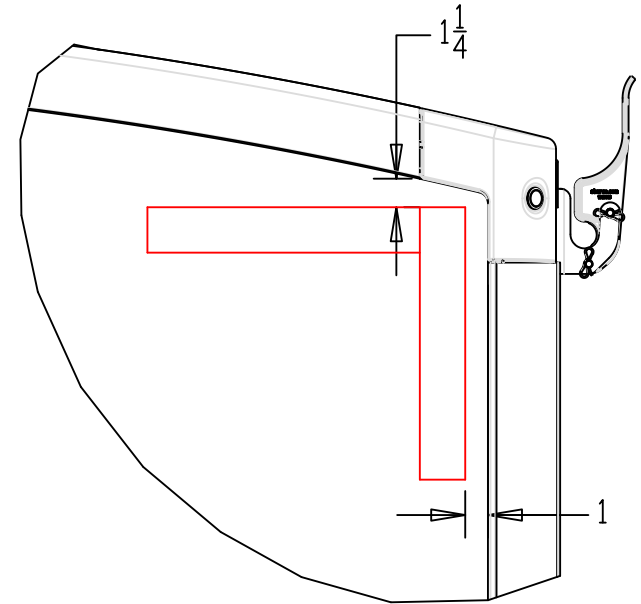

SEE DETAIL A

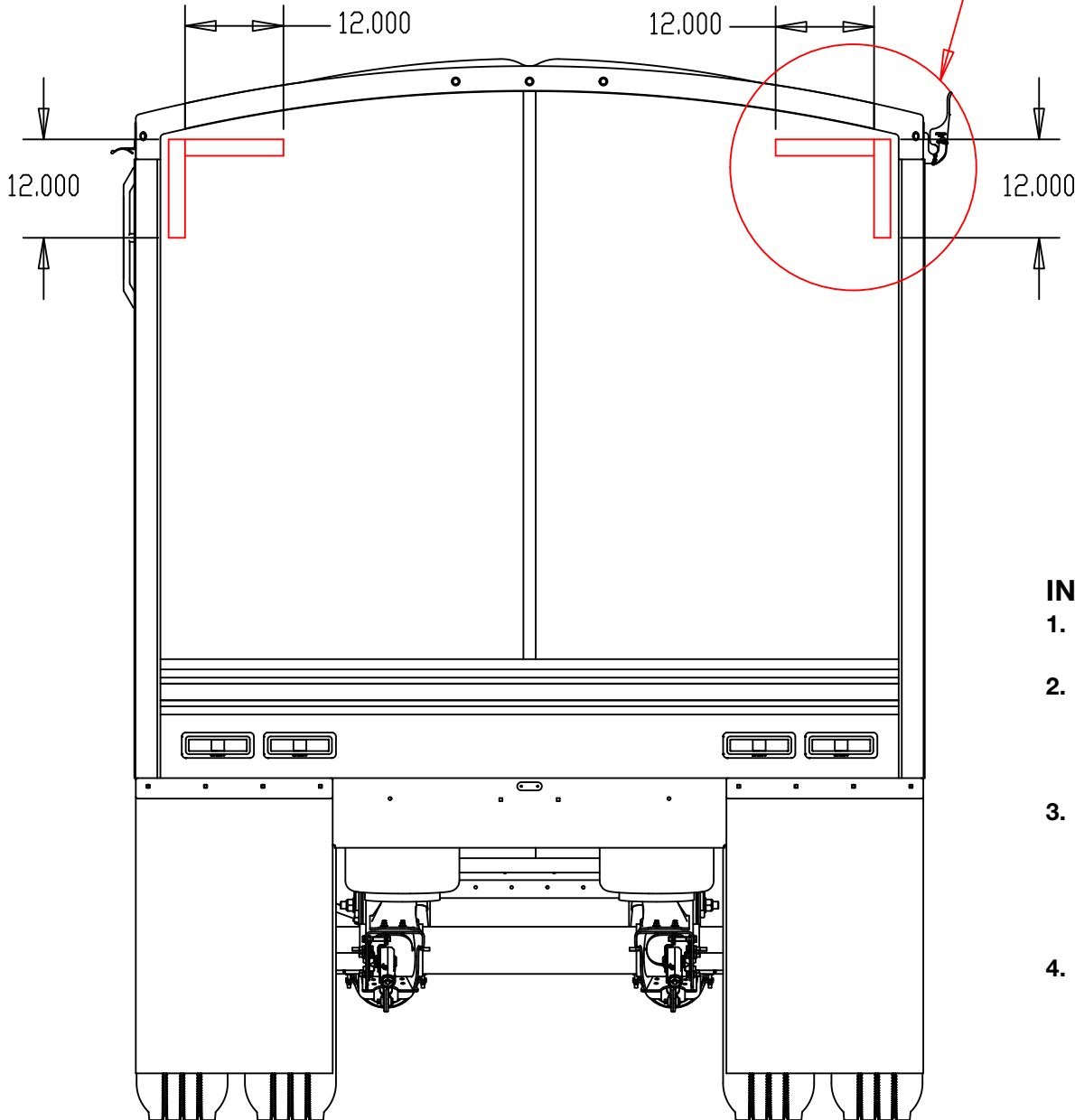

DETAIL A
SCALE 0.125

INSTRUCTIONS

1. Ensure rear of trailer is washed, then rinsed with clean water.
2. Using the alcohol wipes provided, clean an area 12 inches long, 12 inches in height, by at least 3 inches wide to both top corners on rear of trailer as indicated in the drawing.
3. Partially remove the backing of the tape strip revealing the adhesive portion. Firmly press the tape in place, slowly removing the backing completely. This step should be completed 3 additional times until all 4 pieces of tape are installed per the drawing.
4. Use the tape backing piece to firmly rub each applied tape strip in ensure complete adhesion.