



# Safety Recall

## Code: 40R7

<b>Subject</b>	Front Wheel Bearing Bolts																									
<b>Release Date</b>	October 26, 2021																									
<b>Affected Vehicles</b>	<table border="1"><thead><tr><th>Country</th><th>Beginning Model Year</th><th>Ending Model Year</th><th>Vehicle</th><th>Vehicle Count</th></tr></thead><tbody><tr><td>USA</td><td>2021</td><td>2021</td><td>ATLAS</td><td>15</td></tr><tr><td>USA</td><td>2021</td><td>2021</td><td>ATLAS CROSS SPORT</td><td>12</td></tr><tr><td>USA</td><td>2021</td><td>2021</td><td>PASSAT</td><td>3</td></tr><tr><td>CAN</td><td>2021</td><td>2021</td><td>ATLAS</td><td>3</td></tr></tbody></table>	Country	Beginning Model Year	Ending Model Year	Vehicle	Vehicle Count	USA	2021	2021	ATLAS	15	USA	2021	2021	ATLAS CROSS SPORT	12	USA	2021	2021	PASSAT	3	CAN	2021	2021	ATLAS	3
Country	Beginning Model Year	Ending Model Year	Vehicle	Vehicle Count																						
USA	2021	2021	ATLAS	15																						
USA	2021	2021	ATLAS CROSS SPORT	12																						
USA	2021	2021	PASSAT	3																						
CAN	2021	2021	ATLAS	3																						
	<p>Check Campaigns/Actions screen in ELSA on the day of repair to verify that a VIN qualifies for repair under this action. ELSA is the <u>only</u> valid campaign inquiry &amp; verification source.</p> <ul style="list-style-type: none"><li>✓ Campaign status must show "open."</li><li>✓ If ELSA shows other open action(s), inform your customer so that the work can also be completed at the same time the vehicle is in the workshop for this campaign.</li></ul>																									
<b>Problem Description</b>	On a small population of vehicles, the front wheel bearing bolts may have been incorrectly tightened by the supplier. If this condition is present in the vehicle, the bolts may loosen over time and adversely affect the driver's control over the vehicle, potentially causing a crash.																									
<b>Corrective Action</b>	Inspect and, if necessary, replace the affected front wheel bearing bolt(s).																									
<b>Precautions</b>	If the front wheel bearing bolts have loosened, vehicle occupants may notice unusual noise coming from the front of the vehicle. If this should occur, customers are advised to contact an authorized Volkswagen dealer without delay and make arrangements to have the vehicle diagnosed/repared.																									
<b>Code Visibility</b>	On or about October 26, 2021, the campaign code will be applied to affected vehicles.																									
<b>Owner Notification</b>	Owner notification will take place in November 2021. Owner letter examples are included in this bulletin for your reference.																									
<b>Additional Information</b>	<p>Please alert everyone in your dealership about this action, including Sales, Service, Parts and Accounting personnel. Contact Warranty if you have any questions.</p> <p><b>IMPORTANT REMINDER ON VEHICLES AFFECTED BY SAFETY &amp; COMPLIANCE RECALL:</b></p> <p><b><u>New Vehicles in Dealer Inventory:</u> It is a violation of federal law for a dealer to deliver a new motor vehicle or any new or used item of motor vehicle equipment (including a tire) covered by this notification under a sale or lease until the defect or noncompliance is remedied. By law, dealers must correct, prior to delivery for sale or lease, any vehicle</b></p>																									

that fails to comply with an applicable Federal Motor Vehicle Safety Standard or that contains a defect relating to motor vehicle safety.

**Pre-Owned Vehicles in Dealer Inventory: Dealers should not deliver any pre-owned vehicles in their inventory which are involved in a safety or compliance recall until the defect has been remedied.**

Dealers must ensure that every affected inventory vehicle has this campaign completed before delivery to consumers.

Fill out and affix Campaign Completion Label (CAMP 010 000) after work is complete. *Labels can be ordered at no cost via the Compliance Label Ordering portal at [www.vwhub.com](http://www.vwhub.com).*

## Parts Information

**Parts Control Type:**  
**Free Order**

Parts will be managed by Free Order

**Initial Allocation:**  
**NO**

There will be no parts allocation. Please reference the Repair Projection Tool (below) to view your potential VIN population.

Criteria	Quantity	Part Number	P.O.C. Part Description	Ordering Method
01	6	N -912-332-01	NUT (ball joint to control arm – ATLAS)	Free Order
	6	N -103-320-02	NUT (ball joint to control arm – PASSAT)	Free Order
	2	WHT-005-437-A	BOLT (axle bolt – all models)	Free Order
	<i>Use the following parts ONLY if necessary:</i>			
	Up to 8	WHT-004-835	BOLT (wheel bearing to housing – ATLAS)	Free Order
	Up to 8	WHT-000-237-C	BOLT (wheel bearing to housing – PASSAT)	Free Order

### NOTE

The specified part numbers reflect the status at the start of this action. Interim updates made in ETKA can cause a listed part number to become unavailable. In this case, the new part number specified in ETKA should be used.

## Claim Entry Instructions

The labor times listed here may differ from the labor operations and labor times listed in ELSA.

After campaign has been completed, enter claim as soon as possible to help prevent work from being duplicated elsewhere. Attach the ELSA screen print showing action open on the day of repair to the repair order.

If customer refused campaign work:

- ✓ U.S. dealers: Submit request via WISE under the *Campaigns/Update/Recall Closure* option.
- ✓ Canada dealers: Upload the repair order [signed by customer] to Volkswagen WIN/Operations/Campaign Closure.

<b>Service Number</b>	40R7		
<b>Damage Code</b>	0099		
<b>Parts Vendor Code</b>	WWO		
<b>Claim Type</b>	Sold vehicle: 7 10 Unsold vehicle: 7 90		
<b>Causal Indicator</b>	Mark labor as causal		
<b>Vehicle Wash/Loaner</b>	<p>Do not claim wash/loaner under this action</p> <p><b>U.S.A.:</b> Loaner/rental coverage cannot be claimed under this action. However, loaner/rental may be covered under the Alternate Transportation Program. Please refer to the Volkswagen Warranty Policy and Procedures Manual for loaner claims information and reimbursement details.</p> <p><b>Canada:</b> Loaner/rental coverage cannot be claimed under this action. Please refer to Volkswagen Service Loaner Program to determine loaner eligibility.</p>		
<b>Criteria I.D.</b>	01		
<b>Model</b>	Atlas		
	Check torque on front wheel bearing bolts. All bolts are ok. No further work is required.		
	<b>LABOR</b>		
	<b>Labor Op</b>	<b>Time Units</b>	<b>Description</b>
	0183 00 99	100	Inspect wheel bearing bolts
	<b>PARTS</b>		
	<b>Quantity</b>	<b>Part Number</b>	<b>Description</b>
	6.00	N 91233201	NUT
	2.00	WHT005437A	BOLT

Continued on next page

<b>-OR-</b>	Check torque on front wheel bearing bolts. One or more wheel bearing bolts requires replacement.		
	<b>LABOR</b>		
	<b>Labor Op</b>	<b>Time Units</b>	<b>Description</b>
	4067 49 99	100	Inspect and replace one or more wheel bearing bolts
	<b>PARTS</b>		
	<b>Quantity</b>	<b>Part Number</b>	<b>Description</b>
	6.00	N 91233201	NUT
	2.00	WHT005437A	BOLT
	Up to 8	WHT004835	BOLT
<b>Criteria I.D.</b>	01		
<b>Model</b>	Passat		
	Check torque on front wheel bearing bolts. All bolts are ok. No further work is required.		
	<b>LABOR</b>		
	<b>Labor Op</b>	<b>Time Units</b>	<b>Description</b>
	0183 00 99	100	Inspect wheel bearing bolts
	<b>PARTS</b>		
	<b>Quantity</b>	<b>Part Number</b>	<b>Description</b>
	6.00	N 10332002	NUT
	2.00	WHT005437A	BOLT
<b>-OR-</b>	Check torque on front wheel bearing bolts. One or more wheel bearing bolts requires replacement.		
	<b>LABOR</b>		
	<b>Labor Op</b>	<b>Time Units</b>	<b>Description</b>
	4067 50 99	100	Inspect and replace one or more wheel bearing bolts
	<b>PARTS</b>		
	<b>Quantity</b>	<b>Part Number</b>	<b>Description</b>
	6.00	N 10332002	NUT
	2.00	WHT005437A	BOLT
	Up to 8	WHT000237C	BOLT

The repair information in this document is intended for use only by skilled technicians who have the proper tools, equipment and training to correctly and safely maintain your vehicle. These procedures are not intended to be attempted by "do-it-yourselfers," and you should not assume this document applies to your vehicle, or that your vehicle has the condition described. To determine whether this information applies, contact an authorized Volkswagen dealer. ©2021 Volkswagen Group of America, Inc. and Volkswagen Canada. All Rights Reserved.

## Customer Letter Example (USA)

<MONTH YEAR>

<CUSTOMER NAME>

<CUSTOMER ADDRESS>

<CUSTOMER CITY STATE ZIPCODE>

**This notice applies to your vehicle:** <MODEL YEAR> <BRAND> <CARLINE>, <VIN>

**NHTSA:** 21V812

**Subject: Safety Recall 40R7 - Front Wheel Bearing Bolts**

Dear Volkswagen Owner,

This notice is sent to you in accordance with the National Traffic and Motor Vehicle Safety Act. Volkswagen has decided that a defect, which relates to motor vehicle safety, exists in certain 2021 model year Volkswagen vehicles. Our records show that you are the owner of a vehicle affected by this action.

**What is the issue?** On a small population of vehicles, the front wheel bearing bolts may have been incorrectly tightened by the supplier. If this condition is present in the vehicle, the bolts may loosen over time and adversely affect the driver's control over the vehicle, potentially causing a crash.

**What will we do?** To correct this defect, your authorized Volkswagen dealer will inspect and, if necessary, replace the affected front wheel bearing bolt(s). This work will take up to two hours to complete and will be performed for you free of charge. Please keep in mind that your dealer may need additional time for the preparation of the repair, as well as to accommodate their daily workshop schedule.

**What should you do?** Please contact your authorized Volkswagen dealer without delay to schedule this recall repair. To set up an appointment online, please visit [www.vw.com/find-a-dealer](http://www.vw.com/find-a-dealer).

**Precautions you should take** If the front wheel bearing bolts have loosened, vehicle occupants may notice unusual noise coming from the front of the vehicle. If this should occur, customers are advised to contact an authorized Volkswagen dealer without delay and make arrangements to have the vehicle diagnosed/repaired.

**Lease vehicles and address changes** If you are the lessor and registered owner of the vehicle identified in this action, the law requires you to forward this letter immediately via first-class mail to the lessee within ten (10) days of receipt. If you have changed your address or sold the vehicle, please fill out the enclosed prepaid Owner Reply card and mail it to us so we can update our records.

**Can we assist you further?** If your authorized Volkswagen dealer fails or is unable to complete this work free of charge within a reasonable time, or if you should have any questions about this communication, please reach out to us using your preferred method of communication at [www.vw.com/contact](http://www.vw.com/contact) or by calling us at 800-893-5298.

**Checking your vehicle for open Recalls and Service Campaigns** To check your vehicle's eligibility for repair under this or any other recall/service campaign, please visit [www.vw.com/owners/recalls](http://www.vw.com/owners/recalls) and enter your Vehicle Identification Number (VIN) into the Recall/Service Campaign Lookup tool.

If you still cannot obtain satisfaction, you may file a complaint with: The Administrator, National Highway Traffic Safety Administration, 1200 New Jersey Avenue, SE., Washington, DC 20590; or call the toll-free Vehicle Safety Hotline at 1-888-327-4236 (TTY: 1-800-424-9153); or go to <http://www.safercar.gov>.

We apologize for any inconvenience this matter may cause; however we are taking this action to help ensure your safety and continued satisfaction with your vehicle.

Sincerely,

Volkswagen Customer Protection

The repair information in this document is intended for use only by skilled technicians who have the proper tools, equipment and training to correctly and safely maintain your vehicle. These procedures are not intended to be attempted by "do-it-yourselfers," and you should not assume this document applies to your vehicle, or that your vehicle has the condition described. To determine whether this information applies, contact an authorized Volkswagen dealer. ©2021 Volkswagen Group of America, Inc. and Volkswagen Canada. All Rights Reserved.

## Customer Letter Example (Canada)

<MONTH YEAR>

<CUSTOMER NAME>

<CUSTOMER ADDRESS>

<CUSTOMER CITY STATE ZIPCODE>

**This notice applies to your vehicle:** <MODEL YEAR> <BRAND> <CARLINE>, <VIN>

**Transport Canada Recall:** 2021-635

**Subject: Safety Recall 40R7 - Front Wheel Bearing Bolts**

Dear Volkswagen Owner,

This notice is sent to you in accordance with the requirements of the *Motor Vehicle Safety Act*. This is to inform you that your vehicle may contain a defect that could affect the safety of a person. Our records show that you are the owner of a vehicle affected by this action.

- What is the issue?** On a small population of vehicles, the front wheel bearing bolts may have been incorrectly tightened by the supplier. If this condition is present in the vehicle, the bolts may loosen over time and adversely affect the driver's control over the vehicle, potentially causing a crash.
- What will we do?** To correct this defect, your authorized Volkswagen dealer will inspect and, if necessary, replace the affected front wheel bearing bolt(s). This work will take up to two hours to complete and will be performed for you free of charge. Please keep in mind that your dealer may need additional time for the preparation of the repair, as well as to accommodate their daily workshop schedule.
- What should you do?** Please contact your authorized Volkswagen dealer without delay to schedule this recall repair.
- Precautions you should take** If the front wheel bearing bolts have loosened, vehicle occupants may notice unusual noise coming from the front of the vehicle. If this should occur, customers are advised to contact an authorized Volkswagen dealer without delay and make arrangements to have the vehicle diagnosed/repared.
- Lease vehicles and address changes** If you are the lessor and registered owner of the vehicle identified in this letter, you shall forward this letter (and any subsequent notice, if applicable) to the lessee within ten (10) days of receipt. If you have changed your address or sold the vehicle identified in this letter, please fill out the enclosed prepaid Owner Reply Card and mail it to us so we can update our records.
- Can we assist you further?** If your authorized Volkswagen dealer fails or is unable to complete this work free of charge within a reasonable time, please contact Customer Relations, Monday through Friday from 8AM to 8PM EST by phone at 1-800-822-8987 or via our "Contact Us" page at [www.vw.ca](http://www.vw.ca).

We apologize for any inconvenience this matter may cause; however we are taking this action to help ensure your safety and continued satisfaction with your vehicle.

Sincerely,

Volkswagen Customer Protection

The repair information in this document is intended for use only by skilled technicians who have the proper tools, equipment and training to correctly and safely maintain your vehicle. These procedures are not intended to be attempted by "do-it-yourselfers," and you should not assume this document applies to your vehicle, or that your vehicle has the condition described. To determine whether this information applies, contact an authorized Volkswagen dealer. ©2021 Volkswagen Group of America, Inc. and Volkswagen Canada. All Rights Reserved.

## Repair Overview

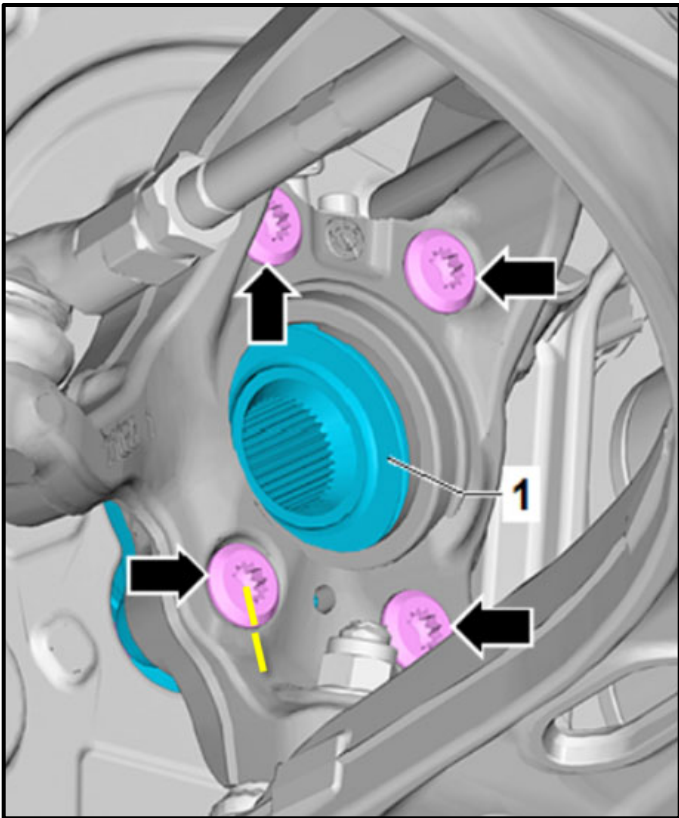

- Inspect left front and right front wheel bearing bolts <arrows>.
- Replace bolts, if necessary.

### NOTE

- These repair instructions may differ from the labor operations and labor times listed in ELSA.
- Damages resulting from improper repair or failure to follow these work instructions are the dealer's responsibility and are not eligible for reimbursement under this action.
- This procedure must be read in its entirety prior to performing the repair.
- Due to variations in vehicle equipment and options, the steps/illustrations in this work procedure may not identically match all affected vehicles.
- Diagnosis and repair of pre-existing conditions in the vehicle are not covered under this action.
- When working during extreme temperatures, it is recommended that the vehicle be allowed to acclimate inside the shop to avoid temperature-related component damage/breakage.



## Repair Instruction

### Section A - Check for Previous Repair

#### TIP

If Campaign Completion label is present, no further work is required.

Applicable criteria ID(s)	Campaign/Action Status
01 	Open 

**EXAMPLE**

Campaign/Action	Start	Designation
	2015-11-10	W-SERV_ACT -
	2018-12-13	RECALL -
	2017-05-16	A-RECALL -

**EXAMPLE**

- Enter the VIN in Elsa and proceed to the “Campaign/Action” screen.

#### TIP

On the date of repair, print this screen and keep a copy with the repair order.

- Confirm the Campaign/Action is open <arrow 1>. If the status is closed, no further work is required.
- Note the Applicable Criteria ID <arrow 2> for use in determining the correct work to be done and corresponding parts associated.

#### **CRITICAL REPAIR STEP**

 **STOP!** 

If multiple software update Campaign/Actions are open, they must be performed in order of the Start date <arrow 3>. The oldest should be performed first.

- **All Safety Recalls must be completed prior to completing this campaign.**
- **Proceed to Section B.**

## Section B – Repair Procedure

- Both front wheel bearings must be inspected.

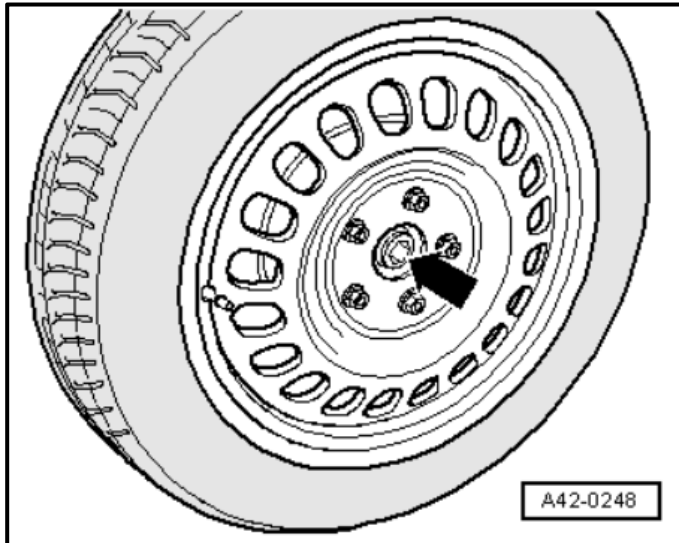

### Remove axle bolt:

- The front wheel center cap must be removed.
- With vehicle still resting on wheels, loosen the axle bolt <arrow> maximum 90°, otherwise, wheel bearing will be damaged.
- Lift the vehicle just enough so that the wheels are hanging free.
- Press the brake pedal. A second technician will be needed.
- Remove the axle bolt <arrow>.

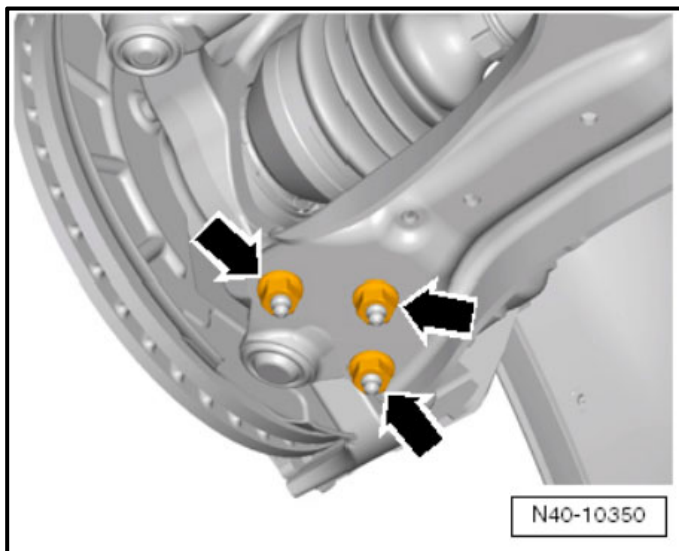

### Remove ball joint nuts:

- Remove the front wheel.
- Remove the three nuts <arrows>.
- Remove axle from wheel bearing and support the axle from falling.

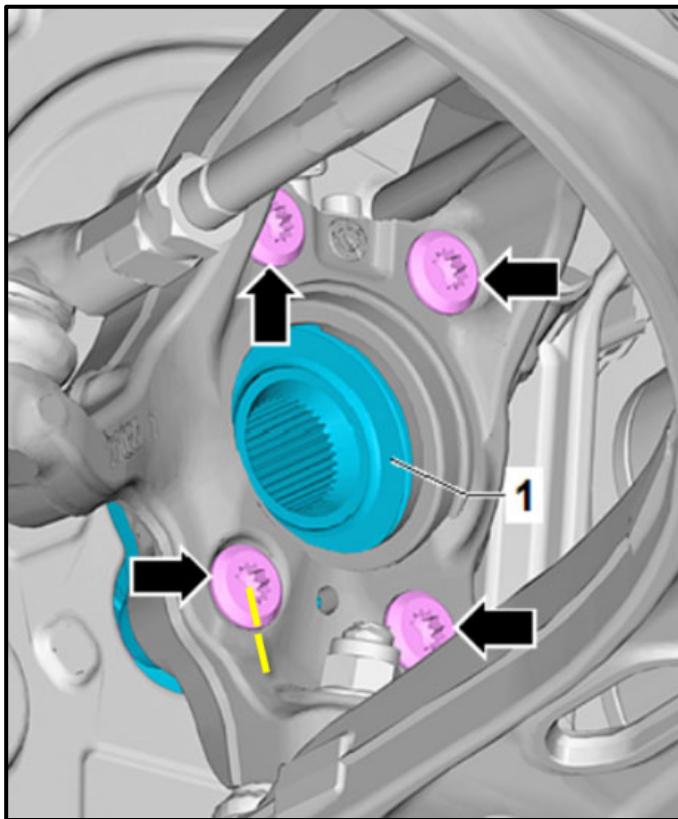

### Check wheel bearing bolt torque:

- All four wheel bearing bolts must be checked.
- Mark the position of each bolt.
- Set torque wrench to 140 Nm.
- Check the torque on each bolt.
- Reference the previously made marks and observe if the bolt moved.
- If the bolt did not move:
  - The bolt does not require replacement.
- If a bolt does move:
  - The bolt must be replaced.
  - Torque new bolt to 70 Nm + 90°.

Part Number	Part Description
WHT-004-835	Bolt - ATLAS
WHT-000-237-C	Bolt - PASSAT

- Move on to the next step once all bolts have been inspected or replaced.

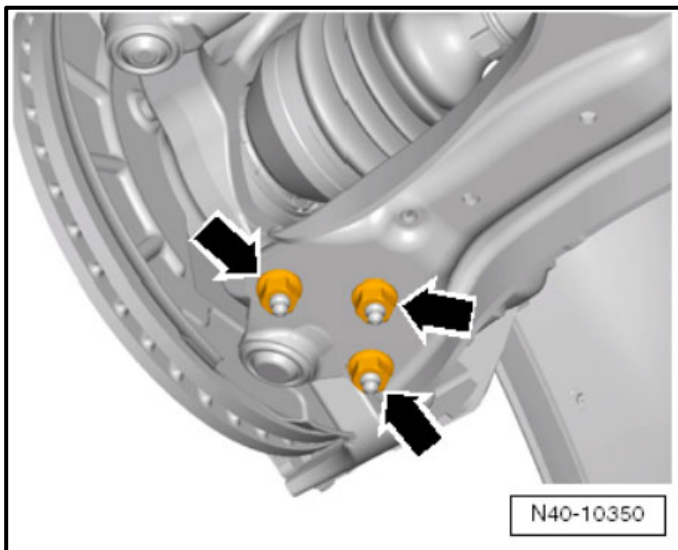

### Re-install ball joint to control arm:

- Insert axle into wheel bearing.
- Install ball joint into control arm.
- Install new nuts <arrows> and torque as follows:
  - Atlas - 40 Nm + 45°
  - Passat - 100 Nm

Part Number	Part Description
N -912-332-01	Nut - ATLAS
N -103-320-02	Nut - PASSAT

- Install front wheels and torque wheel bolts as follows:
  - Atlas - 120 Nm
  - Passat - 140 Nm

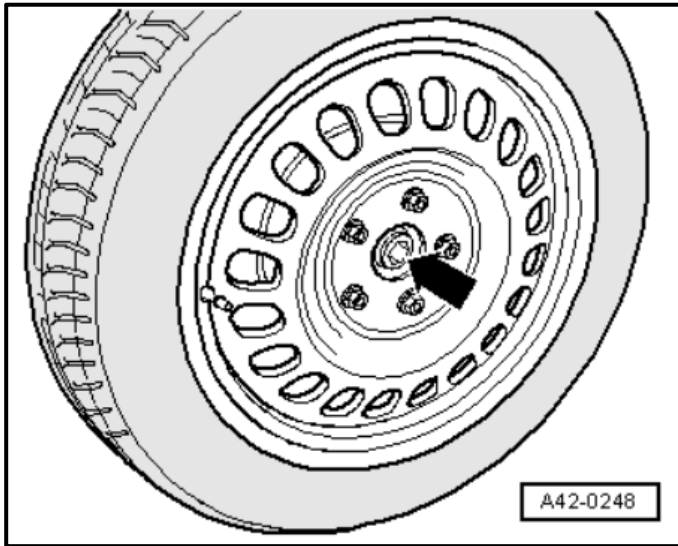

**Install axle bolt:**

- A new bolt must be used.

Part Number	Part Description
WHT-005-437-A	Axle bolt

- The wheels must not be touching the ground when tightening the drive axle. Otherwise, wheel bearing may be pre-damaged.
- Press the brake pedal. A second technician will be needed.
- Tighten the axle bolt to 200 Nm.
- Lower the vehicle onto its wheels.
- Turn the axle bolt an additional 90°.

**Proceed to Section C**

## Section C – Campaign Completion Label

### Install Campaign Completion Label

- Fill out and affix Campaign Completion Label, part number CAMP 010 000, next to the vehicle emission control information label.



#### TIP

Ensure Campaign Completion Label does not cover any existing label(s).

### Proceed to Section D

## Section D - Parts Return/Disposal

Properly store (retain), destroy or dispose of removed parts in accordance with all state/province and local requirements, unless otherwise indicated and/or requested through the Warranty Parts Portal (WPP) for U.S. and the Part Destruction and Core Disposition Report for Canada.