



RECALL CAMPAIGN BULLETIN

| | | |
|-----------------|------------|--------------------|
| Classification: | Reference: | Date: |
| BT21-016 | NTB21-087 | September 23, 2021 |

VOLUNTARY SAFETY RECALL CAMPAIGN 2022 PATHFINDER; 3RD ROW SEAT HEADREST REPLACEMENT

CAMPAIGN ID #: PC844
APPLIED VEHICLES: 2022 Pathfinder (R53)

**Check Service COMM or Dealer Business Systems (DBS)
National Service History to confirm campaign eligibility.**

INTRODUCTION

Nissan is conducting this voluntary safety recall campaign, on certain specific model year 2022 Pathfinder vehicles, to replace all the 3rd row seat headrests. This service will be performed at no charge to the customer for parts or labor.

IDENTIFICATION NUMBER

Nissan has assigned identification number PC844 to this campaign. This number must appear on all communication and documentation of any nature dealing with this campaign.

DEALER RESPONSIBILITY

It is the dealer's responsibility to check Service COMM or Dealer Business Systems (DBS) National Service History for the campaign status on each vehicle falling within the range of this voluntary safety recall which for any reason enters the service department. This includes vehicles purchased from private parties or presented by transient (tourist) owners and vehicles in a dealer's inventory. **Federal law requires that new vehicles in dealer inventory which are the subject of a safety recall must be corrected prior to sale. Failure to do so can result in civil penalties by the National Highway Traffic Safety Administration.** While federal law applies only to new vehicles, Nissan strongly encourages dealers to correct any used vehicles in their inventory before they are retailed.

Nissan Bulletins are intended for use by qualified technicians, not 'do-it-yourselfers'. Qualified technicians are properly trained individuals who have the equipment, tools, safety instruction, and know-how to do a job properly and safely. **NOTE:** If you believe that a described condition may apply to a particular vehicle, DO NOT assume that it does. See your Nissan dealer to determine if this applies to your vehicle.

SERVICE PROCEDURE

1. Press in the headrest hold buttons (A), and then remove the headrest (1) from the 3rd row seat (2) by pulling up.

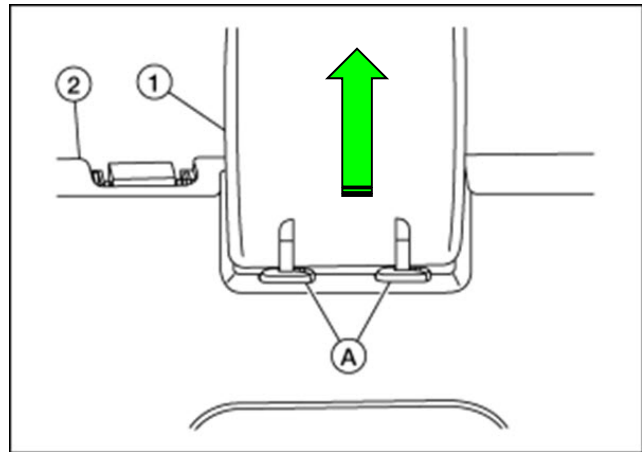

Figure 1

2. Repeat step 1 for the other two (2) headrests.
3. Install the three (3) new headrests in the reverse order of removal.
4. Using a suitable cutting tool, cut an "X" in the removed headrests, as shown in Figure 2, before discarding the headrest.



Figure 2

PARTS INFORMATION

| DESCRIPTION | PART NUMBER | QUANTITY |
|--|-------------|----------|
| HEADREST – 3 rd ROW SEAT (Center) | 86410 – (1) | 1 |
| HEADREST – 3 rd ROW SEAT (LH and RH) | 86480 – (1) | 2 |

(1) Use the VIN in EPC to determine the correct part number.

CLAIMS INFORMATION

Submit a “CM” line claim using the following claims coding:

| CAMPAIGN (“CM”) ID | DESCRIPTION | OP CODE | FRT |
|--------------------|--|---------|-----|
| PC844 | Replace All 3 rd Row Seat Headrests | PC8440 | 0.2 |

AMENDMENT HISTORY

| PUBLISHED DATE | REFERENCE | DESCRIPTION |
|--------------------|-----------|-----------------------------|
| September 23, 2021 | NTB21-087 | Original bulletin published |

