



David J. Johnson
Director
Service Engineering Operations
Ford Customer Service Division

Ford Motor Company
P. O. Box 1904
Dearborn, Michigan 48121

November 15, 2021

TO: All U.S. Ford and Lincoln Dealers

SUBJECT: **NEW VEHICLE DEMONSTRATION / DELIVERY HOLD - Compliance Recall 21C22**
Certain 2021 Model Year Mustang Mach-E Vehicles
Windshield Glass Reseal

REF: **Safety Recall 21S42 - Dated November 15, 2021**

AFFECTED VEHICLES

Vehicle	Model Year	Assembly Plant	Build Dates
Mustang Mach-E	2021	Cuautitlan	February 24, 2020 through June 18, 2021

Affected vehicles are identified in OASIS and FSA VIN Lists.

Automatic Closure: For VINs that have both 21C22 AND 21S42 open, both repairs must be completed at the same time. Claim by submitting for payment under 21S42, which will close both FSAs.

REASON FOR THIS COMPLIANCE RECALL

Some of the affected vehicles may not conform to the requirements specified by Federal Motor Vehicle Safety Standard (FMVSS) No. 212 Windshield Mounting, demonstrating possible inadequate urethane adhesion around significant portions of the glass. An improperly adhered windshield may not stay adequately retained in a crash, which may increase the risk of injury to an occupant. Affected vehicles could experience increased wind noise or water leaks.

SERVICE ACTION

Before demonstrating or delivering any new in-stock vehicles involved in this recall, dealers are to remove the windshield and improve the windshield urethane to body adhesion using the attached procedure. This service must be performed on all affected vehicles at no charge to the vehicle owner. **If the vehicle also has FSA 21S42, prior to scheduling customer for repairs, ensure the foam seal required for the panoramic roof glass is on site at your dealer.** LJ8Z-19B822-AA is expected to start shipping by the end of November 2021.

NOTE: Some of the vehicles in this program may also have 21S42 open. Check OASIS to see if FSA 21S42 is applicable. If so, refer to 21S42 technical instructions to perform both 21S42 and 21C22 as a combined repair procedure.

**** NOTE: For vehicles with both 21C22 and 21S42 open, refer to 21S42 dealer bulletin for claiming instructions. 21C22 labor operations will only pay on VINs with ONLY 21C22 open.**

OWNER NOTIFICATION MAILING SCHEDULE

Owner letters were mailed the week of October 25, 2021, informing them repair instructions and parts ordering information are anticipated to be available to dealers on November 15, 2021.

Dealers should repair any affected vehicles that arrive at their dealerships, whether or not the customer has received a letter.

PLEASE NOTE:

Federal law requires dealers to complete this recall service before a new vehicle is delivered to the buyer or lessee. Violation of this requirement by a dealer could result in a civil penalty of up to \$21,000 per vehicle. Correct all vehicles in your new vehicle inventory before delivery.

ATTACHMENTS

Attachment I: Administrative Information
Attachment II: Labor Allowances and Parts Ordering Information
Attachment III: Technical Information – Body Shop
Attachment IV: Technical Information – Glass Company
Attachment V: Vehicle Pick-up and Delivery Record
Owner Notification Letters

QUESTIONS & ASSISTANCE

For questions and assistance, contact the Special Service Support Center (SSSC) via the SSSC Web Contact Site. The SSSC Web Contact Site can be accessed through the Professional Technician System (PTS) website using the SSSC link listed at the bottom of the OASIS VIN report screen or listed under the SSSC tab.

Sincerely,

A handwritten signature in cursive script, appearing to read "D. Johnson".

David J. Johnson

**NEW VEHICLE DEMONSTRATION / DELIVERY HOLD -
Compliance Recall 21C22**
Certain 2021 Model Year Mustang Mach-E Vehicles
Windshield Glass Reseal

OASIS ACTIVATION

OASIS was activated on October 22, 2021.

FSA VIN LISTS ACTIVATION

FSA VIN Lists were available through <https://web.fsavinlists.dealerconnection.com> on October 22, 2021. Owner names and addresses were available on November 10, 2021.

NOTE: Your FSA VIN Lists may contain owner names and addresses obtained from motor vehicle registration records. The use of such motor vehicle registration data for any purpose other than in connection with this recall is a violation of law in several states, provinces, and countries. Accordingly, you must limit the use of this listing to the follow-up necessary to complete this recall.

SOLD VEHICLES

- Ford has not issued instructions to stop selling/delivering or driving used vehicles under this compliance recall. Owners should contact their dealer for an appointment to have their vehicles remedied as soon as practicable. Owners can continue to safely drive their vehicles.
- Immediately contact any of your affected customers whose vehicles are not on your VIN list but are identified in OASIS. Give the customer a copy of the Owner Notification Letter (when available) and schedule a service date.
- Correct other affected vehicles identified in OASIS which are brought to your dealership.
- Dealers are to prioritize repairs of customer vehicles over repairs of new and used vehicle inventory.

STOCK VEHICLES

- Correct all affected units in your new vehicle inventory before delivery.
- Use OASIS to identify any affected vehicles in your used vehicle inventory.

DEALER-OPERATED RENTAL VEHICLES

The Fixing America's Surface Transportation (FAST) Act law effective June 2016 prohibits a rental company from selling, renting or leasing vehicles subject to a safety or compliance recall. Please consult your legal counsel for legal advice.

TITLE BRANDED / SALVAGED VEHICLES

Affected title branded and salvaged vehicles are eligible for this recall.

OWNER REFUNDS

Refunds are not approved for this program.

RENTAL VEHICLES

Dealers are pre-approved for up to 2 days for a rental vehicle. Follow Extended Service Plan (ESP) guidelines for dollar amounts. Rentals will only be reimbursed for the day(s) the vehicle is at the dealership for part replacement. Prior approval for more than 2 rental day(s) is required from the SSSC. Contact the SSSC via the SSSC Web Contact Site for consideration and approval if appropriate.

**NEW VEHICLE DEMONSTRATION / DELIVERY HOLD -
Compliance Recall 21C22**

Certain 2021 Model Year Mustang Mach-E Vehicles
Windshield Glass Reseal

PICKUP AND DELIVERY

2021 Mustang Mach-E customers affected by this recall have the option of complimentary Vehicle Pickup & Delivery service (at participating dealers) with a rental for up to 2 days. Claim any additional rental days approved by the SSSC as instructed.

Dealers are authorized to claim unique services for completing this program, including:

- Dealers are authorized to claim one-half labor hour per repair for vehicle pick-up and delivery services.
- Dealers must retain a Vehicle Pick-up and Delivery Record with the repair order documentation. Refer to the Claims Preparation and Submission section and Attachment IV for details.

ADDITIONAL REPAIR (LABOR TIME AND/OR PARTS)

Additional repairs identified as necessary to complete the FSA should be managed as follows:

- For related damage and access time requirements, refer to the Warranty and Policy Manual / Section 6 – Ford & Lincoln Program Policies / General Information & Special Circumstances for FSA's / Related Damage.
- For vehicles within new vehicle bumper-to-bumper warranty coverage, no SSSC approval is required, although related damage must be on a separate repair line with the "Related Damage" radio button checked.
 - Ford vehicles – 3 years or 36,000 miles
- For vehicles outside new vehicle bumper-to-bumper warranty coverage, submit an Approval Request to the SSSC Web Contact Site prior to completing the repair.

CLAIMS PREPARATION AND SUBMISSION

**** NOTE: For vehicles with both 21C22 and 21S42 open, refer to 21S42 dealer bulletin for claiming instructions. 21C22 labor operations will only pay on VINs with ONLY 21C22 open.**

- **Claim Entry:** Enter claims using Dealer Management System (DMS) or One Warranty Solution (OWS) online.
 - When entering claims, select claim type 31: Field Service Action. The FSA number 21C22 is the sub code.
 - For additional claims preparation and submission information, refer to the Recall and Customer Satisfaction Program (CSP) Repairs in the OWS User Guide.
- **Related Damage/Additional labor and/or parts:** Must be claimed as Related Damage on a separate repair line from the FSA with same claim type and sub code as described in Claim Entry above.

IMPORTANT: Click the Related Damage Indicator radio button.

- **Rentals:** For rental vehicle claiming, follow Extended Service Plan (ESP) guidelines for dollar amounts. Enter the total amount of the rental expense under Miscellaneous Expense code RENTAL.

**NEW VEHICLE DEMONSTRATION / DELIVERY HOLD -
Compliance Recall 21C22**
Certain 2021 Model Year Mustang Mach-E Vehicles
Windshield Glass Reseal

CLAIMS PREPARATION AND SUBMISSION (continued)

- **Sublet Glass Removal/Installation:** Sublet repairs to remove and install the windshield can be claimed instead of 21C22C. Sublet documentation must be retained. Submit on the same line as the repair.
 - Program Code: 21C22
 - Misc. Expense: FSAOSL
 - Misc. Expense: Claim up to \$250
- **Provision for Locally Obtained Supplies:** Cleaning supplies, consumables, and either Dow® or Sika® brand automotive glass bonding materials. Submit on the same line as the repair.
 - Program Code: 21C22
 - Misc. Expense: OTHER
 - Misc. Expense: Claim up to \$100

**NEW VEHICLE DEMONSTRATION / DELIVERY HOLD -
Compliance Recall 21C22**
Certain 2021 Model Year Mustang Mach-E Vehicles
Windshield Glass Reseal

LABOR ALLOWANCES

****NOTE: For vehicles with both 21C22 and 21S42 open, refer to 21S42 dealer bulletin for claiming instructions. 21C22 labor operations will only pay on VINs that ONLY have 21C22 open.**

Description	Labor Operation	Labor Time
Prepare vehicle – Includes time to remove and install headliner, rear view mirror, wiper arms, and cowl.	21C22B	3.1 hours
Remove and install windshield using wire method, includes cleaning current windshield and applying primer to body and window	21C22C	1.0 Hours
Prepare windshield flange; protect vehicle, tape, scuff flange, clean flange, tape, and apply epoxy if needed	21C22D	1.2 Hours
IPMA camera alignment	21C22E	0.3 Hours
Clean Vehicle	MT21C22	Up to 0.5 Hours
Vehicle Pick-up and Delivery Allowance – NOTE: This allowance is for dealer-performed vehicle pick-up/delivery for dealership repairs only. Can only be claimed once, regardless of outstanding FSA's repaired.	21C22MM	0.5 Hours

PARTS REQUIREMENTS / ORDERING INFORMATION

Part Number	Description	Order Quantity	Claim Quantity
Consumables Required for all Vehicles			
Obtain Locally	Masking Tape	Claim as MISC OTHER	
	Glass Cleaner		
	Dow BETAPRIME 5504G / Sika Primer-207 or equivalent		
	SikaTack MACH 60 / SikaTack MACH 30 / Dow BETASEAL Express / Sika Tack ASAP Urethane Adhesive or equivalent		
	Roloc Disks or equivalent		
	Isopropyl Alcohol		
	Ford Approved Epoxy Based Primer		
Related Damage Only Part Numbers			
LJ8Z-5803100-A	Base Windshield	VIN Specific – Only if breaks during removal procedure.	
LJ8Z-5803100-H	High Series Windshield		

Order your parts through normal order processing channels. To guarantee the shortest delivery time, an emergency order for parts must be placed. **Note:** Less than 10% of the affected vehicle population is expected to require windshield replacement.

**NEW VEHICLE DEMONSTRATION / DELIVERY HOLD -
Compliance Recall 21C22**
Certain 2021 Model Year Mustang Mach-E Vehicles
Windshield Glass Reseal

DEALER PRICE

For latest prices, refer to DOES II.

PARTS RETENTION, RETURN, & SCRAPPING

Follow the provisions of the Warranty and Policy Manual, Section 1 - WARRANTY PARTS RETENTION AND RETURN POLICIES. If a replaced part receives a scrap disposition, the part must be scrapped in accordance with all applicable local, state and federal environmental protection and hazardous material regulations. Federal law prohibits selling motor vehicle parts or components that are under safety, compliance, or emissions recall.

EXCESS STOCK RETURN

Excess stock returned for credit must have been purchased from Ford Customer Service Division in accordance with Policy Procedure Bulletin 4000.

REPLACED FSA PARTS INSPECTION AND SIGN OFF

Effective March 1st 2021 all parts replaced as part of an FSA repair with a repair order open date of March 1st 2021 or later must be inspected and signed off on the repair order by a member of your dealers fixed operations management team or an employee the task has been delegated to. If the task is to be delegated to a non-management employee, the employee needs to be someone other than the technician who completed the repair and needs to understand the importance of completing this task consistently and accurately.

- All parts replaced as part of an FSA repair should be returned to the parts department following the Warranty Parts Retention and Return Policies.
- Inspect the replaced parts to verify the FSA repair was completed.
- If the FSA repair is found to be complete, the designated employee signs the repair order line or parts return stamp area (electronic or hand signed) for the FSA repair indicating the parts were inspected and validated to have been replaced.
- After the parts have been inspected, they should be handled based on the guidance in the parts status report in the Online Warranty System (Hold, Return, CORE, Scrap, etc.).
- This process is subject to review during warranty audits for FSA repairs with a repair order open date of March 1st 2021 or later. Any eligible FSA claims requiring parts replacement, found not to have been inspected and signed off during a warranty audit will be subject to chargeback and consideration for enrollment into the Dealer Incomplete Recall Repair Process.

Note: Other approvals (electronic or handwritten) for add-on repair lines, dealer owned vehicle repairs, and repeat repairs do not qualify as FSA parts inspection approvals. The post repair FSA parts inspection process (electronic or handwritten) is independent from other warranty approval requirements. The approval by the designated employee implies that the FSA parts were found to be replaced and must be able to be clearly identified on the Repair Order. If multiple FSA's require approval on a single Repair Order, each applicable occurrence will require individual post repair approval by the designated employee.

CERTAIN 2021 MODEL YEAR MUSTANG MACH-E VEHICLES — WINDSHIELD GLASS REATTACHMENT

SERVICE PROCEDURE – BODY SHOP INSTRUCTIONS

NOTE: These instructions are not intended to be followed from beginning to end. There are several locations where procedures must be completed by other groups before the procedure in these instructions can be resumed.

The instructions should be followed in this order.

1. Body Shop Part One – Prepare vehicle for repairs – Steps 1-6
2. Glass Company Part One – Remove windshield – Steps 1-11 as required.
3. Body Shop Part Two – Improve flange adhesion – Steps 7-14 as required.
4. Glass Company Part Two – Install windshield – Steps 12-19
5. Body Shop Part Three – Calibrate Image Processing Module A – Steps 15-17

BODY SHOP - PART ONE

1. Is 21S42 open on this VIN?

Yes – Do not proceed with these FSA instructions. Refer to 21S42 for technical and claiming instructions.

No – Proceed to step 2.

2. Remove the windshield wiper pivot arms. Please follow Workshop Manual (WSM) procedures in Section 501-16.
3. Remove the cowl panel grille. Please follow WSM procedures in Section 501-02.
4. Remove the headliner. Please follow WSM procedures in Section 501-05.
5. Remove the interior rear view mirror. Please follow WSM procedures in Section 501-09.
6. Disconnect the heated windshield electrical connector and tape the wires to the windshield to prevent damage. See Figure 1.





21506M

FIGURE 1

BODY SHOP - PART TWO

7. Cover/protect the body and interior of the vehicle with a one-time use, disposable drop plastic.
8. Using a scraper, cut through the urethane bead vertically down to the painted surface to create a starting point. Once reaching the painted surface, pry one side of the bead up with the scraper. Using fingers, work to peel the urethane off the windshield body flange.
9. In areas where the urethane peeled up cleanly, use 400-600 grit sandpaper or a fine Scotch-Brite pad to manually scuff clear coat lightly until it displays a white haze being sure to only abrade the flange. See Figure 2.

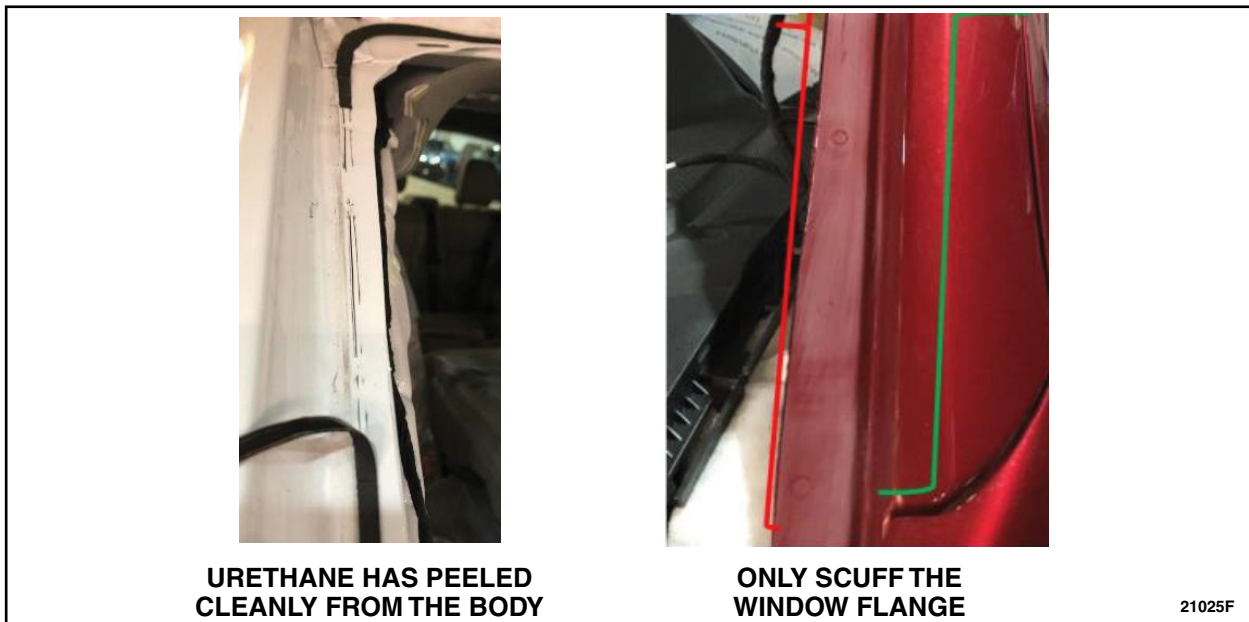

**URETHANE HAS PEELED
CLEANLY FROM THE BODY**

**ONLY SCUFF THE
WINDOW FLANGE**

21025F

FIGURE 2



10. In areas where the urethane did not peel up cleanly, use a Scotch-Brite 3M Roloc disk to remove all remaining urethane from flange while attempting to minimize abrasion to the painted surface. See Figure 3.



FIGURE 3

11. Clean off the entire windshield flange from all dirt and debris.
12. Using Isopropyl Alcohol and a lint-free cloth, clean off the flange surface. Allow one minute for the Isopropyl Alcohol to evaporate.
13. Apply tape to the edges of the windshield flange to protect the surface of the vehicle. See Figure 4.



FIGURE 4



14. Apply one coat of any Ford approved epoxy based repair primer to any spots where the roloc disk was used to grind off the urethane. Allow time for the primer to dry per the manufacturer's instructions. See Figure 5.



FIGURE 5

BODY SHOP - PART THREE

NOTE: Part Three may only be performed once the Glass Company repair procedures have been completed.

15. Remove the protective cover from the vehicle and clean off any dirt and debris.
16. Re-install all previously removed components by reversing steps 1-4.
17. After the windshield has been properly installed and the urethane has dried per the manufacturer's instructions, carry out the Image Processing Module A (IPMA) Camera alignment using a scan tool.



CERTAIN 2021 MODEL YEAR MUSTANG MACH-E VEHICLES — WINDSHIELD GLASS REATTACHMENT

SERVICE PROCEDURE – GLASS COMPANY INSTRUCTIONS

NOTE: These instructions are not intended to be followed from beginning to end. There are several locations where procedures must be completed by other groups before the procedure in these instructions can be resumed.

The instructions should be followed in this order.

1. Body Shop Part One – Prepare vehicle for repairs – Steps 1-6
2. Glass Company Part One – Remove windshield – Steps 1-11 as required.
3. Body Shop Part Two – Improve Flange adhesion – Steps 7-14 as required.
4. Glass Company Part Two – Install windshield – Steps 12-19
5. Body Shop Part Three – Calibrate Image Processing Module A – Steps 15-17

GLASS COMPANY - PART ONE

1. Apply tape to the perimeter of the windshield to protect from paint damage. See Figure 1.

NOTE: Tape off the roof panel near the centerline of the vehicle, where the roof extends forward. When using a piano wire to cut out the glass, the wire will roll over the class A paint in the roof area, once tension is applied to it. If using a nylon style string, this will not damage the paint.



FIGURE 1



2. Remove the windshield using a piano wire cut out tool. See Figure 2 where cutting fiber line was used.



FIGURE 2

3. Inspect the windshield for possible damage. Is there any damage to the windshield?

Yes – Replace the windshield. Proceed to Step 4.

No – Re-install the original windshield. Proceed to Step 12.

NOTE: Damage to the alignment pins does not require windshield replacement.

4. Use glass cleaner to clean the surface of the new windshield to be installed.

5. Release the tabs and remove the in-vehicle temperature and humidity sensor. See Figure 3.

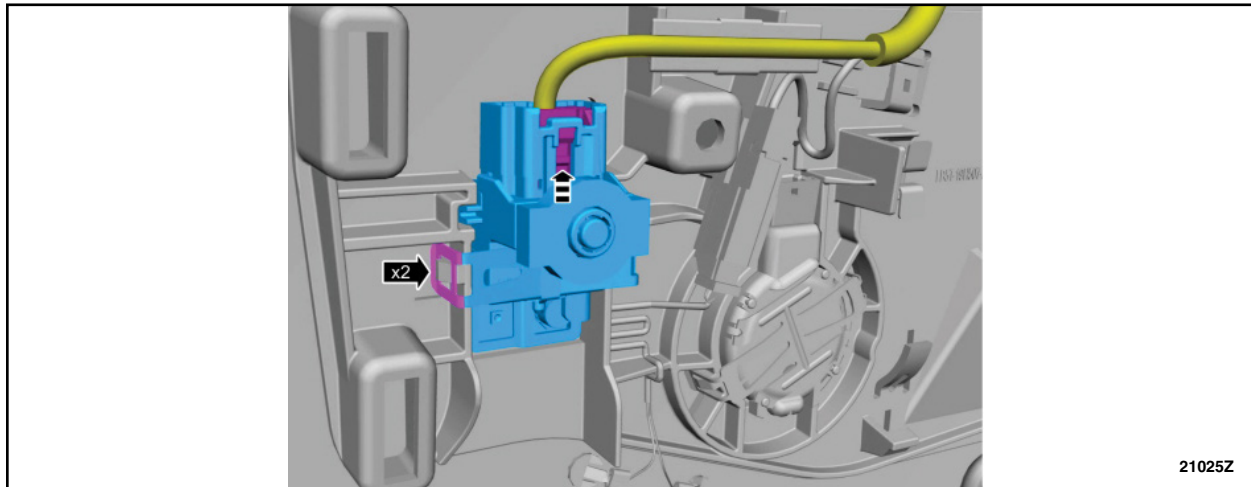

FIGURE 3



6. Re-install the temperature and humidity sensor into the new windshield.
7. Remove the Image Processing Module A (IPMA) Camera. See Figure 4.
 1. Release the tab.
 2. Release the tab and remove the IPMA camera.

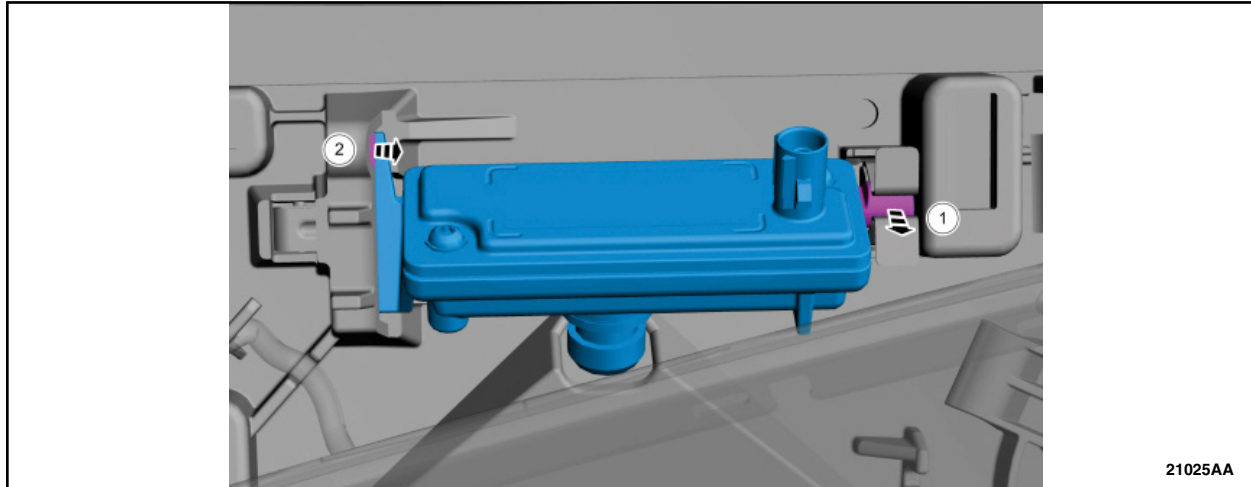

FIGURE 4

8. Re-install the IPMA camera into the new windshield.
9. Remove the rain sensor. See Figure 5.
 1. Release the retainers.
 2. Remove the rain sensor.

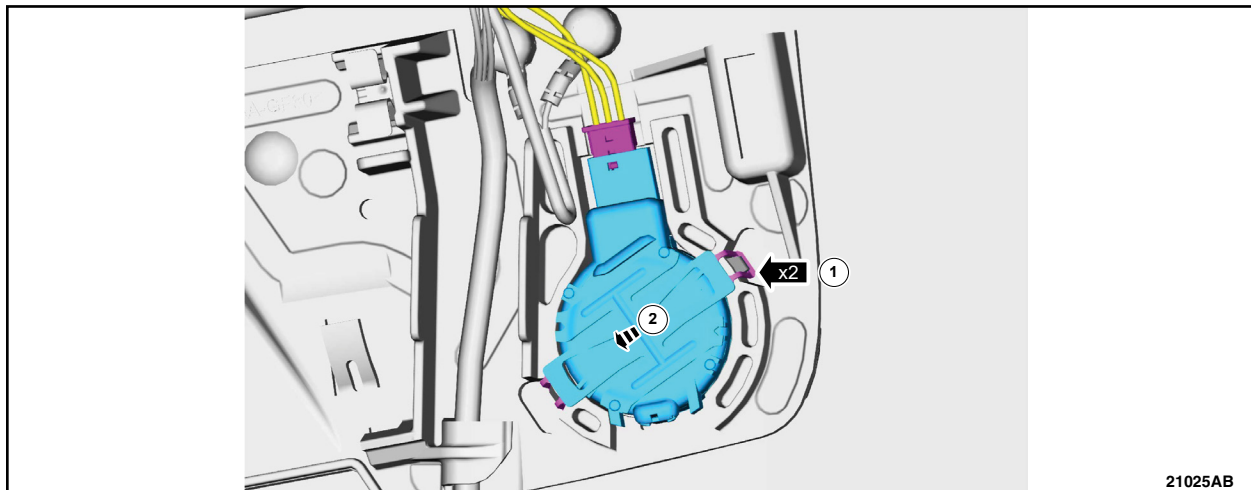

FIGURE 5



10. Inspect the rain sensor gel pack for damage. See Figure 6.

NOTE: If the rain sensor gel pack is damaged, install a new rain sensor.

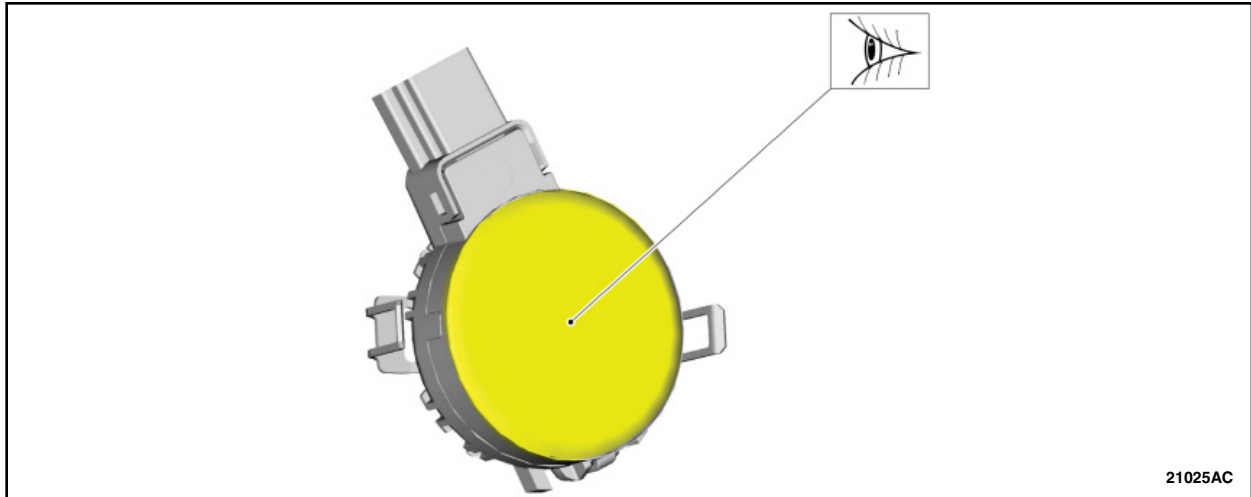

FIGURE 6

11. Re-install the rain sensor into the new windshield.



GLASS COMPANY - PART TWO

NOTE: Part Two may only be performed once the Body Shop repair procedures to the window flange have been completed.

12. Shave down the urethane on the original windshield until there is 1mm remaining. See Figure 7.



FIGURE 7

13. Apply two coats of urethane body flange primer according to the manufacturer's instructions to the entire windshield body flange at the urethane location. Additionally, apply two coats of window primer at any location where the clearcoat or paint layers have been damaged to provide environmental protection. Allow dry time between each coat applied.

Material: Sika® Aktivator PRO / Dow® BETAPRIME™ 5504G / Sika® Primer-207

14. Apply window primer according to the manufacturer's instructions to the new windshield. Allow dry time.

Material: Sika® Aktivator PRO / Dow® BETAPRIME™ 5504G / Sika® Primer-207

NOTE: This step only applies when replacing the windshield.

15. Apply window primer according to the manufacturer's instructions to the fixed glass anywhere the urethane adhesive was completely removed. Allow dry time.

Material: Sika® Aktivator PRO / Dow® BETAPRIME™ 5504G / Sika® Primer-207

NOTE: This step only applies when reusing the original windshield.



16. Cut the urethane adhesive applicator tip to specification. See Figure 8.

Material: Sika® SikaTack® MACH 60 / Sika® SikaTack® MACH 30 / Dow® BETASEAL™ Express
Material: Sika Tack ASAP Urethane Adhesive

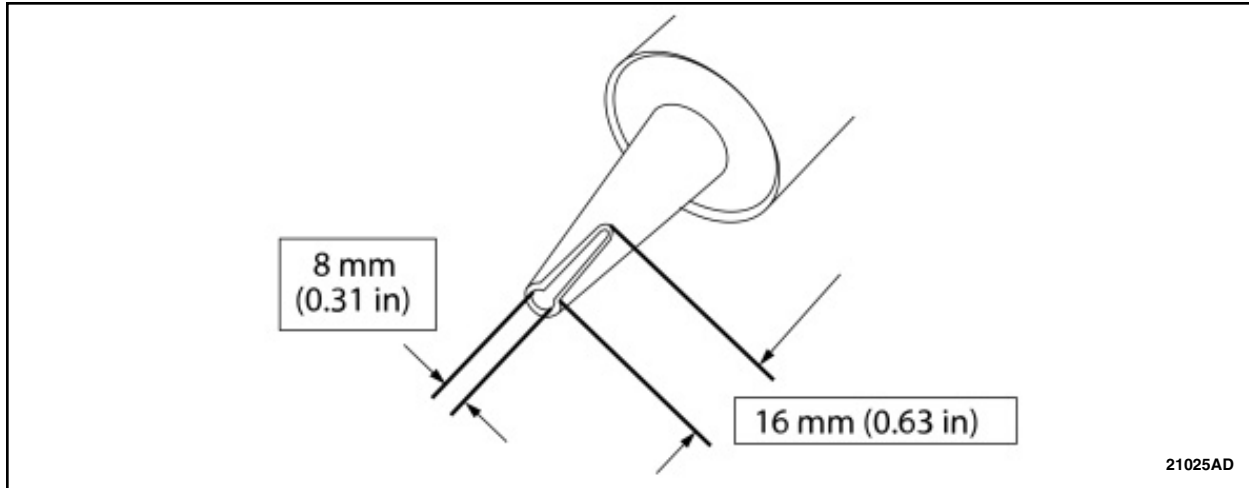

FIGURE 8

17. Apply a urethane adhesive bead. See Figure 9.

1. Start and end at the original overlap points to prevent air and water leaks.
2. Apply a urethane adhesive bead 14 mm (0.551 in) high and 8 mm (0.314 in) wide on top of the existing trimmed urethane adhesive bead on the pinch weld.
3. Make sure there are no gaps in the bead.

NOTICE: Make sure the urethane bead is uniform to prevent air and water leaks.

NOTE: The fixed glass must be installed within 10 minutes of applying the urethane adhesive.

NOTE: Use a power caulk gun that applies the urethane adhesive with less effort and a continuous bead.

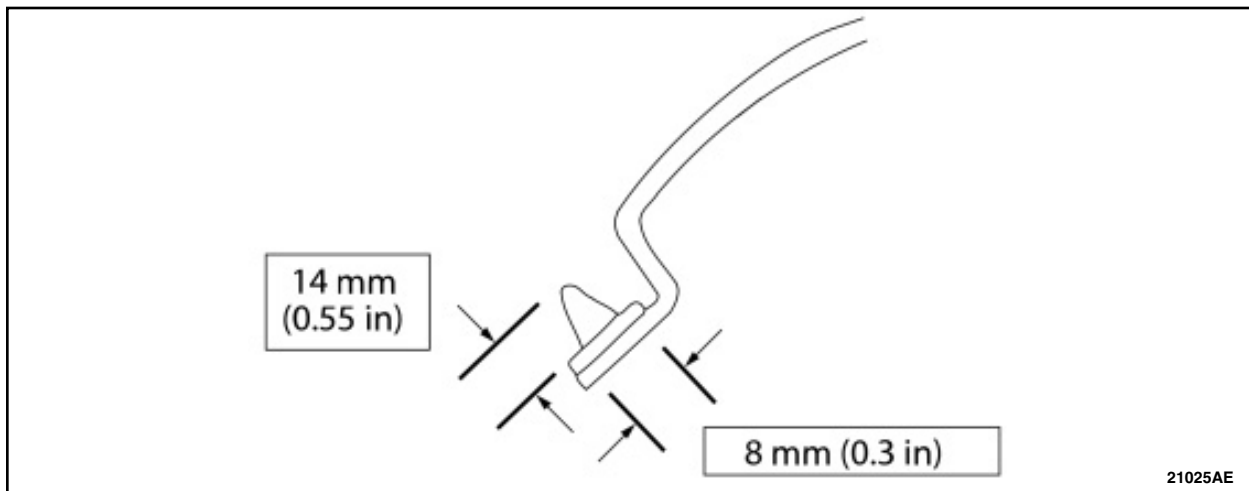

FIGURE 9



18. Open the vehicle windows to prevent the air pressure of closing doors from compromising the urethane adhesive bond.

NOTICE: The door windows must be left open during the adhesive curing time.

19. Install the fixed glass to the vehicle.

1. Install the fixed glass, pressing firmly by hand to ensure a good bond.
2. Secure the fixed glass in the correct position with tape until the urethane adhesive has cured.

⚠ WARNING: Do not drive vehicle until the urethane adhesive seal has cured. Follow urethane adhesive manufacturer's curing directions. Inadequate or incorrect curing of the urethane adhesive seal will adversely affect glass retention. Failure to follow these instructions may result in serious injury to vehicle occupant(s).



**NEW VEHICLE DEMONSTRATION / DELIVERY HOLD -
Compliance Recall 21C22**
Certain 2021 Model Year Mustang Mach-E Vehicles
Windshield Glass Reattachment

**MOBILE REPAIR / VEHICLE PICK-UP AND DELIVERY
RECORD**

VIN _____ received (check one):

- Mobile Repair
- Pick-up and/or delivery service

As outlined below for the 21C22 Field Service Action program.

Mobile Repair – Date: _____

OR

Pick-up – Date: _____

Delivery – Date: _____

Repair Order #

Repair Order Date

Service Manager Signature

Date