

# Safety Recall

## Code: 47R7



Audi

**REVISION**

**Subject** Brake Booster

**Release Date** October 23, 2021

**REVISION SUMMARY** Updated work instructions

**Affected Vehicles**

Country	Beginning Model Year	Ending Model Year	Vehicle	Vehicle Count
USA	2021	2021	E-TRON SPORTBACK QUATTRO	11
USA	2021	2021	E-TRON QUATTRO	27

Check Campaigns/Actions screen in Elsa on the day of repair to verify that a VIN qualifies for repair under this action. Elsa is the only valid campaign inquiry & verification source.

- ✓ Campaign status must show "open."
- ✓ If Elsa shows other open action(s), inform your customer so that the work can also be completed at the same time the vehicle is in the workshop for this campaign.

**Problem Description**

An electronic component in the brake servo which was not manufactured according to the specifications could corrode during the vehicle's service life and lead to functional issues with the brake servo causing a functional impairment of brake assist, ABS, electronic stability control and the speed indicator in the instrument cluster.

Full mechanical braking without brake boost is still possible but customers may experience increased brake pedal effort, hard brake pedal, an extended braking distance. In combination with the loss of ABS and ESC functionalities, this could increase the risk of a crash.

**Corrective Action**

Replace brake booster.

**Code Visibility**

On or about September 24, 2021, the campaign code was applied to affected vehicles.

**Owner Notification**

Owner notification took place in September 2021. Owner letter examples are included in this bulletin for your reference.

**Additional Information**

**Please alert everyone in your dealership about this action, including Sales, Service, Parts and Accounting personnel. Contact Warranty if you have any questions.**

**IMPORTANT REMINDER ON VEHICLES AFFECTED BY SAFETY & COMPLIANCE RECALLS**

**New Vehicles in Dealer Inventory: It is a violation of federal law for a dealer to deliver a new motor vehicle or any new or used item of motor vehicle equipment (including a tire) covered by this notification under a sale or lease until the defect or noncompliance is remedied. By law, dealers must correct, prior to delivery for sale or lease, any vehicle that fails to comply with an applicable Federal Motor Vehicle Safety Standard or that contains a defect relating to motor vehicle safety.**

**Pre-Owned Vehicles in Dealer Inventory: Dealers should not deliver any pre-owned vehicles in their inventory which are involved in a safety or compliance recall until the defect has been remedied.**

Dealers must ensure that every affected inventory vehicle has this campaign completed before delivery to consumers.

## Parts Information

<b>Parts Control Type:</b> <b>VIN to Order</b>	If parts are needed to support a vehicle repair: <ul style="list-style-type: none"> <li>US Dealers - use AVA</li> </ul>
---	---

<b>Parts Control Type:</b> <b>Free Order</b>	Parts will be managed by Free Order
---	-------------------------------------

<b>Initial Allocation:</b> <b>NO</b>	There will be no parts allocation. Please reference the Repair Projection Tool (below) to view your potential VIN population.
---	---

<b>Repair Projection Tool:</b> <b>(right click to open)</b>	
--	---

Criteria	Quantity	Part Number	P.O.C. Part Description	Ordering Method (see description above)
01	1	4KE-614-100-AF BEF	BRAKESERVO	VIN to Order
	1	4E0-260-749-C	WASHER	Free Order
	1	3D0-260-749-C	WASHER	Free Order
	1	4KE-614-306-C	FASTENING	Free Order
	1	4KE-614-303-A	ADAPTER	Free Order
	Up to 1 L	SEE ETKA/P.O.C.	DOT 4 BRAKE FLUID	Parts on Command

### IMPORTANT PARTS INFORMATION

#### Brake Fluid Ordering Information

- Any DOT 4 brake fluid part number listed in Parts on Command can be used.
- For claiming purposes, up to 2.00 units of B 0007501MDSP should be entered onto the SAGA claim.

### NOTE

The specified part numbers reflect the status at the start of this action. Interim updates made in ETKA can cause a listed part number to become unavailable. In this case, the new part number specified in ETKA should be used.

## Claim Entry Instructions

The labor times listed here may differ from the labor operations and labor times listed in ELSA.

After campaign has been completed, enter claim as soon as possible to help prevent work from being duplicated elsewhere. Attach the Elsa screen print showing action open on the day of repair to the repair order.

If customer refused campaign work:

- ✓ U.S. dealers: Submit the request through Audi Warranty Online under the Campaigns/Update option.

<b>Service Number</b>	47R7		
<b>Damage Code</b>	0099		
<b>Parts Vendor Code</b>	002		
<b>Claim Type</b>	Sold vehicle: 7 10 Unsold vehicle: 7 90		
<b>Causal Indicator</b>	Mark BRAKESERVO* as causal part		
<b>Vehicle Wash/Loaner</b>	Do not claim wash/loaner under this action		
<b>Criteria I.D.</b>	01		
	<b>LABOR</b>		
	<b>Labor Op</b>	<b>Time Units</b>	<b>Description</b>
	4770 55 99	300	Replace brake pressure unit
	2706 89 50	10	Connect battery charger
	0150 00 00	Time stated on diagnostic protocol	GFF Operations
	<b>PARTS</b>		
	<b>Quantity</b>	<b>Part Number</b>	<b>Description</b>
	1.00	4KE614100AFBEF	BRAKESERVO*
	1.00	4E0260749C	SEAL RING
	1.00	3D0260749C	SEAL RING
	1.00	4KE614306C	FASTENING
	1.00	4KE614303A	ADAPTER
	Up to 2.00	B 0007501MDSP	Brake Fluid

## Customer Letter Example (USA)

<MONTH YEAR>

<CUSTOMER NAME>

<CUSTOMER ADDRESS>

<CUSTOMER CITY STATE ZIPCODE>

**This notice applies to your vehicle:** <MODEL YEAR> <BRAND> <CARLINE>, <VIN>

**NHTSA:** 21V707

**Subject: Safety Recall 47R7 – Brake Booster**

Dear Audi Owner,

This notice is sent to you in accordance with the National Traffic and Motor Vehicle Safety Act. Audi has decided that a defect, which relates to motor vehicle safety, exists in certain 2021 model year Audi vehicles. Our records show that you are the owner of a vehicle affected by this action.

- What is the issue?** An electronic component in the brake servo which was not manufactured according to the specifications could corrode during the vehicle's service life and lead to functional issues with the brake servo causing a functional impairment of brake assist, ABS, electronic stability control and the speed indicator in the instrument cluster.
- Full mechanical braking without brake boost is still possible but customers may experience increased brake pedal effort, hard brake pedal, an extended braking distance. In combination with the loss of ABS and ESC functionalities, this could increase the risk of a crash.
- What will we do?** To correct this defect, your authorized Audi dealer will replace the brake booster. This work will take about four hours to complete and will be performed for you free of charge. Please keep in mind that your dealer may need additional time for the preparation of the repair, as well as to accommodate their daily workshop schedule.
- What should you do?** Please contact your authorized Audi dealer without delay to schedule this recall repair. For your convenience, you can also visit [www.audiusa.com](http://www.audiusa.com) and click on the "Find a Dealer" link to locate a dealer near you and schedule this service.
- Lease vehicles and address changes** If you are the lessor and registered owner of the vehicle identified in this action, the law requires you to forward this letter immediately via first-class mail to the lessee within ten (10) days of receipt. If you have changed your address or sold the vehicle, please fill out the enclosed prepaid Owner Reply card and mail it to us so we can update our records.
- Can we assist you further?** If your authorized Audi dealer fails or is unable to complete this work free of charge within a reasonable time, please contact Audi Customer Experience at 1-800-253-2834 or via our "Contact Us" page at [www.audiusa.com](http://www.audiusa.com).
- Checking your vehicle for open Recalls and Service Campaigns** To check your vehicle's eligibility for repair under this or any other recall/service campaign, please visit the **Recall/Service Campaign Lookup** tool at [www.audiusa.com](http://www.audiusa.com) and enter your Vehicle Identification Number (VIN).

If you still cannot obtain satisfaction, you may file a complaint with: The Administrator, National Highway Traffic Safety Administration, 1200 New Jersey Avenue, SE., Washington, DC 20590; or call the toll-free Vehicle Safety Hotline at 1-888-327-4236 (TTY: 1-800-424-9153); or go to <http://www.safercar.gov>.

We apologize for any inconvenience this matter may cause; however we are taking this action to help ensure your safety and continued satisfaction with your vehicle.

Sincerely,

Audi Customer Protection

## Repair Overview

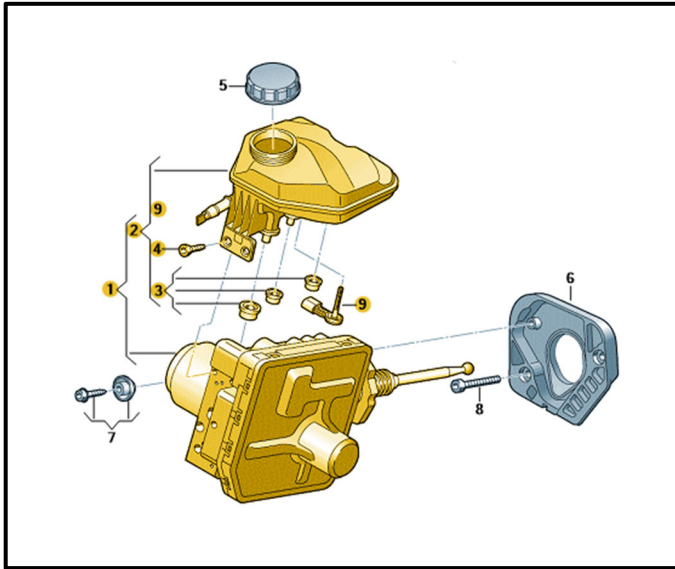

- Replace Brake Pressure Unit.

### ! NOTE

- These repair instructions may differ from the labor operations and labor times listed in ELSA.
- Damages resulting from improper repair or failure to follow these work instructions are the dealer's responsibility and are not eligible for reimbursement under this action.
- This procedure must be read in its entirety prior to performing the repair.
- Due to variations in vehicle equipment and options, the steps/illustrations in this work procedure may not identically match all affected vehicles.
- Diagnosis and repair of pre-existing conditions in the vehicle are not covered under this action.
- When working during extreme temperatures, it is recommended that the vehicle be allowed to acclimate inside the shop to avoid temperature-related component damage/breakage.

## Required Tools

 <p>Puller - Windshield Wiper -T40394-</p>	 <p>R1234yf Air Conditioning Service Unit -ROB1234YFX- or -VAS581005-</p>
 <p>Brake Filling and Bleeding Equipment -VAS6860- (or equivalent)</p>	 <p>Brake Bleeding Tool Set -VAS6564- (or equivalent)</p>
 <p>Warning Sign - High Voltage -VAS6649-</p>	 <p>Warning Sign - "Do Not Switch On" -VAS6650A-</p>
 <p>Padlock -T40262/1- (from Service Disconnect Lock -T40262-)</p>	 <p>Brake Servo Release Tool -T40136-</p>
 <p>Engine Bung Set -VAS6122- (or equivalent)</p>	

## Repair Instruction

### Section A - Check for Previous Repair

Applicable criteria ID(s)	Campaign/Action Status
01 ← 2	Open ← 1

**EXAMPLE**

Campaign/Action	Start	Designation
← 3	2015-11-10	W-SERV_ACT -
	2018-12-13	RECALL -
	2017-05-16	A-RECALL -

**EXAMPLE**

- Enter the VIN in Elsa and proceed to the “Campaign/Action” screen.

#### TIP

On the date of repair, print this screen and keep a copy with the repair order.

- Confirm the Campaign/Action is open <arrow 1>. If the status is closed, no further work is required.
- Note the Applicable Criteria ID <arrow 2> for use in determining the correct work to be done and corresponding parts associated.

#### CRITICAL REPAIR STEP

 **STOP!** 

If multiple software update Campaign/Actions are open, they must be performed in order of the Start date <arrow 3>. The oldest should be performed first.

- **All Safety Recalls must be completed prior to completing this campaign.**
- **Proceed to Section B.**

## Safety Precautions When Working NEAR the High-voltage System (additional information is also available in the ELSA Repair Manual)

### DANGER

#### **Extremely dangerous due to high voltage.**

- The voltage levels in the high-voltage system constitute a safety hazard. Danger of severe or fatal injuries from electric shock if high-voltage components or high-voltage wiring are damaged.
- Carry out a visual check of high-voltage components and high-voltage wiring.
- Never use cutting/forming tools or other sharp-edged implements.
- Never perform work using welding, brazing, thermal bonding or hot air in the area of high-voltage components and high-voltage cables.



## Section B – Repair Procedure

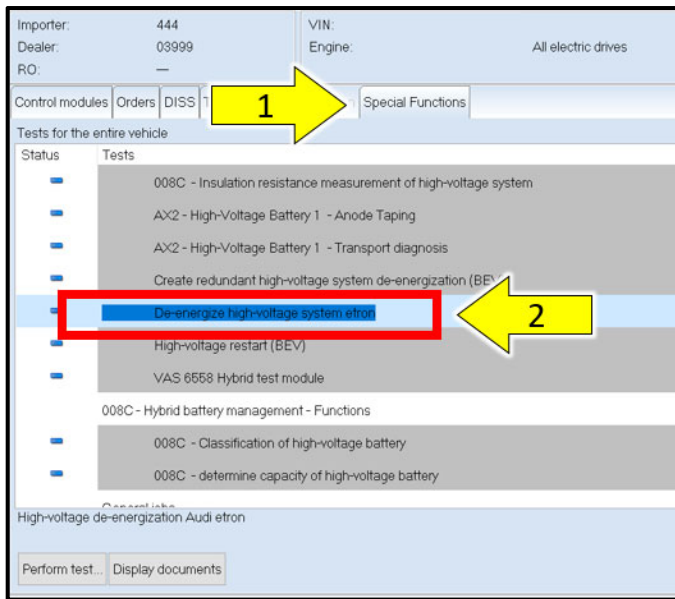

### De-energize HV system:

- Follow the GFF test plan for disabling the high voltage system:
  - Perform a diagnostic scan of the vehicle.
  - Select the “Special Functions” tab <1>.
  - Perform the “De-energize high-voltage system e-tron” test plan <2>.
- Pay close attention to the test plan instructions when de-energizing the high-voltage system.
- The test plan will guide you through all of the de-energization steps. **READ EACH SCREEN CAREFULLY!!**
- **Refer to the Function Description tabs if necessary.**
- **Save the diagnostic session.**

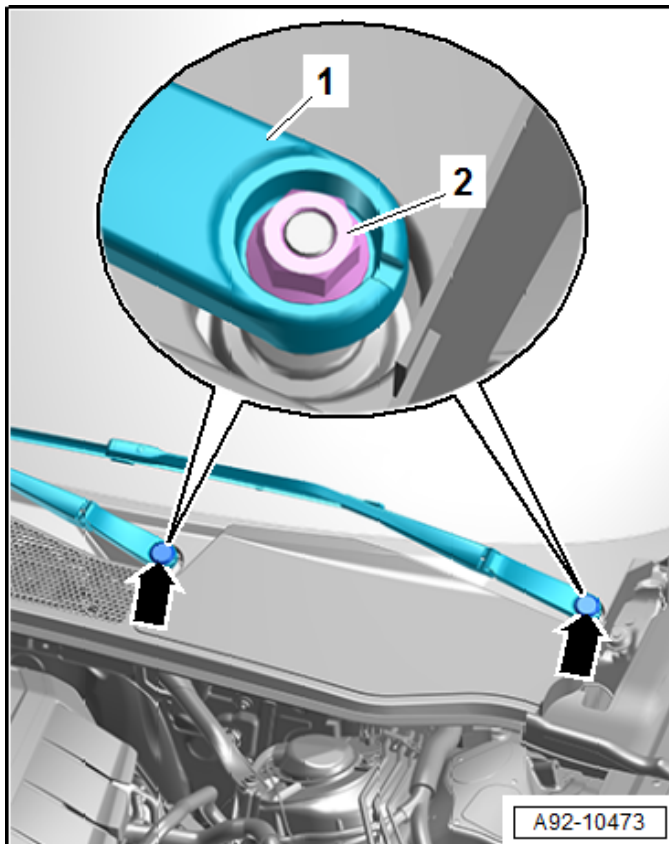

### Remove windshield wiper arms:

- Mark the current position of the wiper arms with masking tape, for example.
- Pry off the caps <arrows>.
- Remove nuts <2>.



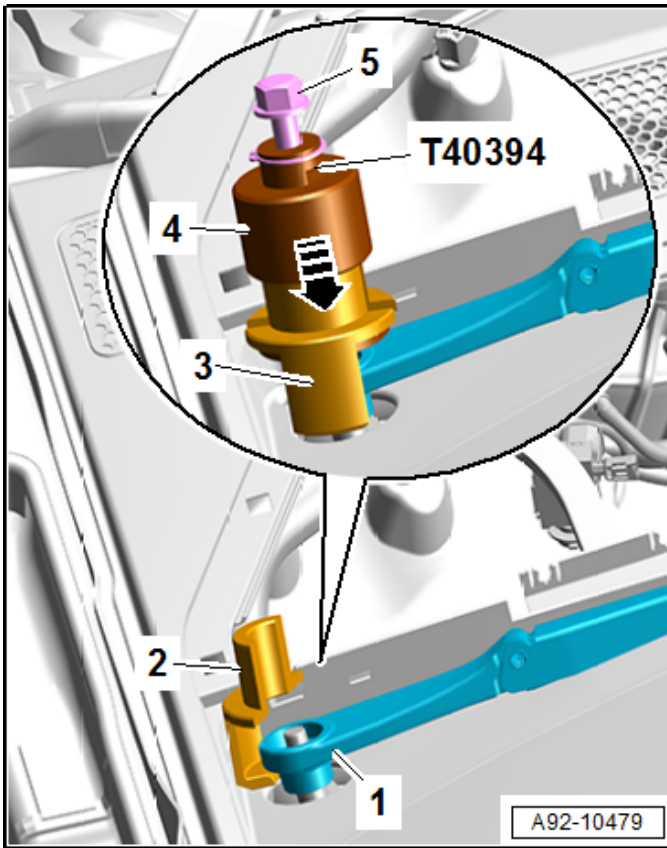

- Position the hook <2> on the windshield wiper arm <1>.
- Position the -T40394- on the opposite side of the windshield wiper arm and latch the pivoting hook <3>.
- Push the locking ring <4> downward in direction of <arrow>.
- Turn the bolt <5> clockwise until the windshield wiper arm is removed from the windshield wiper axle.
- Remove the windshield wiper arms.

**NOTE**

If vehicle is equipped with wipers arms integrated with washer nozzles, the washer fluid hoses will have to be freed up. See ELSA Repair Manual, group 92 for more information if needed.

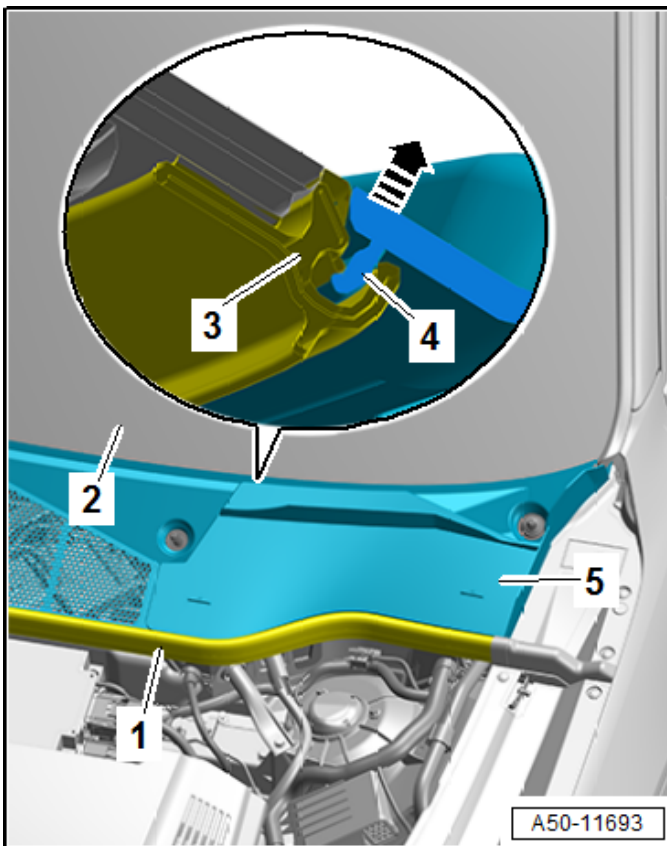

**Remove plenum chamber cover:**

- Remove the seal <1>.
- Coat the transition between the windshield <2> and the plenum chamber cover <5> with soapy water.
- Starting at the glass edge, carefully remove the plenum chamber cover from the windshield retainer by lifting it vertically upward.
- Remove the plenum chamber cover <5> by carefully removing the plenum chamber cover tab <4> in the direction of <arrow> from the windshield mount <3>.

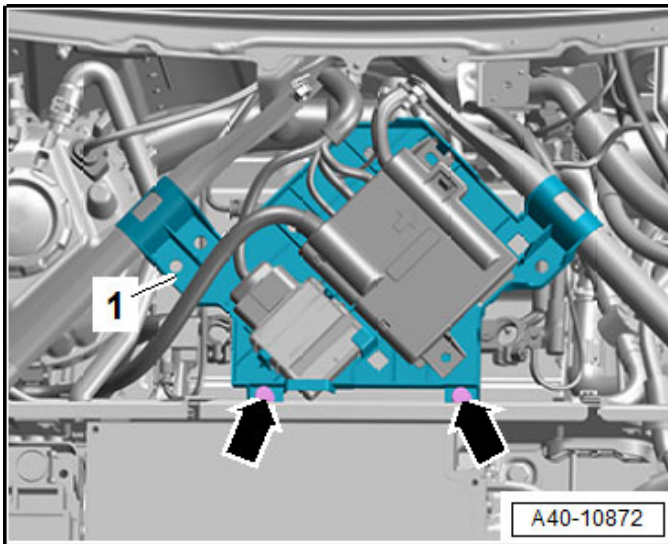

### Remove left (driver side) tower brace:

- Remove the expanding clips <arrows> and remove the bracket <1> for Windshield Washer Pump Control Module -J1100-.

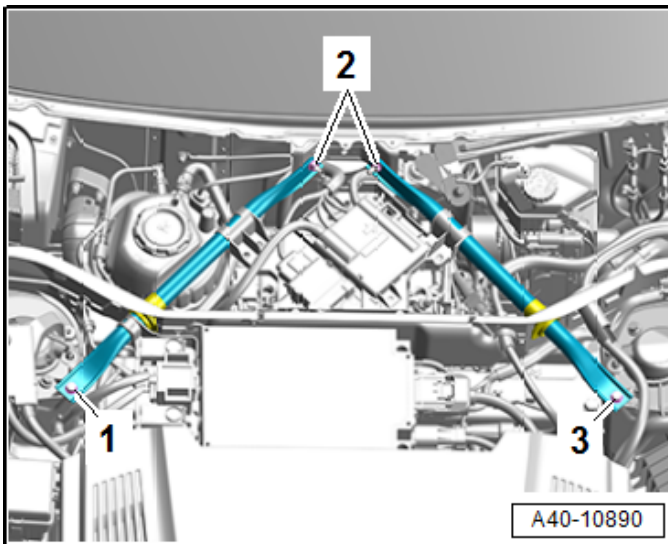

- Remove the bolt <3> and nut <2> (left side) and remove the left (driver side) tower brace.

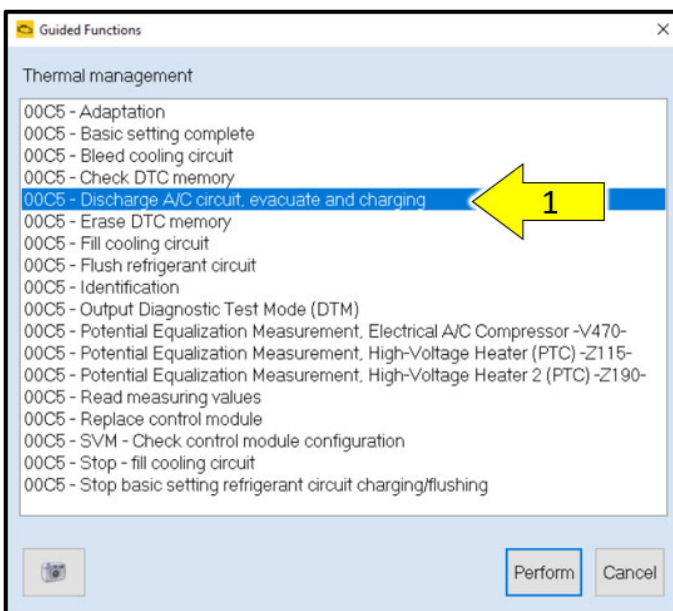

### Open refrigerant system valves:

- Follow the test plan for opening the refrigerant system valves:
  - Open the Guided Functions menu for Thermal Management by right clicking on Address 00C5.
  - Perform the test “00C5 - Discharge A/C circuit, evacuate and charging” <1>.



### Evacuate A/C system:

- Perform the procedure as described in the A/C Service Station Owner's Manual.
- The quantity of refrigerant oil in the A/C Service Station is checked and if necessary corrected.
- The refrigerant quantity in the A/C Service Station is checked and if necessary corrected.
- For more information, refer to the Repair Manual:
  - ELSA Repair Manual: *Repair manual > Heating, Ventilation & Air Conditioning > Refrigerant R1234yf Servicing*

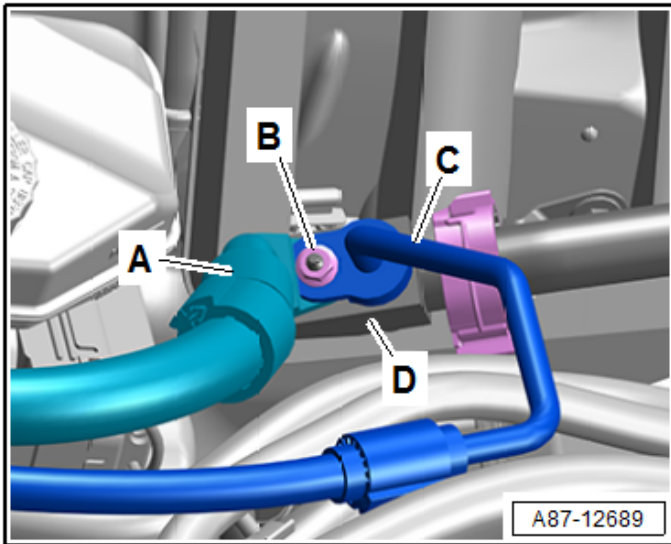

### Unbolt refrigerant lines:

- Remove nut <B>.
- Remove lines <A> and <C>.



- Immediately seal all openings with seals from -6122- kit.

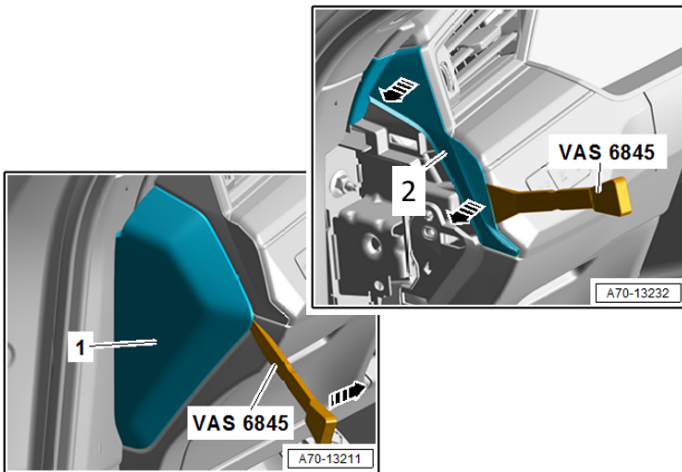

### Remove instrument panel side covers:

- Carefully pry off instrument panel side covers <1> and <2> using the VAS6945-.

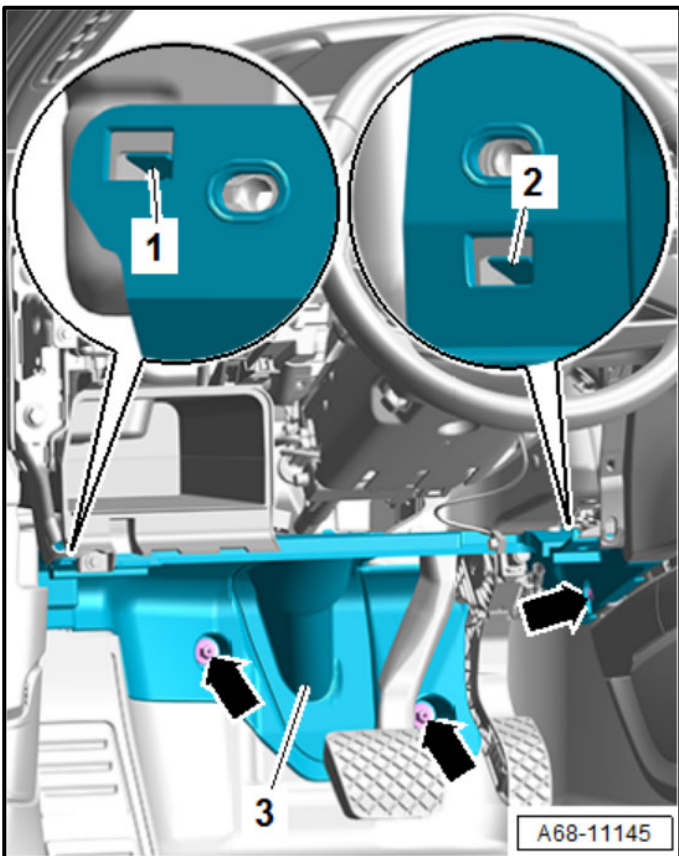

### Remove driver side footwell cover:

- Remove two nuts and one bolt <arrows>.
- Release the catches <1 and 2> using a flat-head screwdriver and remove the footwell cover on the driver side <3> downward.
- Disengage the diagnostic connection on the footwell cover.
- Equipped on some models: disconnect the connectors for the footwell lamp, parking aid speaker and the emergency call speaker.
- Remove the footwell cover on the driver side toward the rear.



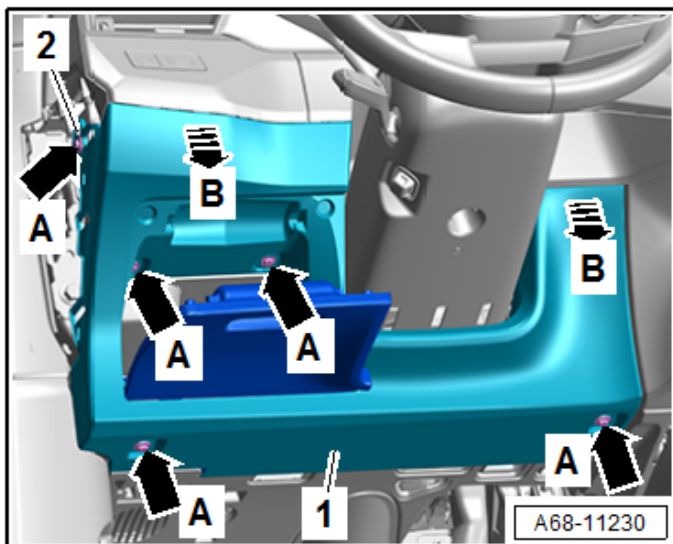

### Remove driver side instrument panel cover:

- Open the storage compartment.
- Remove the bolts <A arrows>.
- Disengage the instrument panel cover on the side at the pin <2>.
- Unclip the driver side instrument panel cover <1> by hand or with the -3409- from the instrument panel <B arrows>.
- Remove the driver side instrument panel cover.

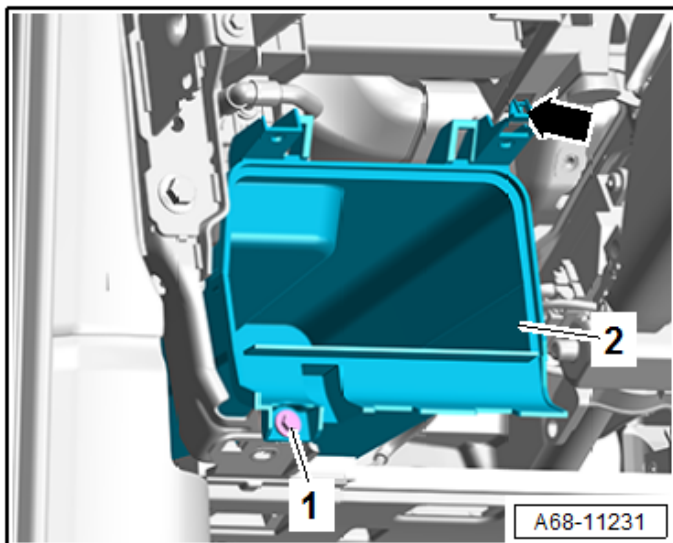

### Remove storage compartment:

- Remove the bolt <1>.
- Release the catch <arrow> using a flat-head screwdriver and disengage storage compartment <2> downward.
- Remove the storage compartment toward the rear.

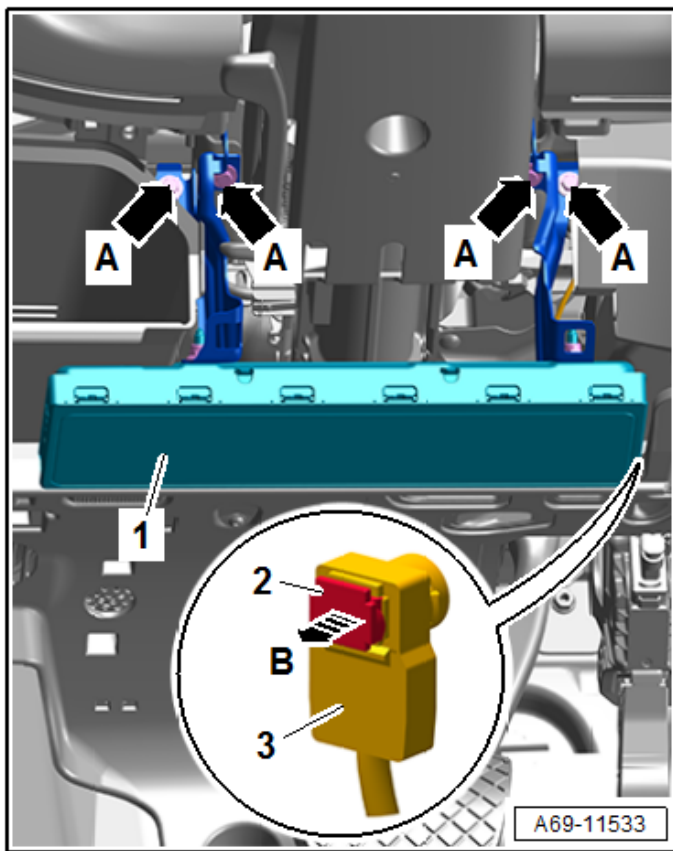

### Remove knee airbag:

- Move the steering wheel as far up and backward as possible to be able to use the entire steering column adjustment range.
- Remove the bolts <A arrows>.
- Disengage the knee airbag <1> with the brackets on the crossmember.
- Carefully remove the knee airbag with the brackets, until the connector <3> can be disconnected.
- Release the connector lock <2> with a small flat-head screwdriver <arrow B>.
- Disconnect the connector from the knee airbag igniter.

### ⚠ CAUTION

**Pyrotechnical components can deploy unintentionally.**

**Risk of injury.**

Discharge the static electricity: quickly touch the door striker.

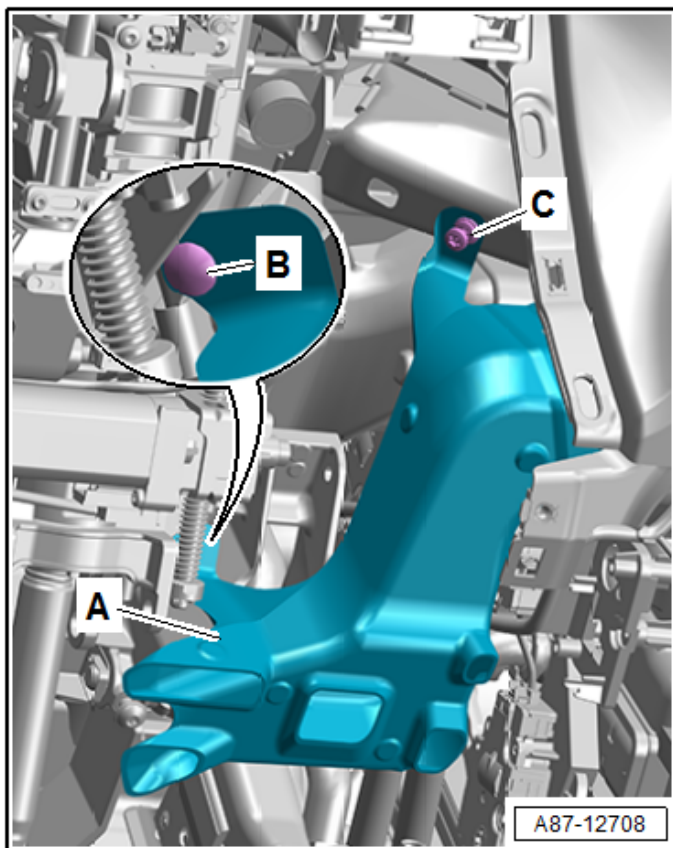

### Remove footwell vent:

- Remove the expanding rivets <B and C>.
- Remove the left footwell vent <A> from the heater and A/C unit.

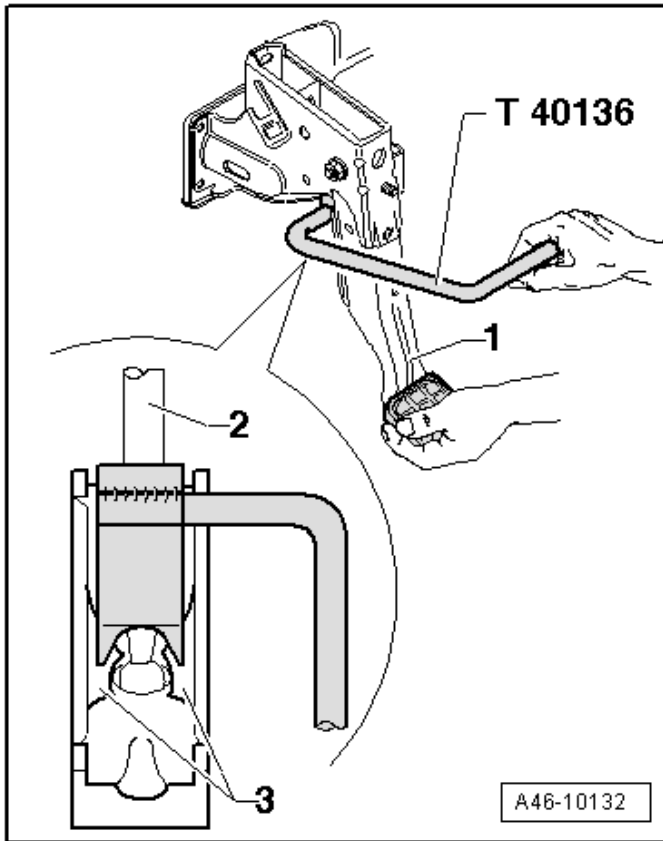

**Disconnect brake pedal from brake pressure unit:**

- Press and hold the brake pedal in the direction of the brake pressure unit.
- Insert the Brake Servo Release Tool -T40136- and pull in the direction of the driver seat while counterholding at the brake pedal <1> so that it does not move backward. While doing so, the mount retaining tabs <3> will be pushed out of the pushrod ball head <2>.
- Pull the Brake Servo Release Tool -T40136- and the brake pedal together toward the driver seat. This will pull the brake pedal off the pushrod ball head.



### Removing brake pressure unit:

- To prevent spillage, drain the brake fluid reservoir using the -VAS6860-.
- Disconnect the connectors <4>.
- To prevent brake fluid from escaping, place enough lint-free cloths in the area under the brake pressure unit.

#### **⚠ WARNING**

**Leaking brake fluid increases the risk of injury.  
Risk of skin irritation and injury.**

Wear safety gloves.

#### **⚠ CAUTION**

**Risk of destroying the brake lines by bending.**

Never change the shape of the brake lines.

A damaged or bent brake line must be replaced.

#### **! NOTE**

Brake fluid reservoir shown removed. The brake fluid reservoir does not require removal when replacing the brake pressure unit.

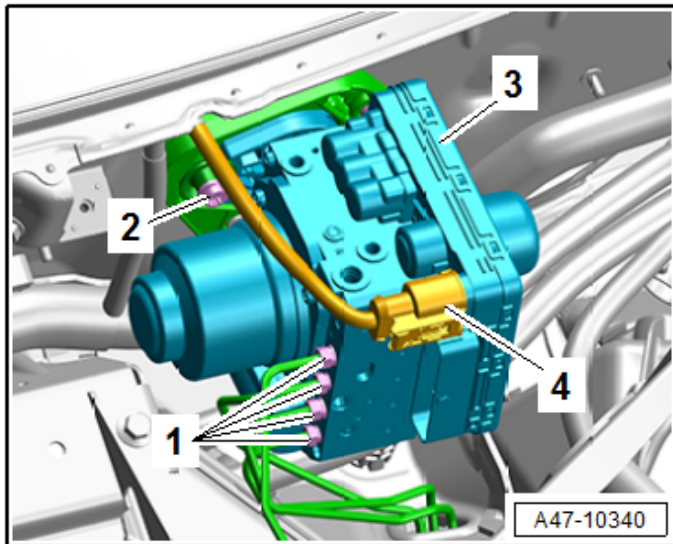

- Remove the union bolts <1> for the brake lines, then remove the brake lines from the brake pressure unit and move them slightly to the side.
- Immediately seal the open brake line connection points.
- Remove the bolt <2>.
- Carefully hold the A/C lines and brakes lines to the side with the aid of a second technician.
- Carefully remove the brake pressure unit <3> from the plenum chamber:
  - Rotate brake pressure unit slightly and remove diagonally upward toward the passenger side.

### Install new adapter:

- Install new adapter <1>.

Part Number	Part Description
4KE-614-303-A	Adapter

- Torque bolts <A> to 24 Nm.

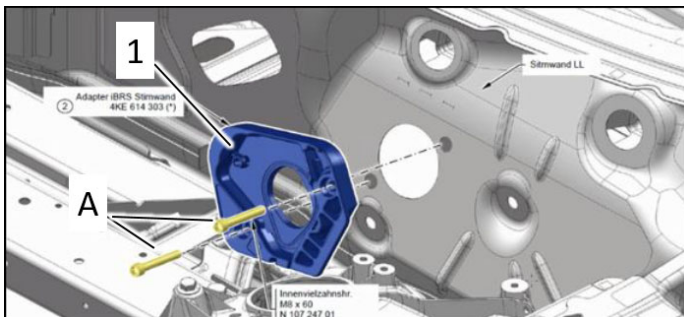

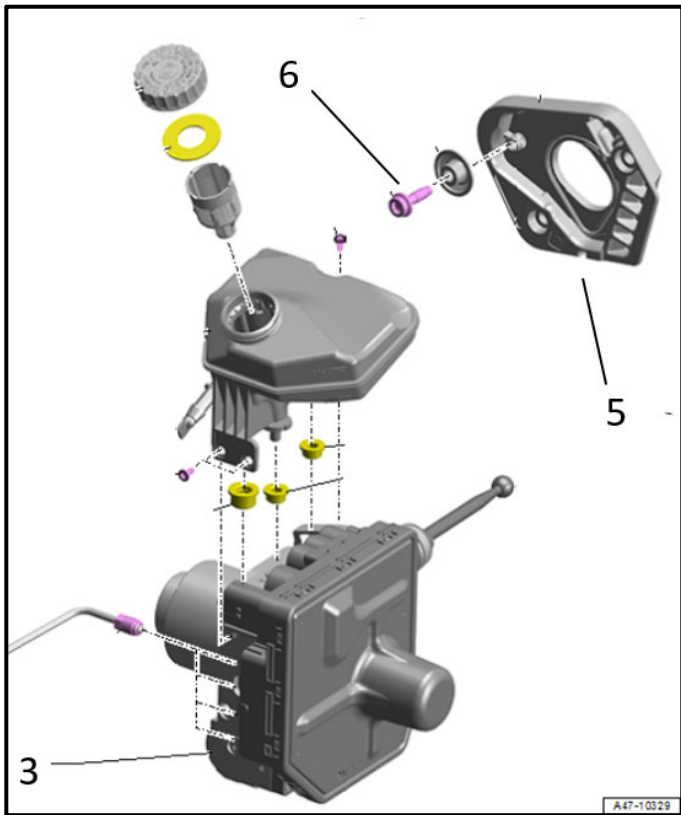

**Install the new brake pressure unit in the reverse order of removal:**

Part Number	Part Description
4KE-614-100-AF BEF	Brake Pressure Unit

- Clean all sealing surfaces before installing the brake pressure unit.
- Thoroughly clean the rest of the dripping brake fluid off of the plenum chamber.
- Insert the brake pressure unit carefully.

<b>i</b> TIP
Before securing the brake pressure unit, make sure the push rod is aligned with the brake pedal mounting tabs.

- The brake pressure unit surface on the bulkhead must not be damaged or deformed.
- Replace attaching element <6> and torque to 24 Nm.

Part Number	Part Description
4KE-614-306-C	Attachment Element

- Insert the brake lines into the brake pressure unit by hand and torque to 14 Nm.

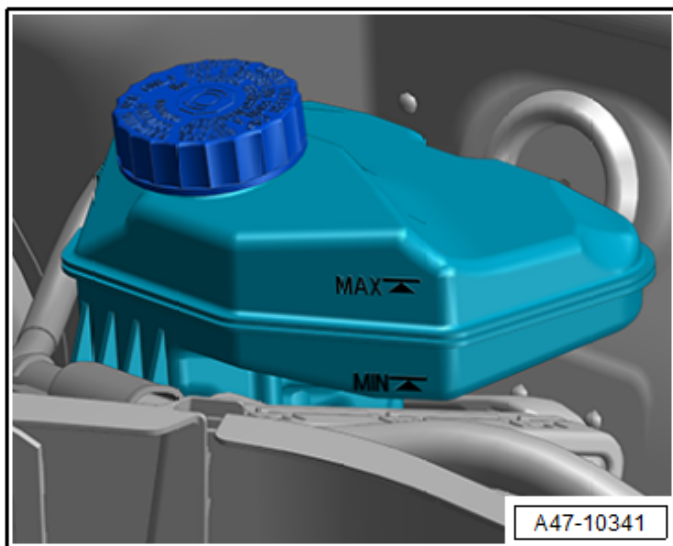

**Fill the brake fluid:**

- Fill the brake fluid reservoir up to the “MIN” mark.

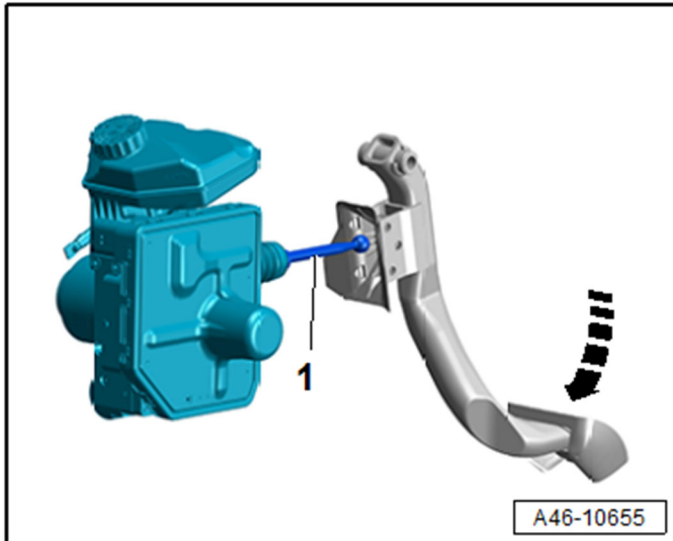

### Reconnect brake pedal:

- Hold the pushrod ball head <1> in front of the mount and push the brake pedal toward the brake pressure unit <arrow> until the ball head engages audibly.

### **⚠ WARNING**

**Faulty brakes increase the risk of an accident.**

Make sure the brakes are working correctly before driving the vehicle for the first time.

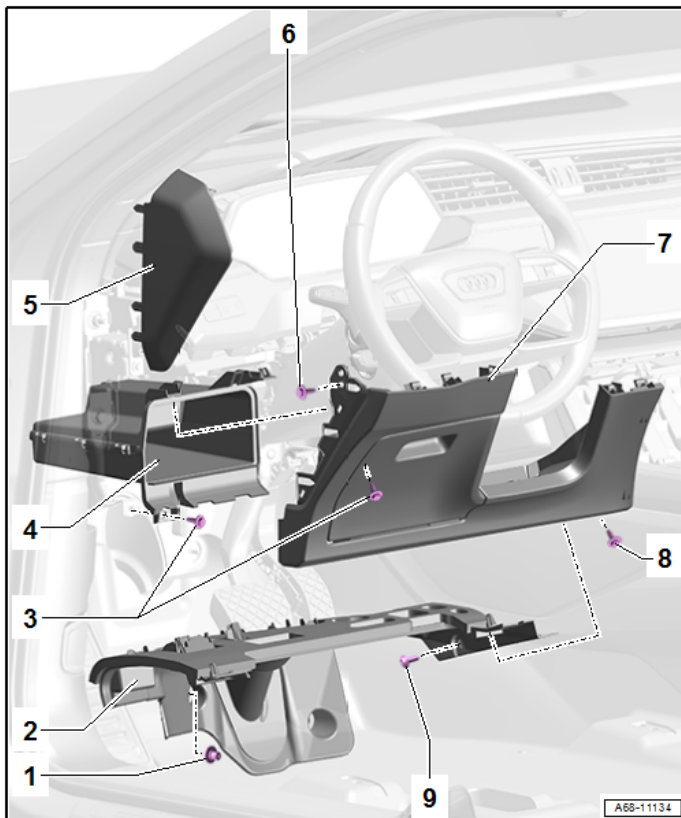

### Reassemble footwell vent, instrument panel trim and knee airbag:

- Reassembly is the reverse order of removal.
- Torque the knee airbag bracket bolts to 3 Nm.

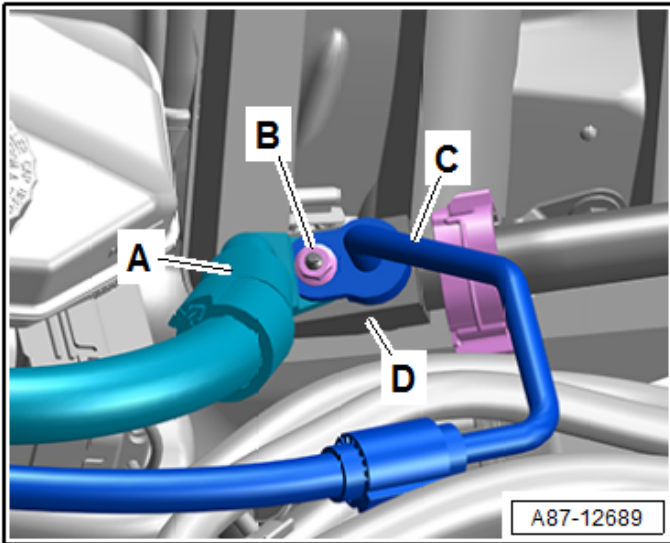

### Re-install refrigerant lines:

- Install new seal on lines <A> and <C>.

Line	Part Number	Part Description
A	4E0-260-749-C	O-ring
C	3D0-260-749-C	O-ring

- Coat new seals with refrigerant oil.
- Install lines and torque nut <B> to 8 Nm.



### Recharge A/C system:

- Perform the procedure as described in the A/C Service Station Owner's Manual.
- The quantity of refrigerant oil in the A/C Service Station is checked and if necessary corrected.
- The refrigerant quantity in the A/C Service Station is checked and if necessary corrected.
- For more information, refer to the Repair Manual:
  - ELSA Repair Manual: *Repair manual > Heating, Ventilation & Air Conditioning > Refrigerant R1234yf Servicing*

### Re-energize HV system:

- Follow the GFF test plan for restarting/recommissioning the high voltage system.
- Pay close attention to the test plan instructions when re-energizing the high-voltage system.
- The test plan will guide you through all of the re-energization steps. **READ EACH SCREEN CAREFULLY!!**
- **Refer to the Function Description tabs if necessary.**

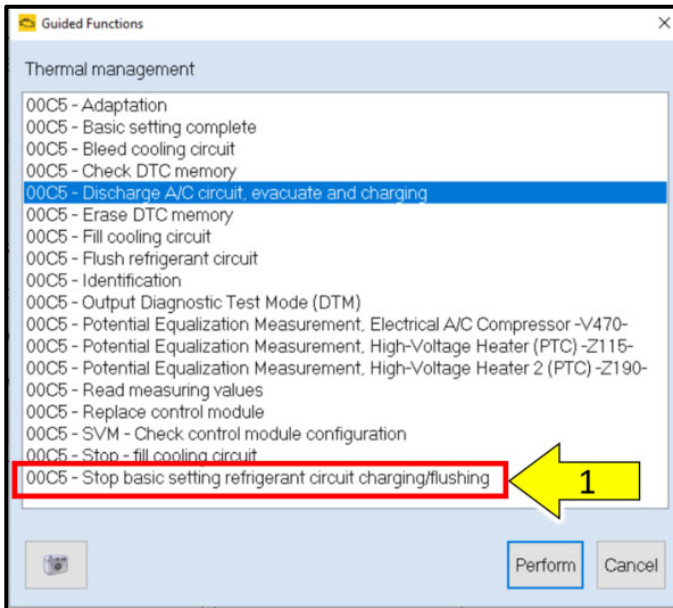

### Close refrigerant system valves:

- Follow the test plan for closing the refrigerant system valves:
  - Open the Guided Functions menu for Thermal Management by right clicking on Address 00C5.
  - Perform the test “00C5 – Stop basic setting refrigerant circuit charging/flushing” <1>.

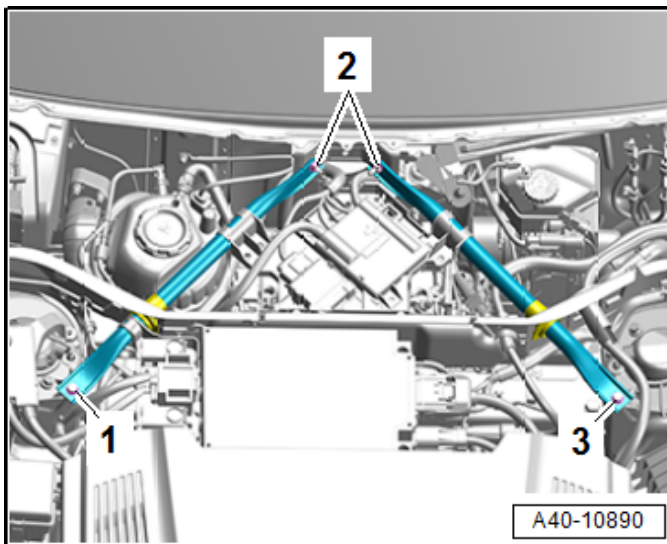

### Reinstall tower brace and windshield washer pump control module:

- Installation is the reverse order of removal.
- Torque bolts <3> and nuts <2> to 24 Nm.



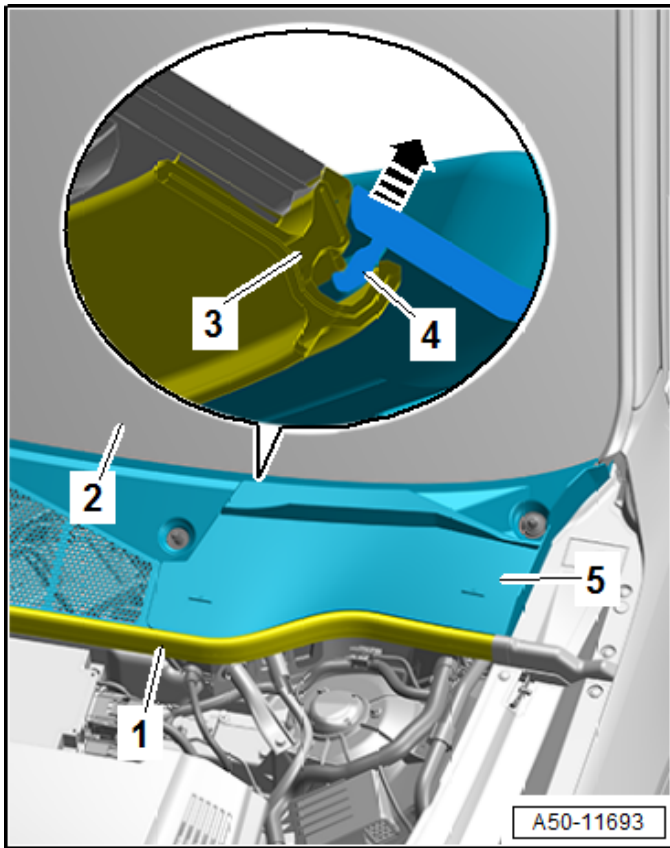

#### Reinstall plenum chamber cover:

- Installation is the reverse order of removal.
- The plenum chamber cover tab must be completely engaged in the windshield frame.

#### NOTE

If the plenum chamber cover is damaged or mounted incorrectly, water can flow into the fresh air intake duct. This can lead to complaints regarding odor coming from the heater/A/C system and/or moisture in the vehicle interior.

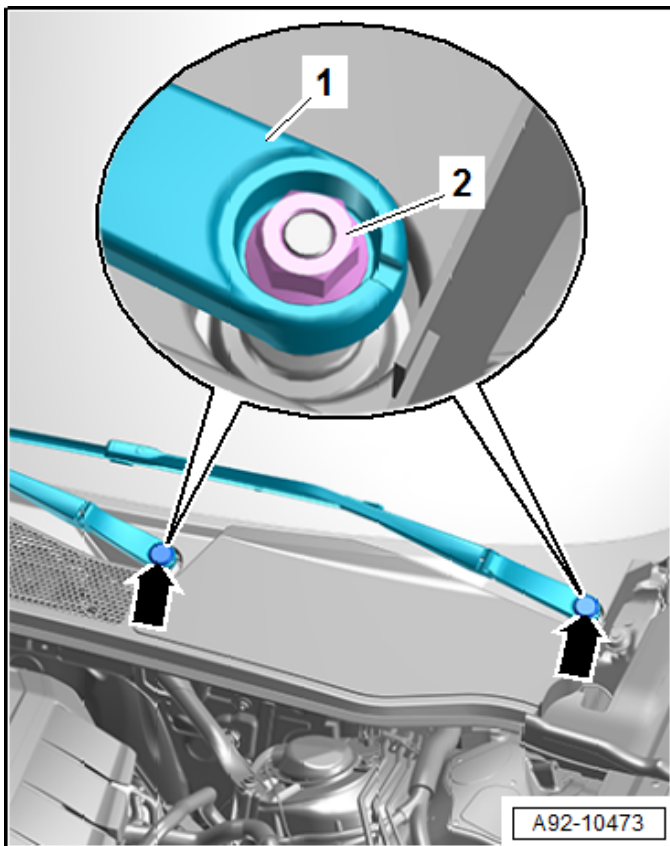

#### Reinstall wiper arms:

- Installation is the reverse order of removal.
- Reference previously made marks when installing wiper arms.
- Torque nuts <2> to 32 Nm.
- Install caps <arrows>.

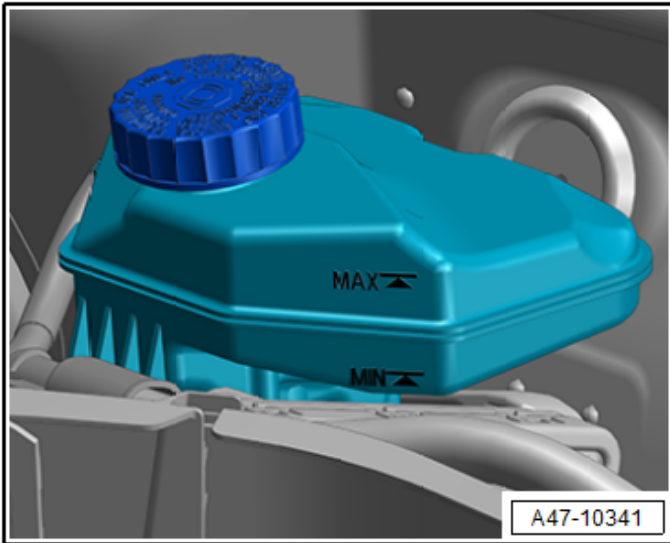

**Fill the brake fluid:**

- Fill the brake fluid reservoir up to the “MAX” mark.

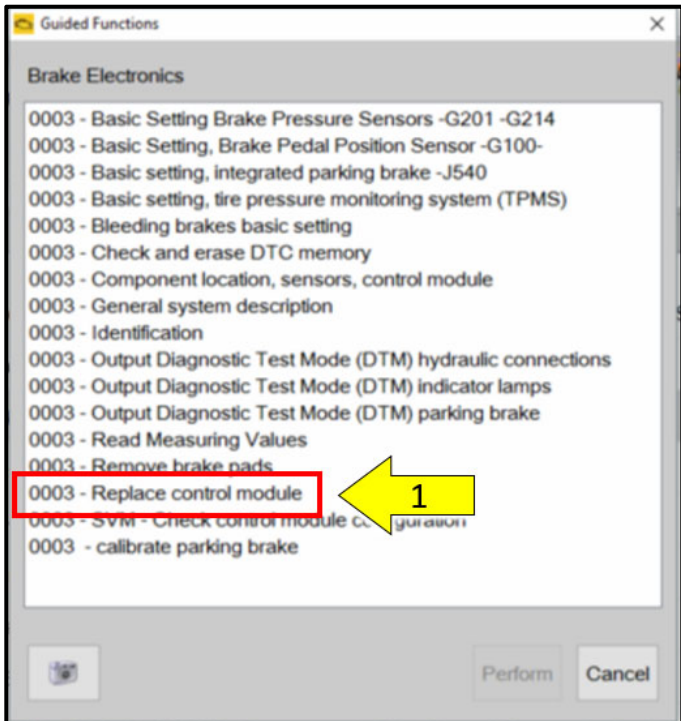

**Perform “Replace control module” test plan:**

- Open the Guided Functions menu for Brake Electronics by right clicking on Address 0003.
- Perform the test “0003 – Replace control module” <1>.



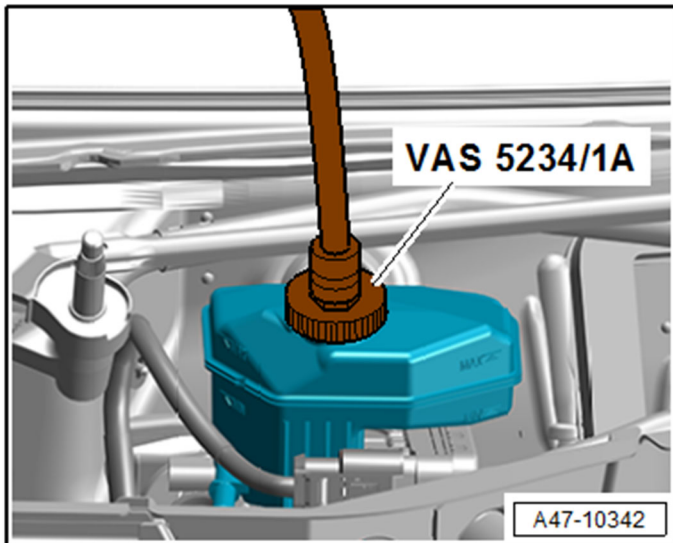

### Bleed brakes:

- Follow the test plan for bleeding the brakes in conjunction with the brake bleeding equipment:
  - Refer to ELSA Repair Manual: *Repair manual > Chassis > Brake System > 47 Hydraulic Components > Hydraulic System > Hydraulic System, Bleeding*
  - Open the Guided Functions menu for Brake Electronics by right clicking on Address 0003.
  - Perform the test “0003 – Bleeding brakes basic setting” <1>.
  - Perform any other test plans populated due to faults related with control module replacement.

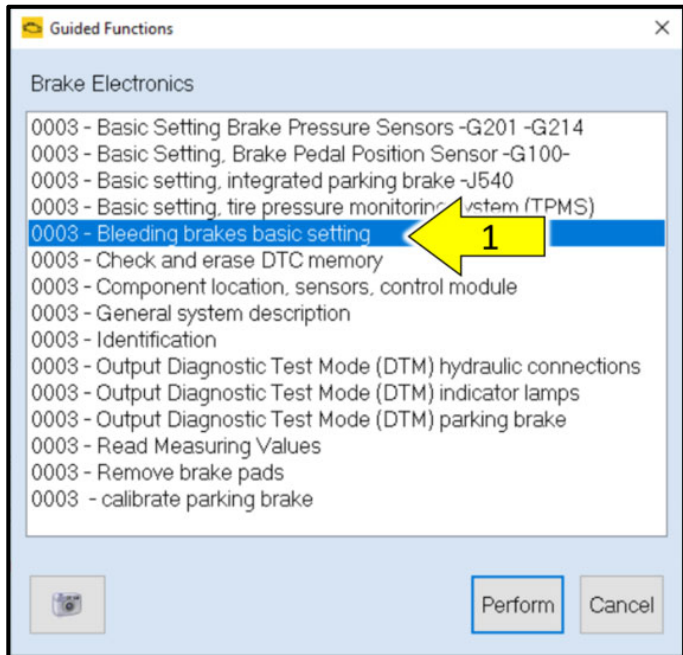

**WARNING**

**Faulty brakes increase the risk of an accident.**

Make sure the brakes are working correctly before driving the vehicle for the first time.

**WARNING**

**Risk of accident due to the brakes malfunctioning.**

Brake fluid must never come into contact with fluids containing mineral oils (oil, gasoline, cleaning solutions).

Wear safety gloves that are free of oil and grease.

**CAUTION**

**Risk of an accident due to the water content in the brake fluid being too high. Brake fluid is hygroscopic, meaning that it absorbs moisture from the surrounding air.**

**Brake failure due to the formation of steam bubbles.**

Store brake fluid in air-tight containers.

Immediately seal any open brake hoses and brake lines.

**CAUTION**

**There is a risk of contamination and paint damage from leaking brake fluid.**

Rinse off any leaking brake fluid immediately using plenty of water.

 **TIP**

Various event memory entries may be generated. Put the vehicle in a corresponding bus sleep mode after the repair in order to clear the faults.

To put the vehicle in bus sleep mode, disconnect the diagnostic tester, remove the key from the vehicle and lock the vehicle with the remote for 5 minutes.

**Road test:**

- Perform a short road test to verify brake functionality.

**Proceed to Section C**

## Section C – Campaign Completion Stamp

I certify that this campaign  
has been performed in strict  
accordance with the applicable  
Audi repair procedure.

SAGA Code: \_\_\_\_\_

Technician: \_\_\_\_\_

Date: \_\_\_\_\_

Item#: AUD4927ENG

- Once the campaign has been completed, the technician should stamp the repair order.
- Stamps are available for ordering through the Compliance Label Ordering Portal.
- **Proceed to Section D**

## Section D - Parts Return/Disposal

Properly store (retain), destroy or dispose of removed parts in accordance with all state/province and local requirements, unless otherwise indicated and/or requested through the Warranty Parts Portal (WPP) for U.S.