

Product Safety Recall

N212333380 Rear Seat Belt Retractor Bolt Not Installed



Release Date: September 2021

Revision: 01

Revision Description: This bulletin has been revised to include the customer letter. Please discard all previous copies of bulletin N212333380.

Attention: It is a violation of Federal law for a dealer to deliver a new motor vehicle or any new or used item of motor vehicle equipment (including a tire) covered by this notification under a sale or lease until the defect or noncompliance is remedied.

All involved vehicles that are in dealer inventory must be held and not delivered to customers, dealer traded, or used for demonstration purposes until the repair contained in this bulletin has been performed on the vehicle.

Make	Model	Model Year		RPO	Description
		From	To		
Cadillac	XT4	2019	2021		
Chevrolet	Malibu	2016	2021		

Involved vehicles are marked “open” on the Investigate Vehicle History screen in GM Global Warranty Management system. This site should always be checked to confirm vehicle involvement prior to beginning any required inspections and/or repairs.

Condition	General Motors has decided that a defect which relates to motor vehicle safety may exist in certain 2016 – 2021 Chevrolet Malibu and 2019 – 2021 Cadillac XT4 vehicles. In rare cases, plant technicians performing a repair during the assembly process may not have installed a fastener required to fully secure a rear seat belt retractor. This condition may exist on the right-hand side of affected Malibu vehicles or either side of affected XT4 vehicles. A seat belt retractor with a missing fastener may not properly restrain an occupant, increasing risk of occupant injury in a crash.
Correction	Dealers will check that the rear seat belt retractor fastener is present and properly torqued on the right-side of affected Chevrolet Malibu vehicles and both sides of affected Cadillac XT4 vehicles. Missing or improperly installed fasteners will be replaced and torqued to specification.

Parts

Quantity	Part Name	Part No.
1 (Malibu) 2 (XT4)	Seat Belt Retractor Bolt	11611776

It is estimated that there are only 438 involved vehicles that will require parts being replaced. **Due to the small number of vehicles anticipated that will need this repair and the limited initial parts availability, dealers are encouraged not to order these parts for use as shelf stock.**

Reminder: Parts may be removed from Retail Inventory Management (RIM). Dealers should review the affected parts to confirm RIM managed status. Parts may have quantity limiters in effect.

Warranty Information

Labor Operation	Description	Labor Time	Trans. Type	Net Item
9105916	Check Seat Belt Retractor Bolt and Torque to Spec XT4 (Driver and Passenger side, includes fastener replacement if necessary) Malibu (Passenger side) Add: Replace Fastener (Malibu only)	1.5 0.5 0.1	ZFAT	N/A
9105917	Customer Reimbursement Approved - For USA and Canada dealers only - For Export dealers only	N/A 0.2		*
9105918	Customer Reimbursement Denied – For USA dealers only	N/A		**

Note: To avoid having to “H” route the customer reimbursement transaction for approval, it must be submitted prior to the repair transaction.

* For USA and Canada: Submit the dollar amount reimbursed to the customer in Net/Reimbursement. Submit \$20.00 administrative allowance in Net/Admin Allowance.

For Export: Submit the dollar amount reimbursed to the customer in Net/Reimbursement.

Product Safety Recall

N212333380 Rear Seat Belt Retractor Bolt Not Installed



** Submit \$10.00 administrative allowance in Net/Admin Allowance.

Service Procedure

Malibu

1. Remove the Quarter Window Lower Trim Finish Panel on the passenger's side of the vehicle. Refer to *Quarter Window Lower Trim Finish Panel Replacement* in SI.

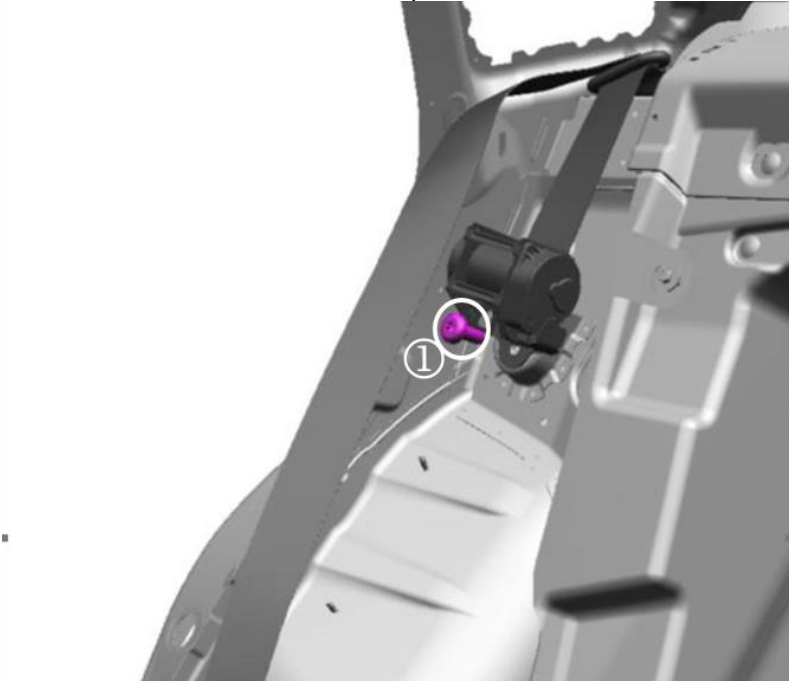

5893822

2. Check for the presence of a bolt at location (1), the seat belt retractor anchor.
 - If a bolt is present, using a torque wrench, ensure the bolt is torqued to 33 lb-ft (45 N-m).
 - If a bolt is **NOT** present, **OR** a bolt is present but not fully seated install a new bolt and run down the bolt until it is fully seated. These are self-tapping bolts, so it is normal for no threads to be present if the bolt is not installed.
 - Install the bolt, and then torque the bolt to 33 lb-ft (45 N-m).
3. Reinstall the Quarter Window Lower Trim Finish Panel. Refer to *Quarter Window Lower Trim Finish Panel Replacement* in SI.

XT4

1. Remove the Quarter Lower Rear Trim Panel on **both** sides of the vehicle. Refer to *Quarter Lower Rear Trim Panel Replacement* in SI.

Product Safety Recall

N212333380 Rear Seat Belt Retractor Bolt Not Installed

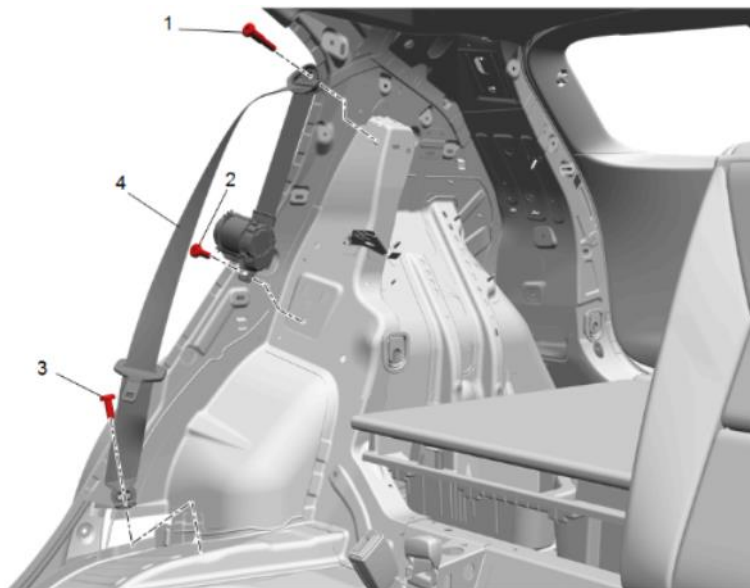

5081235

2. Check for the presence of a bolt at location (2), the seat belt retractor anchor, on **both** sides of the vehicle.
 - If a bolt is present, using a torque wrench, ensure the bolt is torqued to 33 lb-ft (45 N-m).
 - If a bolt is **NOT** present, **OR** a bolt is present but not fully seated, install a new bolt and run down the bolt until it is fully seated. These are self-tapping bolts, so it is normal for no threads to be present if the bolt is not installed.
 - Install the bolt, and then torque the bolt to 33 lb-ft (45 N-m).
3. Reinstall the Quarter Lower Rear Trim Panels. Refer to *Quarter Lower Rear Trim Panel Replacement* in SI.

Dealer Responsibility – For USA & Export (USA States, Territories, and Possessions)

It is a violation of Federal law for a dealer to deliver a new motor vehicle or any new or used item of motor vehicle equipment (including a tire) covered by this notification under a sale or lease until the defect or noncompliance is remedied.

The US National Traffic and Motor Vehicle Safety Act provides that each vehicle that is subject to a recall of this type must be adequately repaired within a reasonable time after the customer has tendered it for repair. A failure to repair within sixty days after tender of a vehicle is prima facie evidence of failure to repair within a reasonable time. If the condition is not adequately repaired within a reasonable time, the customer may be entitled to an identical or reasonably equivalent vehicle at no charge or to a refund of the purchase price less a reasonable allowance for depreciation. To avoid having to provide these burdensome remedies, every effort must be made to promptly schedule an appointment with each customer and to repair their vehicle as soon as possible. In the recall notification letters, customers are told how to contact the US National Highway Traffic Safety Administration if the recall is not completed within a reasonable time.

Dealer Responsibility – All

All new, used, GM Certified Used, courtesy transportation vehicles, dealer shuttle vehicles, etc. in dealers' possession and subject to this recall must be held and inspected/repared per the service procedure of this bulletin before customers take possession of these vehicles. Involved vehicles must be held and not delivered to customers, dealer-traded, released to auction, used for demonstration, or any other purpose.

All GM Certified Used vehicles currently in the dealers' inventory within the Certified Pre-Owned Inventory System (CPOIS) will be de-certified and must be held and remedied per the service procedure in this bulletin. Upon submitting an accepted/paid warranty transaction in the Global Warranty Management (GWM) system, the vehicle can be re-certified for sale within the CPOIS system, or once again be used in the CTP program.

Dealers are to service all vehicles subject to this recall at no charge to customers, regardless of mileage, age of vehicle, or ownership, from this time forward.

Customers who have recently purchased vehicles sold from your vehicle inventory, and for which there is no customer information indicated on the dealer listing, are to be contacted by the dealer. Arrangements are to be made to make the required correction according to the instructions contained in this bulletin. Recall follow-up cards should not be used for this purpose, since the customer may not as yet have received the notification letter.

Product Safety Recall

N212333380 Rear Seat Belt Retractor Bolt Not Installed



In summary, whenever a vehicle subject to this field action enters your vehicle inventory you must take the steps necessary to ensure the program correction has been made before selling the vehicle. In addition, for vehicles entering your facility for service, you are required to ensure the customer is aware of the open field action and make every reasonable effort to implement the program correction as set forth in this bulletin prior to releasing the vehicle.

Dealer Reports

For dealers with involved vehicles, a listing has been prepared and will be available through GM GlobalConnect Maxis Field Action Reports or sent directly to export dealers. The Inventory tab of the dealer reports will contain VINs that apply to this recall. This information is intended to assist dealers with the **PROMPT COMPLETION** of these vehicles. The Customer In-Service tab will contain customer names and addresses from Motor Vehicle Registration Records. The use of such motor vehicle registration data for any purpose other than follow-up necessary to complete this recall may be a violation of law in several states.

Courtesy Transportation – For USA & Canada

Courtesy transportation is available for customers whose vehicles are involved in a product program and still within the warranty coverage period. See General Motors Service Policies and Procedures Manual for courtesy transportation program details.

Customer Notification

USA & Canada - General Motors will notify customers of this recall on their vehicle.

Export - Letters will be sent to known owners of record located within areas covered by the US National Traffic and Motor Vehicle Safety Act.

Customer Reimbursement

Customer requests for reimbursement of previously paid repairs to correct the condition described in the bulletin can be submitted at anytime to the dealer. See General Motors Service Policies and Procedures Manual, Product Field Action Customer Reimbursement Procedure (USA & Canada) or local Policies and Procedures, for details.

GM bulletins are intended for use by professional technicians, NOT a "do-it-yourselfer". They are written to inform these technicians of conditions that may occur on some vehicles, or to provide information that could assist in the proper service of a vehicle. Properly trained technicians have the tools, equipment, safety instructions, and know-how to do a job properly and safely. If a condition is described, DO NOT assume that the bulletin applies to your vehicle, or that your vehicle will have that condition. See your dealer for information on whether your vehicle may benefit from the information.



**We Support
Voluntary Technician
Certification**



IMPORTANT SAFETY RECALL

September 2021

This notice applies to your vehicle, **VIN:** _____

Dear General Motors Customer:

This notice is sent to you in accordance with the National Traffic and Motor Vehicle Safety Act.

General Motors has decided that a defect, which relates to motor vehicle safety, exists in all or certain 2019-2021 Cadillac XT4 and 2016-2021 Chevrolet Malibu vehicles. As a result, GM is conducting a safety recall. We apologize for this inconvenience. However, we are concerned about your safety and continued satisfaction with our products.

IMPORTANT

- Your vehicle is involved in GM safety recall N212333380.
- Schedule an appointment with your GM dealer.
- This service will be performed for you at **no charge**.

Why is your vehicle being recalled?

The rear seat belt retractors may be improperly secured with loose or missing fasteners. This condition may exist on the right-hand side of affected Malibu vehicles or either side of affected XT4 vehicles. An improperly secured seat belt retractor may not function properly in a crash, increasing the risk of injury.

What will we do?

Your GM dealer will inspect and tighten the rear seat belt retractors, as necessary, free of charge. Missing or improperly installed fasteners will be replaced. This service will be performed for you at **no charge**. Because of service scheduling requirements, it is likely that your dealer will need your vehicle longer than the actual inspection and service correction time of approximately 1 hour and 40 minutes.

What should you do?

You should contact your GM dealer to arrange a service appointment as soon as possible.

Did you already pay for this repair?

Even though you may have previously had repairs for this condition, you will still need to take your vehicle to your dealer for additional repairs. If you have already paid for repairs for the recall condition, please complete the enclosed reimbursement form and present it to your dealer with all required documents. Working with your dealer will expedite your request, however, if this is not convenient, you may mail the completed reimbursement form and all required documents to Reimbursement Department, PO Box 33170, Detroit, MI 48232-5170.

Do you have questions?

If you have questions or concerns that your dealer is unable to resolve, please contact the appropriate Customer Assistance Center at the number listed below.

Division	Number	Text Telephones (TTY)
Cadillac	1-800-333-4223	1-800-833-2622
Chevrolet	1-800-630-2438	1-800-833-2438
Puerto Rico – English	1-800-496-9992	
Puerto Rico – Español	1-800-496-9993	
Virgin Islands	1-800-496-9994	

If after contacting your dealer and the Customer Assistance Center, you are still not satisfied we have done our best to remedy this condition without charge and within a reasonable time, you may wish to write the Administrator, National Highway Traffic Safety Administration, 1200 New Jersey Avenue, SE, Washington, DC 20590, or call the toll-free Vehicle Safety Hotline at 1.888.327.4236 (TTY 1.800.424.9153), or go to <http://www.safercar.gov>. The National Highway Traffic Safety Administration Campaign ID Number for this recall is 21V649.

Product Safety Recall

N212333380 Rear Seat Belt Retractor Bolt Not Installed



Federal regulation requires that any vehicle lessor receiving this recall notice must forward a copy of this notice to the lessee within ten days.

Regina A. Carto
Vice President
Global Product Safety and Systems

Enclosure
GM Recall: N212333380