



# RECALL CAMPAIGN BULLETIN

Classification: BT21-011A	Reference: NTB21-062A	Date: August 5, 2021
------------------------------	--------------------------	-------------------------

## VOLUNTARY SAFETY RECALL CAMPAIGN 2021 ROGUE SPORT; BACK DOOR HINGE REPLACEMENT

This bulletin has been amended. See **AMENDMENT HISTORY** on the last page.  
Discard all previous versions of this bulletin.

**CAMPAIGN ID #:** R21A7  
**APPLIED VEHICLES:** 2021 Rogue Sport (J11)

**Check Service COMM or Dealer Business Systems (DBS)  
National Service History to confirm campaign eligibility.**

### INTRODUCTION

Nissan is conducting this voluntary safety recall campaign, on certain specific model year 2021 Rogue Sport vehicles, to replace both back door hinges. This service will be performed at no charge to the customer for parts or labor.

### IDENTIFICATION NUMBER

Nissan has assigned identification number R21A7 to this campaign. This number must appear on all communication and documentation of any nature dealing with this campaign.

### DEALER RESPONSIBILITY

It is the dealer's responsibility to check Service COMM or Dealer Business Systems (DBS) National Service History for the campaign status on each vehicle falling within the range of this voluntary safety recall which for any reason enters the service department. This includes vehicles purchased from private parties or presented by transient (tourist) owners and vehicles in a dealer's inventory. **Federal law requires that new vehicles in dealer inventory which are the subject of a safety recall must be corrected prior to sale. Failure to do so can result in civil penalties by the National Highway Traffic Safety Administration.** While federal law applies only to new vehicles, Nissan strongly encourages dealers to correct any used vehicles in their inventory before they are retailed.

Nissan Bulletins are intended for use by qualified technicians, not 'do-it-yourselfers'. Qualified technicians are properly trained individuals who have the equipment, tools, safety instruction, and know-how to do a job properly and safely. **NOTE:** If you believe that a described condition may apply to a particular vehicle, DO NOT assume that it does. See your Nissan dealer to determine if this applies to your vehicle.

## SERVICE PROCEDURE

**IMPORTANT:** Prior to starting the back door hinge replacement procedure, sublet the back door hinges to a body shop to be painted to match the vehicle's paint color code.

### **NOTICE**

To prevent damage to the back door hinges, be sure the studs on the body side of the back door hinges are not painted. Paint on the studs will damage the preinstalled stud gaskets and could make reinstallation difficult.

1. Open the back door and both rear passenger doors.
  - Remove the tonneau cover assembly from the rear cargo area, if equipped.



Figure 1

2. Fold both the rear seat backs into the flat position.



Figure 2

3. Remove the body side welt (weather strip) from the body side of both rear passenger doors that covers the luggage upper finisher (upper C pillar trim), as shown in Figure 3.



Figure 3

4. Remove the upper portion of the weather strip from the body side of the back door opening, as shown in Figure 4.



Figure 4

5. On the right hand side of the vehicle, remove the trim cover shown in Figure 5, using a finesse stick.

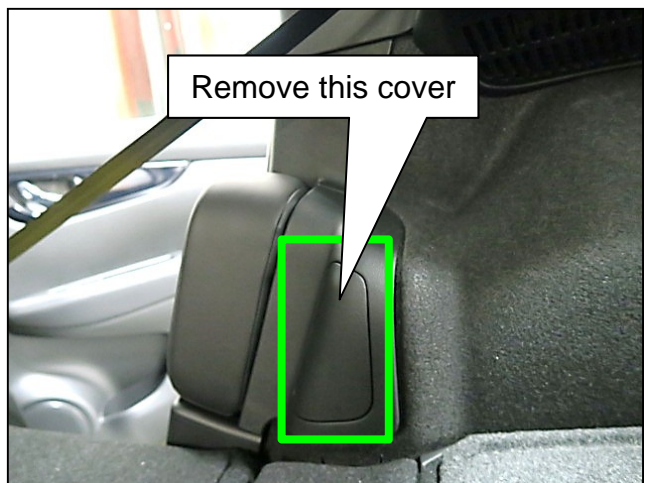

Figure 5

6. Remove the rear back-side base bracket bolt.

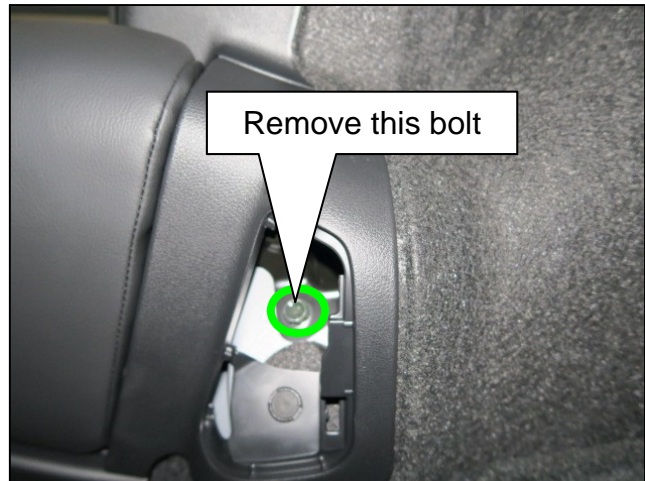

Figure 6

7. To protect the rear C pillar trim panels, apply masking tape to the upper and lower trim panels, as shown in Figure 7.

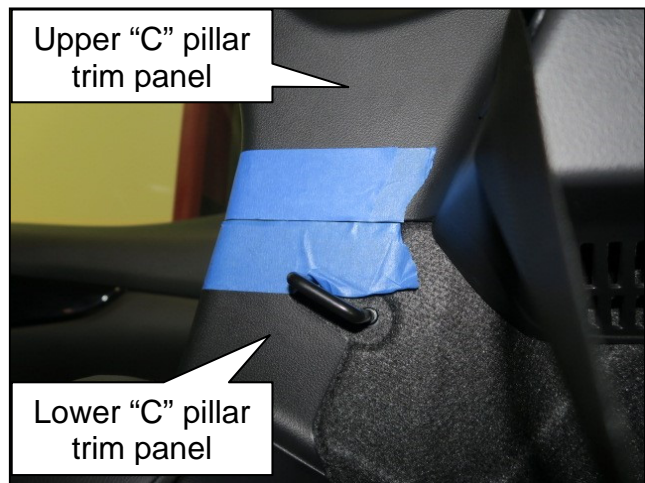

Figure 7

8. Disengage the upper clip of the lower C pillar trim panel and pull away from the upper C pillar trim panel.

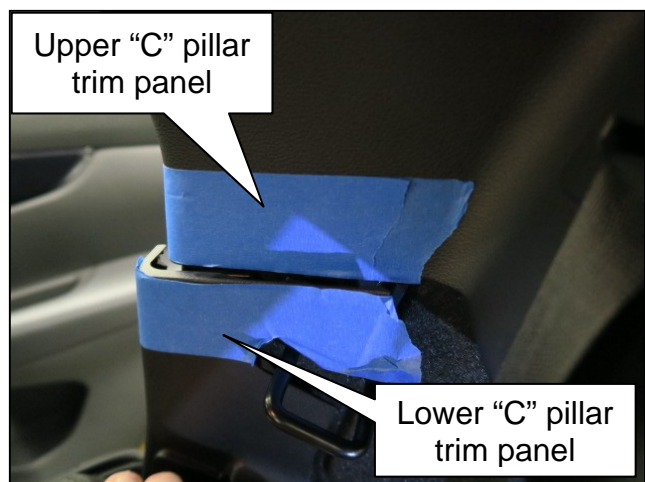

Figure 8

9. Disengage the 2 plastic clips and the 1 metal clip from the front edge of the upper C pillar trim panel.

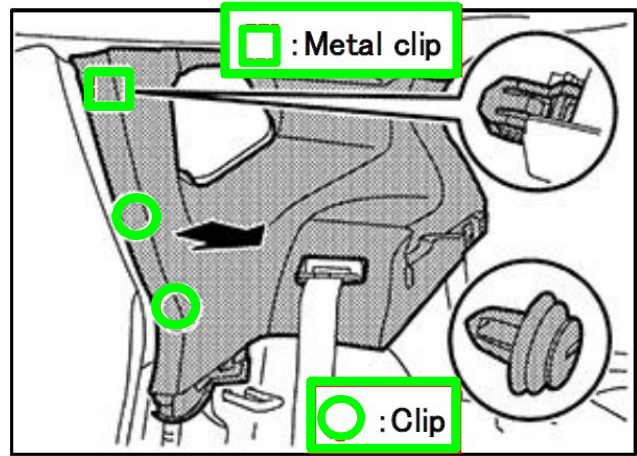

Figure 9

10. Disengage the 2 plastic clips and the 1 metal clip from the rear edge of the upper C pillar trim panel.

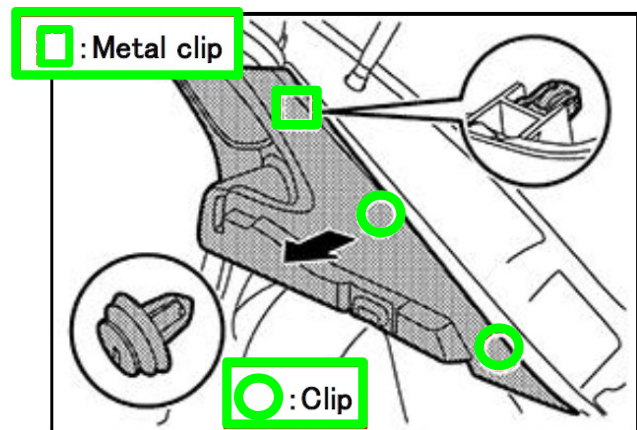

Figure 10

11. Disengage the upper metal clip of the upper C pillar trim panel by pulling downward.

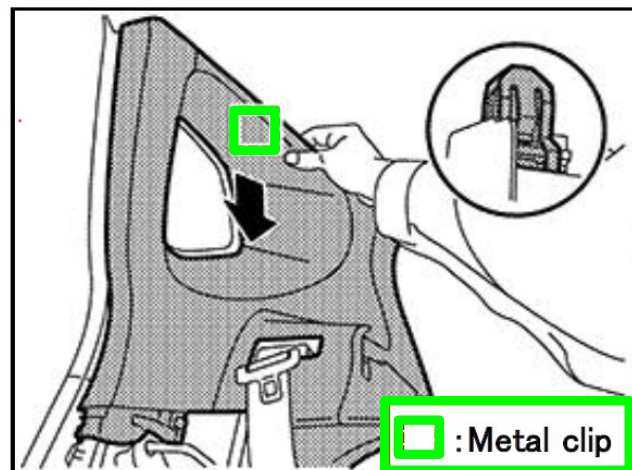

Figure 11

12. Lower the upper C pillar trim panel and lay it in the cargo area.

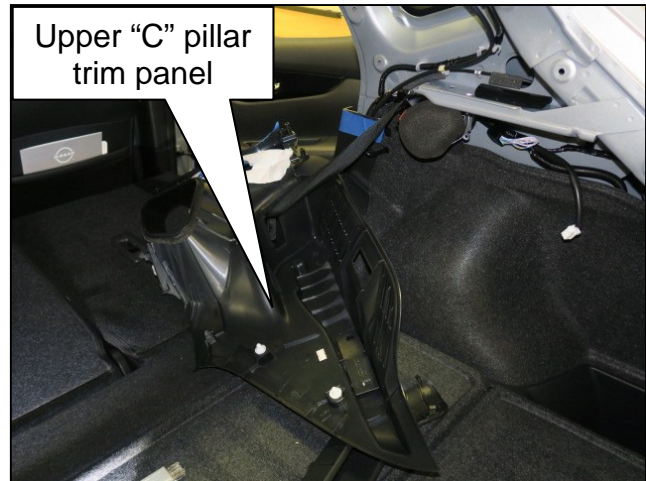

Figure 12

13. Perform steps 5 - 12 for the left hand side, and then proceed to step 14.

14. Using a forked finesse stick, remove the 3 rear headliner retaining clips.

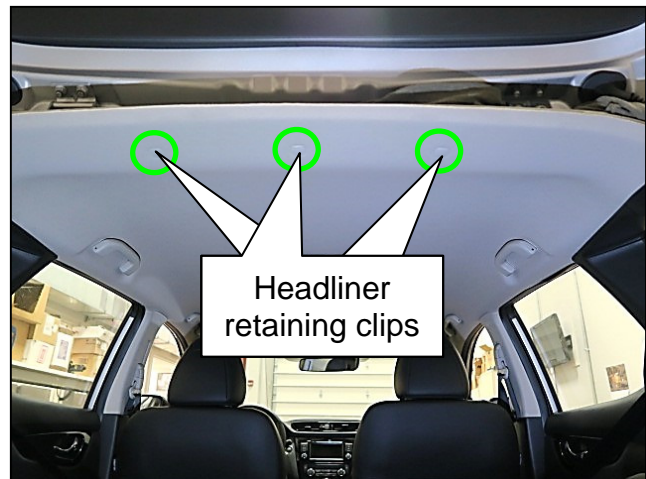

Figure 13

15. Starting on the right hand side, place folded shop rags between the back door and the body, on both sides of the right side hinge.

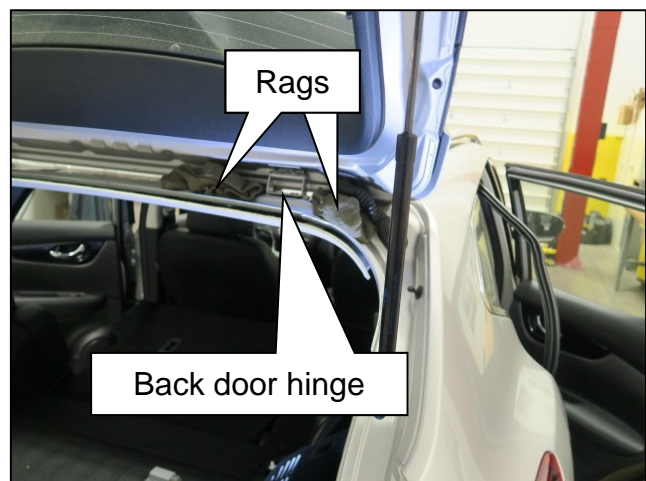

Figure 14

16. To stabilize the back door, place a suitable jack stand under the right hand corner of the back door.
- To prevent damage to the back door, use a shop rag or a suitable protective cloth on top of the jack stand.

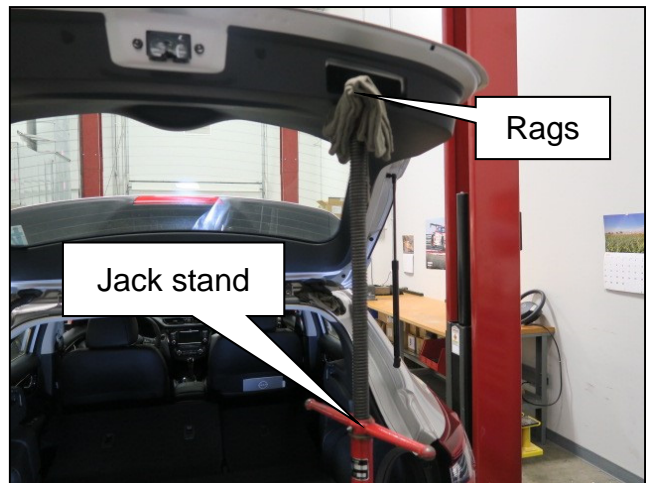

Figure 15

17. Remove the back door hinge mounting nuts.
- Slightly lower the rear of the headliner using a suitable tool, loosen and remove the 2 lower back door hinge mounting nuts.
- IMPORTANT:** Be careful not to crease or stain the headliner.
- Remove the 2 upper back door hinge mounting nuts.

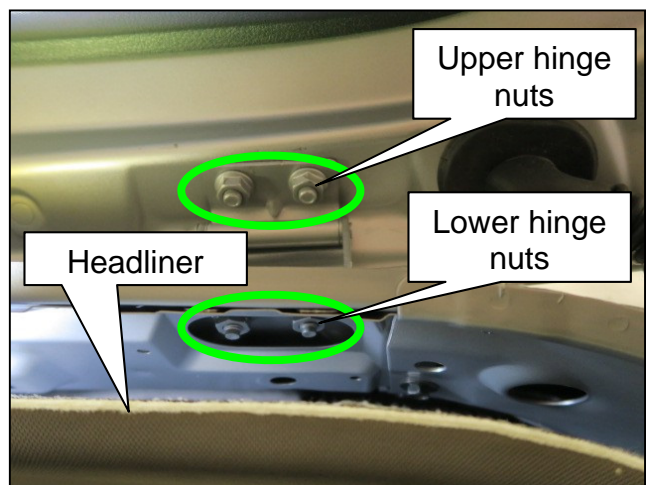

Figure 16

18. Using a small flat-blade screwdriver, carefully separate the sealer from both sides and the front of the back door hinge.

**IMPORTANT:** Be careful not to scratch the body finish.

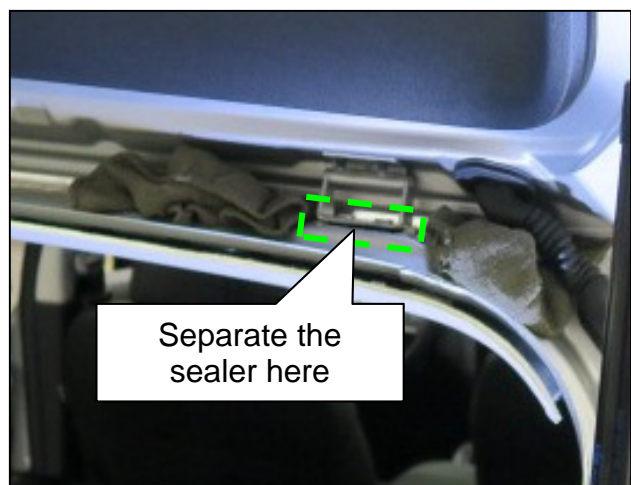

Figure 17

19. Carefully disengage the lower back door stay retaining clip and remove the lower back door stay from the ball stud mount.

- Allow the back door stay to hang freely, as shown in Figure 18.

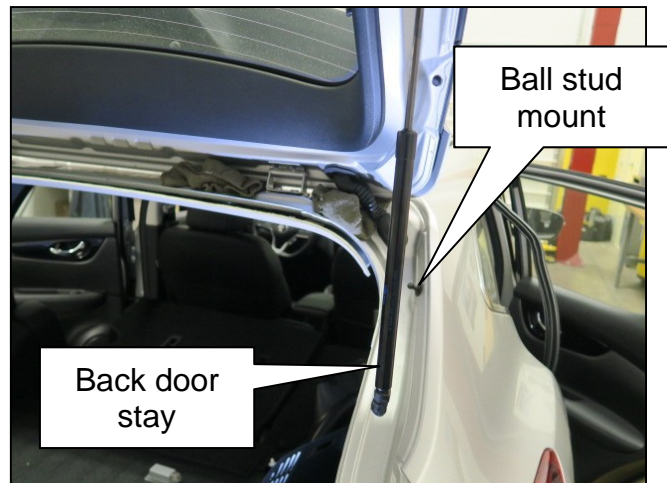

Figure 18

20. Lift the right hand side of the back door approximately 2 inches (51 mm) to allow clearance to remove the hinge (Figure 19).

- Remove the upper portion of the hinge from the stud on the rear back door (Figure 19).
- Remove the hinge from the vehicle (Figure 20).

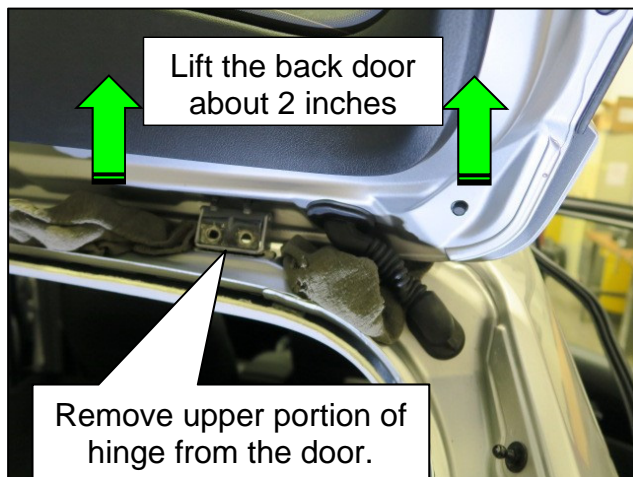

Figure 19



Figure 20

21. Carefully clean all of the old sealer and stud gasket material from the body.

**IMPORTANT:** Be careful not to scratch the body finish.

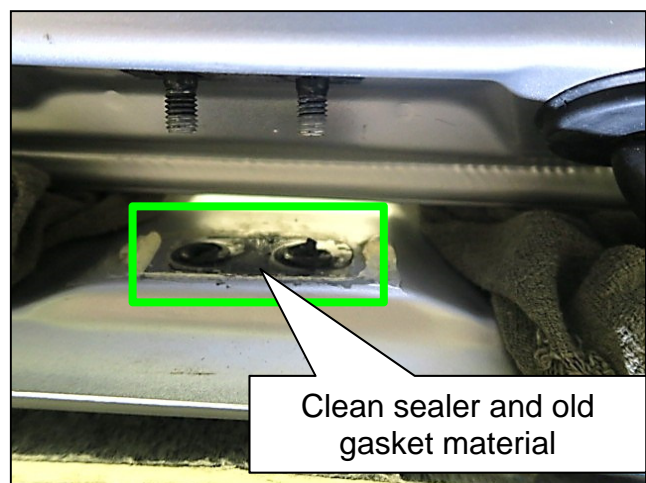

Figure 21



22. Install a new back door hinge into place.

**IMPORTANT:** Be sure the new hinge has been painted to match the vehicle's exterior color before installing.



Figure 22

23. Install and tighten all 4 hinge mounting nuts to the specified torque.

- Back door hinge nut torque:  
26.0 N•m (2.7 kg-m, **228 in-lb**)

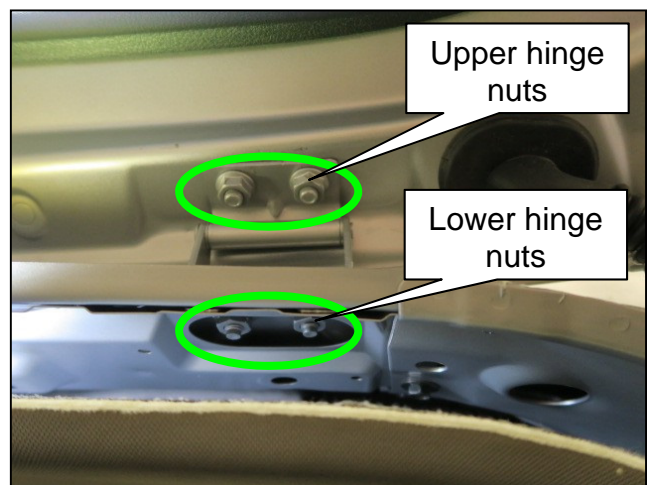

Figure 23

24. Apply a small bead of Fusor 800DTM sealant along the seam of the rear and both sides of the body side portion of the hinge, as shown in Figure 24.

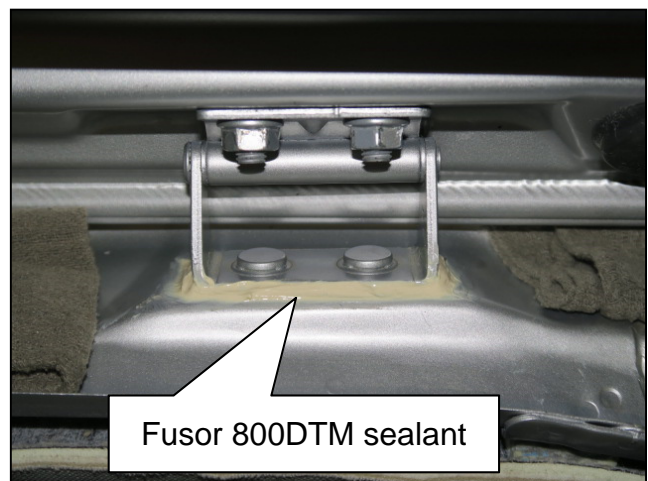

Figure 24

25. Reinstall the back door stay to the ball stud mount.
- Verify that the back door stay retaining clip is fully engaged.

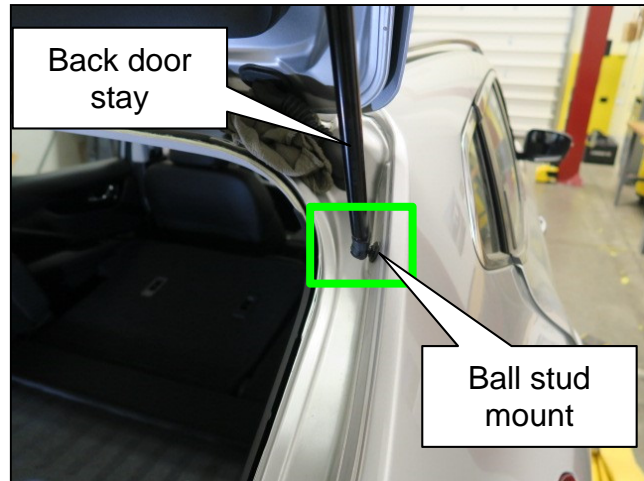

Figure 25

26. Perform steps 15 - 25 for the left hand side hinge, and then proceed to step 27.
27. Once the body sealer is dry, apply touch-up paint to the body sealer of both hinges.
28. Reassemble the vehicle in the reverse order of removal.
- Tighten the rear back-side base bracket bolts to 25.0 N•m (2.6 kg-m, **216 in-lb**).
29. Close the back door and inspect the body and door fitment. Adjust the body fitment as needed using the ESM section below.
- **REPAIR > BODY EXTERIOR, DOORS, ROOF & VEHICLE SECURITY > DOOR & LOCK > REMOVAL AND INSTALLATION > BACK DOOR ASSEMBLY > BACK DOOR ASSEMBLY: Adjustment**

## PARTS INFORMATION

DESCRIPTION	PART NUMBER	QUANTITY
HINGE ASSY – BACK DOOR	90400-6MA0A	2
SEAM SEALER (Fusor 800DTM)	999MP-9G000P (1)	(2) As Needed

- (1) Order this item through the Nissan Maintenance Advantage program: Phone 877-NIS-NMA1 (877-647-6621). Website order via link on the dealer portal; [www.NNAnet.com](http://www.NNAnet.com) and click on the “Maintenance Advantage” link.
- (2) One part contains enough sealer for multiple repairs. DO NOT use the part number on the claim.

## EXPENSE CODE

EXPENSE CODE	DESCRIPTION	MAX AMOUNT
009	Seam Sealer (Fusor 800DTM)	\$1.00
512	Body Shop Work	\$255.00

## CLAIMS INFORMATION

Submit a “CM” line claim using the following claims coding:

CAMPAIGN (“CM”) ID	DESCRIPTION	OP CODE	FRT
R21A7	Replace Both Rear Back Door Hinges <u>with</u> AVM	R21A70	1.5
	Replace Both Rear Back Door Hinges <u>without</u> AVM	R21A71	1.1

## AMENDMENT HISTORY

PUBLISHED DATE	REFERENCE	DESCRIPTION
July 12, 2021	NTB21-062	Original bulletin published
August 5, 2021	NTB21-062A	Updated torque specifications in step 23 and step 28, Updated <b>PARTS INFORMATION</b>