



Revision (1) August 2021

Dealer Service Instructions for:

Safety Recall Y24 / NHTSA 21V-309

ABS Hydraulic Control Unit

NOTE: all VINs in this recall now have parts available.

Remedy Available

2020 - 2021 (GA) Alfa Romeo Giulia

2019 - 2021 (GU) Alfa Romeo Stelvio

NOTE: Some vehicles above may have been identified as not involved in this recall and therefore have been excluded from this recall.

IMPORTANT: Some of the involved vehicles may be in dealer new vehicle inventory. Federal law requires you to complete this recall service on these vehicles before retail delivery. Dealers should also consider this requirement to apply to used vehicle inventory and should perform this recall on vehicles in for service. Involved vehicles can be determined by using the VIP inquiry process.

Subject

The Anti-Lock Brake System (ABS) Hydraulic Control Unit (HCU) on about 9 of the above vehicles may have a missing or partially missing weld of the rotor to the shaft of the brushless motor. During a hard braking maneuver, the ABS HCU rotor and shaft may separate, which could lead to a reduction in braking assistance and loss of ABS functionality. Full mechanical braking is still available. The loss of braking assistance and ABS functionality may reduce the overall braking performance which can cause a vehicle crash without prior warning.

Repair

Replace the Anti-Lock Brake System (ABS) Hydraulic Control Unit (HCU).

Alternate Transportation

Dealers should attempt to minimize customer inconvenience by placing the owner in a loaner vehicle if the vehicle must be held overnight.

Parts Information

Since there is a unique part to VIN relationship and very low volume for this campaign, part orders will be processed on the dealer's behalf. Upon identification of a VIN included in this recall, please send an email to **campaignteam@fcagroup.com** with the following details. An order will be placed and expedited upon approval.

Please include the following:

- 1) Dealer code
- 2) VIN(s)

Parts Return

No parts return required for this campaign.

Special Tools

The following special tools are required to perform this repair:

- NPN wiTECH MicroPod II
- NPN Laptop Computer
- NPN wiTECH Software
- C-4829A (1823015000) Trim Stick - removing lever
- 2000001400 Cap, Master Cylinder
- NPN Brake System Bleeding Equipment
- 2000010500 Brake Switch Pliers
- NPN R-1234yf refrigerant recovery recycling charging station that meets SAE standard J2843

Service Procedure

Refer to the appropriate repair procedure based on vehicle and engine combination.

- Section A. (GA) Alfa Romeo Giulia with EC2-2.0L engine. [Page 4](#)
- Section B. (GA) Alfa Romeo Giulia with EEC-2.9L engine. [Page 25](#)
- Section C. (GU) Alfa Romeo Stelvio with EC2-2.0L engine. [Page 57](#)

A. (GA) Alfa Romeo Giulia with EC2-2.0L engine.

1. Position the vehicle on a suitable hoist.
2. Perform the electric handbrake disengagement procedure. Connect the wiTECH diagnosis equipment to the vehicle data link connector of the vehicle, select Antilock Brake System (ABS) in the “**Miscellaneous Functions**” select “**Electric Park Brake (EPB)**”, then start the “**Maintenance Mode**”.

NOTE: After completing the ABS control module replacement, connect the wiTECH diagnosis equipment to the vehicle data link connector, go to "ABS control module" and start the "Control module replacement" procedure.

3. Raise the door windows to the upper end of travel position.

NOTE: Disconnecting the battery when the windows are in a position other than the upper end of travel will entail the need to run the window end of travel learning procedure.

4. Open the luggage compartment lid and support it so it will not close.

NOTE: If the luggage compartment lid closes while the battery is disconnected, it will not be possible to reopen it. The rear seat may need to be removed to gain access to the luggage compartment area.

Service Procedure [Continued]

5. To be able to reopen the luggage compartment lid, even if it accidentally closes with the battery disconnected, before disconnecting the battery, it is necessary to unscrew the cap (1b), release the pull cord hooked onto it and leave it hanging out of the luggage compartment. Then, by working on the pull cord, an emergency luggage compartment lid lock release can be obtained. The pull cord operates on the lever (1a) inside (Figure 1).

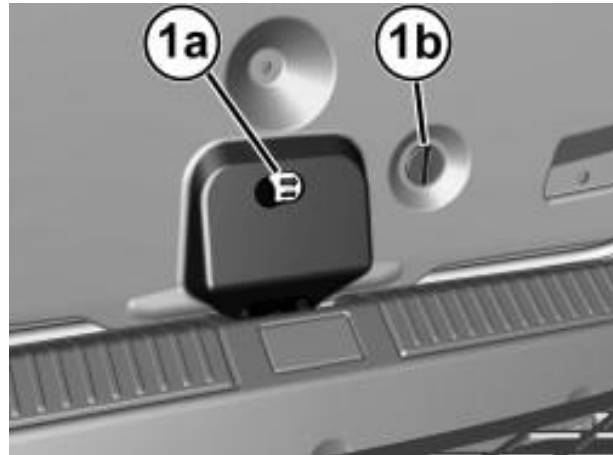
**Figure 1 – Lid Lock Release**

6. The ignition must be in the **OFF** position and the vehicle must remain powered down for at least 1 minute prior to proceeding.
7. Remove the battery cover (1b) by releasing retainers (1a) (Figure 2).

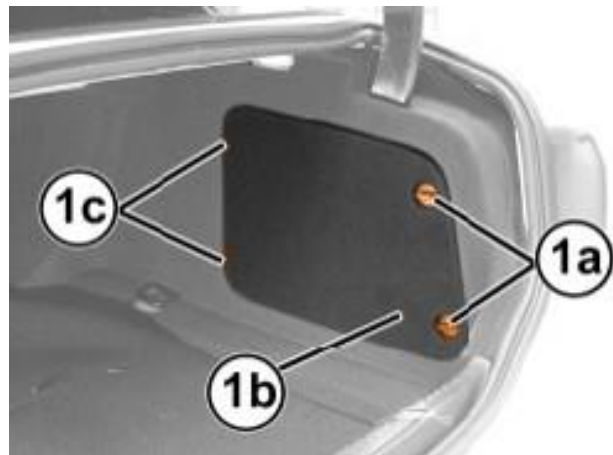
**Figure 2 – Battery Cover**

Service Procedure [Continued]

8. If equipped with an Intelligent Battery Sensor (IBS), disconnect the IBS connector.

9. Press the release button (1a) then disconnect and isolate the battery negative cable (1b) from the post (1c) (Figure 3).



Figure 3 – Battery Negative Cable

10. Remove the console side closure (1a) by disengaging its inner retainers (1b) with the Trim Stick C-4829A (1823015000) (Figure 4).

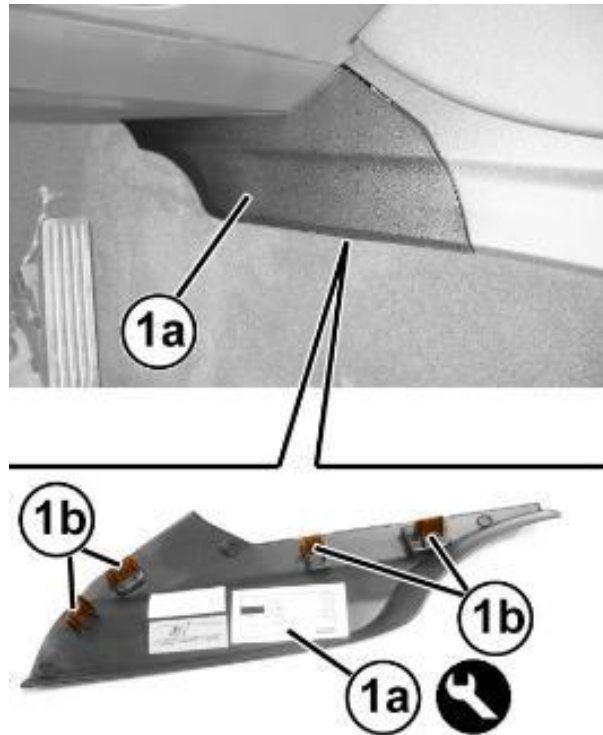

Figure 4 – Console Side Closure

Service Procedure [Continued]

11. Unscrew the screws from the holes (1a) of the bottom trim (1b) to be removed (Figure 5).

12. Move the bottom trim (1b) back and disengage the retainers (2a) (Figure 5).

13. Lower the bottom trim (1b) and disconnect the electrical connections from the courtesy lights (3a) and (3b) (Figure 5).

14. Remove the bottom trim (1b) (Figure 5).

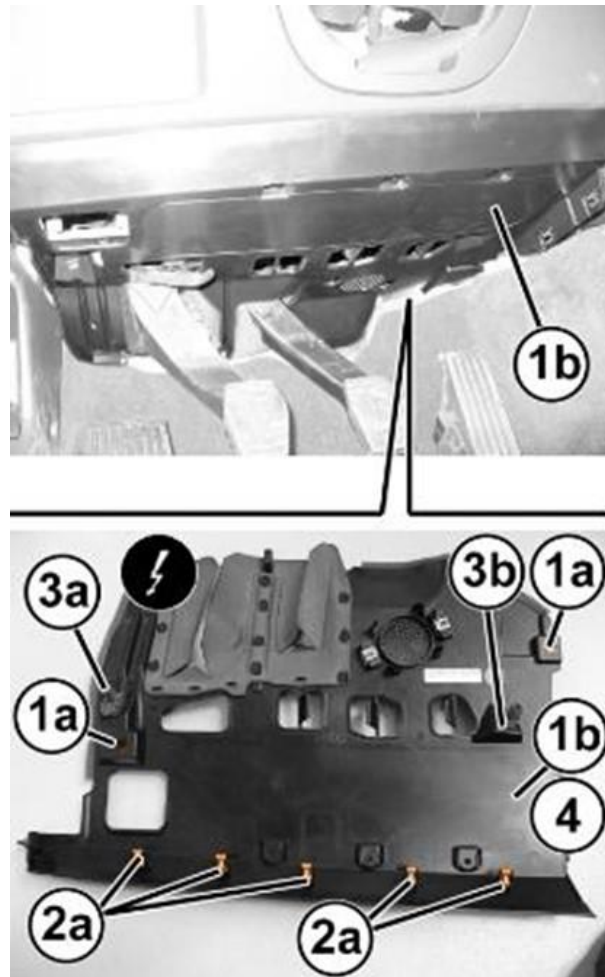

Figure 5 – Bottom Trim

15. Use tool Trim Stick C-4829A (1823015000) to disconnect the retaining pin with central pin (1a) and release the air vent (2a) (Figure 6).

CAUTION: Carefully move the air vent (2a) only when accessing the ABS module fasteners to avoid damaging it (Figure 6).

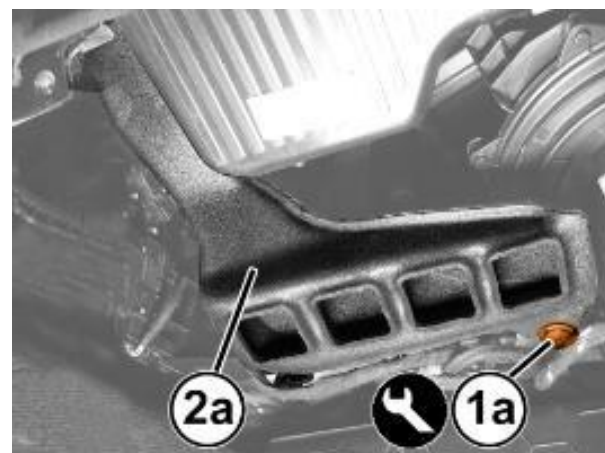

Figure 6 – Air Vent

Service Procedure [Continued]

16. Disengage from the retaining pins and remove the soundproofing cover (1a) complete with seal (1b) for the engine oil filler (Figure 7).

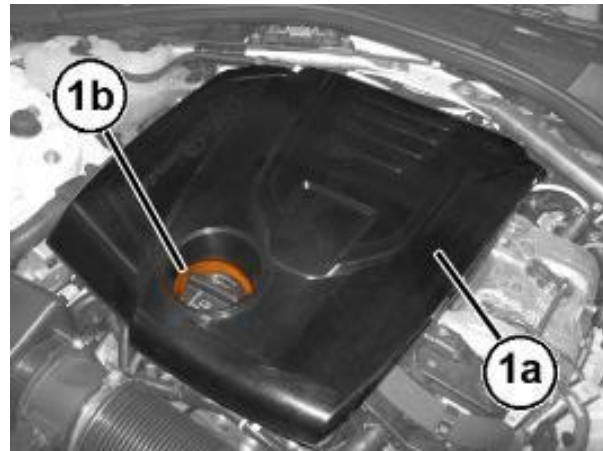

Figure 7 – Soundproofing Cover

17. Release the nut cover (1) at the base of the windshield wiper arm (Figure 8).

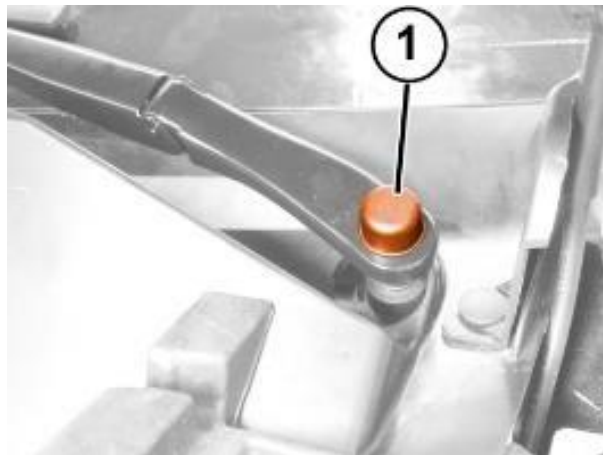

Figure 8 – Wiper Arm Nut Cover

Service Procedure [Continued]

18. Remove the nut (1a) and keep the washer (1b) (Figure 9).
19. Remove the wiper arm (2a) (Figure 9).

NOTE: If necessary, remove the wiper arm using a suitable extractor to release the ribbed truncated cone coupling (3a) (Figure 9).

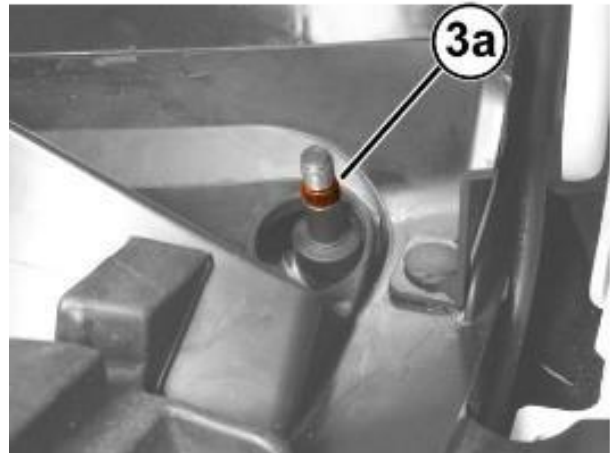
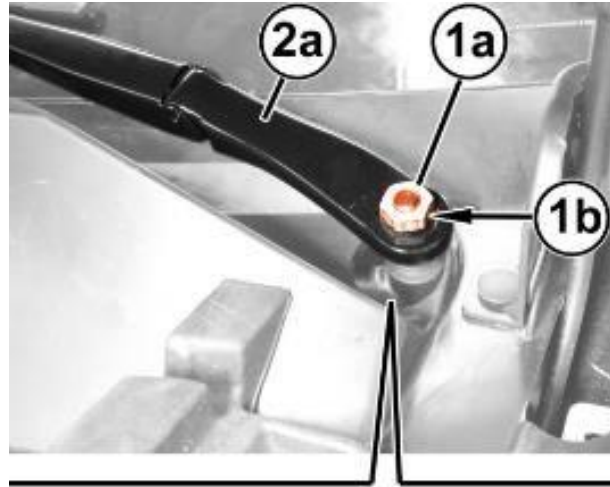

Figure 9 – Wiper Arm

20. Working on the front right side of the windshield base trim (1a), release the hood opening cable (1b) from the retainer (1c) (Figure 10).

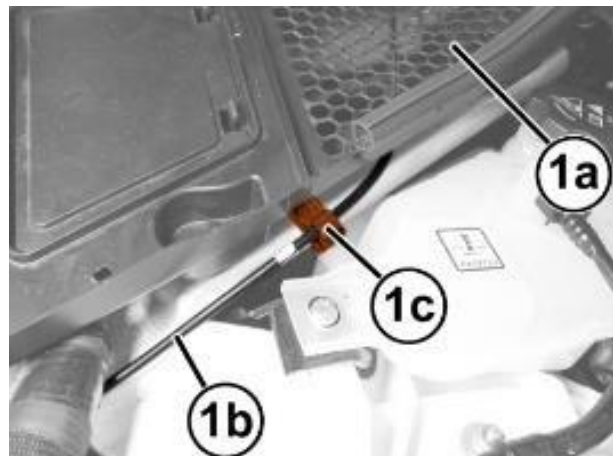
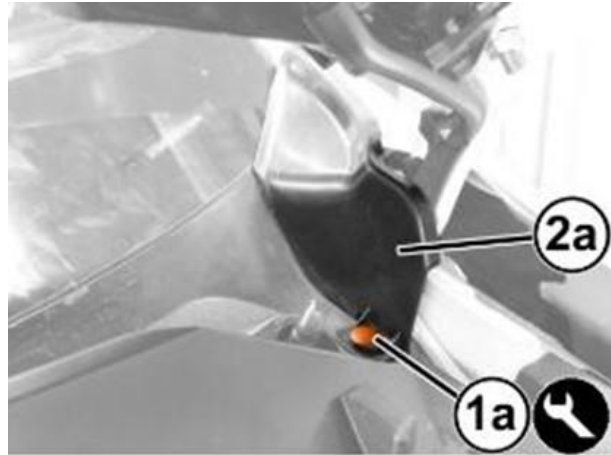

Figure 10 – Hood Opening Cable

Service Procedure [Continued]

- 21. Working on both sides of the windshield base trim, remove the retaining button (1a) after releasing its central pin using the appropriate tool Trim Stick C-4829A (1823015000) (Figure 11).



- 22. Remove the side moldings (2a) by releasing retainers (2b) (Figure 11).



Figure 11 – Windshield Trim

- 23. Working on both sides of the windshield base trim, remove the retaining button (1a) after releasing its central pin using the appropriate tool Trim Stick C-4829A (1823015000) (Figure 12).

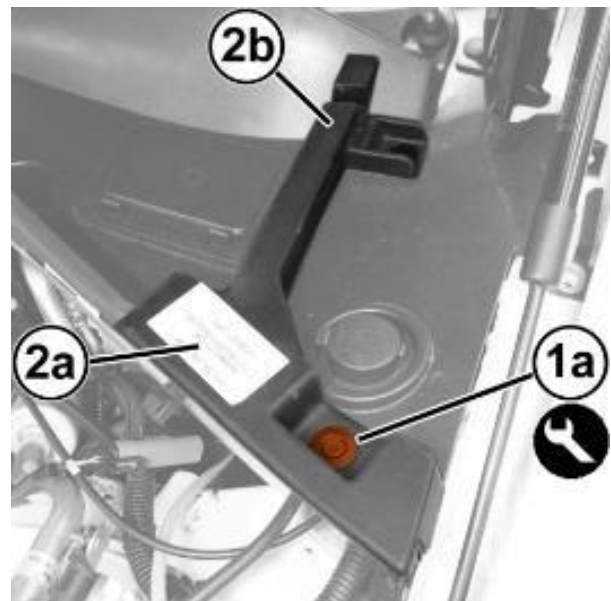

- 24. Lift and move the front (2a) of the side profiles (2b) out of the way, to access the mountings under the windshield trim (Figure 12).

Figure 12 – Side Profile

Service Procedure [Continued]

25. Remove the retaining buttons (1a) from the windshield trim (1b), after releasing their central pins using the appropriate tool Trim Stick C-4829A (1823015000) (Figure 13).

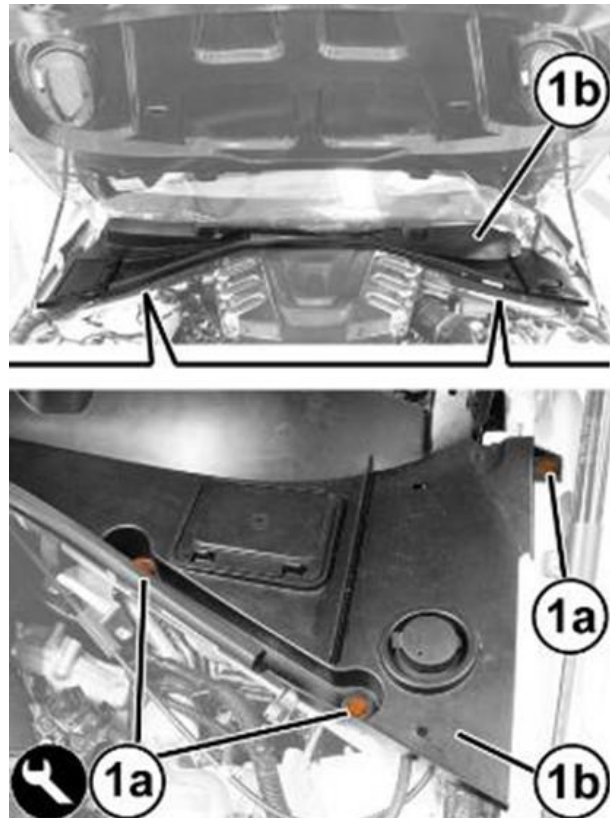

Figure 13 – Windshield Trim

26. Starting from one end (1a) gradually release the windshield base trim (1b) from the retainer profile (1c) along the windshield base (1d) (Figure 14).

CAUTION: Work carefully to avoid damaging the windshield (1d) and the profile (1c) (Figure 14).

27. Keep the windshield base trim (1b) (Figure 14).

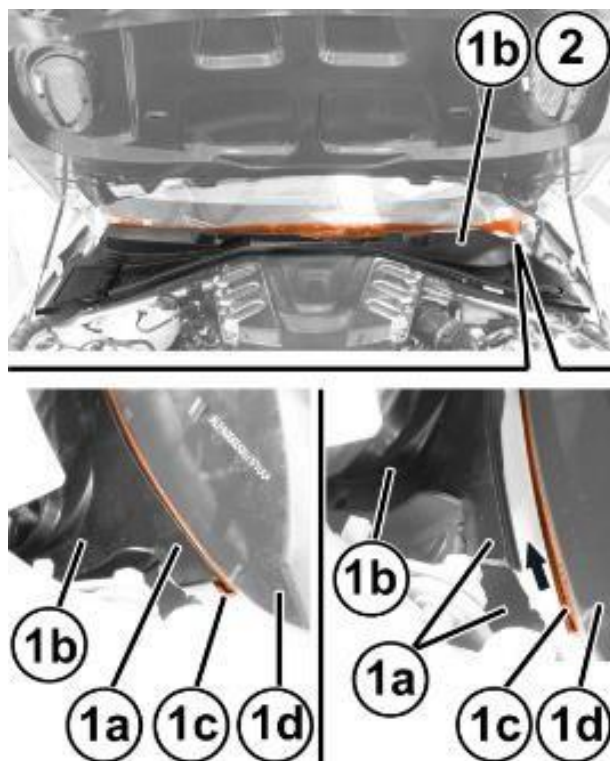

Figure 14 – Windshield Trim

Service Procedure [Continued]

28. Remove the screws (1a) and remove the left body reinforcement (1b) (Figure 15).

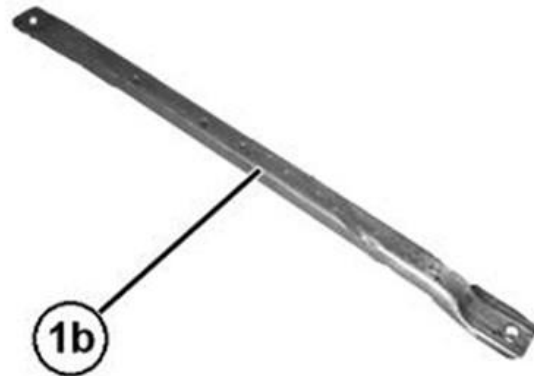
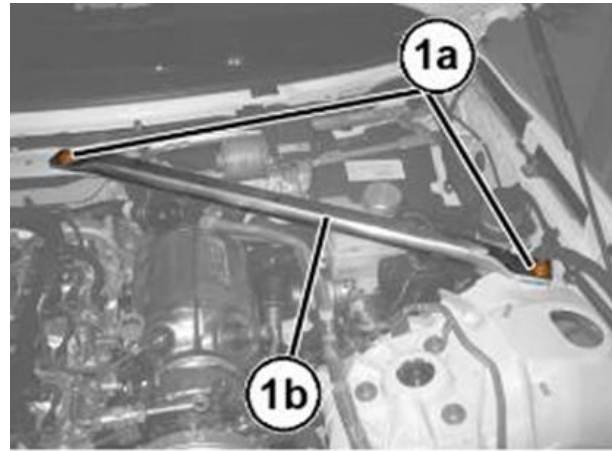

Figure 15 – Body Reinforcement

29. Remove the brake/clutch fluid reservoir plug and install the Master Cylinder Cap tool 2000001400.

CAUTION: It is not necessary to drain the brake system to detach the ABS module. Failure to observe this requirement may mean replacing the brake calipers.

Service Procedure [Continued]

- 30. Disconnect the electrical connection (1) for the ABS module (Figure 16).

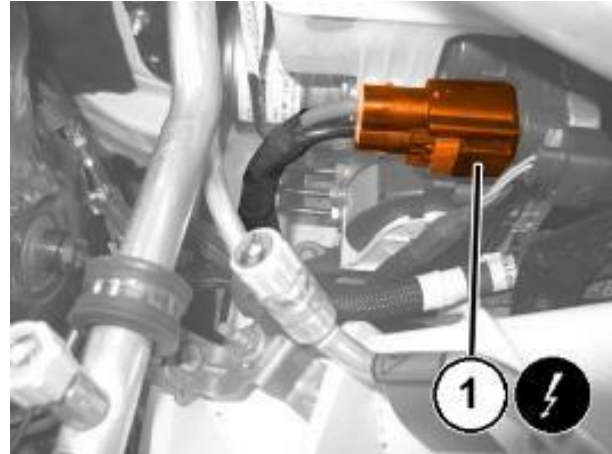

Figure 16 – ABS Electrical Connector

- 31. Disconnect the electrical connection (1) for the ABS module (Figure 17).

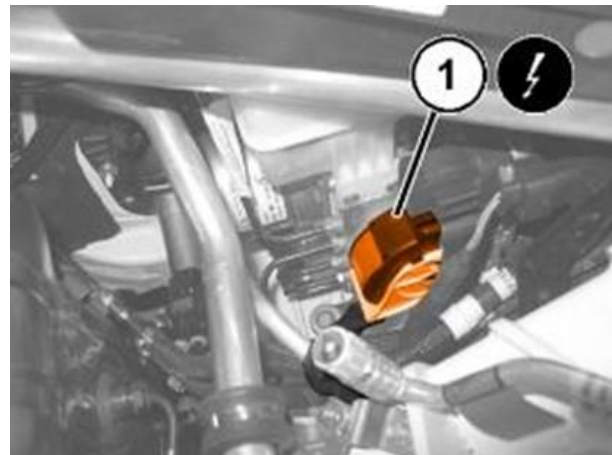

Figure 17 – ABS Electrical Connector

- 32. Remove the connectors (1a) and disconnect the brake fluid pipes (1b) from the ABS module (Figure 18).

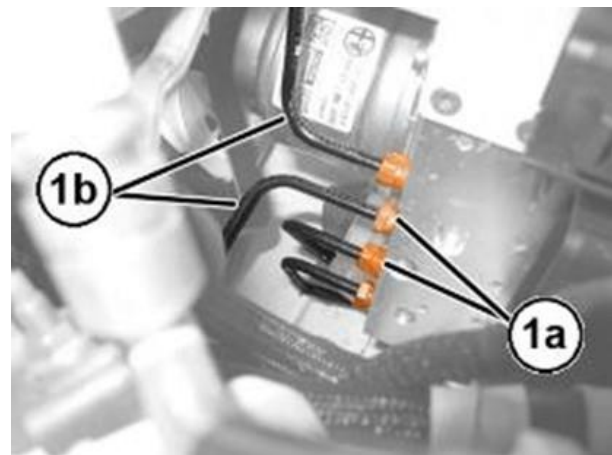

Figure 18 – Brake Fluid Pipes

Service Procedure [Continued]

33. Remove the attaching screw (1) of the ABS control module mounting bracket to the body (Figure 19).

NOTE: To facilitate the subsequent removal of the ABS control module, we advise loosening the screws attaching the aforementioned bracket to the ABS module first.

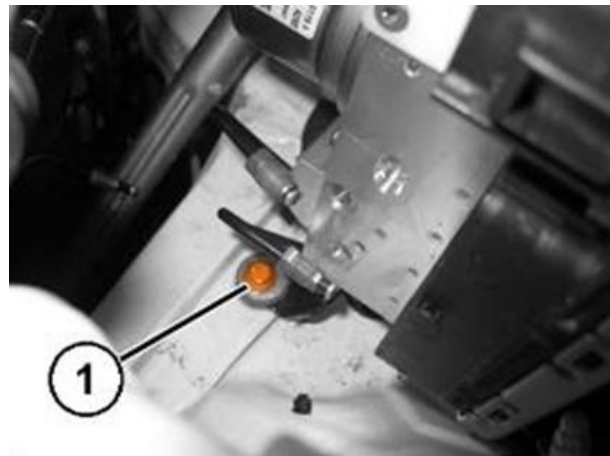

Figure 19 – ABS Mounting Bracket

34. Using the brake switch pliers 2000010500 (1a) positioned on the rear part of the holes (1b) of the brake pedal, compress the retaining device (1c) and retract the brake pedal (1d) at the same time in order to release the pedal from the ABS module push rod (Figure 20).

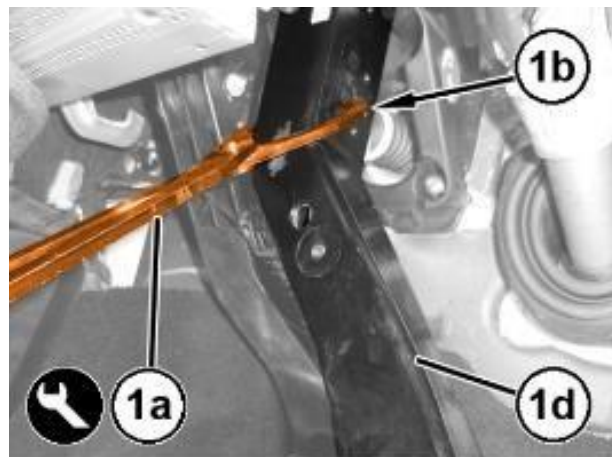

Figure 20 – Brake Pedal Retainer

Service Procedure [Continued]

35. Remove the cup (1a) and the retaining device (1b) from the push rod of the ABS module (1c) (Figure 21).

NOTE: The retaining device must be replaced whenever the push rod is disconnected.

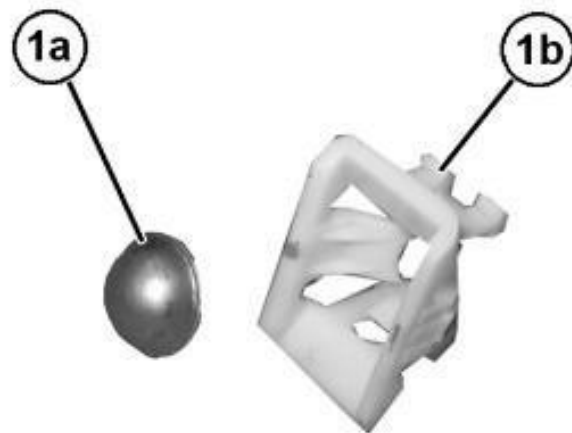
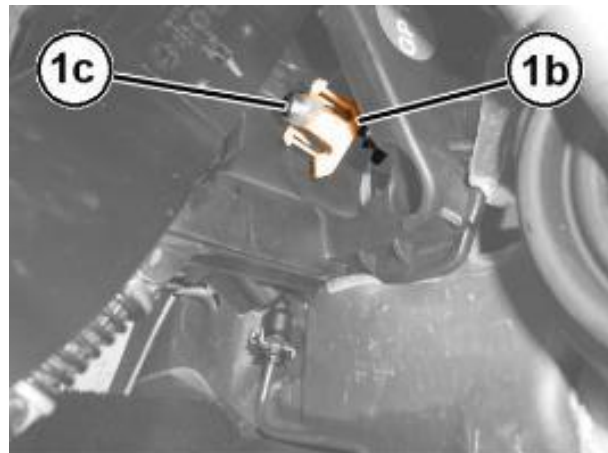

Figure 21 – Brake Pedal Retainer

36. Remove the nuts (1) attaching the ABS module to the pedal unit mounting (Figure 22).

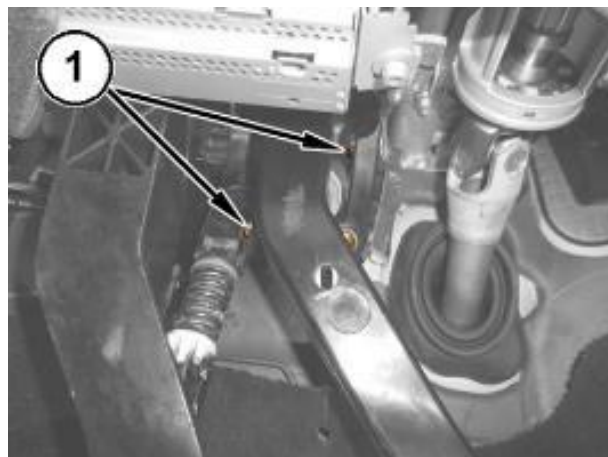

Figure 22 – ABS Module Nuts

Service Procedure [Continued]

37. Retract the ABS module (1a) and remove it releasing the push rod (1b) from the firewall (Figure 23).

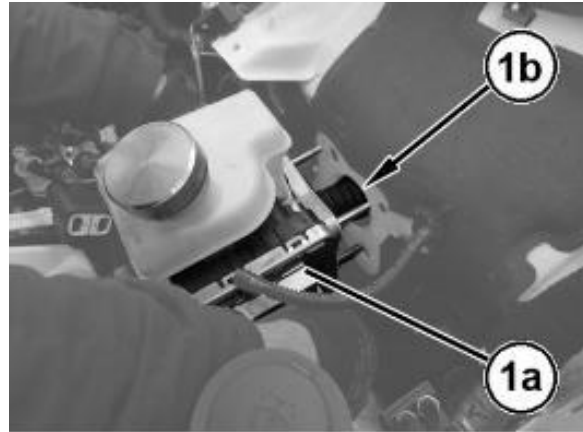

Figure 23 – ABS Module

38. Remove the screw (1a) and remove the ABS control module support bracket (1b) (Figure 24).

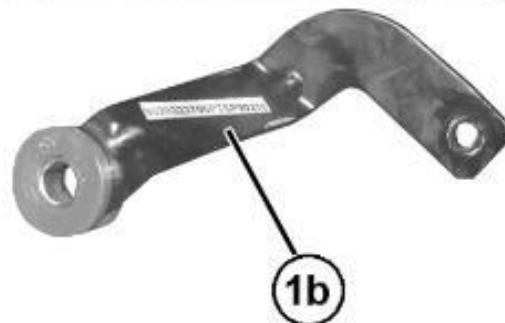
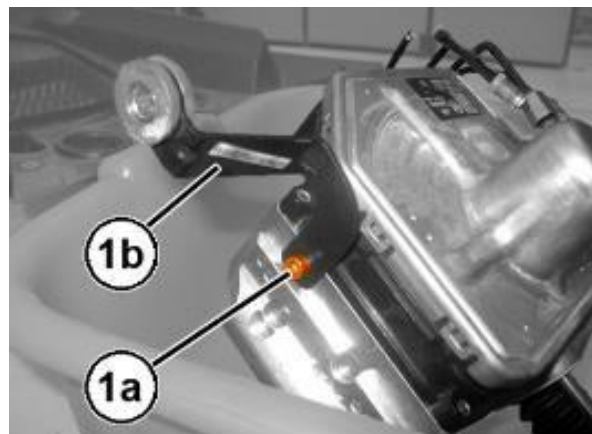

Figure 24 – ABS Module Support

Service Procedure [Continued]

39. Apply suitable silicone grease to the convex part of the cup and position it in place on the brake pedal.
40. Insert the **NEW** retaining device in the brake pedal, engaging the side clips.
41. Install the ABS control module support bracket in position and fasten with the respective attaching screw without tightening it.
42. Position the **NEW** ABS control module, with **NEW** gasket to the bulkhead then start four **NEW** mounting nuts.
43. Tighten the ABS control module **NEW** mounting nuts to the prescribed torque of 22 N·m (16 ft. lbs.).
44. Fasten and tighten the attaching screw of the ABS control module mounting bracket, on body side.
45. Tighten the screw attaching the ABS control module mounting bracket, on the ABS control module side.
46. Connect the brake fluid pipes to the ABS module, starting from the lower one and tighten the connectors manually to engage the thread correctly. Tighten the pipes to 16 N·m (12 ft. lbs.).

NOTE: The pipe ends must be aligned and perfectly perpendicular with respect to their seats to ensure that the connectors screw on correctly.

47. Apply suitable silicone grease to the push rod of the ABS module.
48. Align the ABS control unit pushrod to the brake pedal then press the brake pedal until the pushrod engages the retaining device.

Service Procedure [Continued]

49. Install the left body reinforcement in its position and tighten the attaching screws.
50. Engage the wiring retaining clip on the body pin.
51. Connect the electrical connections of the ABS module.
52. Connect the electrical connection for the brake/clutch fluid level sensor.
53. Position the windshield base trim (1a) in position and engage the retaining profile (1b) along the entire windshield base (1c) (Figure 25).

NOTE: If necessary, use soapy water to facilitate inserting the trim (1a) into the retaining profile (1b) (Figure 25).

CAUTION: Do not press the trim (1a) excessively into the retaining profile (1b) to avoid damaging the windshield.

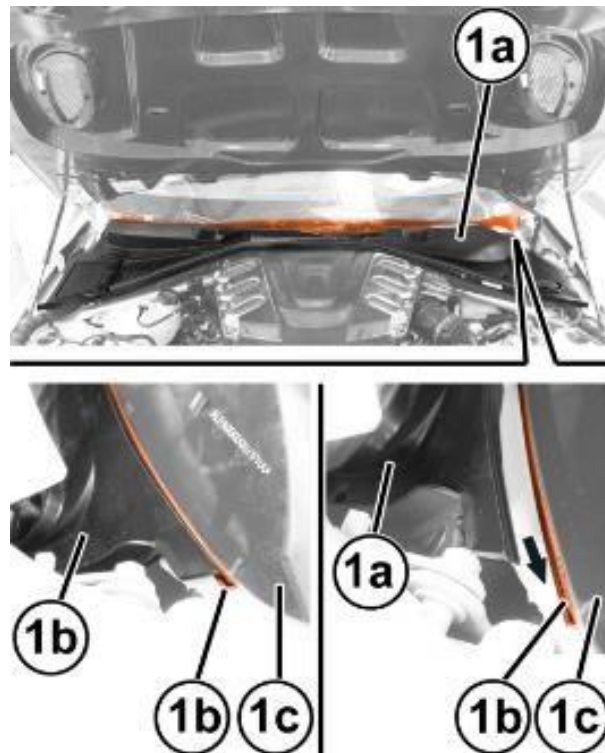

Figure 25 – Windshield Trim

Service Procedure [Continued]

54. Position the windshield base trim (1a) in position and engage the retaining profile (1b) along the entire windshield base (1c) (Figure 26).

NOTE: If necessary, use soapy water to facilitate inserting the trim (1a) into the retaining profile (1b) (Figure 26).

CAUTION: Do not press the trim (1a) excessively into the retaining profile (1b) to avoid damaging the windshield (Figure 26).

55. Apply the retaining buttons (2a) with central pin (Figure 26).
56. Tighten the screw (3a) (Figure 26).
57. Working on the right side of the windshield frame trim, tighten the attaching screws.

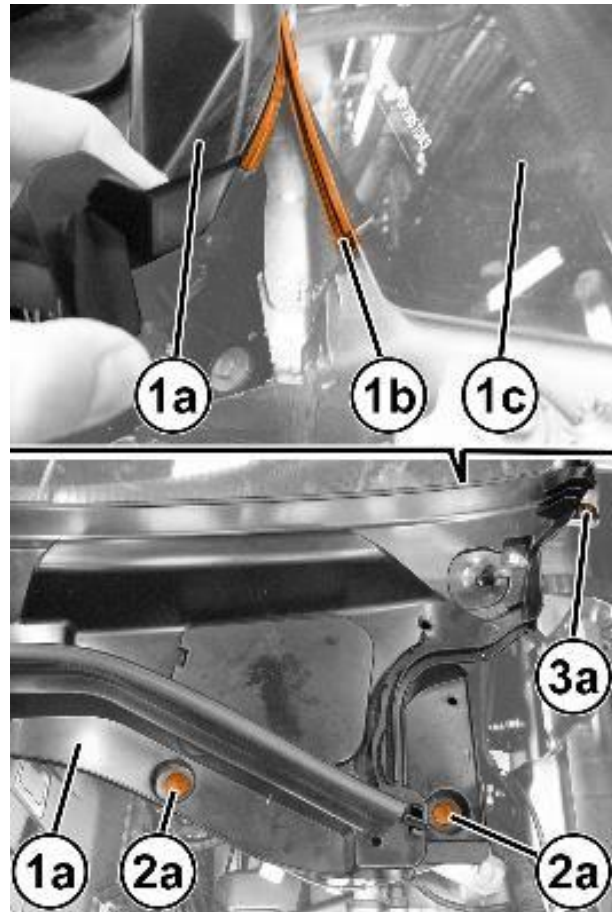

Figure 26 – Windshield Trim

58. Position the side profiles and secure them with their retaining buttons.
59. Position the side moldings and engage them, then secure them with their retaining buttons.
60. Engage the hood opening cable to the retainer.

Service Procedure [Continued]

61. Place the windshield wiper arm (1a) in position aligning the blade (1b) with the references (1c) etched on the windshield (Figure 27).



62. Insert the washer (1a) and tighten the nut (1b) to the prescribed torque of 29 N·m (21 ft. lbs.) (Figure 28).

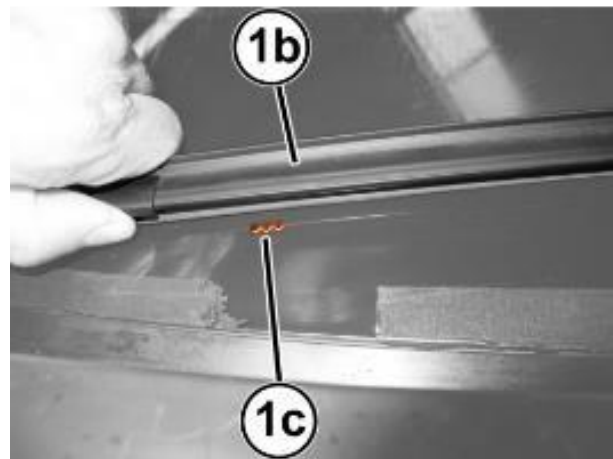

Figure 27 – Wiper Arm

63. Open the hood and put the soundproofing cover back in its housing engaging the retaining pins.

64. Check that the air vent is correctly positioned in its housing, then engage the retaining button with central pin.

65. Take the lower trim and connect the electrical connections to the courtesy lights.

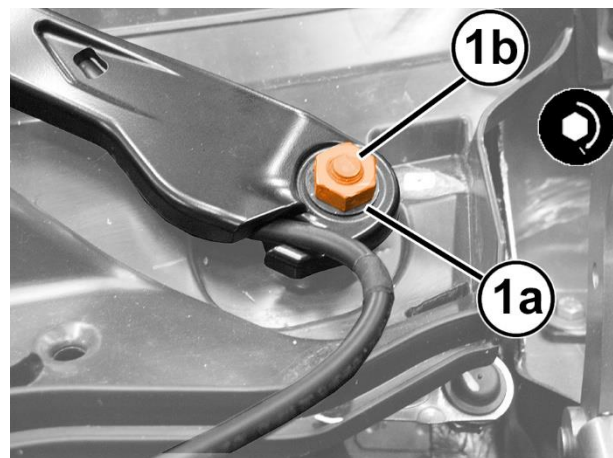

Figure 28 – Wiper Arm

66. Position the lower trim, engaging the retainers and fastening the attaching screws.

67. Position the console side closure and engage its inner retainers.

Service Procedure [Continued]

68. Bleed air from the hydraulic brake system as described in the following steps:
69. Remove the wheel studs then remove the front and rear wheels.

CAUTION: Replace the fluid in the pressure bleeder with NEW fluid meeting the specification DOT4 MS.90039.

70. Connect the bleeding equipment (1) to the brake fluid reservoir and pressurize the system (Figure 29).

NOTE: The operating pressure must be kept at 2 - 3 bar (29 - 43 psi) during the “First stage” and “Second stage” described below.



Figure 29 – Bleeding Equipment

71. Working at the right front caliper, position the brake fluid recovery hose to the INNER bleeder screw (1) and to the recovery container. Open the INNER bleeder screw (1) and without applying any pedal pressure on the system, allow a small amount of brake fluid to drain into the recovery container. Then tighten the bleeder screw and remove the recovery hose (Figure 30).

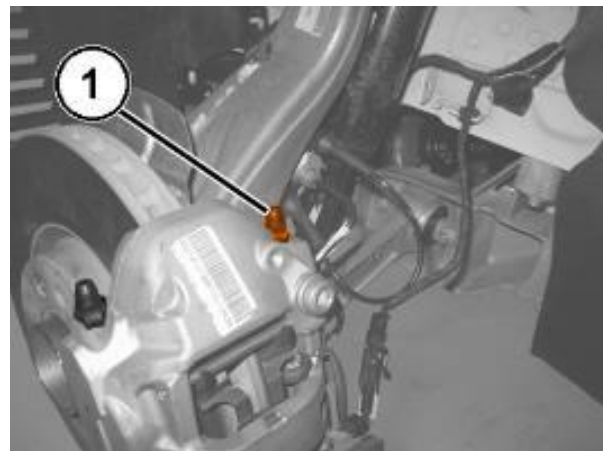

Figure 30 – Brake Bleeder Valve

72. Repeat the above operation on the left front brake caliper.

Service Procedure [Continued]

73. Working at the right rear caliper, position the brake fluid recovery hose to the bleeder screw (1) and to the recovery container. Open the bleeder screw (1) and without applying any pedal pressure on the system, allow a small amount of brake fluid to drain into the recovery container. Then tighten the bleeder screw and remove the recovery hose (Figure 31).

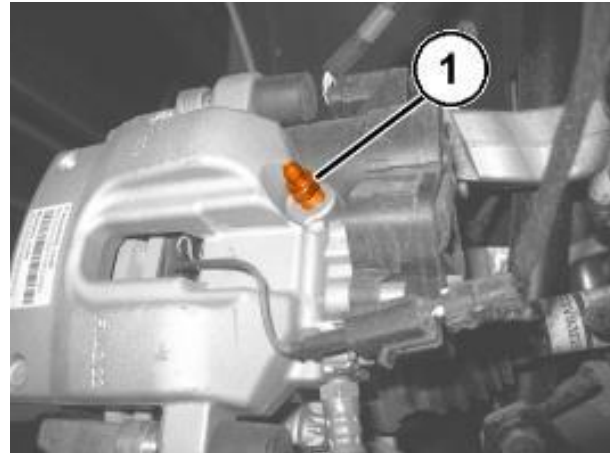

Figure 31 – Brake Bleeder Valve

74. Repeat the procedure for the left rear caliper.
75. Working at the left front caliper, position the brake fluid recovery hose to the INNER bleeder screw (1) and to the recovery container. Open the bleeder screw and slowly press the brake pedal down fully three or more times, until there are no more air bubbles in the recovery hose. Then tighten the bleed valve to the prescribed torque of 10 N·m (89 In. lbs.) (Figure 30).
76. Repeat the bleed procedure on the OUTER bleeder screw of the left front caliper.
77. Repeat the above operation on the left front brake caliper.
78. Connect the pipe to the valve of the rear right brake caliper. Open the valve, slowly press the brake pedal down fully three or more times, until there are no more air bubbles in the hose through which the oil flows into the container. Tighten the bleed valve to the prescribed torque of 10 N·m (89 In. lbs.) (Figure 31).
79. Repeat the above operation on the rear left brake caliper.

Service Procedure [Continued]

- 80. Connect the terminal to the dummy negative pole of the battery and check that the retainer is correctly coupled. Connect the IBS connector if equipped.
- 81. Connect the wiTECH diagnosis equipment to the vehicle data link connector of the vehicle, go to the ABS control module in the “**Miscellaneous Functions**” menu and start the “**Replace Control Module**” and “**Check Air Presence in Hydraulic System Between Control Module and Brake Caliper**” procedure.
- 82. Check that the value of FL - FR - RR - RL volumes shown on the diagnostics equipment are within the ranges shown in the table:

VERSION	200 HP		280 HP	
	MIN	MAX	MIN	MAX
FL (mm3)	1440	2550	1495	2755
FR volume (mm3)	1625	2735	1790	3050
RR volume (mm3)	870	1990	870	1990
RL volume (mm3)	855	1975	855	1975

- 83. If even only one of the values shown in the aforementioned table is higher than the reference threshold, repeat the bleeding procedure as instructed by the diagnosis equipment.
- 84. If after repeating the bleeding procedure, the maximum values for the rear calipers are still higher than the limit values, proceed as described below on the rear calipers only.
- 85. Find the out of tolerance caliper and remove it without disconnecting the hose.
- 86. Turn the brake caliper very slowly several times to the various possible positions, stop the motion and keep the bleed valve pointing upwards for a few minutes.



Figure 32 – Rotate Caliper

Service Procedure [Continued]

87. Install the brake caliper(s), then repeat the bleeding steps for the caliper(s) and check the volumes using the diagnosis equipment.
88. Position the right side flap of the battery housing and engage the retainers.
89. Check the operation of the electrical system.
90. Check that the time/day etc. are correct.
91. Close the hood.
92. Check the operation of the windshield wiper.
93. Reposition the luggage compartment lid opening cord in its housing and close the cap.
94. Close the luggage compartment lid.
95. The steering must be initialized after the battery has been disconnected. This will be indicated by a warning light on the instrument panel turning on. To carry out this procedure, just start the engine, turn the steering wheel from one lock to the other and put it back into the center position.
96. Enable automatic electric handbrake engagement when the engine stops. Connect the wiTECH diagnosis equipment to the vehicle data link connector of the vehicle, select ABS “**Miscellaneous Functions**”, select “**Electric Park Brake (EPB)**” then start the “**Assembly Check**” procedure.
97. From the Connect system, switch automatic handbrake enable from **ON > OFF** and immediately after from **OFF > ON**.
98. Remove the car from the lift.

Service Procedure [Continued]

B. (GA) Alfa Romeo Giulia with EEC-2.9L engine.

1. Position the vehicle on a suitable hoist.
2. Perform the electric handbrake disengagement procedure. Connect the wiTECH diagnosis equipment to the vehicle data link connector of the vehicle, select Antilock Brake System (ABS) in the “**Miscellaneous Functions**” select “**Electric Park Brake (EPB)**”, then start the “**Maintenance Mode**”.

NOTE: If the ABS control module is replaced, connect the wiTECH diagnosis equipment to the vehicle data link connector, go to "ABS control module" and start the "Control module replacement" procedure.

3. Drain the refrigerant using an R-1234yf refrigerant recovery recycling charging station that meets SAE standard J2843.
4. Let the engine run with the climate control system on for 10 - 15 minutes.
5. Depending on the vehicle engine type, remove/move any parts that hinder connection of the pipes of the refrigerant recovery recycling charging station (1a) to the corresponding climate control system re-pressurizing valves (1b) and (1c) (Figure 33).
6. Unscrew the re-pressurizing valve caps (1b) and (1c) (Figure 33).

Service Procedure [Continued]

7. Connect the high pressure connecting pipe (**HIGH**) of the device to the corresponding quick coupling valve (1b) (Figure 33).

NOTE: To engage the connectors (3a) on the quick coupling valves, move the knurled ring nut (3b) upward. Fasten the ring nuts (3c) after insertion (Figure 33).



8. Connect the low pressure connecting pipe (**LOW**) to the corresponding quick coupling valve (1c) (Figure 33).

NOTE: To improve safety the quick couplings (3a) for the equipment connecting pipes have different diameters: the low pressure side is larger, while the high pressure side is smaller (Figure 33).

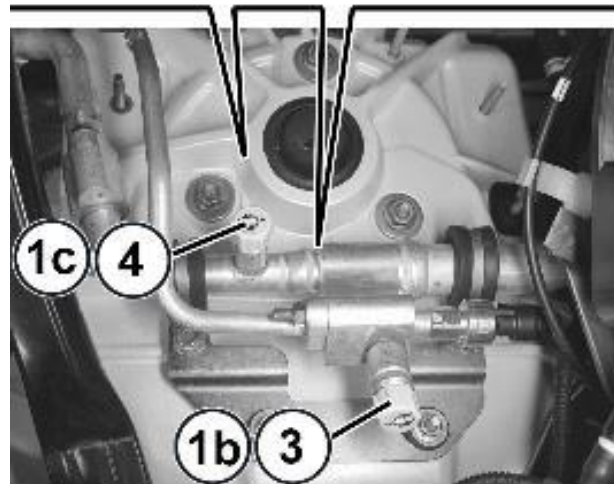

9. Start the procedure for draining the coolant fluid, following the instructions in the equipment manual. Save the coolant, it is to be reused.



Figure 33 – Climate Control System

Service Procedure [Continued]

10. When draining the system, the compressor oil extracted collects in a special container (1) (Figure 34).

CAUTION: The oil is very hygroscopic: do not leave the containers open.



Figure 34 – Compressor Oil

11. Raise the door windows to the upper end of travel position.

NOTE: Disconnecting the battery when the windows are in a position other than the upper end of travel will entail the need to run the window end of travel learning procedure.

12. Open the luggage compartment lid and support it so it will not close.

NOTE: If the luggage compartment lid closes while the battery is disconnected, it will not be possible to reopen it. The rear seat may need to be removed to gain access to the luggage compartment area.

Service Procedure [Continued]

13. To be able to reopen the luggage compartment lid, even if it accidentally closes with the battery disconnected, before disconnecting the battery, it is necessary to unscrew the cap (1b), release the pull cord hooked onto it and leave it hanging out of the luggage compartment. Then, by working on the pull cord, an emergency luggage compartment lid lock release can be obtained. The pull cord operates on the lever (1a) inside (Figure 35).

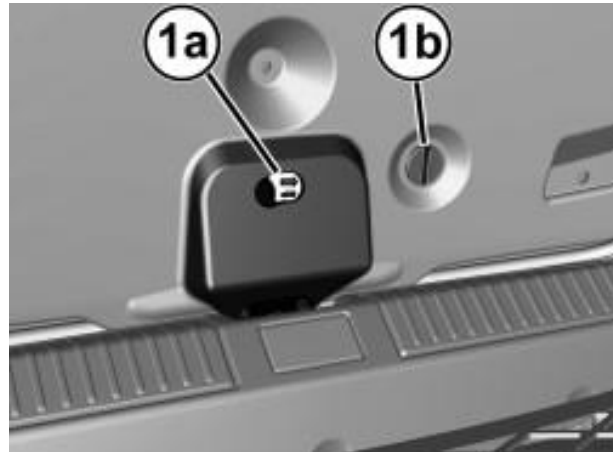

Figure 35 – Lid Lock Release

14. The ignition must be in the OFF position and the vehicle must remain powered down for at least 1 minute prior to proceeding.

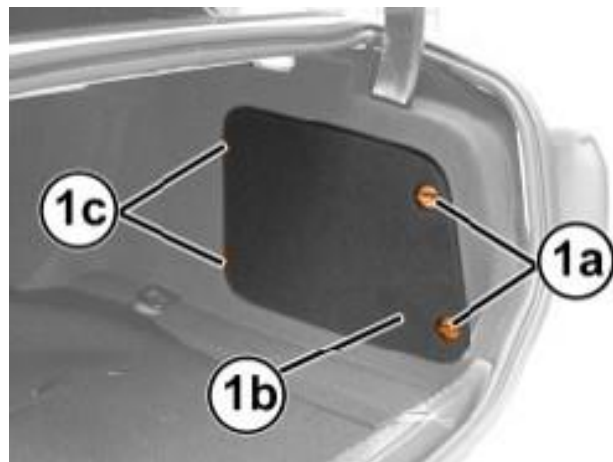

Figure 36 – Battery Cover

15. Remove the battery cover (1b) by releasing retainers (1a) (Figure 36).

16. If equipped with an Intelligent Battery Sensor (IBS), disconnect the IBS connector.

17. Press the retainer (1a) and disconnect the terminal (1b) from the “negative dummy terminal” (1c) of the battery (1d) (Figure 37).



Figure 37 – Battery Negative Cable

18. Move the terminal out of the way and isolate it (1b) (Figure 37).

Service Procedure [Continued]

19. Remove the console side closure (1a), by disengaging the various inner retainers (1b) using the appropriate tool Trim Stick C-4829A (1823015000) (Figure 38).

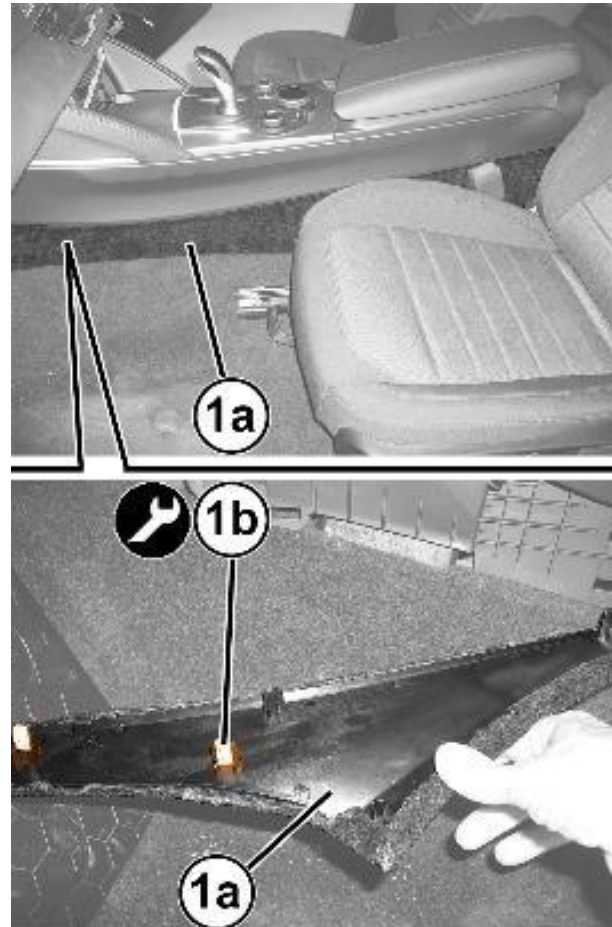

Figure 38 – Console Side Closure

Service Procedure [Continued]

20. Remove the screws from the housings (1a) of the bottom trim (1b) (Figure 39).

21. Release the retaining button from the housing (2a), using the special tool Trim Stick C-4829A (1823015000) (Figure 39).

22. Pull down the bottom trim (1b) by releasing the inner retainers (3a) (Figure 39).

23. Disconnect the electrical connection (4a) for the courtesy lights on the bottom trim (Figure 39).

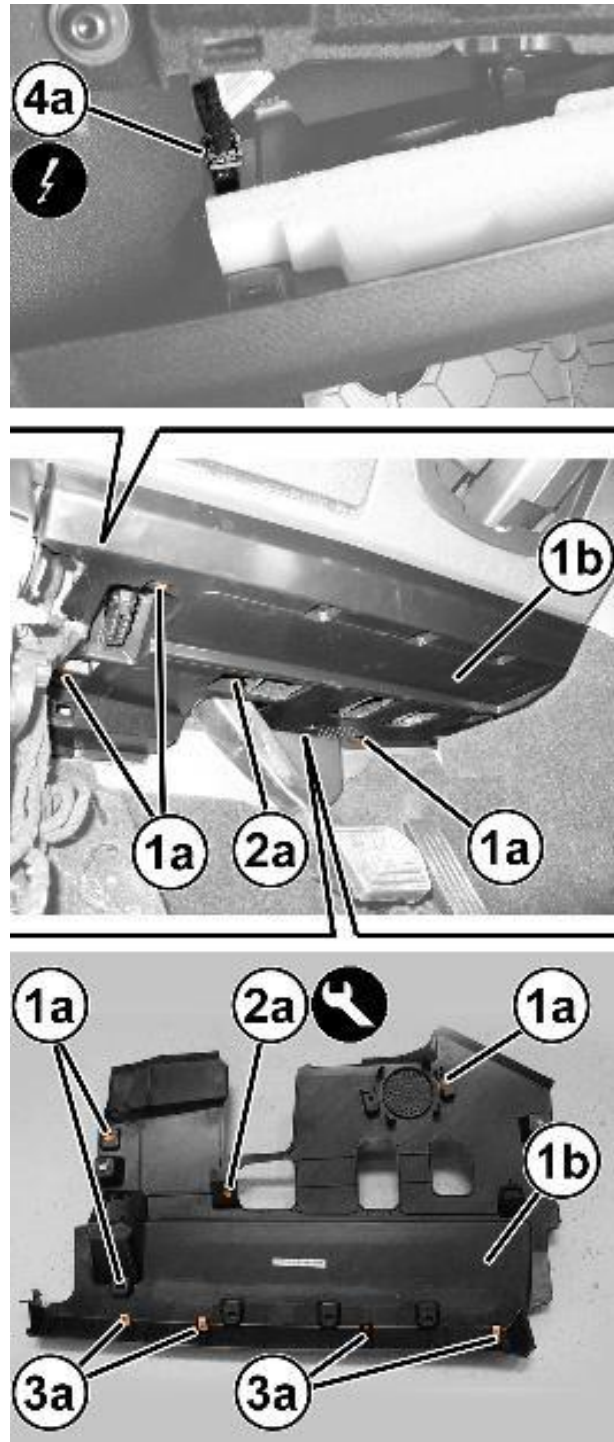

Figure 39 – Bottom Trim

Service Procedure [Continued]

24. Use tool Trim Stick C-4829A (1823015000) to disconnect the retaining pin with central pin (1a) and release the air vent (2a) (Figure 40).

CAUTION: Carefully move the air vent (2a) only when accessing the ABS module fasteners to avoid damaging it (Figure 40).

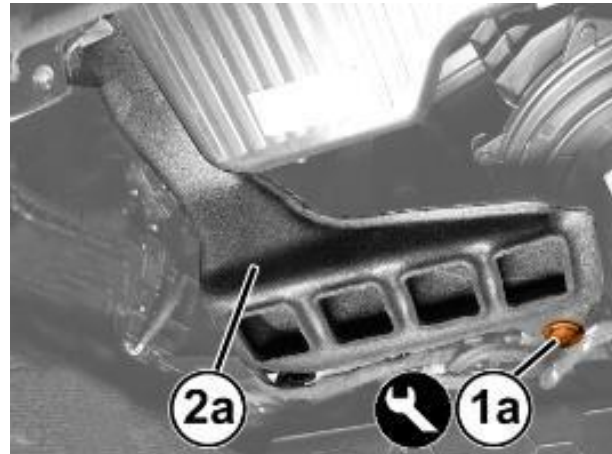

Figure 40 – Air Vent

25. Release the soundproofing cover (1) from the retaining pins and remove it (Figure 41).

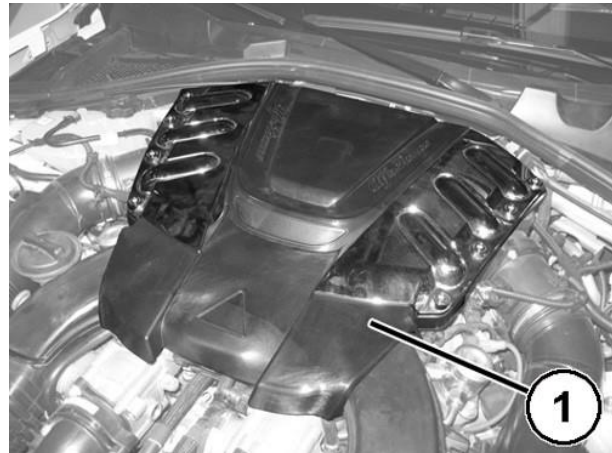

Figure 41 – Soundproofing Cover

26. Open the clip (1a) and disconnect the quick coupling of the degassing pipe (1b) (Figure 42).
27. Loosen the clamp (2a) and disconnect the degassing pipe (2b) (Figure 42).

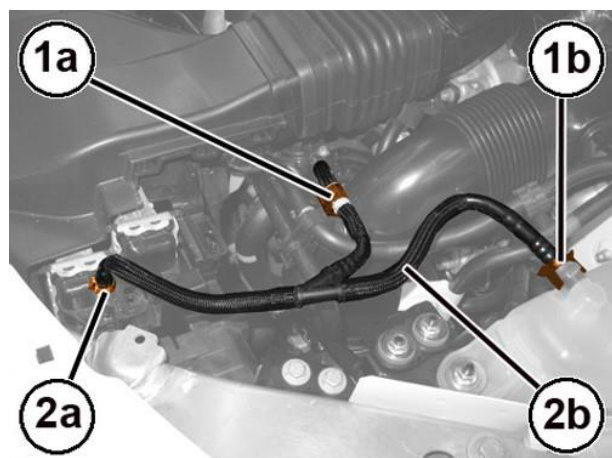

Figure 42 – Degassing Pipe

Service Procedure [Continued]

28. Remove the attaching nuts (1) of the solenoid valve support bracket (Figure 43).

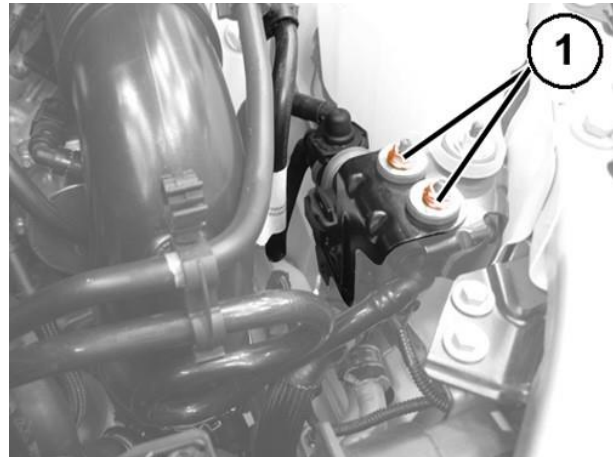

Figure 43 – Solenoid Support Bracket

29. Open the clip (1a) and disconnect the quick coupling (1b) of the fuel vapor supply pipe to the solenoid valve (Figure 44).

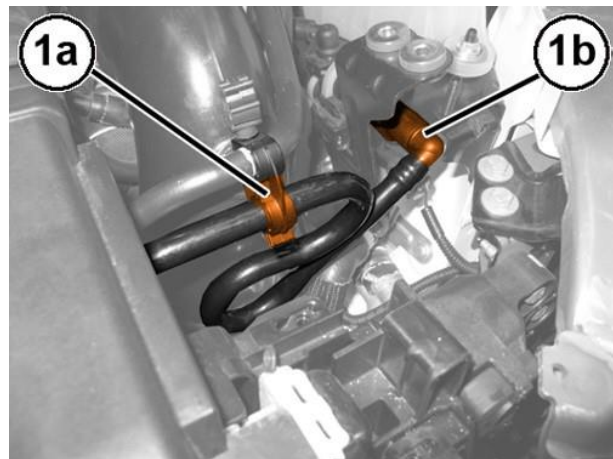

Figure 44 – Fuel Vapor Supply Pipe

Service Procedure [Continued]

30. Disconnect the electrical connection (1) for the solenoid valve (Figure 45).

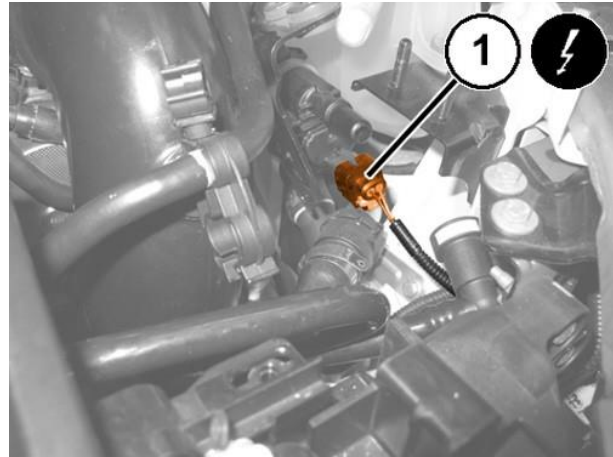

Figure 45 – Solenoid Valve Connector

31. Disconnect the quick coupling (1) of the fuel vapor supply pipe to the air sleeve between air flow meter and heat exchanger (Figure 46).

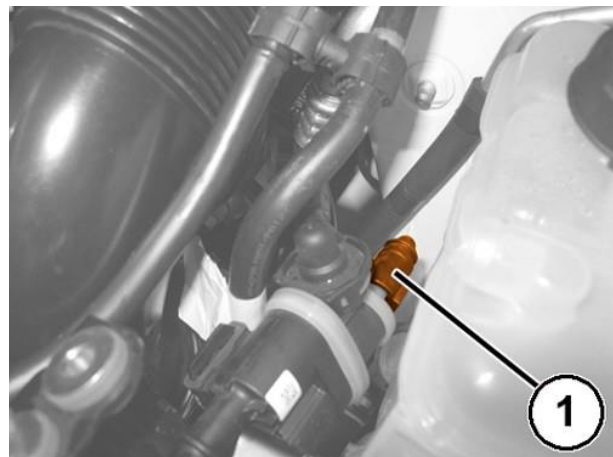

Figure 46 – Fuel Vapor Supply Pipe

Service Procedure [Continued]

32. Work on the clips to disconnect the fuel vapor supply pipe to the intake manifold (1a) and remove the solenoid valve for consent of the fuel vapor passage to the intake (1b) (Figure 47).

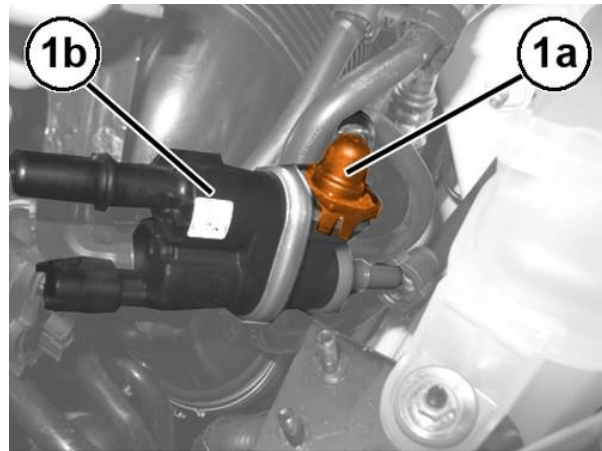

Figure 47 – Solenoid Valve

33. Loosen the clamp (1a) and disconnect the outlet tube (1b) from the air cleaner (Figure 48).

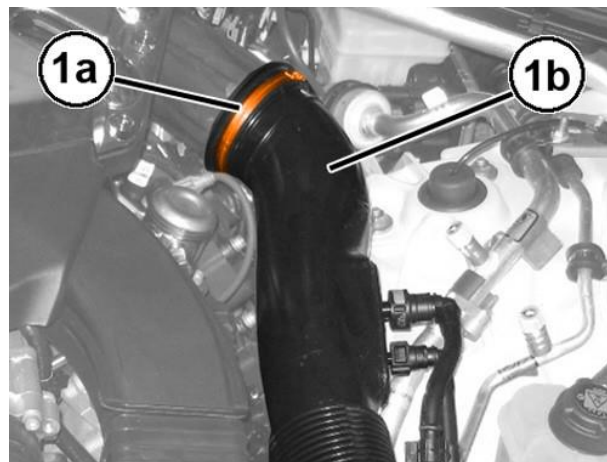

Figure 48 – Air Cleaner Outlet Tube

Service Procedure [Continued]

34. Disconnect the air piping quick coupling (1) between heat exchanger and left turbocharger intake (Figure 49).

35. Disconnect the fuel vapor supply pipe quick coupling (2) to the left turbocharger intake (Figure 49).

36. Loosen the clamp (1) and remove the outlet tube from air cleaner to left turbocharger air inlet pipe (Figure 50).

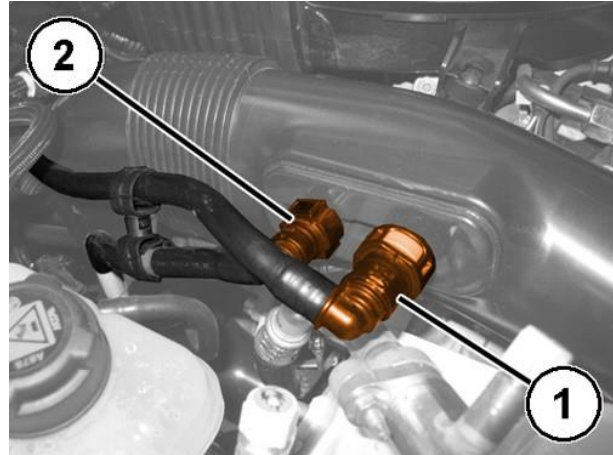

Figure 49 – Air Pipes Coupling



Figure 50 – Air Cleaner Outlet Tube

Service Procedure [Continued]

37. Release the electrical connections (1a) from the bracket (1b) and move it out of the way (Figure 51).

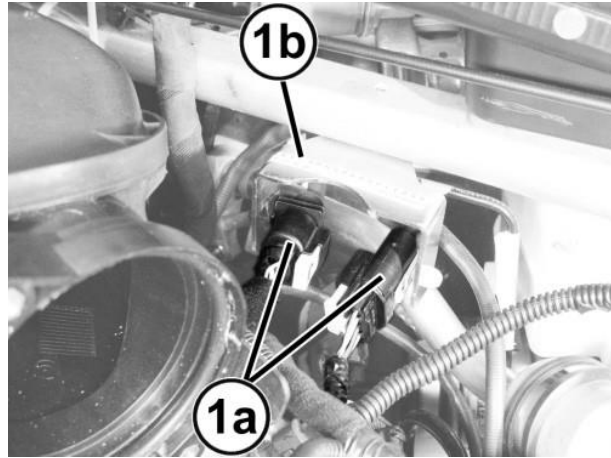

Figure 51 – Electrical Connectors

38. Remove the nut (1a) and disconnect the connector (1b) for the pipe from the expansion valve (1c) (Figure 52).

CAUTION: Seal the disconnected unions with suitable plugs to prevent moisture and impurities from entering the system.

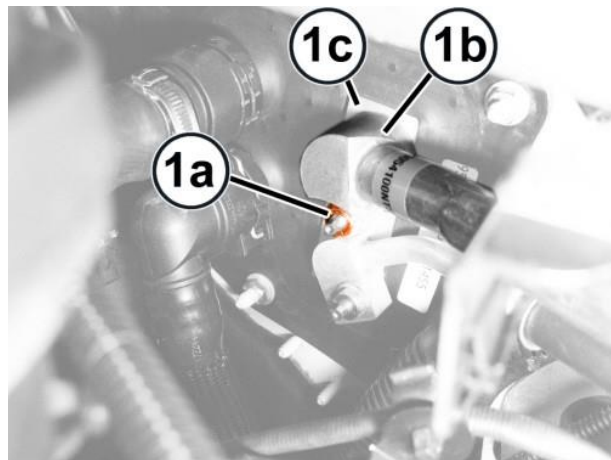

Figure 52 – Refrigerant Pipe

Service Procedure [Continued]

39. Unscrew the attaching nuts and open the retaining straps (1a) from the pipe (1b) to be removed (Figure 53).

40. Remove the nut (2a) and disconnect the connector (2b) from the pipe (1b) (Figure 53).

41. Remove the pipe (1b) (Figure 53).

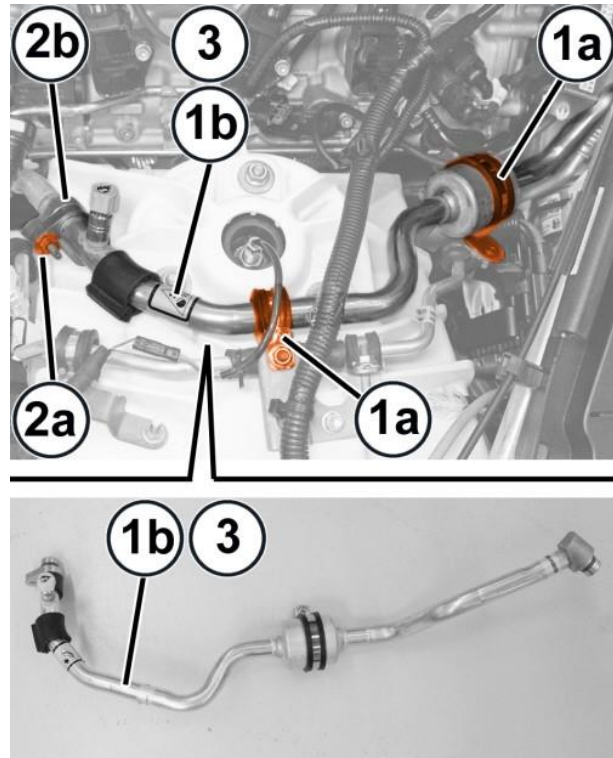

Figure 53 – Refrigerant Pipe

Service Procedure [Continued]

42. Release the nut cover (1) at the base of the windshield wiper arm (Figure 54).



Figure 54 – Wiper Arm Nut Cover

43. Remove the nut (1a) and keep the washer (1b) (Figure 55).
44. Remove the wiper arm (2a) (Figure 55).

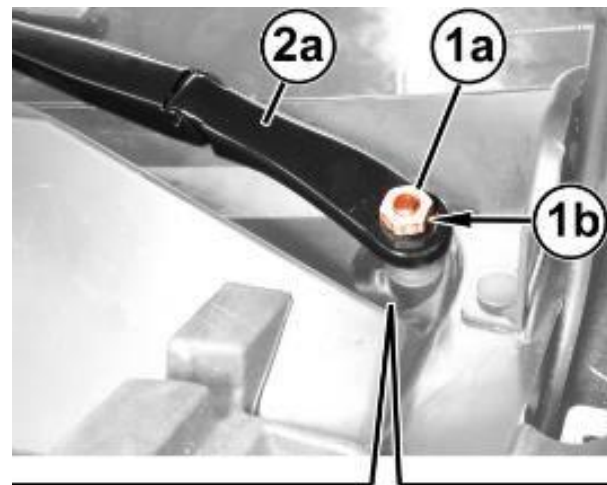

NOTE: If necessary, remove the wiper arm using a suitable extractor to release the ribbed truncated cone coupling (3a) (Figure 55).

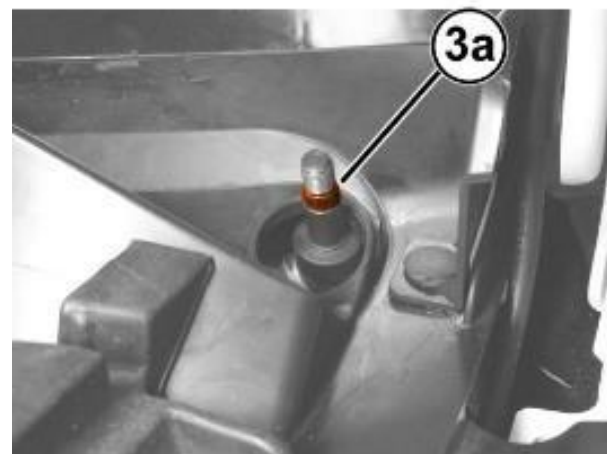

Figure 55 – Wiper Arm

Service Procedure [Continued]

- 45. Working on the front right side of the windshield base trim (1a), release the hood opening cable (1b) from the retainer (1c) (Figure 56).

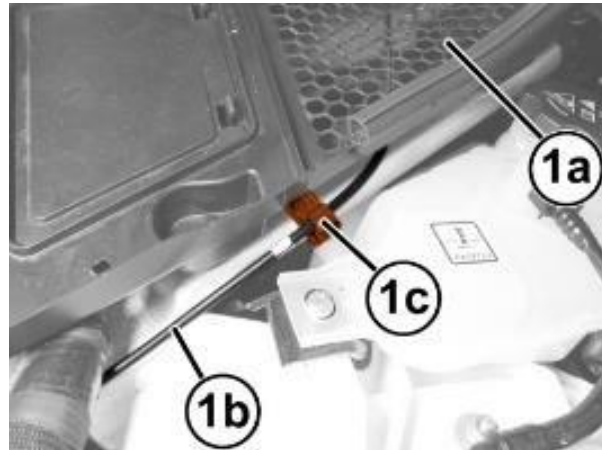
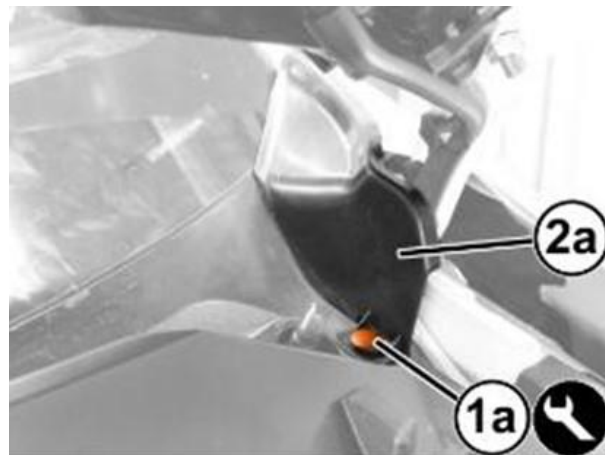

Figure 56 – Hood Opening Cable

- 46. Working on both sides of the windshield base trim, remove the retaining button (1a) after releasing its central pin using the appropriate tool Trim Stick C-4829A (1823015000) (Figure 57).



- 47. Remove the side moldings (2a) by releasing retainers (2b) (Figure 57).



Figure 57 – Windshield Base Trim

Service Procedure [Continued]

48. Working on both sides of the windshield base trim, remove the retaining button (1a) after releasing its central pin using the appropriate tool Trim Stick C-4829A (1823015000) (Figure 58).

49. Lift and move the front (2a) of the side profiles (2b) out of the way, to access the mountings under the windshield trim (Figure 58).

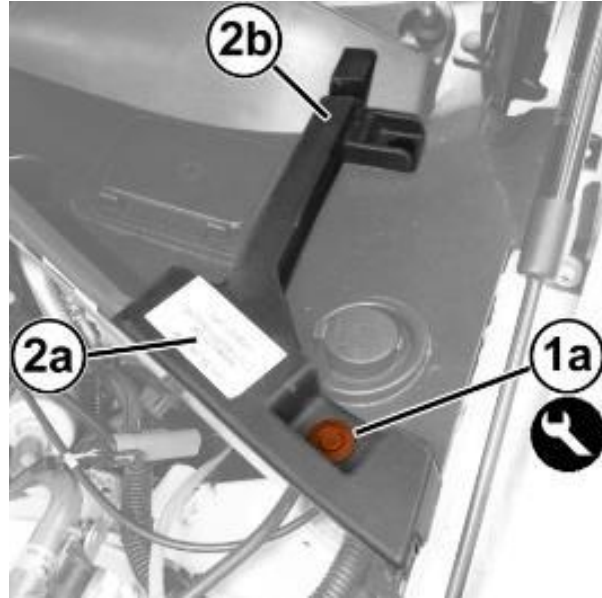

Figure 58 – Windshield Side Profile

50. Remove the retaining buttons (1a) from the windshield trim (1b), after releasing their central pins using the appropriate tool Trim Stick C-4829A (1823015000) (Figure 59).

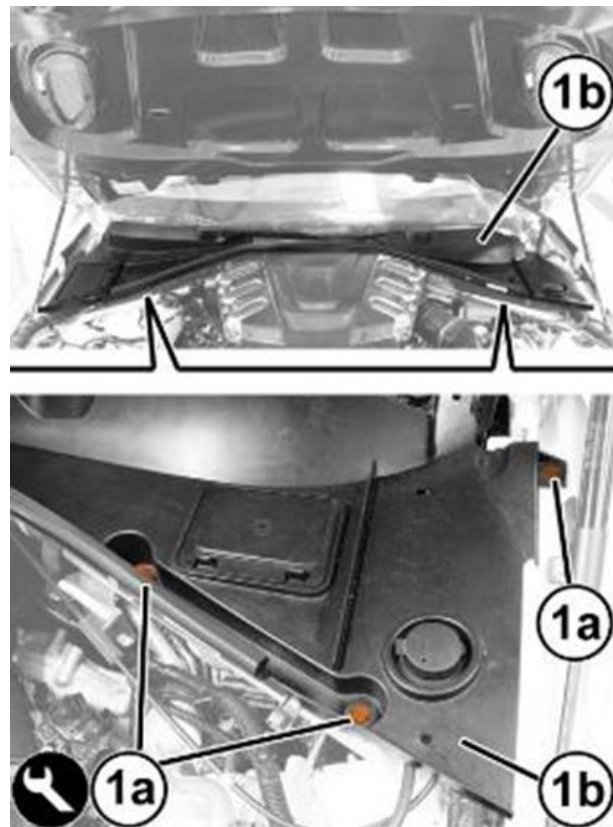
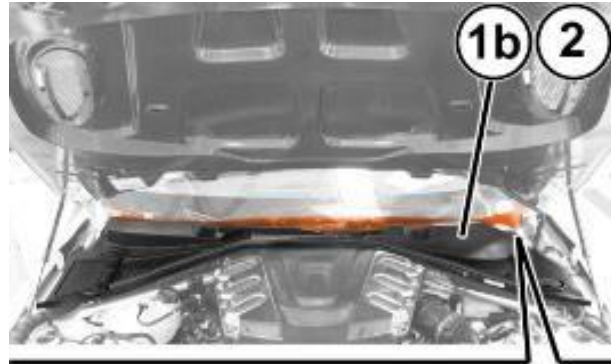

Figure 59 – Windshield Trim

Service Procedure [Continued]

51. Starting from one end (1a) gradually release the windshield base trim (1b) from the retainer profile (1c) along the windshield base (1d) (Figure 60).

CAUTION: Work carefully to avoid damaging the windshield (1d) and the profile (1c) (Figure 60).



52. Keep the windshield base trim (1b) (Figure 60).

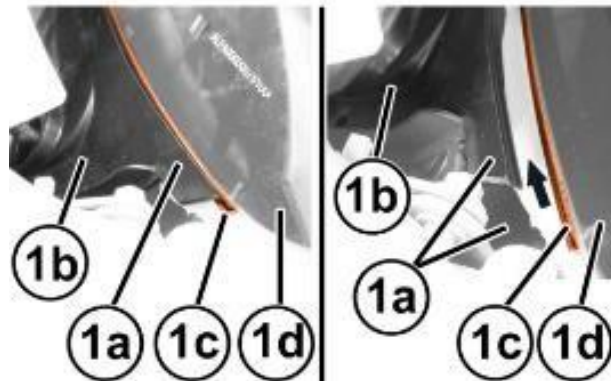

Figure 60 – Windshield Trim

53. Remove the nut (1a) attaching the delivery pipe union (1b) to the condenser (Figure 61).

CAUTION: Seal the disconnected unions with suitable plugs to prevent moisture and impurities from entering the system.

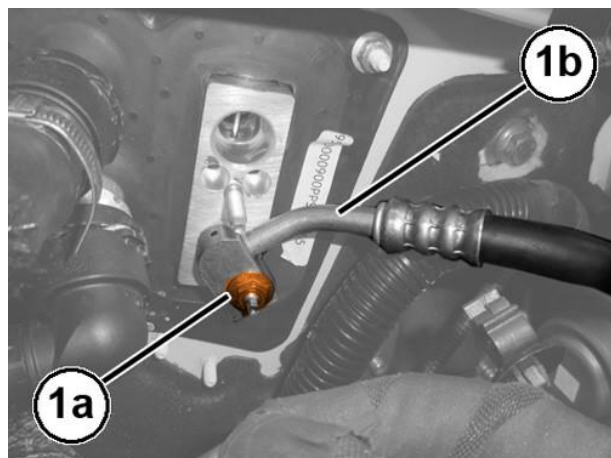

Figure 61 – Refrigerant Pipe

Service Procedure [Continued]

54. Remove the nut (1a) and move the supply pipe to the evaporator (1b) aside (Figure 62).

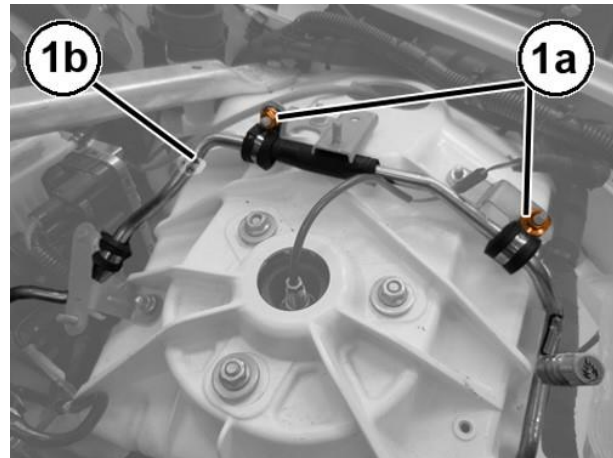

Figure 62 – Refrigerant Pipe

55. Remove the screws (1a) and remove the body reinforcement (1b) (Figure 63).

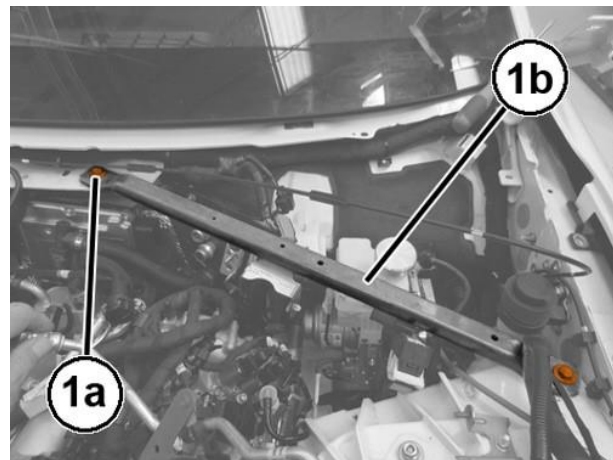

Figure 63 – Body Reinforcement

Service Procedure [Continued]

56. Remove the brake/clutch fluid reservoir plug and attach the tool 2000001400.

CAUTION: It is not necessary to drain the brake system to detach the ABS module. Failure to observe this requirement may mean replacing the brake calipers.

57. Disconnect the electrical connections (1) of the ABS module (Figure 64).

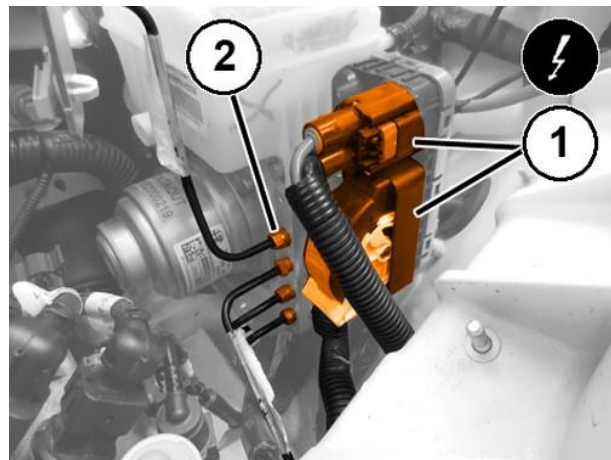

Figure 64 – ABS Module

58. Remove the connectors of the brake oil pipes (2) on ABS module side (Figure 64).

59. Disconnect electrical connection of the brake/clutch fluid level sensor (not shown).

60. Remove the screw (1) attaching the ABS module mounting bracket to the body (Figure 65).

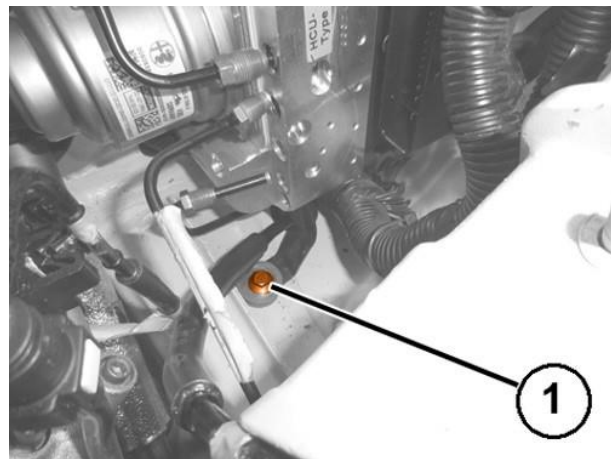

Figure 65 – Mounting Bracket

NOTE: To facilitate the subsequent removal of the ABS control module, we advise loosening the screws attaching the aforementioned bracket to the ABS control module.

Service Procedure [Continued]

61. Using the brake switch pliers 2000010500 (1a) positioned on the rear part of the holes (1b) of the brake pedal, compress the retaining device (1c) and retract the brake pedal (1d) at the same time in order to release the pedal from the ABS module push rod (Figure 66).

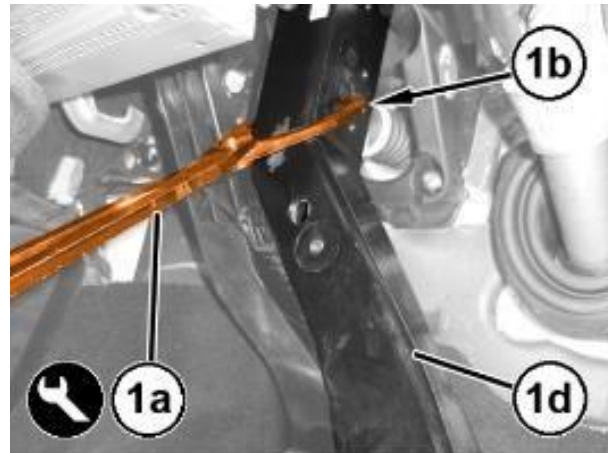

Figure 66 – Brake Pedal Retainer

Service Procedure [Continued]

62. Remove the cup (1a) and the retaining device (1b) from the push rod of the ABS module (1c) (Figure 67).

NOTE: The retaining device must be replaced whenever the push rod is disconnected.

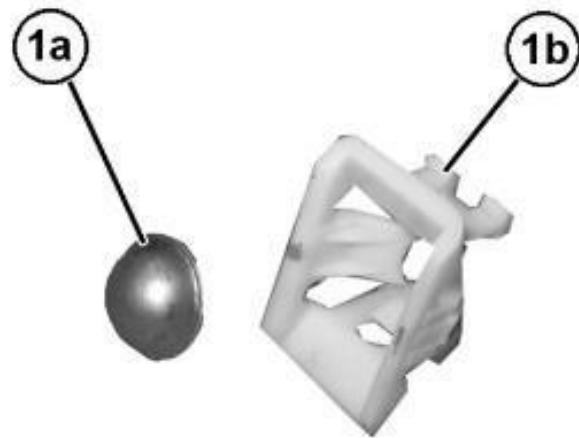
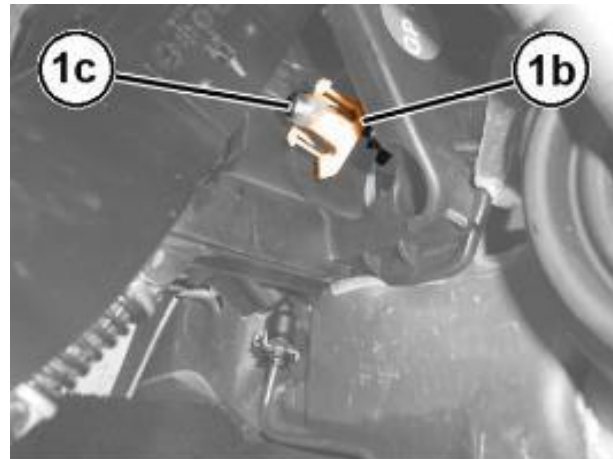

Figure 67 – Brake Pedal Retainer

63. Remove the nuts (1) attaching the ABS module to the pedal unit mounting (Figure 68).

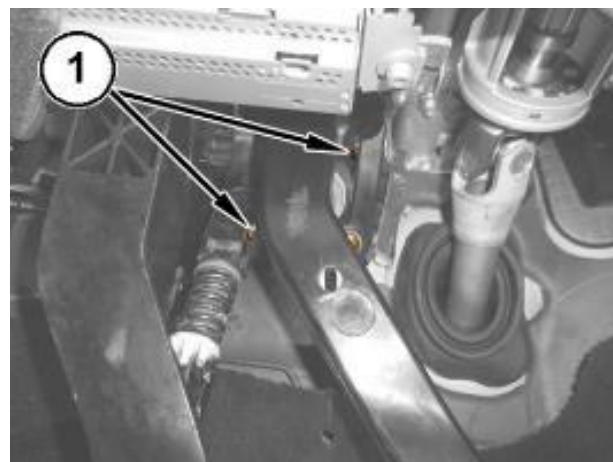

Figure 68 – ABS Module Nuts

Service Procedure [Continued]

- 64. Retract the ABS module (1a) and remove it releasing the push rod (1b) from the firewall (Figure 69).

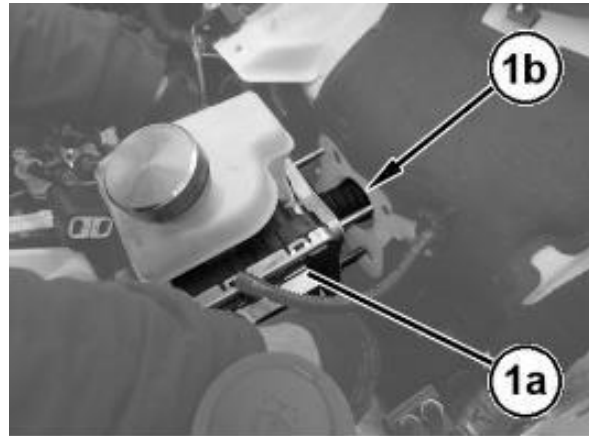

Figure 69 – ABS Module

- 65. Remove the screw (1a) and remove the ABS control module support bracket (1b) (Figure 70).

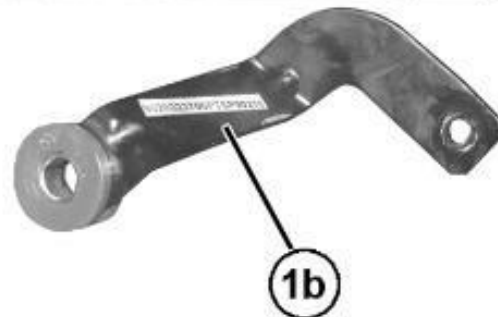
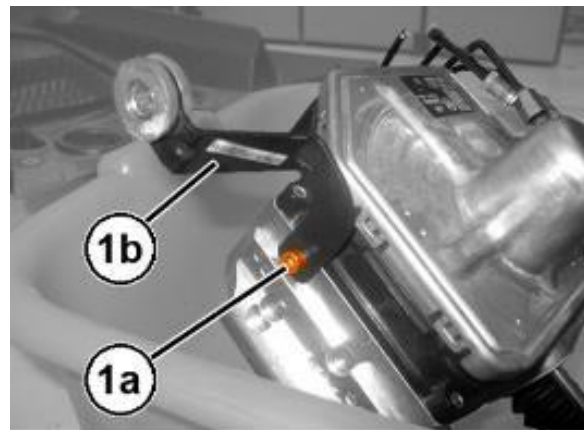

Figure 70 – ABS Module Support

Service Procedure [Continued]

66. Apply suitable silicone grease to the convex part of the cup and position it in place on the brake pedal.
67. Insert the **NEW** retaining device in the brake pedal, engaging the side clips.
68. Install the ABS control module support bracket in position and fasten with the respective attaching screw without tightening it.
69. Position the **NEW** ABS control module, with **NEW** gasket to the bulkhead then start four **NEW** mounting nuts.
70. Tighten the ABS control module **NEW** mounting nuts to the prescribed torque of 22 N·m (16 ft. lbs.).
71. Fasten and tighten the attaching screw of the ABS control module mounting bracket, on body side.
72. Tighten the screw attaching the ABS control module mounting bracket, on the ABS control module side.
73. Connect the brake fluid pipes to the ABS module, starting from the lower one and tighten the connectors manually to engage the thread correctly. Tighten the pipes to 16 N·m (12 ft. lbs.).

NOTE: The pipe ends must be aligned and perfectly perpendicular with respect to their seats to ensure that the connectors screw on correctly.

74. Apply suitable silicone grease to the push rod of the ABS module.
75. Align the ABS control unit pushrod to the brake pedal then press the brake pedal until the pushrod engages the retaining device.
76. Install the left body reinforcement in its position and tighten the attaching screws.

Service Procedure [Continued]

77. Engage the wiring retaining clip on the body pin.
78. Connect the electrical connections of the ABS module.
79. Connect the electrical connection for the brake/clutch fluid level sensor.
80. Check that the pipe from the expansion valve to the fitting is not damaged.

WARNING: Replace the connector O-rings. Only use seal washers with an elastomeric part in HNBR, resistant to refrigerant R1234YF. The use of seal washers with another elastomeric material may increase the risk of serious leaks of coolant from the climate control system.

81. Position the pipe, connect the fittings to the expansion valve, then fasten on the attaching nuts and tighten them to the prescribed torque of 8 N·m (71 In. lbs.).
82. Install the pipe bracket in position and tighten the attaching nut.
83. Connect the electrical connection for the linear pressure switch.
84. Connect the pipe fitting, then fasten the respective attaching nut and tighten it to the prescribed torque of 8 N·m (71 In. lbs.).
85. Place the outlet tube from air cleaner to left turbocharger air inlet pipe in its housing and tighten the clamps.
86. Engage the pipe between heat exchanger and left turbocharger intake to the retaining clip.
87. Connect the quick coupling of the air pipe between heat exchanger and left turbocharger intake.
88. Connect the quick coupling of the fuel vapor supply pipe to the left turbocharger intake.

Service Procedure [Continued]

89. Place the solenoid valve for consent of the fuel vapor passage to the intake in its housing, connect the fuel vapor supply pipe to the intake manifold and close the related retaining clips.
90. Connect the quick coupling of the fuel vapor supply pipe to the air sleeve between air flow meter and heat exchanger.
91. Connect the electrical connection of the solenoid valve.
92. Connect the quick coupling of the fuel vapor supply pipe to the solenoid valve and close the respective retaining clip.
93. Tighten the solenoid valve mounting bracket attaching nuts.
94. Place the degassing pipe in its housing and close the respective clamp.
95. Connect the quick coupling of the degassing pipe and close the respective retaining clip.
96. Position the windshield base trim (1a) in position and engage the retaining profile (1b) along the entire windshield base (1c) (Figure 71).

NOTE: If necessary, use soapy water to facilitate inserting the trim (1a) into the retaining profile (1b) (Figure 71).

CAUTION: Do not press the trim (1a) excessively into the retaining profile (1b) to avoid damaging the windshield (Figure 71).

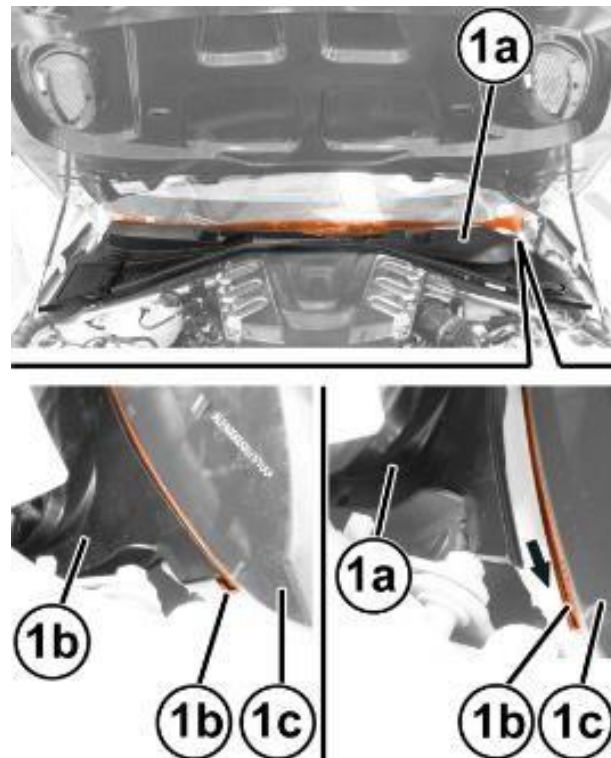

Figure 71 – Windshield Trim

Service Procedure [Continued]

97. Position the windshield base trim (1a) in position and engage the retaining profile (1b) along the entire windshield base (1c) (Figure 72).

NOTE: If necessary, use soapy water to facilitate inserting the trim (1a) into the retaining profile (1b) (Figure 72).

CAUTION: Do not press the trim (1a) excessively into the retaining profile (1b) to avoid damaging the windshield (Figure 72).

98. Apply the windshield base trim retaining buttons and engage their central pin.

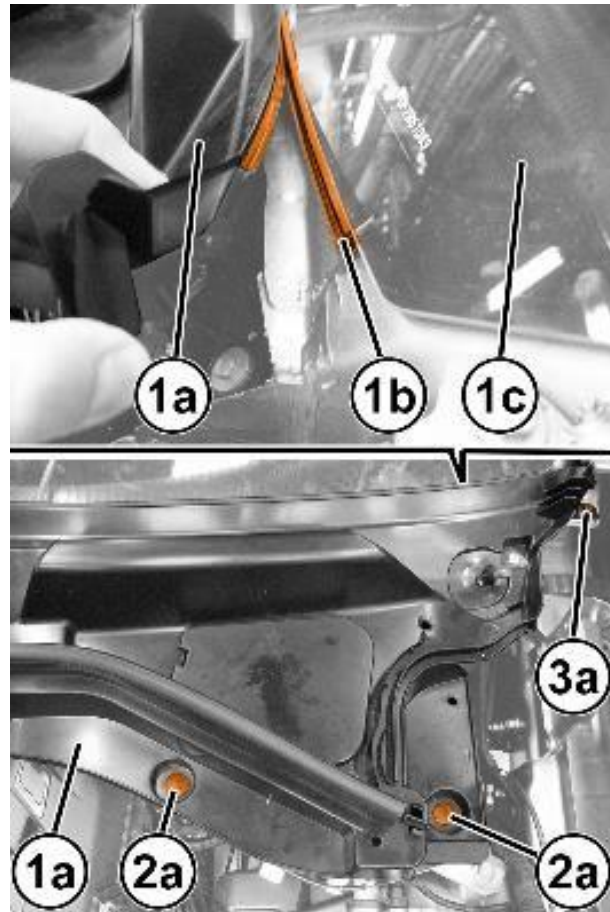
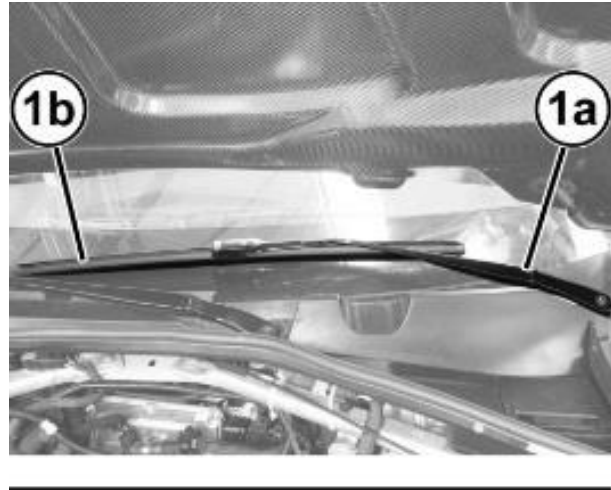

Figure 72 – Windshield Trim

99. Position the side profiles and secure them with their retaining buttons.
100. Position the side moldings and engage them, then secure them with their retaining buttons.
101. Engage the hood opening cable to the retainer.

Service Procedure [Continued]

102. Place the windshield wiper arm (1a) in position aligning the blade (1b) with the references (1c) etched on the windshield (Figure 73).



103. Insert the washer (1a) and tighten the nut (1b) to the prescribed torque of 29 N·m (21 ft. lbs.) (Figure 74).

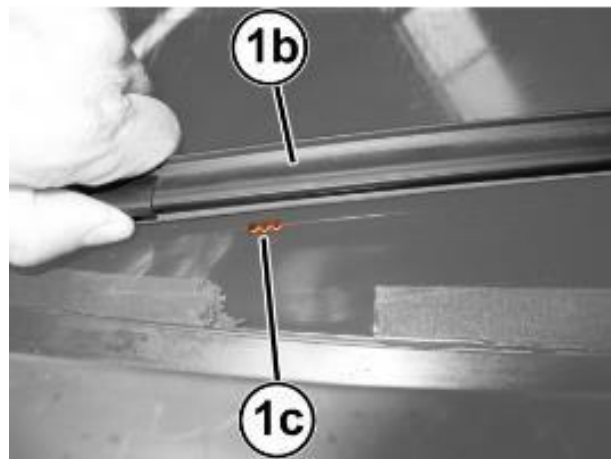

104. Restore the climate control system using an R-1234yf refrigerant recovery recycling charging station that meets SAE standard J2843.

105. Refill the cooling system with (2.95 Quarts / 11.2 Liters) of the prescribed fluid (MS.90032).

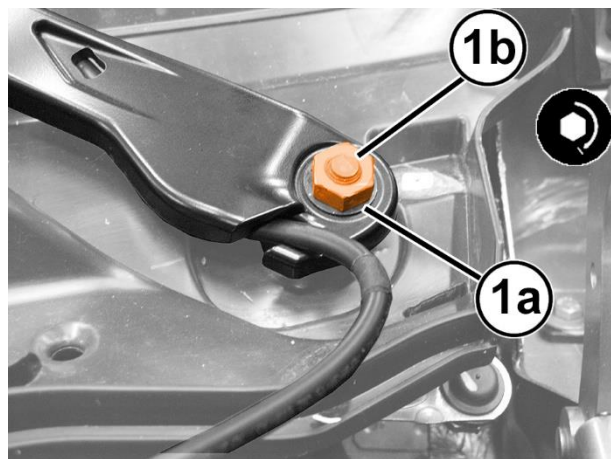

106. Start the procedure for re-pressurizing the refrigerant fluid, following the instructions in the equipment manual.

Figure 73 – Wiper Arm

Figure 74 – Wiper Arm

Service Procedure [Continued]

107. Fill with the prescribed quantity of refrigerant: R1234yf 1.18 lb / .535 kg.
108. Open the hood and put the soundproofing cover back in its housing engaging the retaining pins.
109. Check that the air vent is correctly positioned in its housing, then engage the retaining button with central pin.
110. Take the lower trim and connect the electrical connections to the courtesy lights.
111. Position the lower trim, engaging the retainers and fastening the attaching screws.
112. Position the console side closure and engage its inner retainers.
113. Bleed air from the hydraulic brake system as described below:
114. Remove the wheel studs then remove the front and rear wheels.

CAUTION: Replace the fluid in the pressure bleeder with NEW fluid meeting the specification DOT4 MS.90039.

115. Connect the bleeding equipment (1) to the brake fluid reservoir and pressurize the system (Figure 75).

NOTE: The operating pressure must be kept at 2 - 3 bar (29 - 43 psi) during the “First stage” and “Second stage” described below.

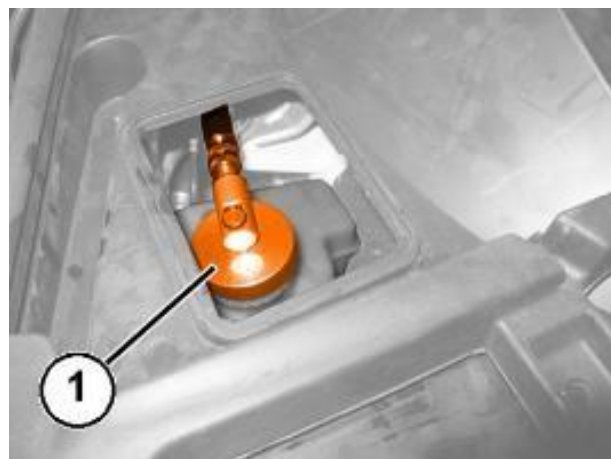

Figure 75 – Bleeding Equipment

Service Procedure [Continued]

116. Working at the right front caliper, position the brake fluid recovery hose to the INNER bleeder screw (1) and to the recovery container. Open the INNER bleeder screw (1) and without applying any pedal pressure on the system, allow a small amount of brake fluid to drain into the recovery container. Then tighten the bleeder screw and remove the recovery hose (Figure 76).

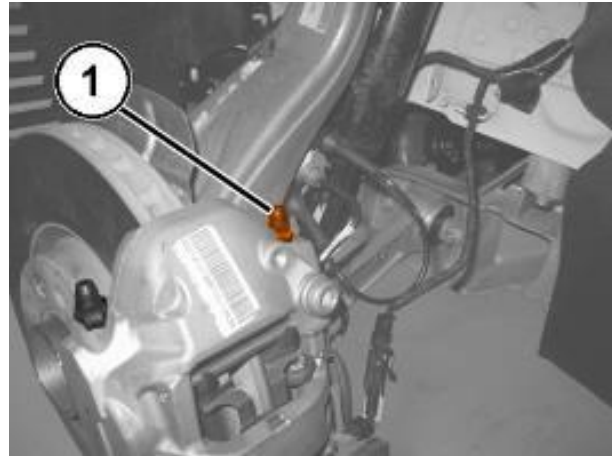

Figure 76 – Brake Bleeder Valve

117. Repeat the above operation on the front left brake caliper.

118. Working at the right rear caliper, position the brake fluid recovery hose to the bleeder screw (1) and to the recovery container. Open the bleeder screw (1) and without applying any pedal pressure on the system, allow a small amount of brake fluid to drain into the recovery container. Then tighten the bleeder screw and remove the recovery hose (Figure 77).

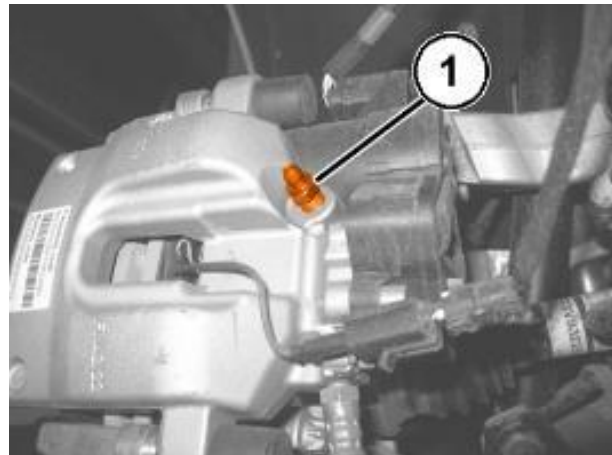

Figure 77 – Brake Bleeder Valve

119. Repeat the above operation on the rear left brake caliper.

120. Working at the left front caliper, position the brake fluid recovery hose to the INNER bleeder screw (1) and to the recovery container. Open the bleeder screw and slowly press the brake pedal down fully three or more times, until there are no more air bubbles in the recovery hose. Then tighten the bleed valve to the prescribed torque of 10 N·m (89 In. lbs.) (Figure 76).

Service Procedure [Continued]

121. Repeat the bleed procedure on the OUTER bleeder screw of the left front caliper.
122. Repeat the above operation on the left front brake caliper.
123. Connect the pipe to the valve of the rear right brake caliper. Open the valve, slowly press the brake pedal down fully three or more times, until there are no more air bubbles in the hose through which the oil flows into the container. Tighten the bleed valve to the prescribed torque of 10 N·m (89 In. lbs.) (Figure 77).
124. Repeat the above operation on the rear left brake caliper.
125. Connect the car's electrical system.
126. Connect the terminal to the dummy negative pole of the battery and check that the retainer is correctly coupled. Connect the IBS connector if equipped.
127. Connect the wiTECH diagnosis equipment to the vehicle data link connector of the vehicle, go to the ABS control module in the “**Miscellaneous Functions**” menu and start the “**Replace Control Module**” and “**Check Air Presence in Hydraulic System Between Control Module and Brake Caliper**” procedure.
128. Check that the value of FL - FR - RR - RL volumes shown on the diagnosis equipment are within the ranges shown in the table:

VERSION	STEEL DISCS		CARBON-CERAMIC DISCS	
	MIN	MAX	MIN	MAX
FL (mm ³)	1450	2560	1900	3110
FR volume (mm ³)	1580	2690	2190	3400
RR volume (mm ³)	830	1920	750	1840
RL volume (mm ³)	815	1905	735	1825

129. If even only one of the values shown in the aforementioned table is higher than the reference threshold, repeat the bleeding procedure as instructed by the diagnosis equipment.

Service Procedure [Continued]

130. If after repeating the bleeding procedure, the maximum values for the rear calipers are still higher than the limit values, proceed as described below on the rear calipers only.
131. Find the out of tolerance caliper and remove it without disconnecting the hose.
132. Turn the brake caliper very slowly several times to the various possible positions, stop the motion and keep the bleed valve pointing upwards for a few minutes.
133. Install the brake caliper(s), then repeat the bleeding steps for the caliper(s) and check the volumes using the diagnosis equipment.
134. Position the right side flap of the battery housing and engage the retainers.
135. Close the hood.
136. Check the operation of the windshield wiper.
137. Check the operation of the electrical system.
138. Check that the time/day etc. are correct.
139. Reposition the luggage compartment lid opening cord in its housing and close the cap.
140. Close the luggage compartment lid.

**Figure 78 – Rotate Caliper**

Service Procedure [Continued]

141. The steering must be initialized after the battery has been disconnected. This will be indicated by a warning light on the instrument panel turning on. To carry out this procedure, just start the engine, turn the steering wheel from one lock to the other and put it back into the center position.
142. Enable automatic electric handbrake engagement when the engine stops. Connect the wiTECH diagnosis equipment to the vehicle data link connector of the vehicle, select ABS “**Miscellaneous Functions**”, select “**Electric Park Brake (EPB)**” then start the “**Assembly Check**” procedure.
143. From the Connect system, switch automatic handbrake enable from **ON > OFF** and immediately after from **OFF > ON**.
144. Remove the car from the lift.

Service Procedure [Continued]

C. (GU) Alfa Romeo Stelvio with EC2-2.0L engine.

1. Position the vehicle on a suitable hoist.
2. Perform the electric handbrake disengagement procedure. Connect the wiTECH diagnosis equipment to the vehicle data link connector of the vehicle, select Antilock Brake System (ABS) in the “**Miscellaneous Functions**” select “**Electric Park Brake (EPB)**”, then start the “**Maintenance Mode**”.

NOTE: If the ABS control module is replaced, connect the wiTECH diagnosis equipment to the vehicle data link connector, go to "ABS control module" and start the "Control module replacement" procedure.

3. Raise the door windows to the upper end of travel position.

NOTE: Disconnecting the battery when the windows are in a position other than the upper end of travel will entail the need to run the window end of travel learning procedure.

4. Open the luggage compartment lid and support it so it will not close.

NOTE: If the luggage compartment lid closes while the battery is disconnected, it will not be possible to reopen it. The rear seat may need to be folded down to gain access to the luggage compartment area.

Service Procedure [Continued]

5. To be able to reopen the luggage compartment lid, even if it accidentally closes with the battery disconnected, before disconnecting the battery it is necessary to Remove cover (1b) on the luggage compartment lid (1a). There is a cable (2a) that is attached to the cover that will pull out of the opening. Leave it hanging out of the luggage compartment. Then pull the cable to release the luggage compartment lid latch (Figure 79).

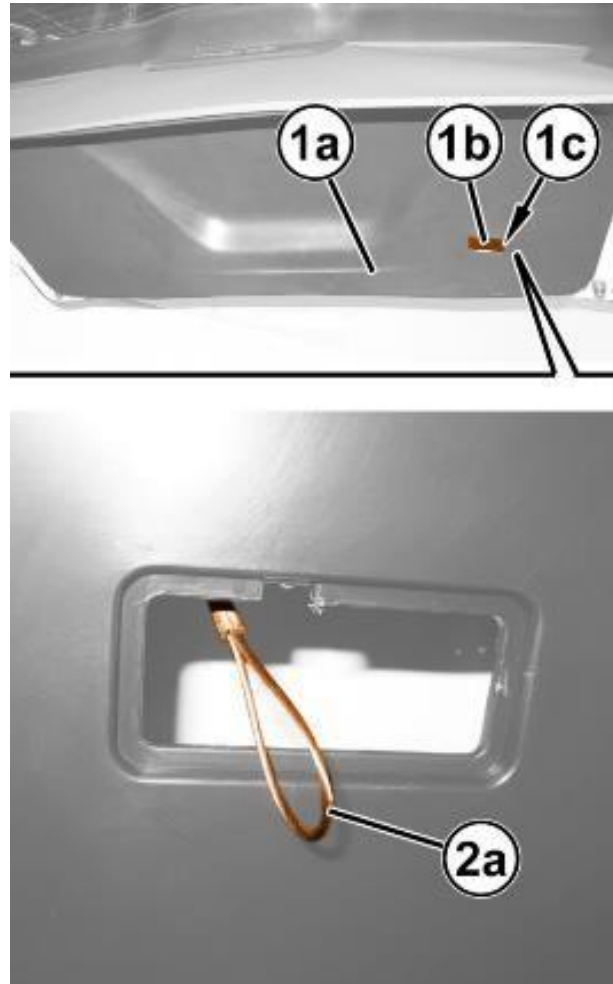
**Figure 79 – Lid Lock Release**

Service Procedure [Continued]

6. Using the handle (1b), lift out the load floor cover (1a) (Figure 80).



Figure 80 – Load Floor Cover

7. Remove the battery cover (1a). (Figure 81).

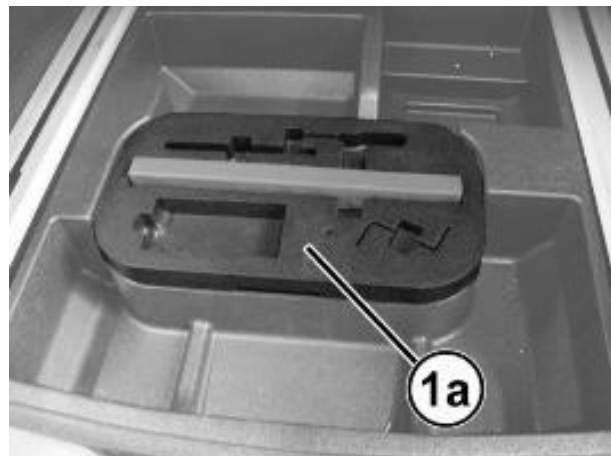

Figure 81 – Battery Cover

8. If equipped with an Intelligent Battery Sensor (IBS), disconnect the IBS connector.
9. Press the retainer (1a) and disconnect the terminal (1b) from the “negative dummy terminal” (1c) of the battery (1d) (Figure 82).
10. Move the terminal out of the way and isolate it (1b) (Figure 82).

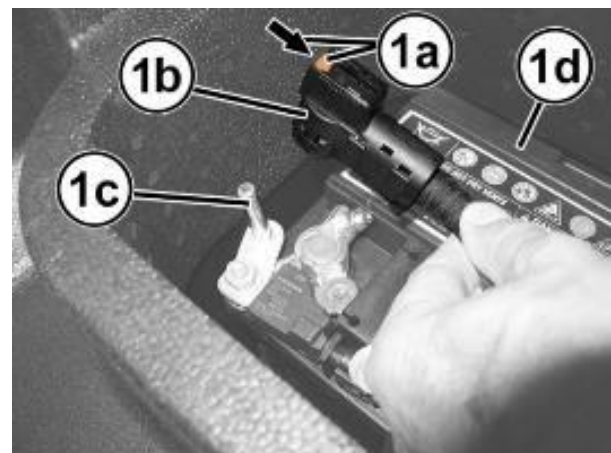

Figure 82 – Battery Negative Cable

Service Procedure [Continued]

11. Remove the console side closure (1a), by disengaging the various inner retainers (1b) using the appropriate tool 2000040516 (Figure 83).

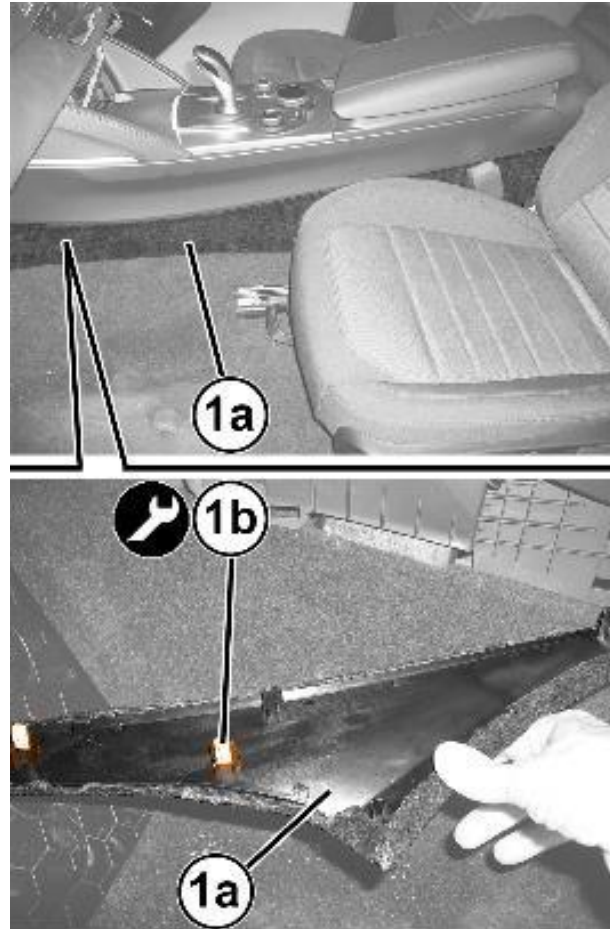
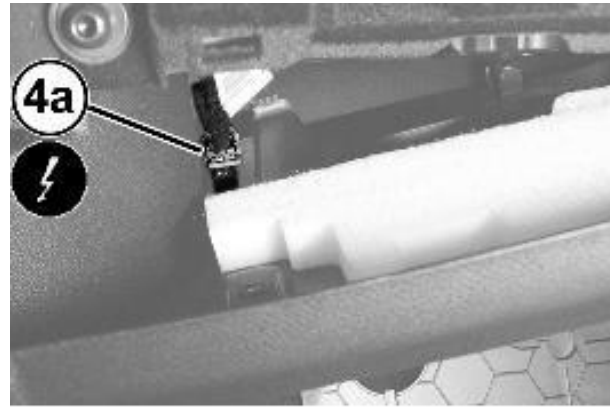

Figure 83 – Console Side Closure

Service Procedure [Continued]

12. Remove the screws from the housings (1a) of the lower lining (1b) (Figure 84).



13. Release the retaining button from the housing (2a), using the special tool Trim Stick C-4829A (1823015000) (Figure 84).

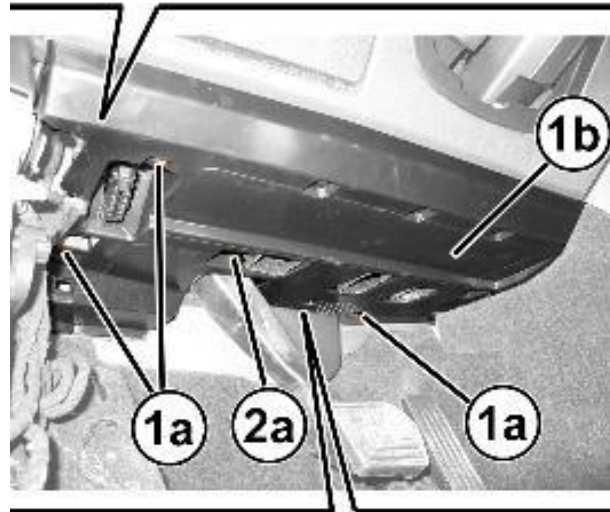

14. Pull down the lower lining (1b) by releasing the inner retainers (3a) (Figure 84).



15. Disconnect the electrical connection (4a) for the courtesy lights on the lower lining (Figure 84).

Figure 84 – Lower Lining

Service Procedure [Continued]

16. Use tool Trim Stick C-4829A (1823015000) to disconnect the retaining pin with central pin (1a) and release the air vent (2a) (Figure 85).

CAUTION: Carefully move the air vent (2a) only when accessing the ABS module fasteners to avoid damaging it.

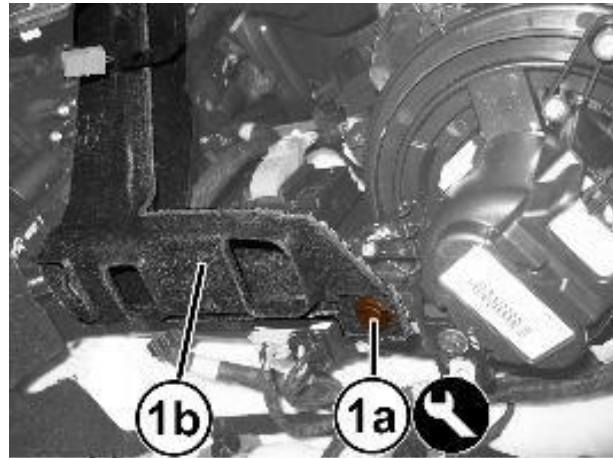

Figure 85 – Air Vent

17. Remove the screws (1a) and remove the strut bar (1b) (Figure 86).

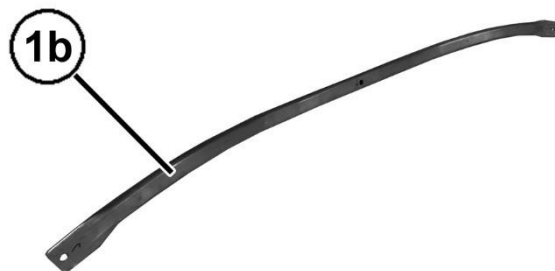
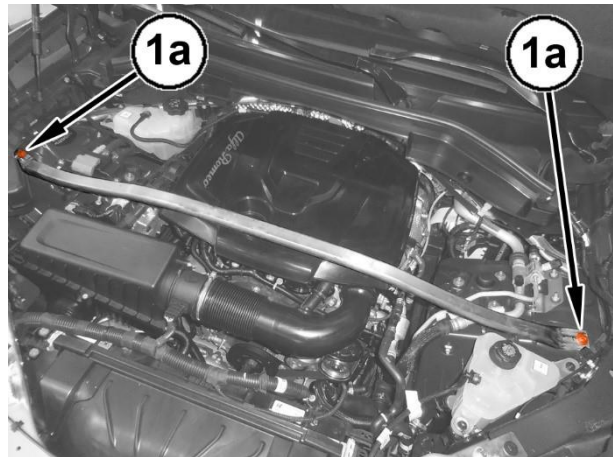
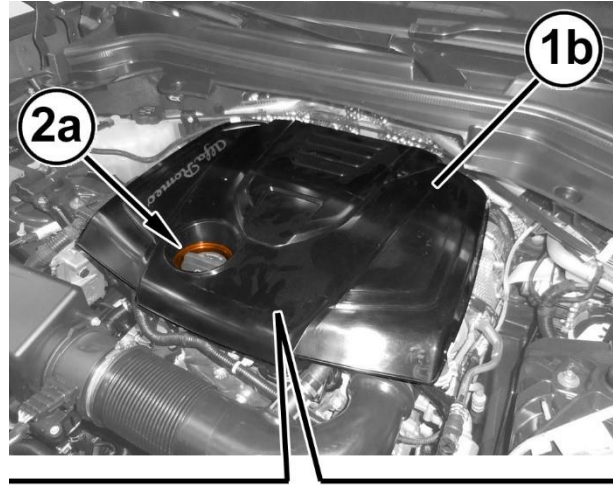

Figure 86 – Strut Bar

Service Procedure [Continued]

- 18. Disengage covers (1a) of the cover (1b) and remove the screws (1c) (Figure 87).



- 19. Disengage from the rear retaining pins and remove the soundproofing cover (1b) complete with seal (2a) for the engine oil (Figure 87).

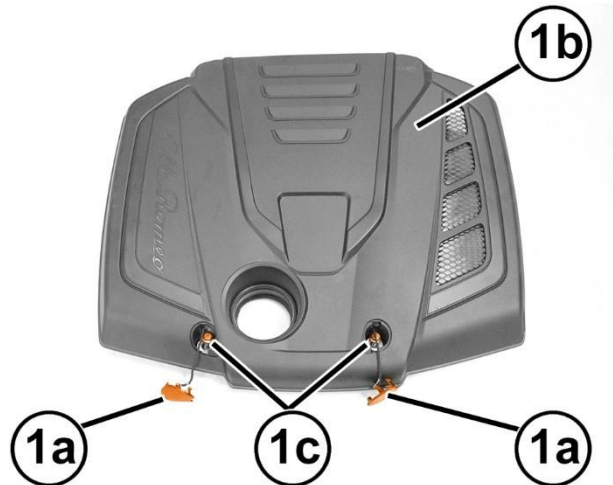

Figure 87 – Soundproofing Cover

Service Procedure [Continued]

20. Release from its housing the pipe (1a) of the windshield wiper arm (1b) or (1c) that is being detached (Figure 88).
21. Disconnect the electrical connection (2a) for the concerned windshield wiper arm (1b) or (1c) (Figure 88).
22. Disconnect the quick connector (3a) of the pipe (1a) that is being detached (Figure 88).
23. Release the nut cover (4a) at the base of the windshield wiper arm that is being detached (Figure 88).

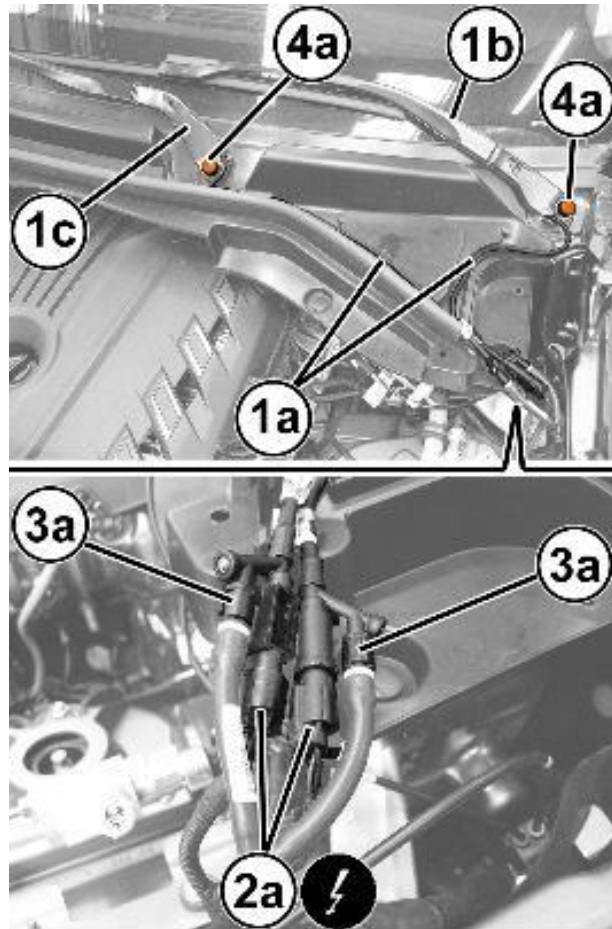
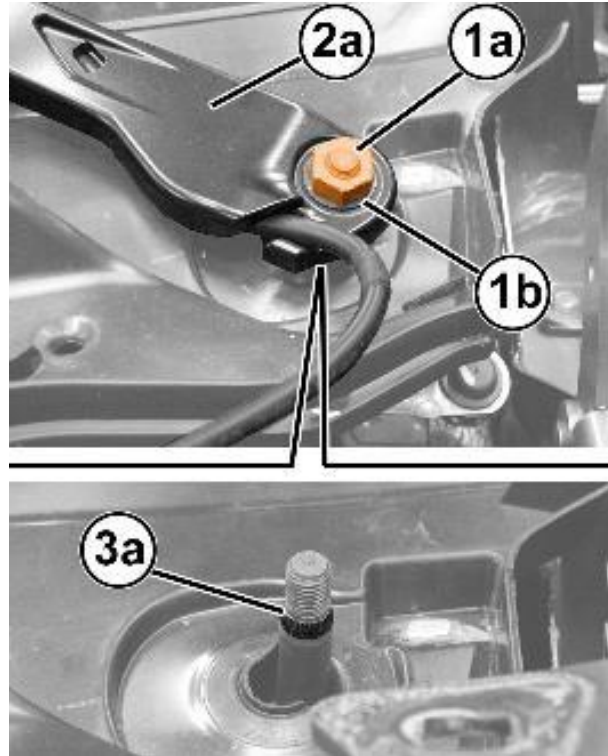

Figure 88 – Wiper Arm

Service Procedure [Continued]

24. Remove the nut (1a) and keep the washer (1b) (Figure 89).
25. Remove the windshield wiper arm (2a) complete with the pipe and windshield washer jet (Figure 89).
26. If necessary, remove the wiper arm using a suitable extractor to release the ribbed truncated cone coupling (3a) (Figure 89).

**Figure 89 – Wiper Arm**

Service Procedure [Continued]

27. Working on the right side of the windshield frame trim (1a), remove the screws (1b) (Figure 90).

28. Working on the left side of the windshield frame trim (1a), remove the screw (1b) (Figure 91).

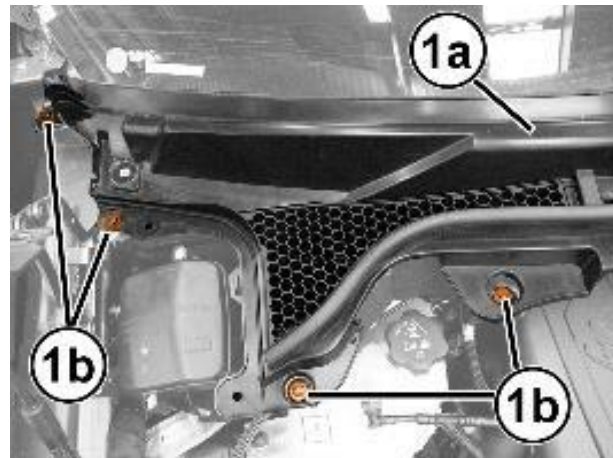

Figure 90 – Windshield Trim

29. Remove the retaining buttons (2a) with central pin, using the appropriate tool Trim Stick C-4829A (1823015000) (Figure 91).

30. Starting from one end (3a), gradually release the windshield frame trim (1a) from the retaining profile (3b) along the windshield base (3c) (Figure 91).

CAUTION: Work carefully to avoid damaging the windshield (3c) and the profile (3b) (Figure 91).

31. Keep the windshield base trim (1a) (Figure 91).

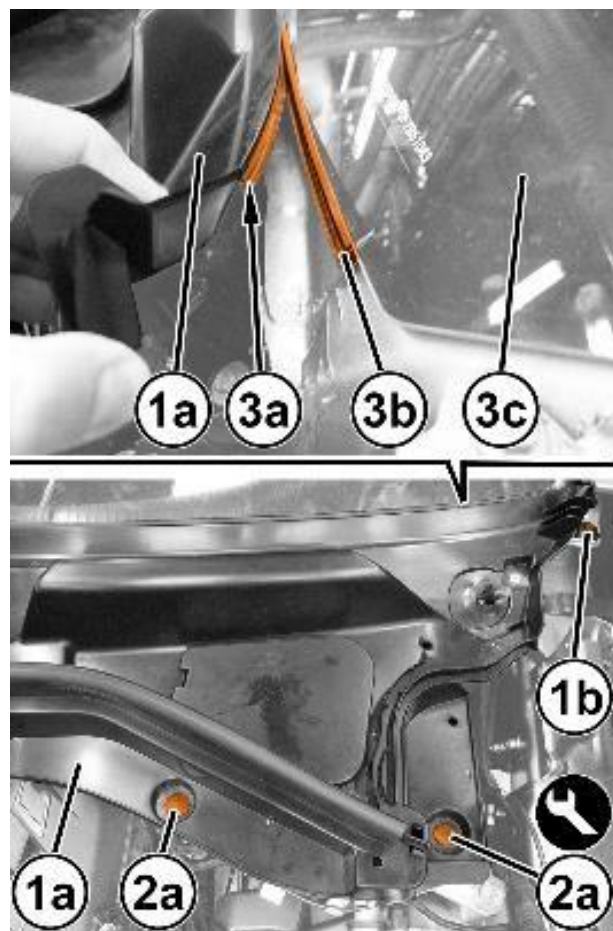
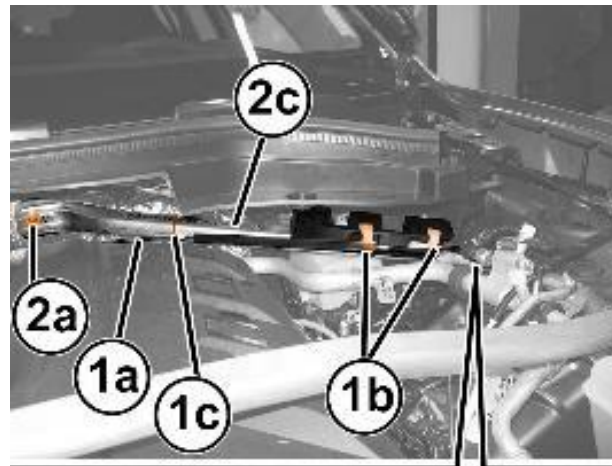

Figure 91 – Windshield Trim

Service Procedure [Continued]

32. Release the rod (1a) from the retainers (1b) and the band (1c) (Figure 92).



33. Remove the nut (2a) and the screws (2b), and remove the left bar (2c), releasing it from its position (Figure 92).

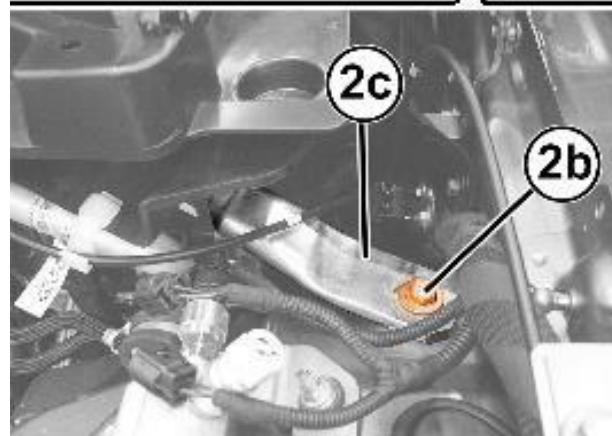

Figure 92 – Body Reinforcement

34. Remove the screws (1a) that secure the windshield wiper assembly (1b) (Figure 93).

35. Move the windshield wiper assembly (1b) slightly and disconnect the electrical connection (2a) from the windshield wiper motor (Figure 93).

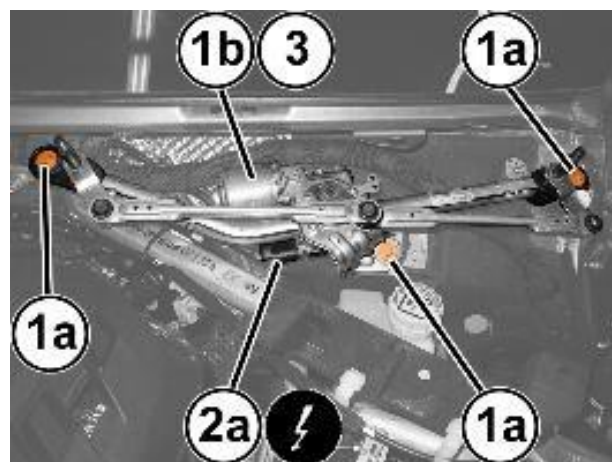

Figure 93 – Wiper Assembly

36. Keep the windshield wiper assembly (3) (Figure 93).

Service Procedure [Continued]

37. Remove the brake/clutch fluid reservoir plug and install the tool 2000001400.

CAUTION: It is not necessary to drain the brake system to detach the ABS module. Failure to observe this requirement may mean replacing the brake calipers.

38. Release the wiring (1a) and disconnect the electrical connection (1) for the upper oxygen sensor (Figure 94).

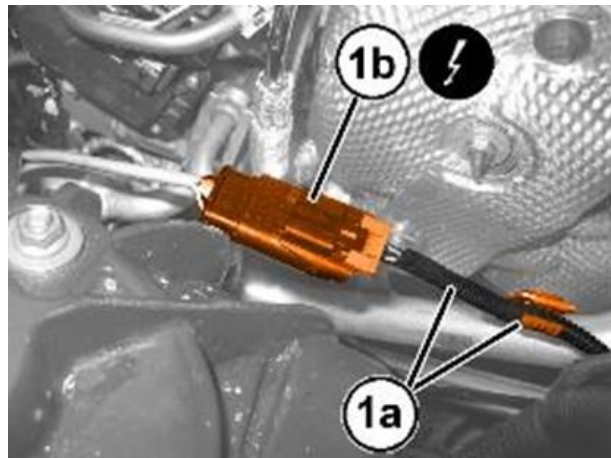

Figure 94 – Electrical Connector

39. Disconnect the electrical connection (1) of the brake fluid minimum level warning light switch (Figure 95).

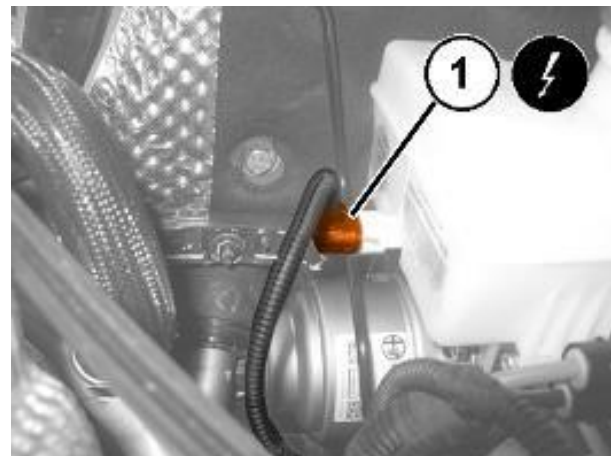

Figure 95 – Electrical Connector

Service Procedure [Continued]

40. Disconnect the electrical connection (1) of the ABS control module (Figure 96).

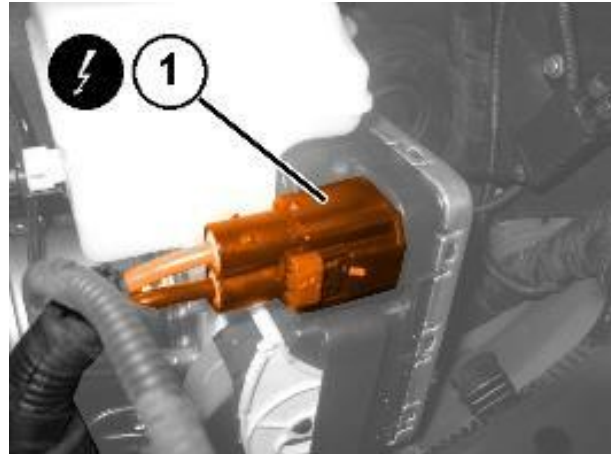

Figure 96 – Electrical Connector

41. Disconnect the electrical connection (1) of the ABS control module (Figure 97).

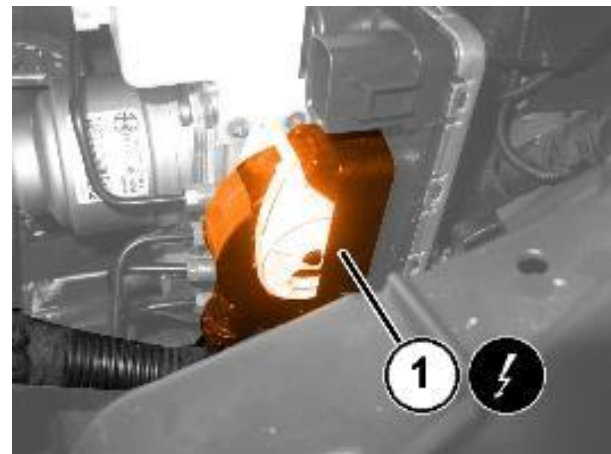

Figure 97 – Electrical Connector

42. Unscrew the connectors (1a) and disconnect the brake fluid pipes (1b) from the ABS control module (Figure 98).

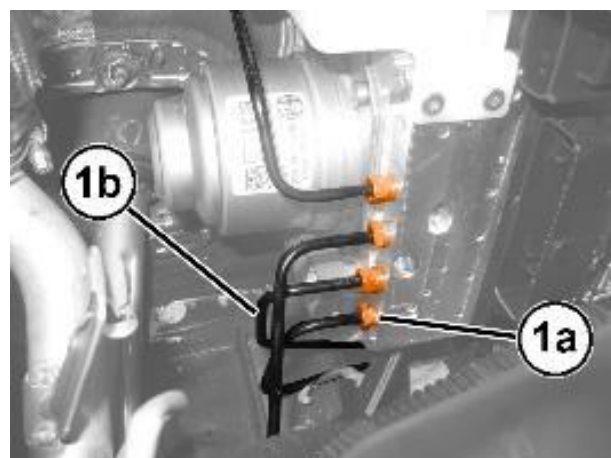

Figure 98 – Brake Fluid Pipes

Service Procedure [Continued]

43. Remove the nut (1a) and disconnect the earth lead (1b) from the body (Figure 99).

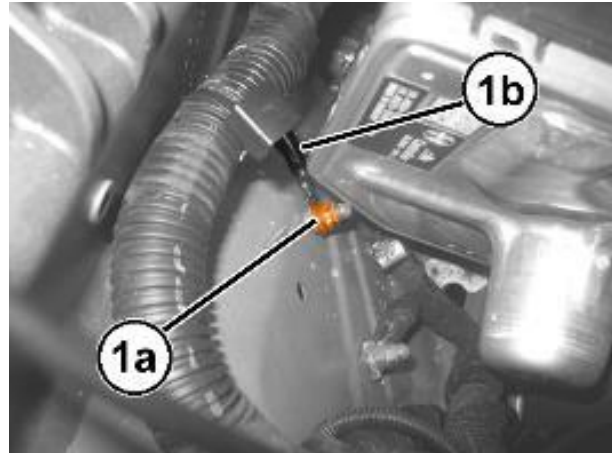

Figure 99 – Electrical Ground

44. Remove the attaching screw (1) of the ABS control module mounting bracket to the body (Figure 100).

NOTE: To facilitate the subsequent removal of the ABS control module, we advise loosening the screws attaching the aforementioned bracket to the ABS module first.

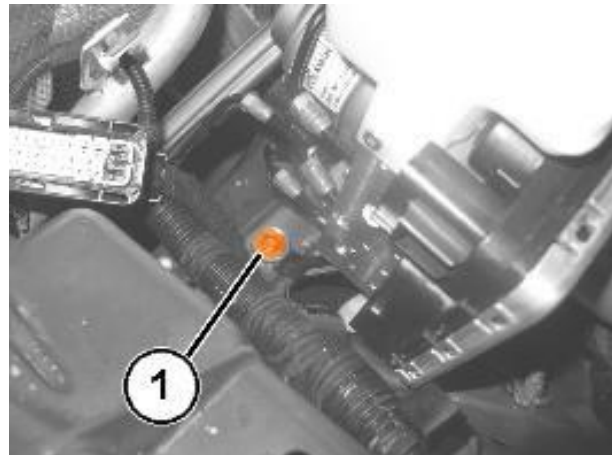

Figure 100 – Mounting Bracket

Service Procedure [Continued]

45. Using the brake switch pliers 2000010500 (1a) positioned on the rear part of the holes (1b) of the brake pedal, compress the retaining device (1c) and retract the brake pedal (1d) at the same time in order to release the pedal from the ABS module push rod (Figure 101).

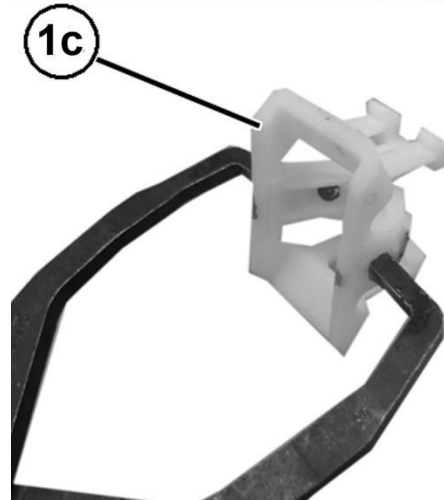
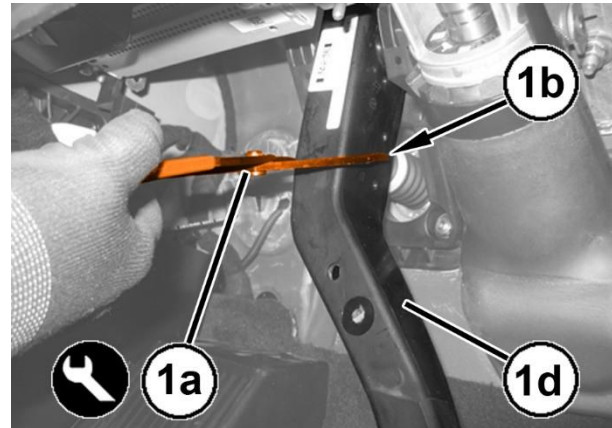

Figure 101 – Brake Pedal Retainer

Service Procedure [Continued]

46. Remove the cup (1a) and the retaining device (1b) from the push rod of the ABS control module (1c) (Figure 102).

NOTE: The retaining device must be replaced whenever the push rod is disconnected.

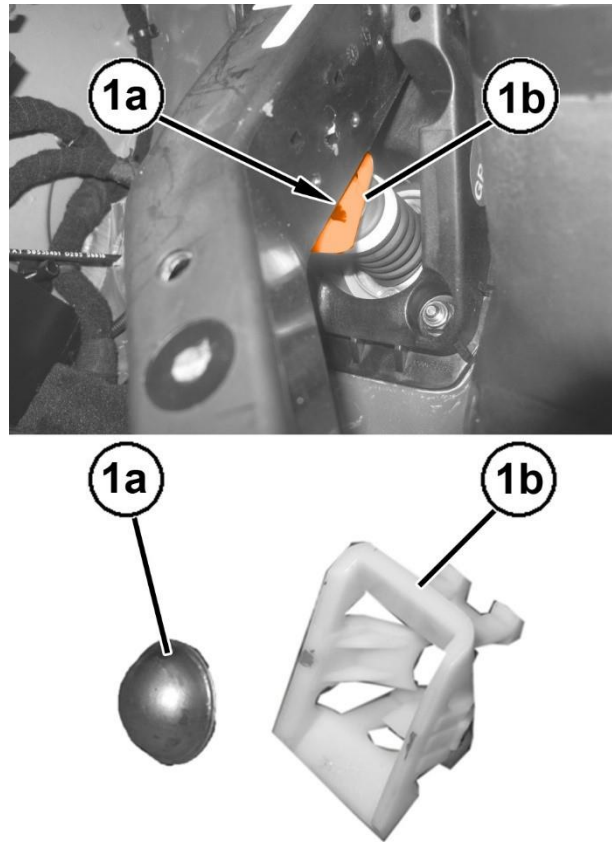

Figure 102 – Brake Pedal Retainer

47. Remove the nuts (1) attaching the ABS module to the pedal unit mounting (Figure 103).

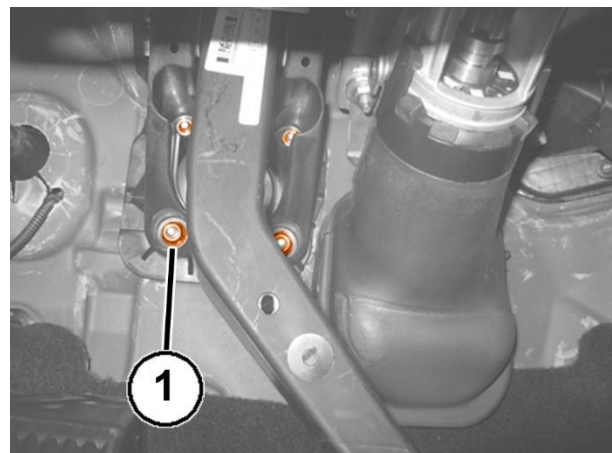

Figure 103 – ABS Module Nuts

Service Procedure [Continued]

- 48. Retract the ABS module (1a) and remove it releasing the push rod (1b) from the firewall (Figure 104).

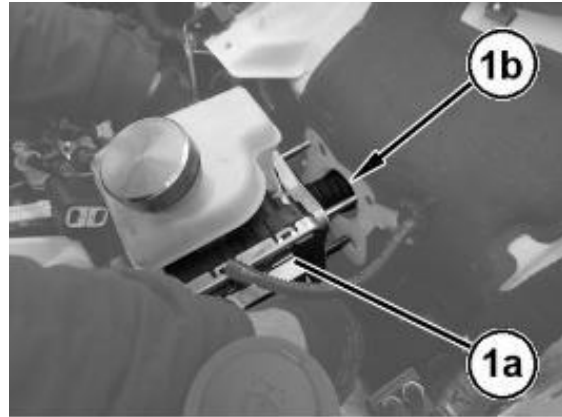

Figure 104 – ABS Module

- 49. Remove the screw (1a) and remove the ABS control module support bracket (1b) (Figure 105).

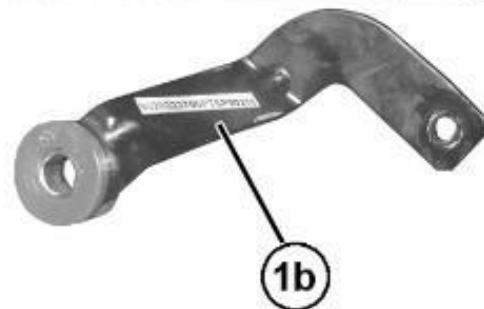
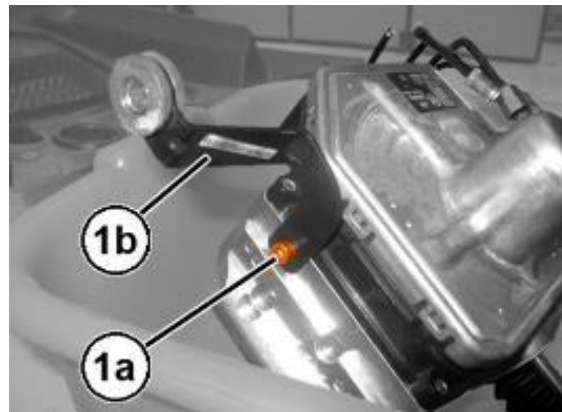

Figure 105 – ABS Module

Service Procedure [Continued]

50. Apply suitable silicone grease to the convex part of the cup and position it in place on the brake pedal.
51. Insert the **NEW** retaining device in the brake pedal, engaging the side clips.
52. Install the ABS control module support bracket in position and fasten the respective attaching screw without tightening it.
53. Position the **NEW** ABS control module, with **NEW** gasket to the bulkhead then start four **NEW** mounting nuts.
54. Tighten the ABS control module **NEW** mounting nuts to the prescribed torque of 22 N·m (16 ft. lbs.).
55. Fasten and tighten the attaching screw of the ABS control module mounting bracket, on body side.
56. Tighten the screw attaching the ABS control module mounting bracket, on the ABS control module side.
57. Connect the brake fluid pipes to the ABS module, starting from the lower one and tighten the connectors manually to engage the thread correctly. Tighten the pipes to 16 N·m (12 ft. lbs.).

NOTE: The pipe ends must be aligned and perfectly perpendicular with respect to their seats to ensure that the connectors screw on correctly.

58. Apply suitable silicone grease to the push rod of the ABS module.
59. Align the ABS control unit pushrod to the brake pedal then press the brake pedal until the pushrod engages the retaining device.

Service Procedure [Continued]

- 60. Engage the wiring retaining clip on the body pin.
- 61. Connect the electrical connections of the ABS module.
- 62. Connect the electrical connection for the brake/clutch fluid level sensor.
- 63. Connect the electrical connection of the windshield wiper motor and place the windshield wiper unit in its housing.

64. Tighten the attaching screws of the windshield wiper unit and tighten them to the prescribed torque of 8 N·m (71 In. lbs.).

65. Position the left bar (1a), and tighten the screws (1b) and the nut (1c) to the prescribed torque of 20 N·m (15 ft. lbs.) (Figure 106).

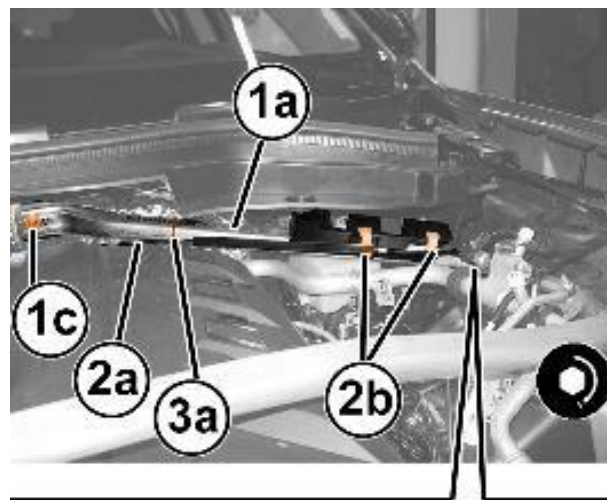

66. Secure the rod (2a) to the retainers (2b) and the band (1c) (Figure 106).

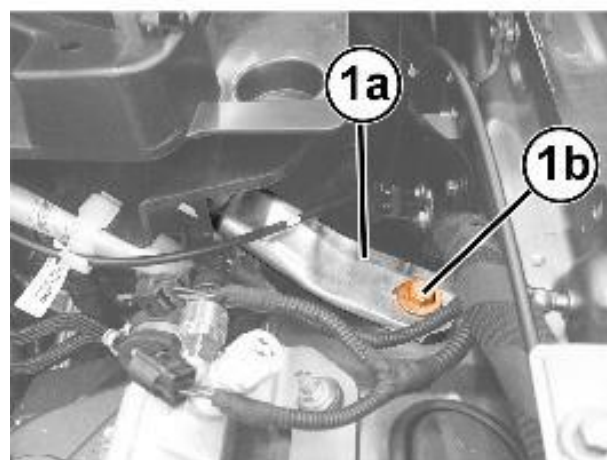

67. Apply the band (3a) (Figure 106).

Figure 106 – Body Reinforcement

Service Procedure [Continued]

68. Position the windshield base trim (1a) in position and engage the retaining profile (1b) along the entire windshield base (1c) (Figure 107).

NOTE: If necessary, use soapy water to facilitate inserting the trim (1a) into the retaining profile (1b) (Figure 107).

CAUTION: Do not press the trim (1a) excessively into the retaining profile (1b) to avoid damaging the windshield (Figure 107).

69. Apply the retaining buttons (2a) with central pin (Figure 107).

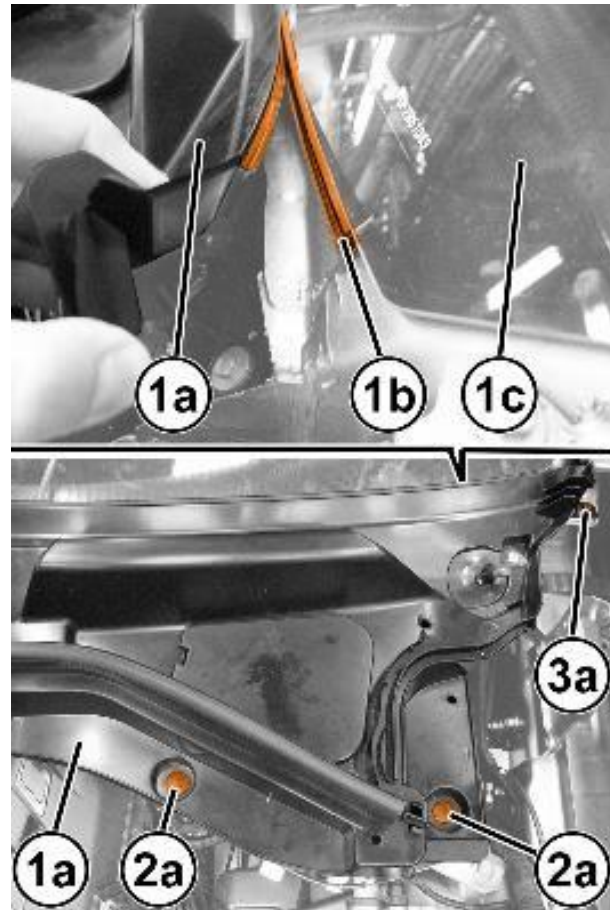

Figure 107 – Windshield Trim

70. Tighten the screw (3a) (Figure 107).
71. Working on the right side of the windshield frame trim, tighten the attaching screws.

Service Procedure [Continued]

72. Place the windshield wiper arm (1a) in position aligning the blade (1b) with the references (1c) etched on the windshield (Figure 108).

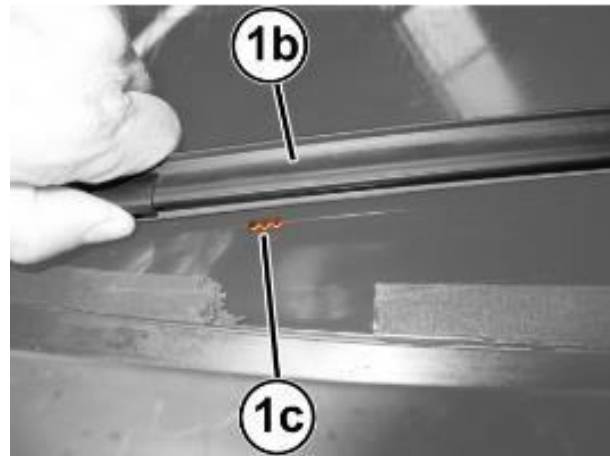
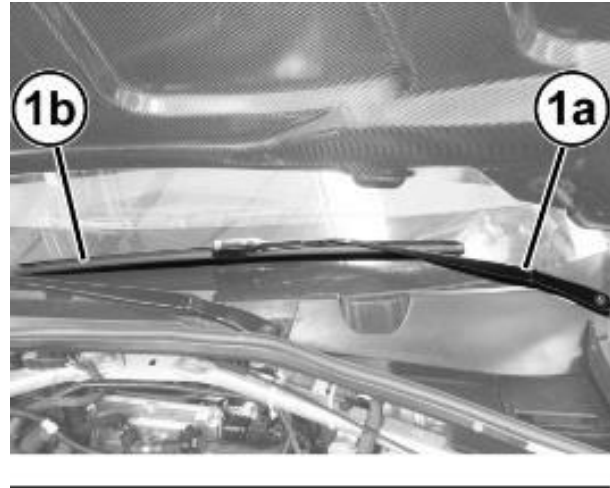

Figure 108 – Wiper Arm

73. Insert the washer (1a) and tighten the nut (1b) to the prescribed torque of 29 N·m (21 ft. lbs.) (Figure 109).

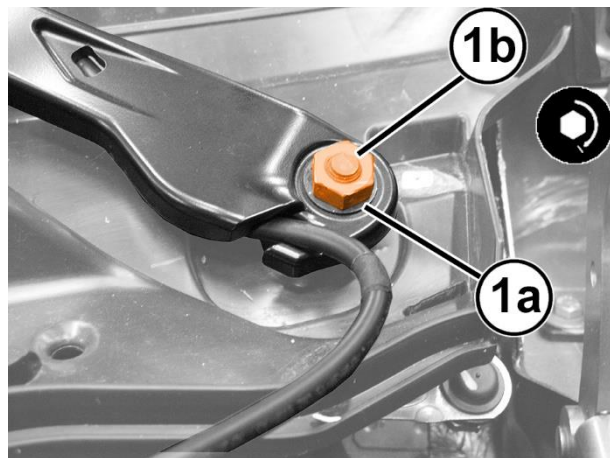
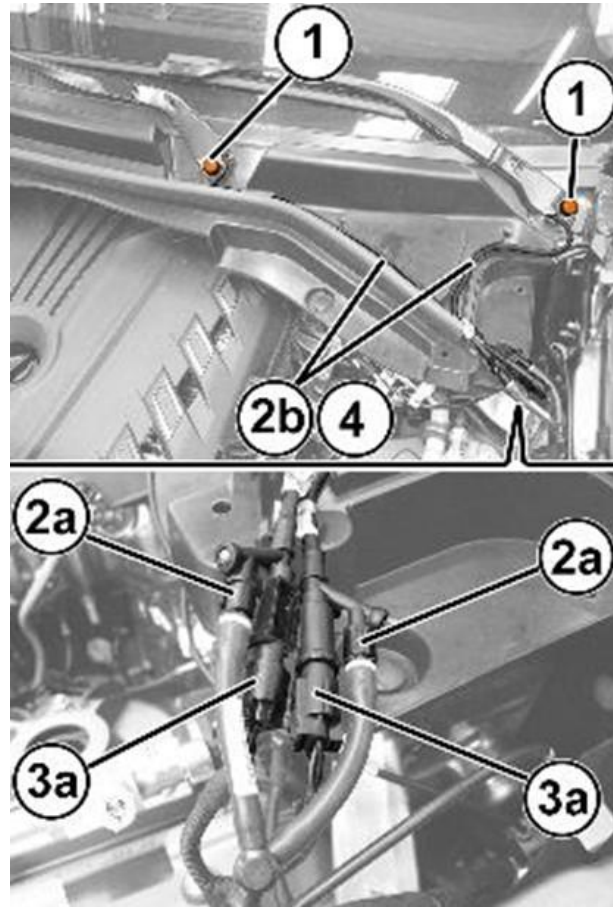

Figure 109 – Wiper Arm

Service Procedure [Continued]

74. Engage the nut cover (1) (Figure 110).
75. Connect the quick connector (2a) of the pipe (2b) concerned (Figure 110).
76. Connect the concerned electrical connection (3a) (Figure 110).
77. Place the pipe (2b) concerned in position (Figure 110).
78. Put the soundproofing cover back in its housing engaging the retaining pins.
79. Check that the air vent is correctly positioned in its housing, then engage the retaining button with central pin.

**Figure 110 – Wiper Arm**

80. Take the lower trim and connect the electrical connections to the courtesy lights.
81. Position the lower trim, engaging the retainers and fastening the attaching screws.
82. Position the console side closure and engage its inner retainers.
83. Bleed air from the hydraulic brake system as described below:
84. Remove the wheel studs then remove the front and rear wheels.

CAUTION: Replace the fluid in the pressure bleeder with NEW fluid meeting the specification DOT4 MS.90039.

Service Procedure [Continued]

85. Connect the bleeding equipment (1) to the brake fluid reservoir and pressurize the system (Figure 111).

NOTE: The operating pressure must be kept at 2 - 3 bar (29 - 43 psi) during the “First stage” and “Second stage” described below.

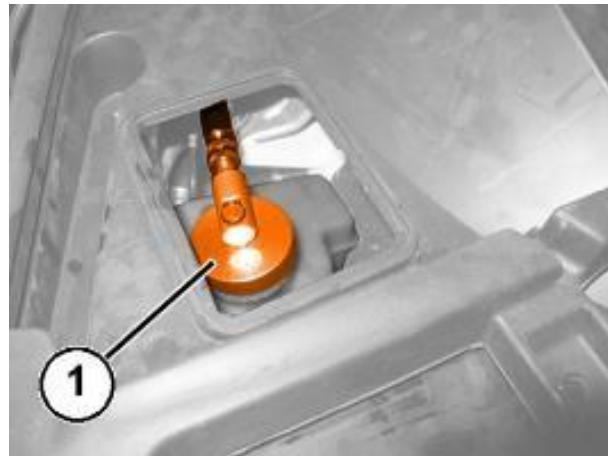

Figure 111 – Bleeding Equipment

86. Working at the right front caliper, position the brake fluid recovery hose to the INNER bleeder screw (1) and to the recovery container. Open the INNER bleeder screw (1) and without applying any pedal pressure on the system, allow a small amount of brake fluid to drain into the recovery container. Then tighten the bleeder screw and remove the recovery hose (Figure 112).

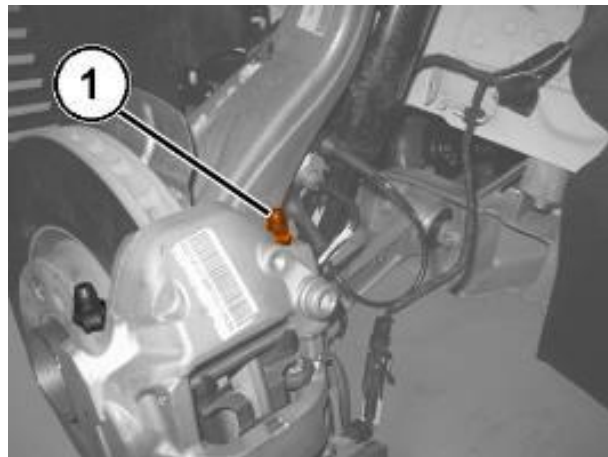

Figure 112 – Brake Bleeder Valve

87. Repeat the above operation on the left front brake caliper.
88. Working at the right rear caliper, position the brake fluid recovery hose to the bleeder screw (1) and to the recovery container. Open the bleeder screw (1) and without applying any pedal pressure on the system, allow a small amount of brake fluid to drain into the recovery container. Then tighten the bleeder screw and remove the recovery hose (Figure 113).
89. Repeat the above operation on the left rear brake caliper.

Service Procedure [Continued]

90. Working at the left front caliper, position the brake fluid recovery hose to the INNER bleeder screw (1) and to the recovery container. Open the bleeder screw and slowly press the brake pedal down fully three or more times, until there are no more air bubbles in the recovery hose. Then tighten the bleed valve to the prescribed torque of 10 N·m (89 In. lbs.) (Figure 112).

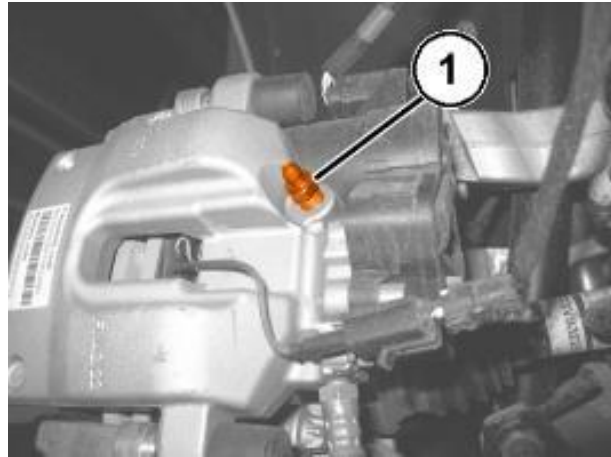

Figure 113 – Brake Bleeder Valve

91. Repeat the bleed procedure on the OUTER bleeder screw of the left front caliper.
92. Repeat the above operation on the left front brake caliper.
93. Connect the pipe to the valve of the rear right brake caliper. Open the valve, slowly press the brake pedal down fully three or more times, until there are no more air bubbles in the hose through which the oil flows into the container. Tighten the bleed valve to the prescribed torque of 10 N·m (89 In. lbs.) (Figure 113).
94. Repeat the above operation on the rear left brake caliper.
95. Connect the terminal to the dummy negative pole of the battery and check that the retainer is correctly coupled. Connect the IBS connector if equipped.

Service Procedure [Continued]

96. Connect the wiTECH diagnosis equipment to the vehicle data link connector of the vehicle, go to the ABS control module in the “**Miscellaneous Functions**” menu and start the “**Replace Control Module**” and “**Check Air Presence in Hydraulic System Between Control Module and Brake Caliper**” procedure.

97. Check that the value of FL - FR - RR - RL volumes shown on the diagnostics equipment are within the ranges shown in the table:

VERSION	MIN	MAX
FL (mm3)	1495	2755
FR volume (mm3)	1790	3050
RR volume (mm3)	870	1990
RL volume (mm3)	855	1975

98. If even only one of the values shown in the aforementioned table is higher than the reference threshold, repeat the bleeding procedure as instructed by the diagnosis equipment.

99. If after repeating the bleeding procedure, the maximum values for the rear calipers are still higher than the limit values, proceed as described below on the rear calipers only.

100. Find the out of tolerance caliper and remove it without disconnecting the hose.



Figure 114 – Rotate Caliper

101. Turn the brake caliper very slowly several times to the various possible positions, stop the motion and keep the bleed valve pointing upwards for a few minutes.

102. Install the brake caliper(s), then repeat the bleeding steps for the caliper(s) and check the volumes using the diagnosis equipment.

Service Procedure [Continued]

103. Close the hood.
104. Check the operation of the windshield wiper.
105. Position the right side flap of the battery housing and engage the retainers.
106. Check the operation of the electrical system.
107. Check that the time/day etc. are correct.
108. Reposition the luggage compartment lid opening cord in its housing and close the cap.
109. Install the battery cover.
110. Install the load floor cover.
111. Close the luggage compartment lid.
112. The steering must be initialized after the battery has been disconnected. This will be indicated by a warning light on the instrument panel turning on. To carry out this procedure, just start the engine, turn the steering wheel from one lock to the other and put it back into the center position.
113. Enable automatic electric handbrake engagement when the engine stops. Connect the wiTECH diagnosis equipment to the vehicle data link connector of the vehicle, select ABS “**Miscellaneous Functions**”, select “**Electric Park Brake (EPB)**” then start the “**Assembly Check**” procedure.
114. From the Connect system, switch automatic handbrake enable from ON > OFF and immediately after from OFF > ON.
115. Remove the car from the lift.

Completion Reporting and Reimbursement

Claims for vehicles that have been serviced must be submitted on the DealerCONNECT Claim Entry Screen located on the Service tab. Claims paid will be used by FCA to record recall service completions and provide dealer payments.

Use one of the following labor operation numbers and time allowances:

	Labor Operation Number	Time Allowance
Replace ABS Hydraulic Control Unit (GA, GU) (EC2-2.0L engine)	05-Y2-41-82	2.1 hours
Replace ABS Hydraulic Control Unit (GA) (EEC-2.9L engine)	05-Y2-41-83	2.5 hours
Floor Plan Reimbursement	95-95-95-97	Calculate See Below

Floor Plan Reimbursement represents the vehicle’s average daily allowance (see table below) multiplied by the number of days the vehicle was in dealer inventory and not available for sale. This reimbursement is limited to the number of days from the date of the stop sale to the date that the remedy was made available. Note: If the vehicle was received by your dealership (KZX date) AFTER the stop sale date, you will use the KZX date instead of the stop sale date. For this Recall, the stop sale was initiated on 05/04/2021.

- For the following VINs: [REDACTED] [REDACTED] remedy was made available on 06/29/2021, therefore, the number of days cannot exceed 56 days.

Vehicle	Average Daily Allowance
2020-2021 (GA) Alfa Romeo Giulia	[REDACTED]
2019-2021 (GU) Alfa Romeo Stelvio	[REDACTED]

Completion Reporting and Reimbursement [Continued]

Add the cost of the recall parts plus applicable dealer allowance to your claim.

NOTE: See the Warranty Administration Manual, Recall Claim Processing Section, for complete recall claim processing instructions.

Dealer Notification

To view this notification on DealerCONNECT, select “Global Recall System” on the Service tab, then click on the description of this notification.

Owner Notification and Service Scheduling

All involved vehicle owners known to FCA are being notified of the service requirement by first class mail. They are requested to schedule appointments for this service with their dealers. A generic copy of the owner letter is attached.

Vehicle Lists, Global Recall System, VIP and Dealer Follow Up

All involved vehicles have been entered into the DealerCONNECT Global Recall System (GRS) and Vehicle Information Plus (VIP) for dealer inquiry as needed.

GRS provides involved dealers with an updated VIN list of their incomplete vehicles. The owner's name, address and phone number are listed if known. Completed vehicles are removed from GRS within several days of repair claim submission.

To use this system, click on the “**Service**” tab and then click on “**Global Recall System.**” Your dealer's VIN list for each recall displayed can be sorted by: those vehicles that were unsold at recall launch, those with a phone number, city, zip code, or VIN sequence.

Dealers must perform this repair on all unsold vehicles before retail delivery. Dealers should also use the VIN list to follow up with all owners to schedule appointments for this repair.

Recall VIN lists may contain confidential, restricted owner name and address information that was obtained from the Department of Motor Vehicles of various states. Use of this information is permitted for this recall only and is strictly prohibited from all other use.

Additional Information

If you have any questions or need assistance in completing this action, please contact your Service and Parts District Manager.

Customer Services / Field Operations
FCA US LLC

This notice applies to your vehicle,

[Model Year and Model]

VIN XXXXXXXXXXXXXXXXXXXX

Y24/NHTSA 21V-309

LOGO

VEHICLE PICTURE

YOUR SCHEDULING OPTIONS

1. RECOMMENDED OPTION

Call your authorized Alfa Romeo dealership.

2. Call Alfa Romeo Premium Care at

1-866-932-3881. An agent can confirm part availability and help schedule an appointment.

3. Visit recalls.mopar.com, scan the

QR code below, or download the Mopar Owner's Companion App.

QR Code

Get access to recall notifications, locate your Alfa Romeo dealership, and more through this website or Mopar Owner's Companion App. You will be asked to provide your Vehicle Identification Number (VIN) to protect and verify your identity. The last eight characters of your VIN are provided above.

DEALERSHIP INSTRUCTIONS

Please reference Safety Recall Y24.

IMPORTANT SAFETY RECALL

ABS Hydraulic Control Unit

Dear [Name],

This notice is sent to you in accordance with the National Traffic and Motor Vehicle Safety Act. FCA has decided that a defect, which relates to motor vehicle safety, exists in certain [2020 and 2021 Model Year (GA) Alfa Romeo Giulia and 2019 through 2021 Model Year (GU) Alfa Romeo Stelvio] vehicles.

It is extremely important to take steps now to repair your vehicle to ensure the safety of you and your passengers.

WHY DOES MY VEHICLE NEED REPAIRS?

The Anti-Lock Brake System (ABS) Hydraulic Control Unit (HCU) on your vehicle ^[1] may have a missing or partially missing weld of the rotor to the shaft of the brushless motor. During a hard braking maneuver, the ABS HCU rotor and shaft may separate, which could lead to a reduction in braking assistance and loss of ABS functionality. Full mechanical braking is still available. **The loss of braking assistance and ABS functionality may reduce the overall braking performance which can cause a vehicle crash without prior warning.**

HOW DO I RESOLVE THIS IMPORTANT SAFETY ISSUE?

FCA will repair your vehicle ^[2] free of charge (parts and labor). To do this, your dealer will replace the suspect ABS HCU. The estimated repair time is 3 hours. In addition, your dealer will require your vehicle for proper check-in, preparation, and check-out during your visit, which require more time. Your time is important to us, so we recommend that you schedule a service appointment to minimize your inconvenience. Please bring this letter with you to your dealership.

**TO SCHEDULE YOUR FREE REPAIR,
CALL YOUR ALFA ROMEO DEALER TODAY**

WHAT IF I ALREADY PAID TO HAVE THIS REPAIR COMPLETED?

If you have already experienced this specific condition and have paid to have it repaired, you may visit www.fcarecallreimbursement.com to submit your reimbursement request online. ^[3] Once we receive and verify the required documents, reimbursement will be sent to you within 60 days. If you have had previous repairs performed and/or already received reimbursement, you may still need to have the recall repair performed.

We apologize for any inconvenience, but are sincerely concerned about your safety. Thank you for your attention to this important matter.

Customer Assistance/Field Operations
Fiat Chrysler Automobiles US LLC



Mr. Mrs. Customer
1234 Main Street
Hometown, MI 48371

[1] If you no longer own this vehicle, please help us update our records. Call Alfa Romeo Premium Care at 1-866-932-3881 to update your information.

[2] If your dealer fails or is unable to remedy this defect without charge and within a reasonable time, you may submit a written complaint to the Administrator, National Highway Traffic Safety Administration, 1200 New Jersey Ave., S.E., Washington, DC 20590, or you can call the toll-free Vehicle Safety Hotline at 1-888-327-4236 (TTY 1-800-424-9153), or go to safercar.gov.

[3] You can also mail in your original receipts and proof of payment to the following address for reimbursement consideration: FCA Customer Assistance, P.O. Box 21-8004, Auburn Hills, MI 48321-8007, Attention: Recall Reimbursement.

Note to lessors receiving this recall notice: Federal regulation requires that you forward this recall notice to the lessee within 10 days.