



April 2021

Dealer Service Instructions for:

Safety Recall Y16 / NHTSA 21V-280

Side Curtain Air Bag Fastener

Remedy Available

2020-2021 (WD) Dodge Durango

NOTE: Some vehicles above may have been identified as not involved in this recall and therefore have been excluded from this recall.

IMPORTANT: Some of the involved vehicles may be in dealer new vehicle inventory. Federal law requires you to complete this recall service on these vehicles before retail delivery. Dealers should also consider this requirement to apply to used vehicle inventory and should perform this recall on vehicles in for service. Involved vehicles can be determined by using the VIP inquiry process.

Subject

The Side Air Bag Inflatable Curtain (SABIC) on about 2700 of the above vehicles may have been built with a loose or missing fastener. A loose or missing SABIC fastener may result in an irregular SABIC deployment, which may increase the risk of occupant injury in certain types of crashes.

Service Procedure

A. Remove

WARNING: To avoid serious or fatal injury on vehicles equipped with airbags, disable the Supplemental Restraint System (SRS) before attempting any steering wheel, steering column, airbags, airbag curtains, knee blocker, seat belt tensioner, impact sensor or instrument panel component diagnosis or service. Disconnect the Intelligent Battery Sensor (IBS)/negative battery cable assembly from the negative battery post, then wait two minutes for the system capacitor to discharge before performing further diagnosis or service. This is the only sure way to disable the SRS. Failure to take the proper precautions could result in accidental airbag deployment.

NOTE: To enhance customer satisfaction, remember to reset the clock when you have completed the service procedure.

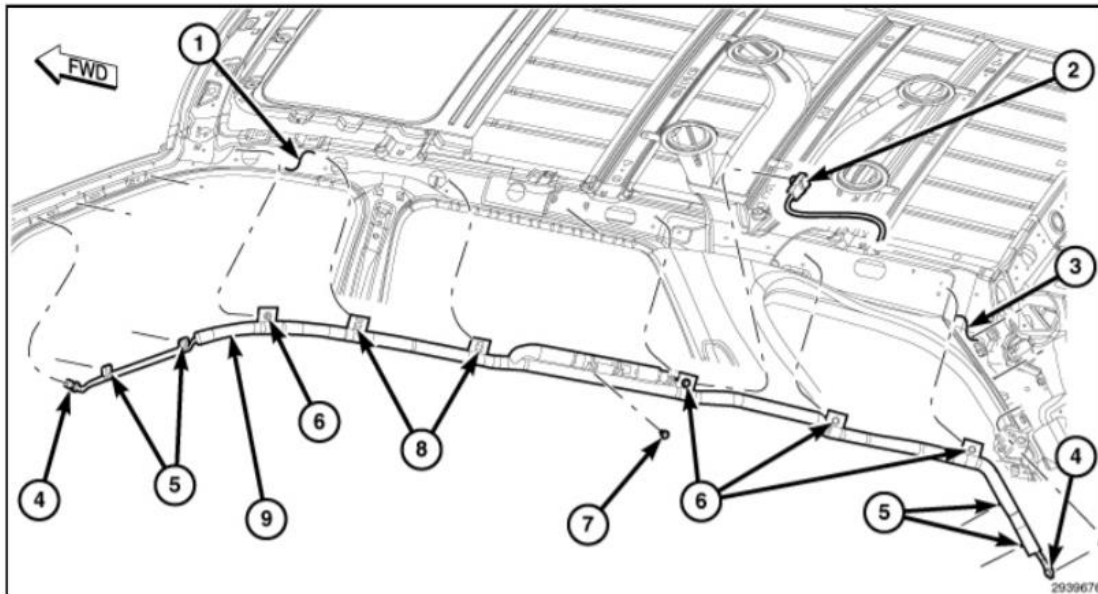

Figure 1 – Side Curtain Airbag Overview

1. Open the rear hatch.

Service Procedure [Continued]

2. Disconnect and isolate the negative battery cable. If equipped with an Intelligent Battery Sensor (IBS), disconnect the IBS connector first before disconnecting the negative battery cable. Wait two minutes for the system capacitor to discharge before further service.

3. Pull downward on the sides of the overhead console housing (1) firmly and evenly to disengage the snap clips from the overhead console bracket (Figure 2).

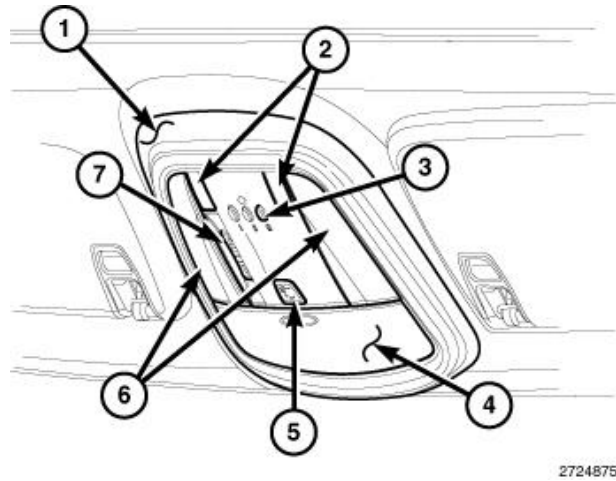

Figure 2 – Overhead Console

4. Lower the overhead console far enough to access the wire harness connectors (1) (Figure 3).

5. Disconnect the roof wire harness connectors from the connector receptacles.

6. Remove the overhead console.

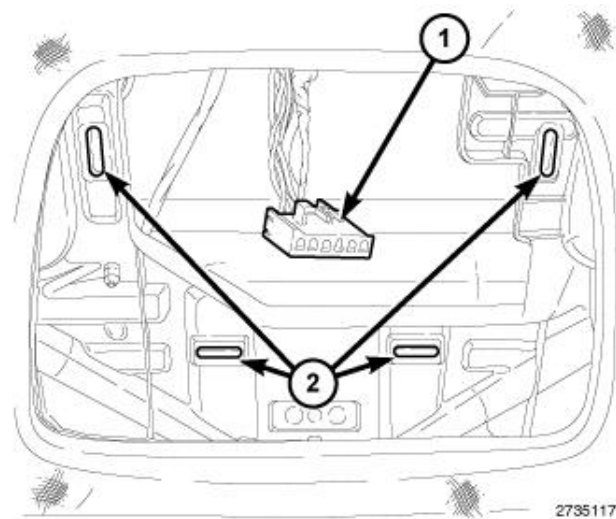

Figure 3 – Overhead Console Connector

Service Procedure [Continued]

7. Remove screw (1) from behind overhead console (Figure 4).



Figure 4 – Headliner Screw

8. Remove the grab handle screw covers (2) (Figure 5).
9. Remove the screws (1) and remove the grab handle from the headliner (Figure 5).
10. Disconnect the electrical connector, if equipped.

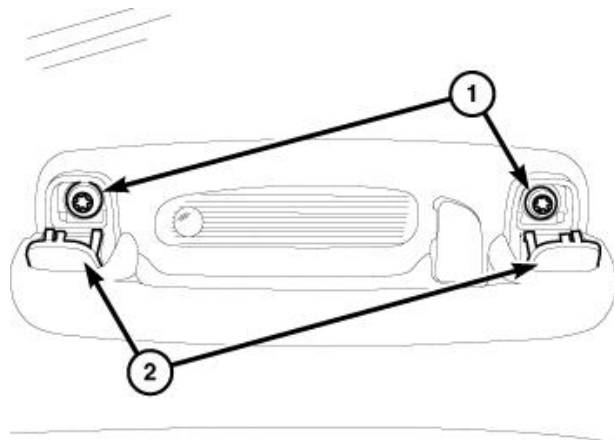

Figure 5 – Grab Handle Screw Covers

Service Procedure [Continued]

11. Open the coat hooks (2) and with a small flat blade screwdriver remove the screw covers (1) (Figure 6).

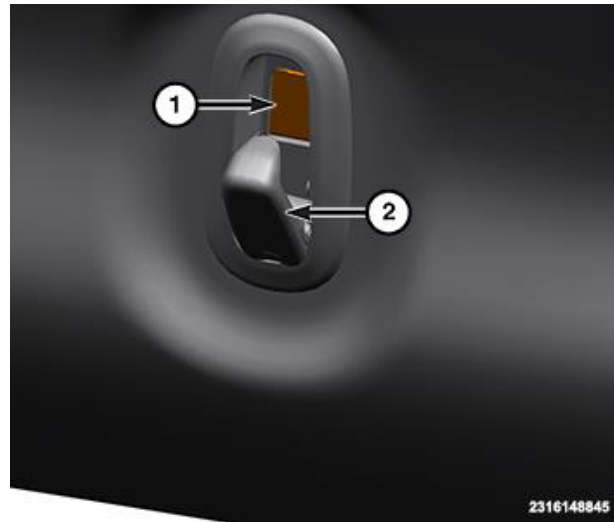

Figure 6 – Coat Hook Screw Cover

12. Remove screws (1) and remove coat hook assemblies (2) (Figure 7).

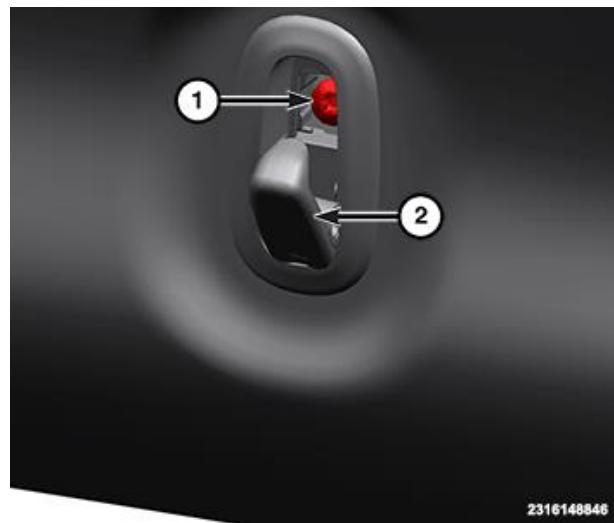

Figure 7 – Coat Hook Screw

Service Procedure [Continued]

- 13. Remove both inboard sun visor fasteners (3) and supports (2) (Figure 8).
- 14. Extend both sun visors toward the center of vehicle.

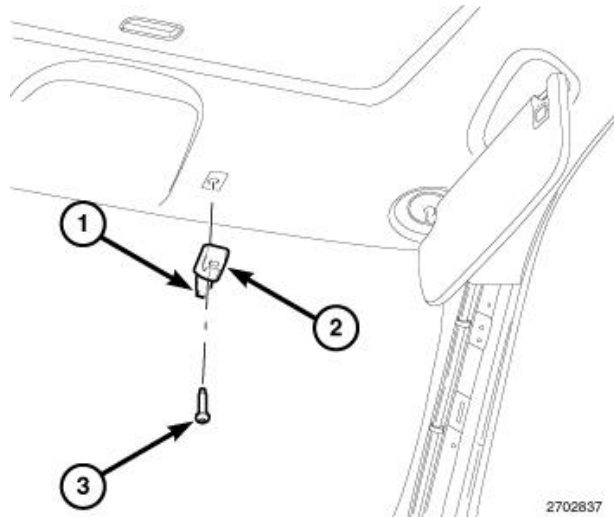

Figure 8 – Inboard Sun Visor Fasteners

- 15. Position the inboard sun visor support rod and install a tie strap (3) on both sun visors (2) to the overhead center console's roof mounted black console support bracket (1) (Figure 9).

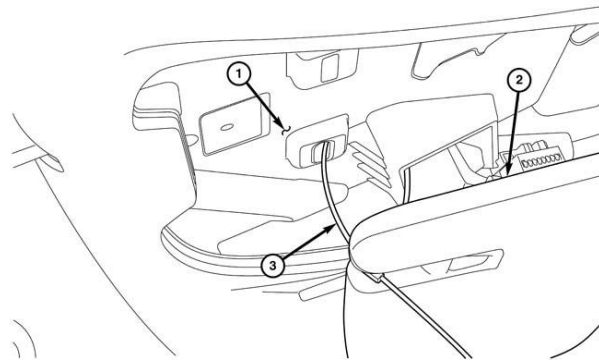
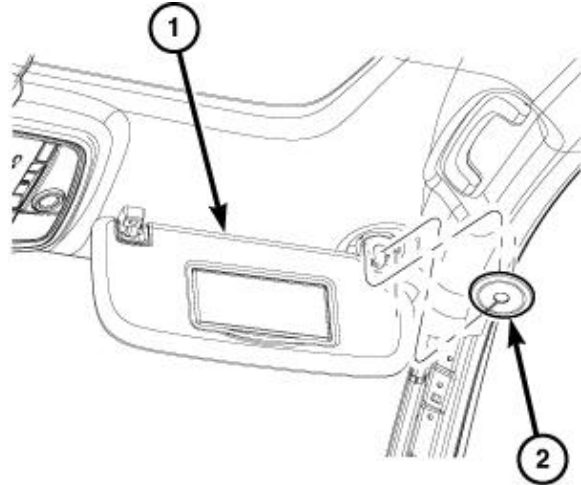

Figure 9 – Tie Strap to Overhead Console Bracket

Service Procedure [Continued]

NOTE: Visors should be rotated downward.

16. Remove visor screw covers (2). Remove all visor fasteners from both sides (Figure 10).



2702679

Figure 10 – Sun Visor Screws

17. For vehicles with a sunroof, separate the hook and loop fasteners (2) around the outside of the sunroof opening (Figure 11).

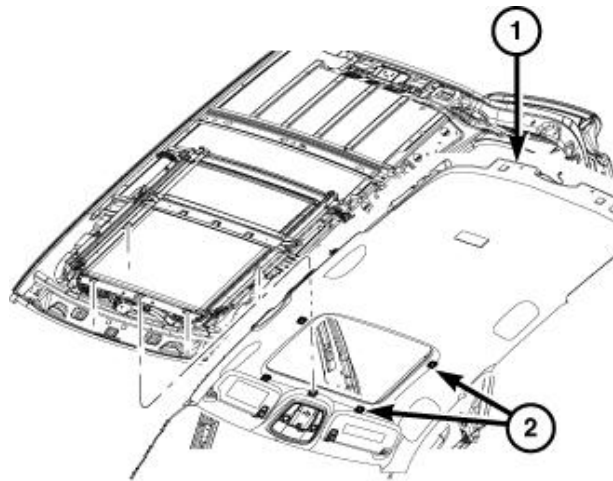

284

Figure 11 – Sun Roof Fasteners

Service Procedure [Continued]

18. Using a trim stick or equivalent, release the clips (2) and loosen the A-pillar trim panels (1) (Figure 12).

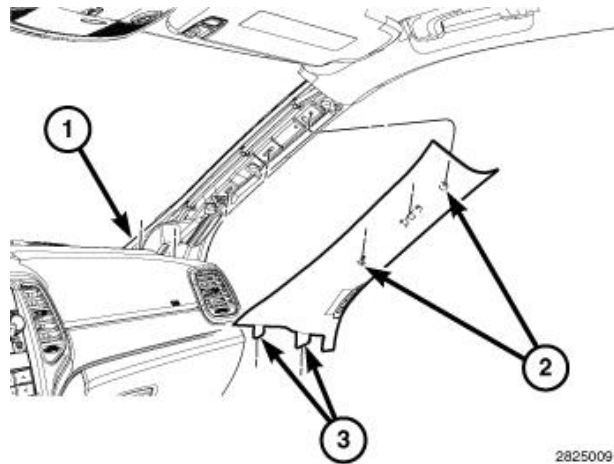

Figure 12 – A-pillar Trim

19. Using a small flat bladed tool, unclip the tether from the backside of the A-pillar trim panel and remove.
20. Temporarily connect the battery.
21. Adjust the front seat to its most forward position for easiest access to the B-pillar trim.
22. Disconnect and isolate the negative battery cable. If equipped with an Intelligent Battery Sensor (IBS), disconnect the IBS connector first before disconnecting the negative battery cable. Wait two minutes for the system capacitor to discharge before further service.
23. Using a trim stick, disengage the retaining tabs that secure all four door sill scuff plates to the retaining clips in the door sills and remove the scuff plates (Figure 13).

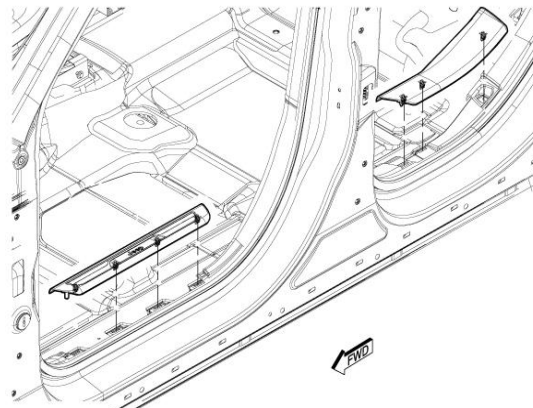

Figure 13 – Door Sill Plates

Service Procedure [Continued]

24. Separate all four door seals (1) from the door frames and position aside (Figure 14).

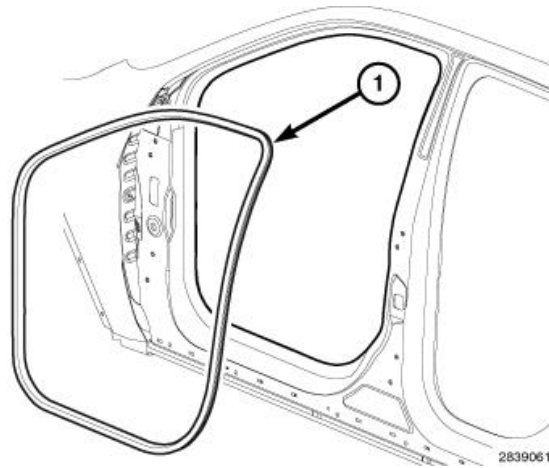

Figure 14 – Door Seal

25. Using a trim stick, disengage the retaining tabs (2) that secure the lower B-pillar trim panels (1) to the B-pillars (Figure 15).

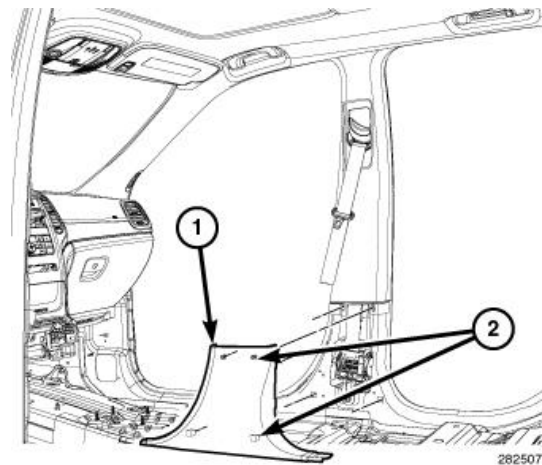

Figure 15 – Lower B-pillar Trim

Service Procedure [Continued]

26. Remove the screws (1) from the upper B-Pillar trim panels (Figure 16).
27. Using a trim stick, disengage the retaining clips that secure the upper trim panels (2) to the pillars and remove the trim panels (Figure 16).
28. Slide the trim panels down the seatbelts, away from the headliner.

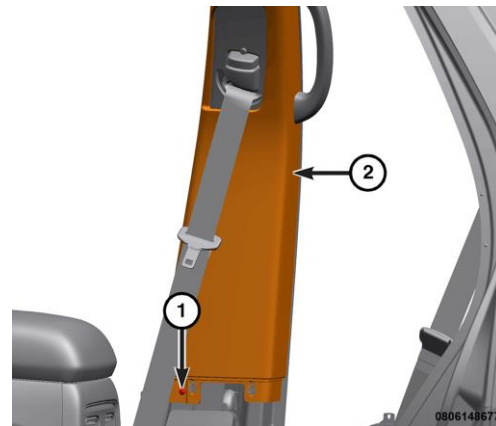

Figure 16 – Upper B-pillar Trim

NOTE: Right side shown, left side similar.

29. Fold the second and third row seats down.
30. Remove the cargo shade (if equipped).
31. Using a trim stick, disengage the retaining clips that secure the upper liftgate trim panel to the liftgate opening and remove the trim panel (3) (Figure 17).
32. If equipped, disconnect the cargo lamp electrical connector (2) (Figure 17).

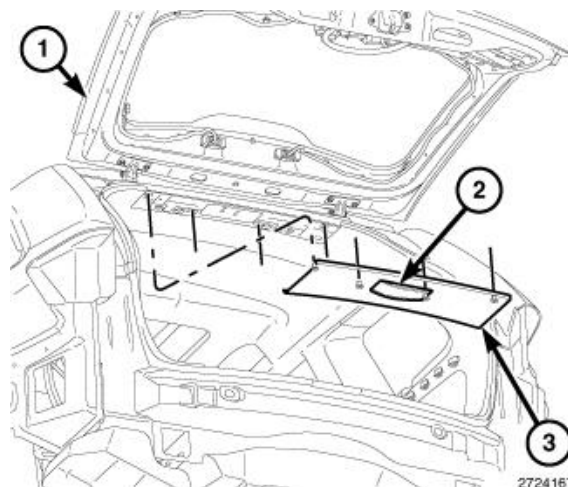

Figure 17 – Upper Liftgate Trim Panel

Service Procedure [Continued]

33. Using a trim stick, release the retaining clips (2) and separate the D-pillar trim panels (3) from the pillars (Figure 18).
34. Slide the trim panels down the seatbelts, away from the headliner (Figure 18).

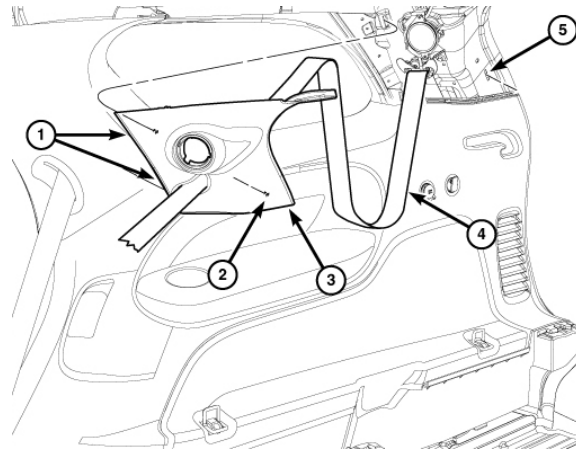

Figure 18 – D-pillar Trim

35. Open and remove the load floor lid (1) (Figure 19).

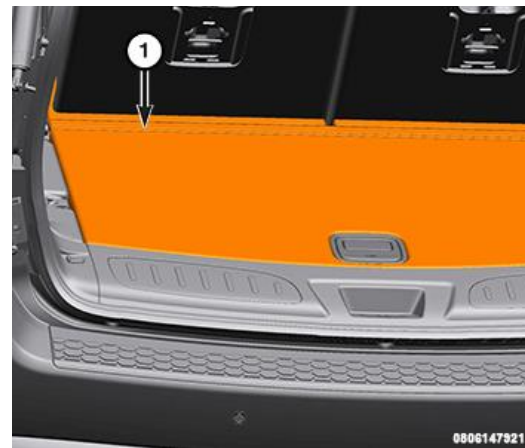

Figure 19 – Load Floor Lid

Service Procedure [Continued]

- 36. Using a trim stick, separate the retaining clips and remove the liftgate scuff plate (1) (Figure 20).

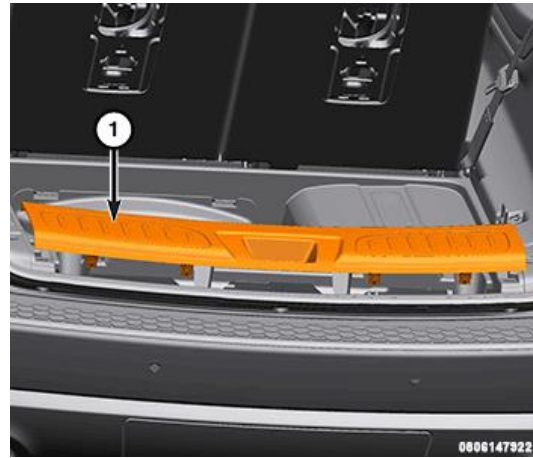

Figure 20 – Liftgate Scuff Plate

CAUTION: Failure to disconnect the wire harness connector from the antenna on the rear of the cargo load floor bin will result in damage to the antenna, antenna mounting or wire harness.

- 37. Disconnect the wire harness connector (1) from the proximity sensor (Figure 21).

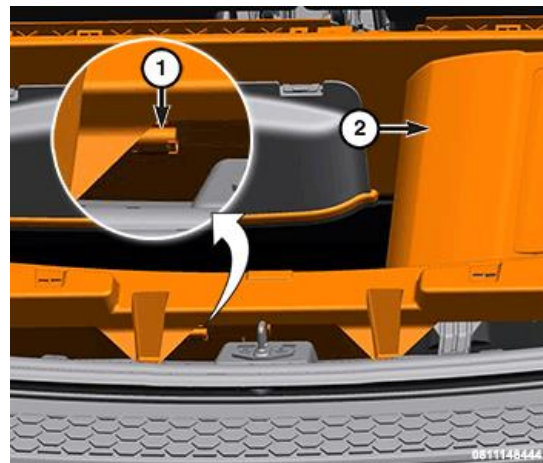

Figure 21 – Proximity Sensor Connector

Service Procedure [Continued]

38. Press the two tabs (1) down and pull out to remove jack cover (2) (Figure 22).

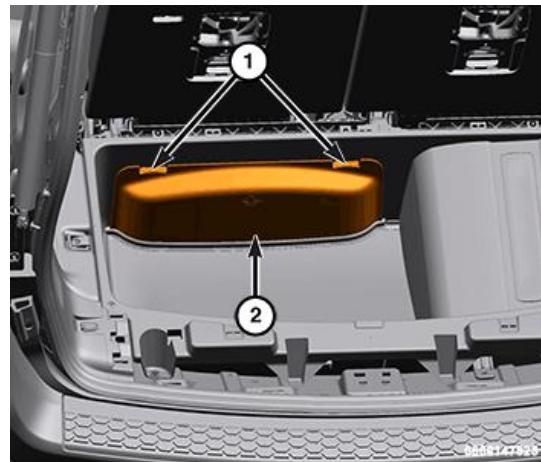

Figure 22 – Jack Cover

39. Remove the rear nuts (1) from the load floor bin (3) (Figure 23).
40. Remove the load floor bin (3) from the vehicle (Figure 23).

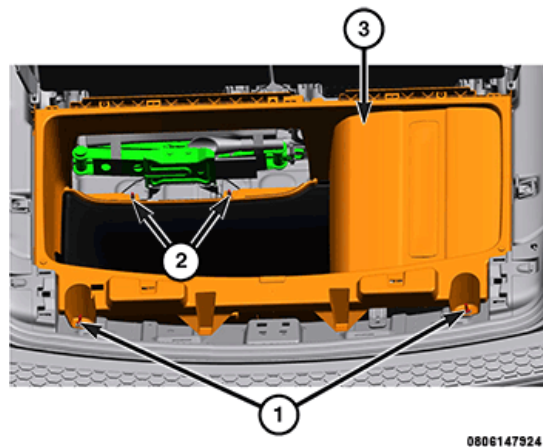

Figure 23 – Load Floor Bin Nuts

Service Procedure [Continued]

- 41. Disconnect the subwoofer wire harness connector (1) (Figure 24).
- 42. Remove the subwoofer fasteners (2) (Figure 24).
- 43. Remove the subwoofer (3) (Figure 24).

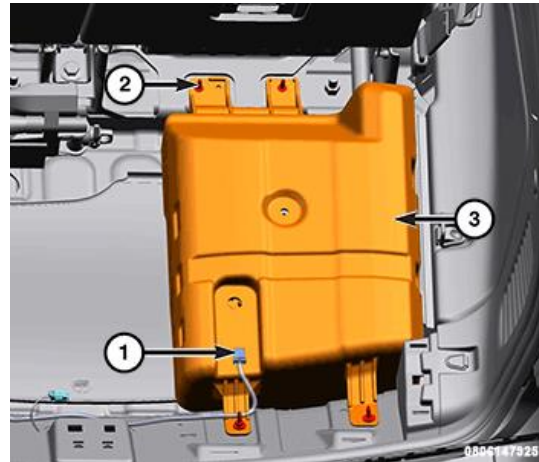

Figure 24 – Subwoofer Connector

- 44. Using a small flat bladed tool, remove the screw caps (3) from the quarter panel trim panels (Figure 25).
- 45. Remove the screws (4) (Figure 25).
- 46. Using a trim stick, disengage the retaining fasteners (5) that secure the quarter trim panels to the quarter panels (Figure 25).

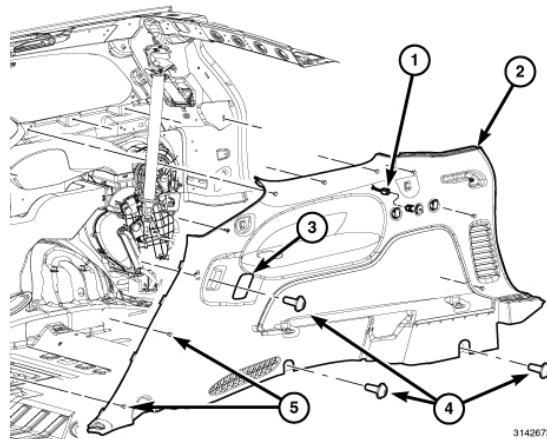

Figure 25 – Quarter Panel Trim

- 47. Pull the quarter trim panels away from the quarter panels (Figure 25).
- 48. If equipped, disconnect the power outlet wire harness connector (1) (Figure 25).
- 49. For the left side, disconnect the flash light electrical connector and the power liftgate switch, if equipped.

Service Procedure [Continued]

50. Remove the quarter trim panels (2) (Figure 25).

51. Remove screws (1) from C-Pillar trim panels (2) (Figure 26).

52. Using a trim stick, disengage the retaining clips that secure the C-pillar trim panels to the pillars and remove the trim panels (Figure 26).

53. Slide the trim panels down the seatbelt, away from the headliner.



Figure 26 – C-pillar Trim

54. Remove the headliner trim panel screws (4) (Figure 27).

55. Using a trim stick, disengage the retaining clips that secure the headliner trim panels (2) to the body (Figure 27).

56. Release the tethers from the trim panels and remove the headliner trim panels (2) (Figure 27).

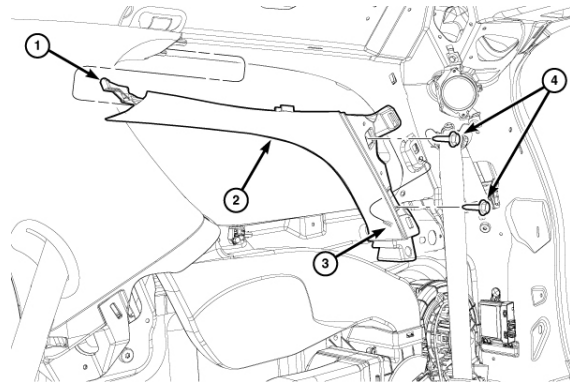

Figure 27 – Headliner Trim

Service Procedure [Continued]

57. Using a trim stick, remove the upper mirror trim cover (1) (Figure 28).



Figure 28 – Upper Mirror Trim

58. Using trim stick separate the sides of the lower trim cover and gently pull down and remove the lower mirror trim (1) (Figure 29).
59. Release the wire harness connector and position the wire harness aside.

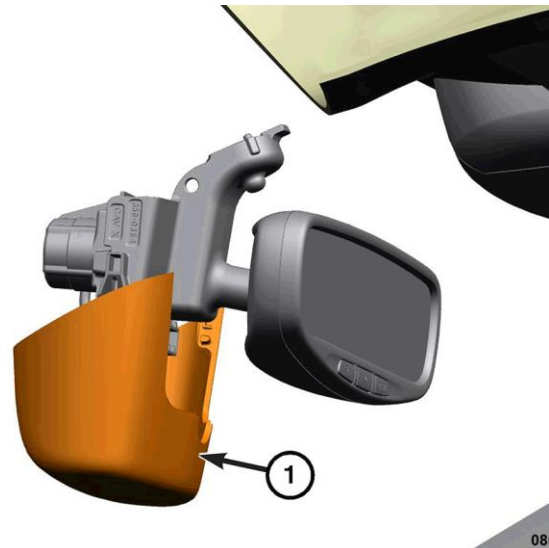

Figure 29 – Lower Mirror Trim

Service Procedure [Continued]

60. Twist the mirror assembly (1) clockwise and release the mirror from the aluminum button (2) attached to the windshield (Figure 30).
61. Temporarily connect the battery.
62. Adjust the front seat to support the headliner.
63. Disconnect and isolate the negative battery cable. If equipped with an Intelligent Battery Sensor (IBS), disconnect the IBS connector first before disconnecting the negative battery cable. Wait two minutes for the system capacitor to discharge before further service.
64. Remove the two rear headliner push pin fasteners (2) (Figure 31).

CAUTION: Be careful not to crease the headliner.

65. Pull down the headliner.

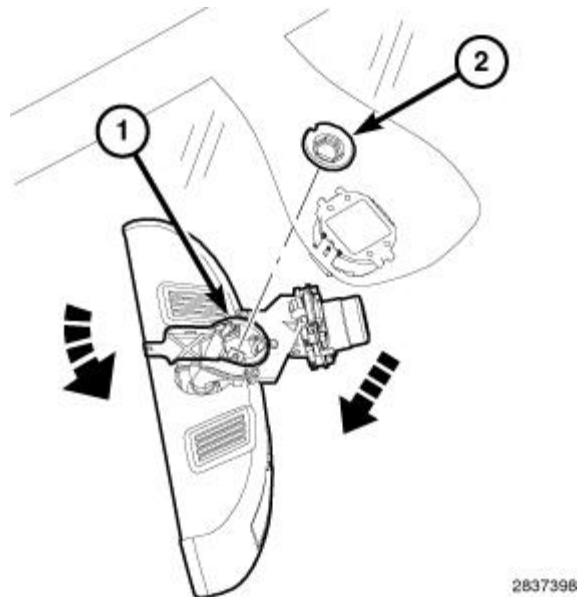

Figure 30 – Twist Mirror

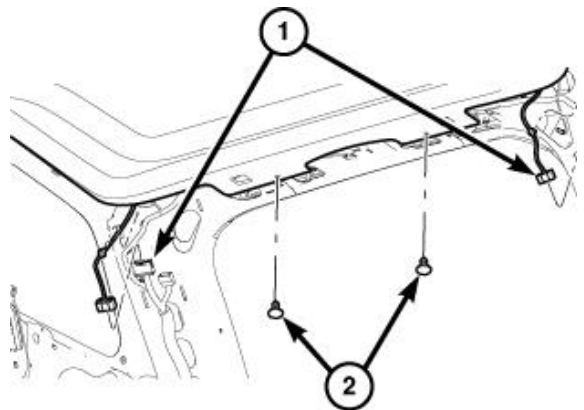
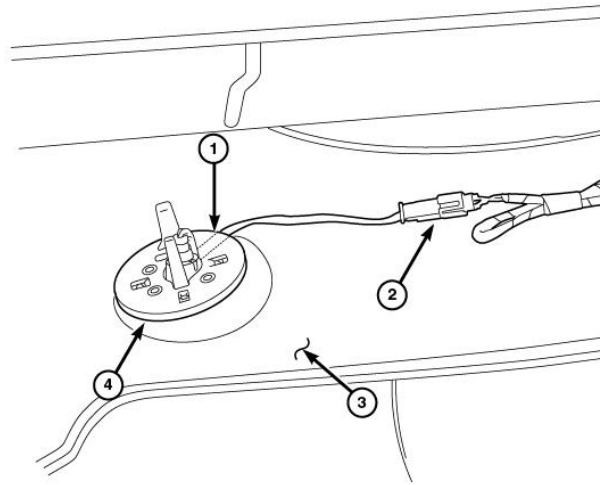
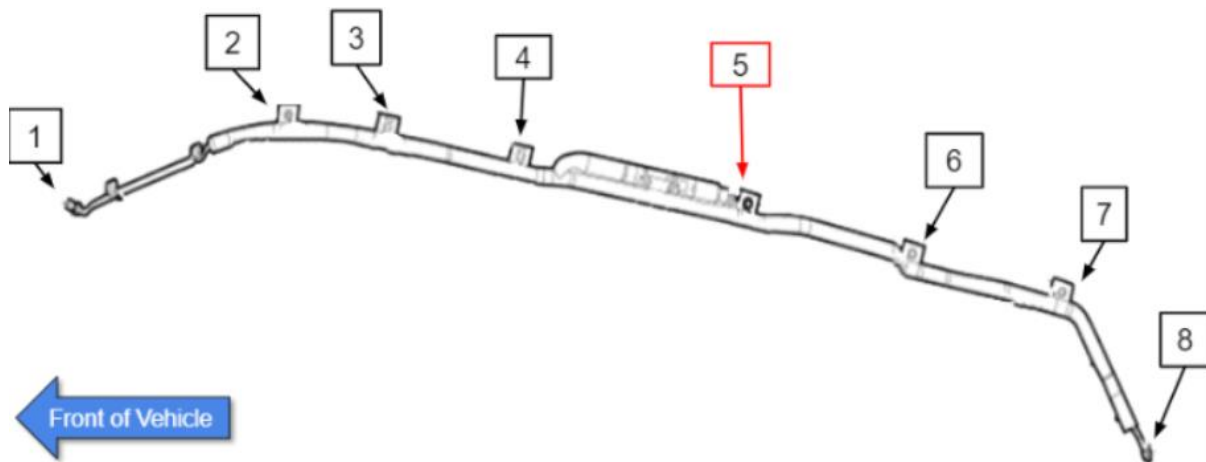

Figure 31 – Headliner Push Pins

Service Procedure [Continued]

66. Remove the white colored 'top hat' clips (4) from the roof header carefully, as they need to be re-used (if the clips break, new clips will be required for installation) (Figure 32).
67. Lower the headliner to access the SABIC fasteners. Do not remove the headliner.

**Figure 32 – Remove 'Top Hat' Clip**

Service Procedure [Continued]**A. Install****Figure 33 – Eight SABIC Fasteners**

68. Verify that all eight SABIC fasteners are present per side. If fasteners are missing, they must be replaced using the proper MOPAR part number fasteners. The fastener listed in the parts section (5) is the one most often missing, and is longer than the others (Figure 33). The other fasteners are a different part number, and not expected to be missing.
69. Once the presence of all fasteners is confirmed, torque all fasteners on both sides to 9 N·m (80 in. lbs.).
70. Install the white colored 'top hat' clip (4) to the sun visors and roof header carefully. If the clip breaks a new one will be required for installation (Figure 32).

CAUTION: Be careful not to crease the headliner.

71. Lift the headliner.
72. Install the two rear headliner push pin fasteners (2) (Figure 31).
73. Temporarily connect the battery.
74. Adjust the front seat away from the headliner.

Service Procedure [Continued]

75. Disconnect and isolate the negative battery cable. If equipped with an Intelligent Battery Sensor (IBS), disconnect the IBS connector first before disconnecting the negative battery cable. Wait two minutes for the system capacitor to discharge before further service.
76. Twist the mirror assembly (1) clockwise and release the mirror from the aluminum button (2) attached to the windshield (Figure 30).
77. Connect the wire harness connector and position the wire harness aside.
78. Align the sides of the lower trim cover and gently push up and install the lower mirror trim (1) (Figure 29).
79. Align and install the upper mirror trim cover (1) (Figure 28).
80. Install the tether to the trim panels and place the headliner trim panels in position (2) (Figure 27).
81. Align and seat the retaining clips that secure the headliner trim panels (2) to the body (Figure 27).
82. Install the headliner trim screws (4) (Figure 27).
83. Slide the C-pillar trim panels up the seatbelt, toward the headliner (Figure 26).
84. Seat the retaining clips that secure the C-pillar trim panels to the pillars (Figure 26).
85. Install the screws (1) to C-Pillar trim panels (2) (Figure 26).
86. Position the quarter trim panels (2) to the vehicle (Figure 25).
87. For the left side, connect the flash light electrical connector and the power liftgate switch, if equipped.
88. If equipped, connect the power outlet wire harness connector (1) (Figure 25).
89. Press the quarter trim panels into place on the quarter panels (Figure 25).

Service Procedure [Continued]

90. Engage the retaining fasteners (5) that secure the quarter trim panels to the quarter panels (Figure 25).
91. Install the screws (4) (Figure 25).
92. Install the screw cap (3) from the quarter panel trim panels (Figure 25).
93. Install the subwoofer (3) (Figure 24).
94. Install the subwoofer fasteners (2) (Figure 24).
95. Connect the subwoofer wire harness connector (1) (Figure 24).
96. Install the load floor bin (3) to the vehicle (Figure 23).
97. Install the rear nuts (1) to the load floor bin (3) (Figure 23).
98. Install the jack cover (2) (Figure 22).
99. Connect the wire harness connector (1) to the proximity sensor (Figure 21).
100. Align the retaining clips and seat the lift-gate scuff plate (1) (Figure 20).
101. Install and close the load floor lid (1) (Figure 19).
102. Slide the D-pillar trim panels up the seatbelt, toward the headliner (Figure 18).
103. Align the retaining clips (2) and seat the D-pillar trim panels (3) to the pillars (Figure 18).
104. If equipped, connect the cargo lamp electrical connector (2) (Figure 17).
105. Seat the retaining clips that secure the upper liftgate trim panel to the liftgate opening (3) (Figure 17).

Service Procedure [Continued]

106. Install the cargo shade (if equipped).
107. Fold the second and third row seats up.
108. Slide the B-pillar trim panels up the seatbelt, toward the headliner (Figure 16).
109. Seat the retaining clips that secure the upper trim panels (2) to the pillars (Figure 16).
110. Install the screws (1) to the upper B-Pillar trim panels (Figure 16).
111. Seat the retaining tabs (2) that secure the lower B-pillar trim panels (1) to the B-pillars (Figure 15).
112. Install all four door seals (1) to the door frames (Figure 14).
113. Seat the retaining tabs that secure the door sill scuff plates to the retaining clips in the door sills and remove the scuff plates (Figure 13).
114. Temporarily connect the battery.
115. Adjust the front seat to its most forward position for easiest access to the B-pillar trim.
116. Disconnect and isolate the negative battery cable. If equipped with an Intelligent Battery Sensor (IBS), disconnect the IBS connector first before disconnecting the negative battery cable. Wait two minutes for the system capacitor to discharge before further service.
117. Clip the tether to the backside of the A-pillar trim panels (Figure 12).
118. Align the clips (2) and seat the A-pillar trim panels (1) (Figure 12).
119. For vehicles with a sunroof, seat the hook and loop fasteners (2) around the outside of the sunroof opening (Figure 11).
120. Install all visor fasteners to both sides. Install visor screw covers (2) (Figure 10).

Service Procedure [Continued]

121. Remove the tie straps (3) from both sun visors (2) at the overhead center console's roof mounted black console support bracket (1) (Figure 9).
122. Install both inboard sun visor fasteners (3) and supports (2) (Figure 8).
123. Install screws (1) and remove coat hook assemblies (2) (Figure 7).
124. Open the coat hooks (2) and with a small flat blade screwdriver install the screw covers (1) (Figure 6).
125. Connect the grab handle electrical connector, if equipped (Figure 5).
126. Install the screws (1) and the grab handle to the headliner (Figure 5).
127. Install the grab handle screw covers (2) (Figure 5).
128. Install the screw (1) to the overhead console (Figure 4).
129. Set the overhead console in place.
130. Connect the roof wire harness connectors from the connector receptacles (Figure 3).
131. Push upward on the sides of the overhead console housing (1) firmly and evenly to engage the snap clips to the overhead console bracket (Figure 2).

NOTE: The following procedure should be performed using a diagnostic scan tool to verify proper Supplemental Restraint System (SRS) operation following the service or replacement of any SRS component. Refer to the appropriate diagnostic procedures.

132. During the following test, the negative cable remains disconnected and isolated from the battery, as it was during the Supplemental Restraint System (SRS) component removal and installation procedures.

Service Procedure [Continued]

133. Be certain that the diagnostic scan tool contains the latest version of the proper diagnostic software. Connect the scan tool to the 16-way Data Link Connector (DLC) (1). The DLC is located on the driver side lower edge of the instrument panel (2), outboard of the steering column (Figure 34).
134. Transition the status of the ignition switch to ON and exit the vehicle with the scan tool.
135. Check to be certain that nobody is in the vehicle, then connect the negative cable to the battery.
136. Using the scan tool, read and record the active (current) Diagnostic Trouble Code (DTC) data.
137. Use the scan tool to read and record any stored (historical) DTC data.
138. If any DTC is found in Step 5 or Step 6, refer to the appropriate diagnostic information.
139. Use the scan tool to erase the stored DTC data. If any problems remain, the stored DTC data will not erase. Refer to the appropriate diagnostic information to diagnose any stored DTC that will not erase. If the stored DTC information is successfully erased, go to the next step.
140. Transition the status of the ignition switch to OFF for about 15 seconds, and then back to ON. Observe the airbag indicator in the instrument cluster. It should light for six to eight seconds, and then go out. This indicates that the SRS is functioning normally and that the repairs are complete. If the airbag indicator fails to light, or lights and stays ON, there is still an active SRS fault or malfunction. Refer to the appropriate diagnostic information to diagnose the problem.

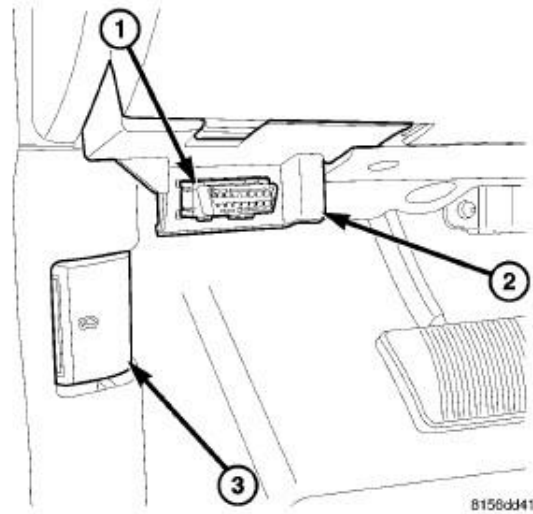
**Figure 34 – Data Link Connector**

Completion Reporting and Reimbursement

Claims for vehicles that have been serviced must be submitted on the DealerCONNECT Claim Entry Screen located on the Service tab. Claims paid will be used by FCA to record recall service completions and provide dealer payments.

Use one of the following labor operation numbers and time allowances:

	Labor Operation Number	Time Allowance
Verify Fastener Torque on Left and Right Side Curtain Airbags	23-Y1-61-82	2.6 hours

Optional Equipment

Overhead Console Equipped	23-Y1-61-60	0.2 hours
DVD Monitor Equipped	23-Y1-61-62	0.2 hours

In addition, enter “MATL” in the Part Number section of your claim with the applicable Material Allowance where appropriate.

NOTE: See the Warranty Administration Manual, Recall Claim Processing Section, for complete recall claim processing instructions.

Dealer Notification

To view this notification on DealerCONNECT, select “Global Recall System” on the Service tab, then click on the description of this notification.

Owner Notification and Service Scheduling

All involved vehicle owners known to FCA are being notified of the service requirement by first class mail. They are requested to schedule appointments for this service with their dealers. A generic copy of the owner letter is attached.

Vehicle Lists, Global Recall System, VIP and Dealer Follow Up

All involved vehicles have been entered into the DealerCONNECT Global Recall System (GRS) and Vehicle Information Plus (VIP) for dealer inquiry as needed.

GRS provides involved dealers with an updated VIN list of their incomplete vehicles. The owner's name, address and phone number are listed if known. Completed vehicles are removed from GRS within several days of repair claim submission.

To use this system, click on the “**Service**” tab and then click on “**Global Recall System.**” Your dealer's VIN list for each recall displayed can be sorted by: those vehicles that were unsold at recall launch, those with a phone number, city, zip code, or VIN sequence.

Dealers must perform this repair on all unsold vehicles before retail delivery. Dealers should also use the VIN list to follow up with all owners to schedule appointments for this repair.

Recall VIN lists may contain confidential, restricted owner name and address information that was obtained from the Department of Motor Vehicles of various states. Use of this information is permitted for this recall only and is strictly prohibited from all other use.

Additional Information

If you have any questions or need assistance in completing this action, please contact your Service and Parts District Manager.

Customer Services / Field Operations
FCA US LLC

This notice applies to your vehicle,

[Model Year and Model]

VIN XXXXXXXXXXXXXXXXXXXX

Y16/NHTSA 21V-280

LOGO

VEHICLE PICTURE

YOUR SCHEDULING OPTIONS

- 1. RECOMMENDED OPTION**
Call your authorized Chrysler / Dodge / Jeep® / RAM Dealership
- 2. Call the FCA Recall Assistance Center at 1-800-853-1403.** An agent can confirm part availability and help schedule an appointment
- 3. Visit recalls.mopar.com, scan the QR code below, or download the Mopar Owner's Companion App.**

QR Code

Get access to recall notifications, locate your nearest dealer, and more through this website or Mopar Owner's Companion App. You will be asked to provide your Vehicle Identification Number (VIN) to protect and verify your identity. The last eight characters of your VIN are provided above.

DEALERSHIP INSTRUCTIONS

Please reference Safety Recall Y16.

IMPORTANT SAFETY RECALL

Side Curtain Air Bag Fastener

Dear [Name],

This notice is sent to you in accordance with the National Traffic and Motor Vehicle Safety Act.

FCA US has decided that a defect, which relates to motor vehicle safety, exists in certain [2020 and 2021 (WD) Dodge Durango] vehicles.

It is extremely important to take steps now to repair your vehicle to ensure the safety of you and your passengers.

WHY DOES MY VEHICLE NEED REPAIRS?

The Side Air Bag Inflatable Curtain (SABIC) on your vehicle ^[1] may have been built with a loose or missing fasteners. **A loose or missing SABIC fastener may result in an irregular SABIC deployment, which may increase the risk of occupant injury in certain types of crashes.**

HOW DO I RESOLVE THIS IMPORTANT SAFETY ISSUE?

FCA US will repair your vehicle ^[2] free of charge (parts and labor). To do this, your dealer will inspect the C-pillar SABIC fastener. Vehicles found with a missing SABIC fastener will have a new fastener installed and tightened to the proper torque specification. Vehicles that do not have a missing SABIC fastener will be inspected for proper torque, and tightened to specification if required. The estimated repair time is three hours. In addition, your dealer will require your vehicle for proper check-in, preparation, and check-out during your visit, which may require more time. Your time is important to us, so we recommend that you schedule a service appointment to minimize your inconvenience. Please bring this letter with you to your dealership.

**TO SCHEDULE YOUR FREE REPAIR,
CALL YOUR CHRYSLER, DODGE, JEEP OR RAM DEALER TODAY**

WHAT IF I ALREADY PAID TO HAVE THIS REPAIR COMPLETED?

If you have already experienced this specific condition and have paid to have it repaired, you may visit www.fcarecallreimbursement.com to submit your reimbursement request online. ^[3] Once we receive and verify the required documents, reimbursement will be sent to you within 60 days. If you have had previous repairs performed and/or already received reimbursement, you may still need to have the recall repair performed.

We apologize for any inconvenience, but are sincerely concerned about your safety. Thank you for your attention to this important matter.

Customer Assistance/Field Operations
FCA US LLC



Mr. Mrs. Customer
1234 Main Street
Hometown, MI 48371

[1] If you no longer own this vehicle, please help us update our records. Call the FCA Recall Assistance Center at 1-800-853-1403 to update your information.

[2] If your dealer fails or is unable to remedy this defect without charge and within a reasonable time, you may submit a written complaint to the Administrator, National Highway Traffic Safety Administration, 1200 New Jersey Ave., S.E., Washington, DC 20590, or you can call the toll-free Vehicle Safety Hotline at 1-888-327-4236 (TTY 1-800-424-9153), or go to safercar.gov.

[3] You can also mail in your original receipts and proof of payment to the following address for reimbursement consideration: FCA Customer Assistance, P.O. Box 21-8004, Auburn Hills, MI 48321-8007, Attention: Recall Reimbursement.

Note to lessors receiving this recall notice: Federal regulation requires that you forward this recall notice to the lessee within 10 days.