

July 30, 2021

Version 4

Safety Recall: 2019-20 Insight Fuel Pump MotorSupersedes 21-032, dated April 10, 2021, to revise the information highlighted in **yellow**.**AFFECTED VEHICLES**

Year	Model	Trim Level	VIN Range
2019-20	Insight	ALL	Check the iN VIN status for eligibility.

REVISION SUMMARY**Under REPAIR PROCEDURE, steps 18, 19, 28, 29, 30, and 31 were revised.****BACKGROUND**

Due to swelling of the fuel pump motor impeller, the fuel pump may seize and stop working. If this occurs, the check engine light may be displayed with DTC P0087 (Fuel Rail Pressure Too Low) stored, the engine may not start, or the engine could stall while driving, increasing the risk of a crash.

CUSTOMER NOTIFICATION

Owners of affected vehicles will be sent a notification of this campaign.

Do an iN VIN status inquiry to make sure the vehicle is shown as eligible.

Some vehicles affected by this campaign may be in your new or used vehicle inventory.

Failure to repair a vehicle subject to a recall or campaign may subject your dealership to claims or lawsuits from the customer or anyone else harmed as a result of such failure. To see if a vehicle in inventory is affected by this safety recall, do a VIN status inquiry before selling it.

CORRECTIVE ACTION

Replace the fuel pump motor.

PARTS INFORMATION

NOTE: Due to limited supply, this is a controlled part and will require a valid VIN when ordering.

Part Name	Part Number	Quantity
Fuel Pump Motor Kit	06170-TXM-305	1

For dealers experiencing a strong fuel smell from storing a fuel pump motor replaced under this service bulletin, the fuel pump motor may be disposed of immediately in accordance with local regulations. This only applies to the fuel pump motor replaced under this service bulletin. The published retention policy remains in effect for all other parts.

If you have any questions about this exception or other parts retention issues, contact the WPI Administrative Office at **937-642-2737**.

CUSTOMER INFORMATION: The information in this bulletin is intended for use only by skilled technicians who have the proper tools, equipment, and training to correctly and safely maintain your vehicle. These procedures should not be attempted by "do-it-yourselfers," and you should not assume this bulletin applies to your vehicle, or that your vehicle has the condition described. To determine whether this information applies, contact an authorized Honda automobile dealer.

TOOL INFORMATION

Tool Name	Part Number	Quantity
Fuel Sender Wrench	070AA-TLA0100	1

WARRANTY CLAIM INFORMATION

Operation Number	Description	Flat Rate Time	Defect Code	Symptom Code	Template ID	Failed Part Number
3101HK	Replace the fuel pump motor, and do the VSA sensor neutral position memorization procedure.	1.1 hr	6FE00	YAH00	A21032A	17045-TXM-A00

Skill Level: Repair Technician

REPAIR PROCEDURE

⚠ WARNING

Fuel pump motor removal exposes fuel, which can ignite, causing a fire or explosion. This can cause serious injury or death. Always work in a well-ventilated area, and keep sparks or open flames away.

1. Remove the fuel fill cap.
2. Relieve the fuel pressure.

With an i-HDS:

- Connect an i-HDS to the vehicle.
- Turn the vehicle to ON.
- Select the **PGM-FI** system on the i-HDS.
- Select **FUEL PUMP OFF** from the **Function Test** menu.
- Turn the vehicle to OFF.

Without an i-HDS: Remove the PGM-FI main relay 2.

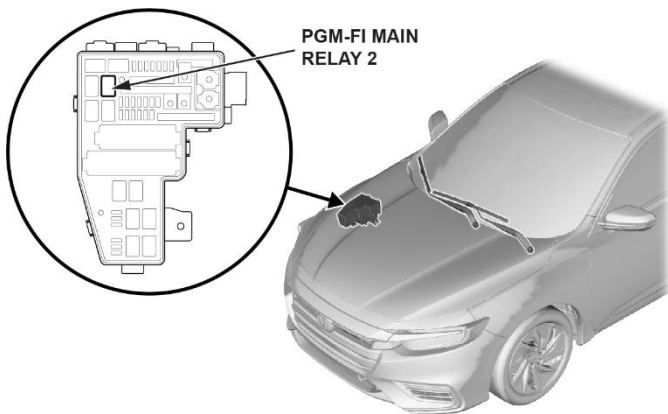

3. Do the following within 60 seconds to start the engine in PGM-FI maintenance mode.
 - Turn the vehicle to ON without stepping on the brake pedal.
 - With the shift position in P, press the accelerator pedal to the floor twice.
 - Press the brake pedal, shift the transmission to N, then press the accelerator pedal to the floor twice.
 - Press the brake pedal, shift the transmission to P, then press the accelerator pedal to the floor twice. The vehicle is now in maintenance mode and **Maintenance Mode** will be displayed on the MID.
 - Press the brake pedal, and turn the vehicle to ON. The engine will start in maintenance mode.

NOTE:

- If the engine coolant temperature is too hot, the engine may not start until the engine coolant temperature drops.
- To stop the engine and cancel maintenance mode, turn the vehicle to OFF.
- The VSA operates normally while the vehicle is in maintenance mode.
- During cold starts in maintenance mode, there may be some additional transmission noise. This is normal.
- When starting the engine in maintenance mode, you may hear a groan/rattle for the first minute or when the engine decelerates. This noise is caused by gear tolerances when the generator is not under load. This noise is considered normal while in maintenance mode.

4. Let the engine idle until it stalls.
5. Turn the vehicle to OFF.

NOTE:

- The engine may start again momentarily and stall if you do not turn the vehicle to OFF.
- Do not turn the vehicle to ON after turning it OFF.

6. If the PGM-FI main relay 2 was removed in step 2, install it now.
7. Remove the center console side panel.

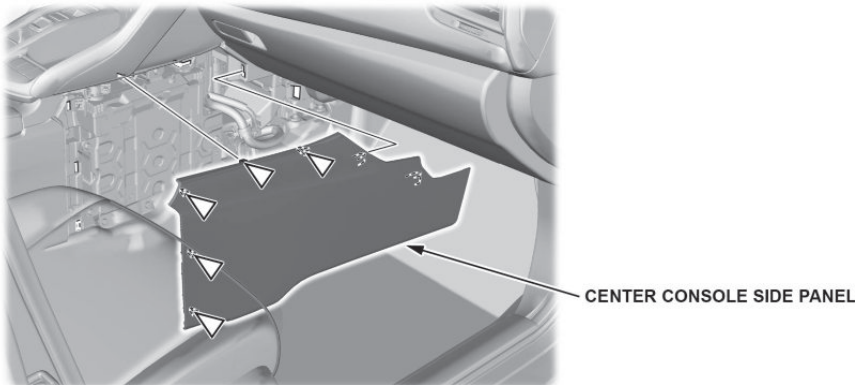

8. Disconnect the 12-volt battery negative terminal.

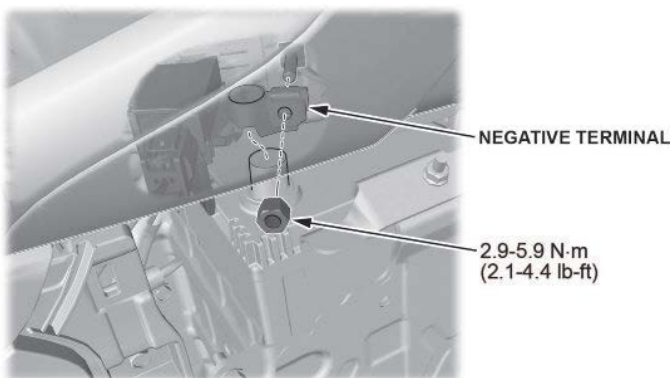

9. Fold down the rear seat-back.
10. Turn over the bottom of the rear seat-back cover, then remove the bolts.

Split fold down seat: Remove the right-rear seat-back.

Split fold down seat

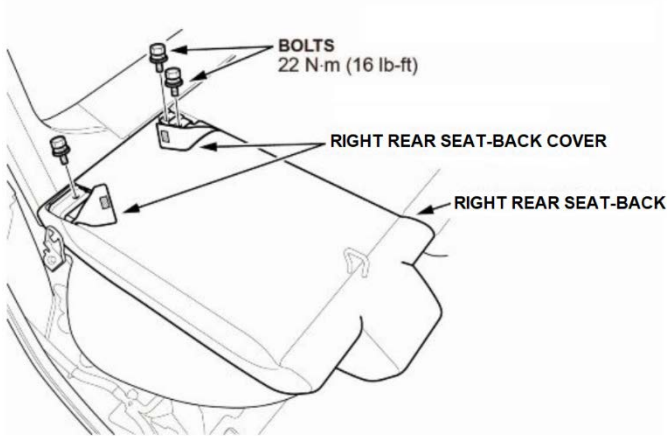

Fold down seat

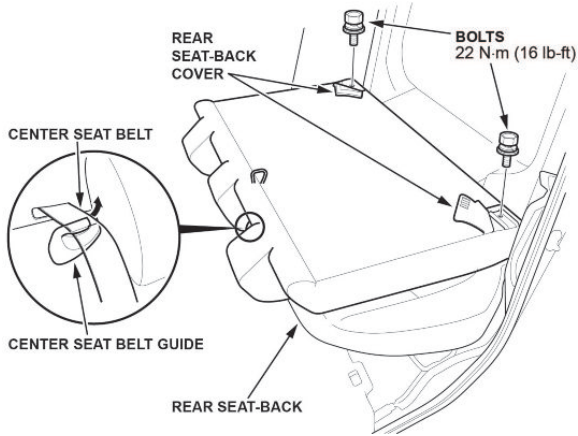

11. Pull out the center seat belt through the slit in the center seat belt guide.

Split fold down seat: Remove the left-rear seat-back.

Fold down seat: Remove the rear seat-back.

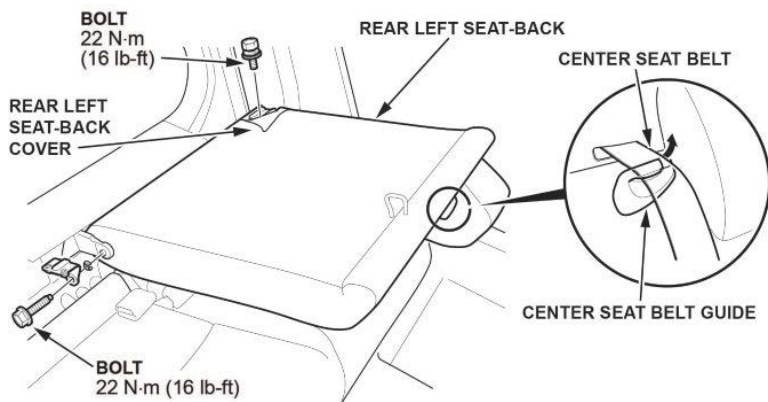

12. Remove the rear seat cushion bolt.

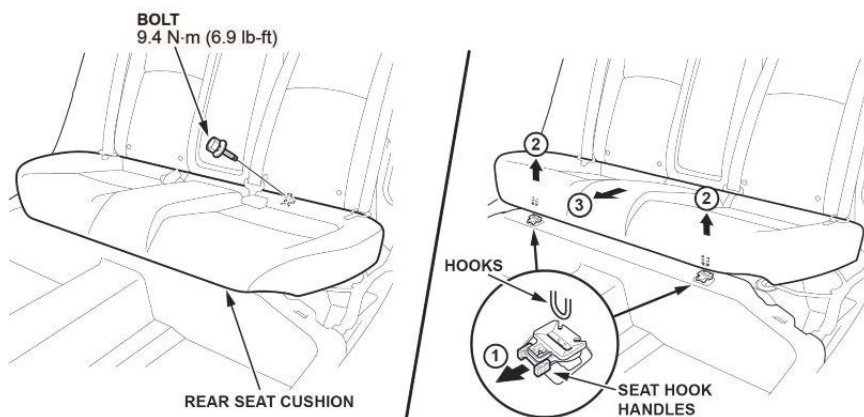

13. While pushing down on the seat cushion, pull the seat hook handles to release the hooks.

14. Remove the rear seat cushion.

15. Remove the fuel tank unit access panel and disconnect the connector.

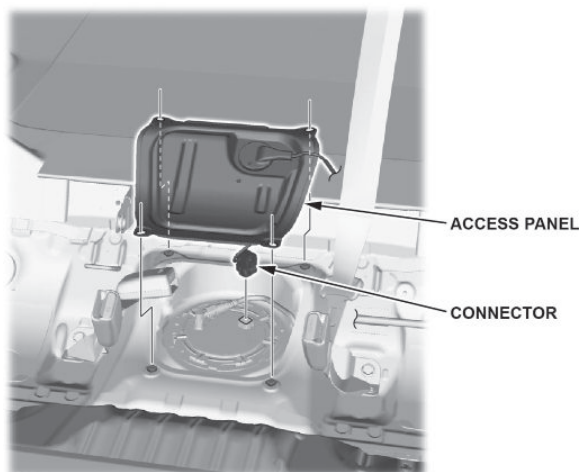

16. Place a rag or shop towel over the quick-connect fitting, and disconnect it.

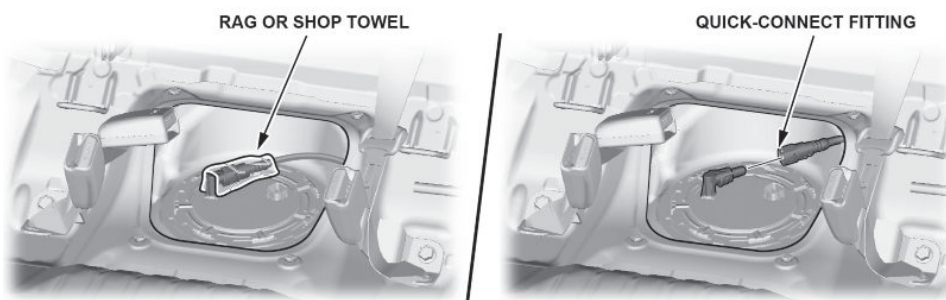

17. Set the fuel sender wrench (070AA-TLA0100) as shown.

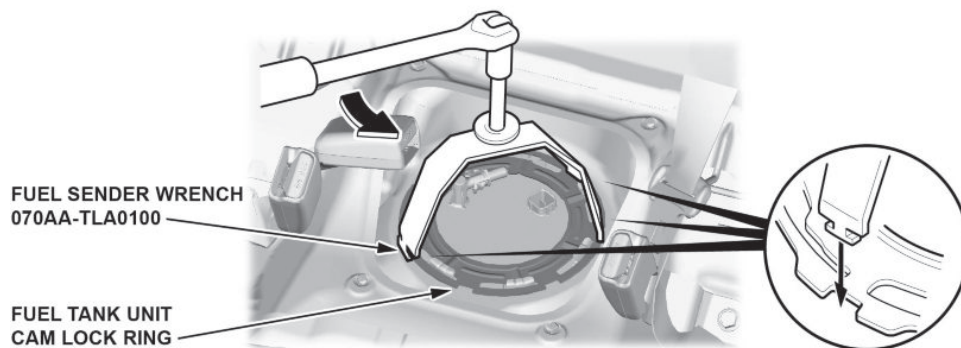

18. Turn the fuel tank unit cam lock ring counterclockwise to unlock it.

NOTE:

- After unlocking the fuel tank unit cam lock ring, clean the top of the fuel pump flange and adjacent areas to make sure it's free of dirt, dust, and debris.
- Make sure to keep the fuel sender wrench from floating.

19. Remove the fuel tank unit.

NOTICE

Do not to bend or twist the fuel level sensor arm excessively. This may damage the fuel level sensor or cause it to send inaccurate readings.

NOTE:

- After removing the fuel pump unit, clean the fuel tank around the fuel pump opening.
- After removing the fuel pump O-ring, clean the fuel tank around the O-ring opening and make sure it's free of dirt, dust, and debris.

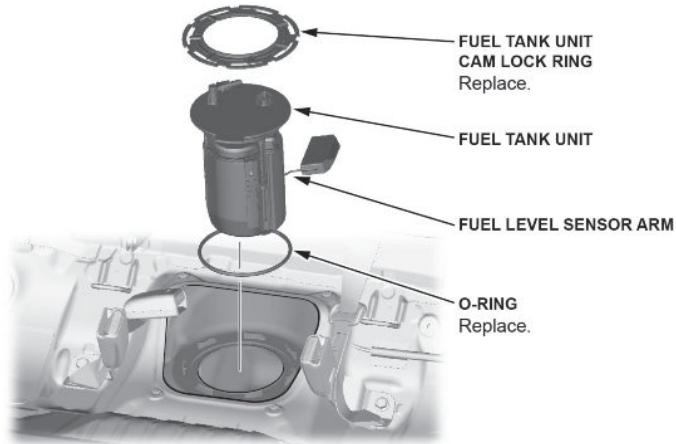

20. Prepare the fuel pump and parts to be replaced.

NOTE: Take a photo of the fuel tube and wire harness, and note their routing for assembly. There are various types of routing.

21. Spread the wire harness clamps, and remove the wire harness. Make sure not to damage the wire harness.

NOTICE

Do not spread the clamps too wide. Spreading them too wide may damage them.

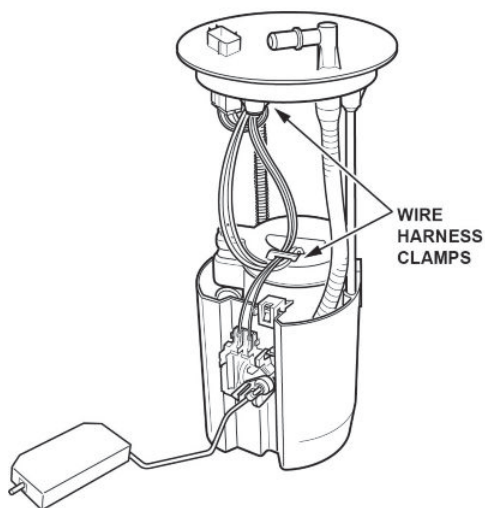

22. Press the tab on the fuel level sensor to release the lock. Then, push up on the fuel level sensor.

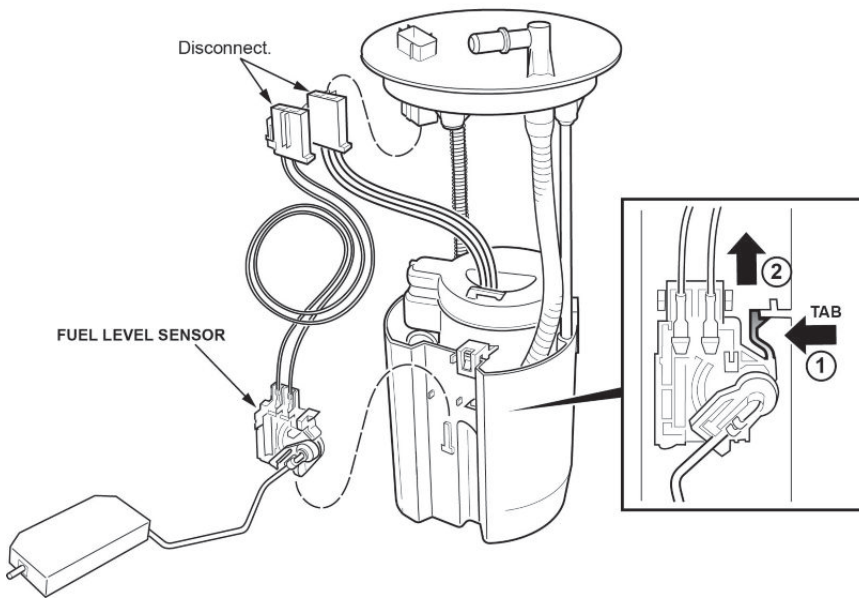

23. Disconnect the fuel level sensor harness and remove the fuel level sensor from the fuel tank unit.

24. Remove the E-ring, and discard it.

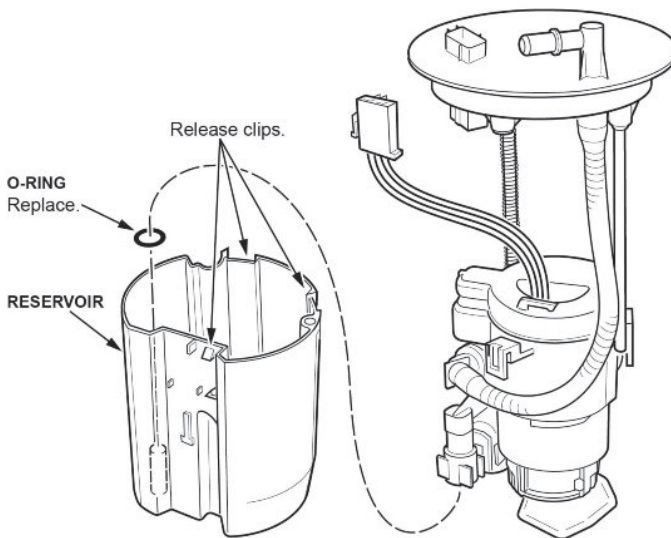

25. Remove the fuel filter assembly from the reservoir by releasing the three clips.

NOTICE

Do not spread the clips too wide. Spreading them too wide may damage them.

NOTE: The spring may slide off the sliding shaft. Retain this spring. It will be used during assembly.

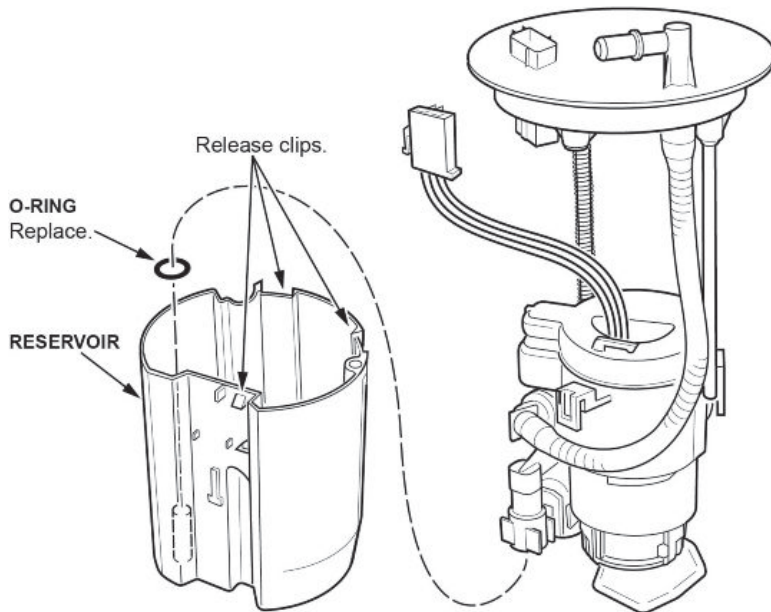

26. Release the three clips at the base of the fuel pump assembly and remove it from the fuel filter.

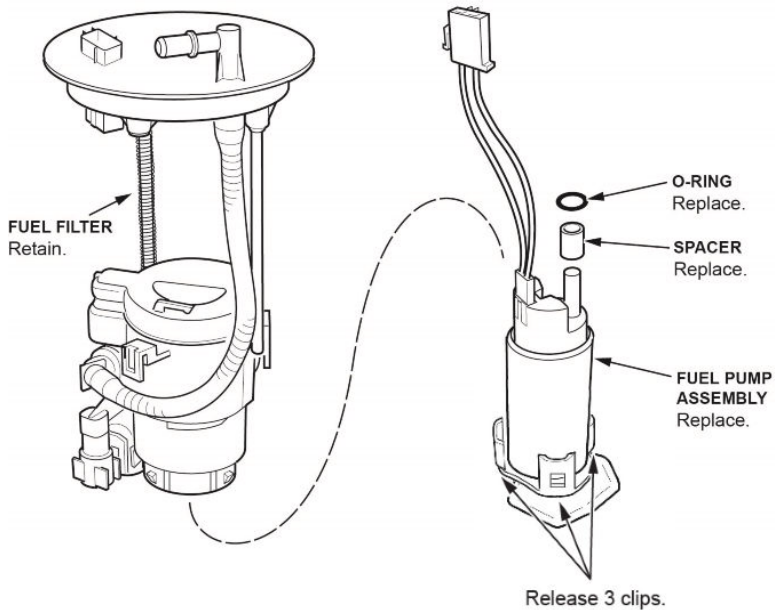

27. Pull the fuel pump assembly out of the fuel filter.

NOTE: If the O-ring remains on the fuel filter, use a flat-tip screwdriver wrapped in protective tape to remove it. Make sure not to damage the O-ring seat section.

28. Install the new spacer on the new fuel pump motor.

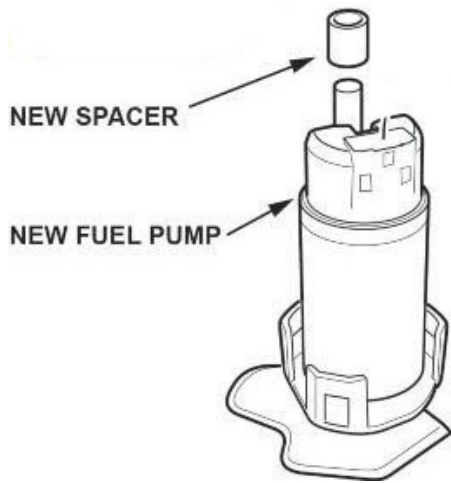

29. Install the new O-ring, then lubricate the outside edge of it, using only clean engine oil.

NOTE: Do not pinch the O-ring during installation.

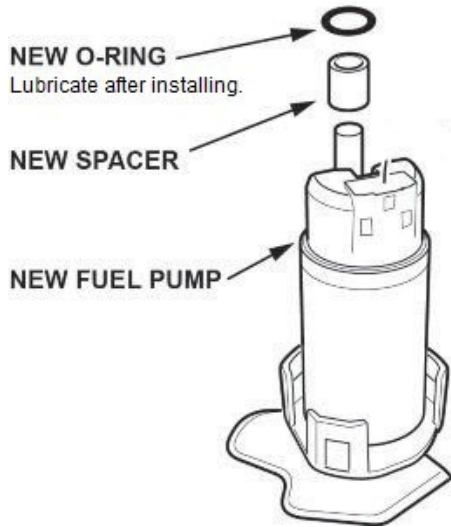

30. Install the new harness and make sure the connection is secure and the connectors are firmly locked into place.

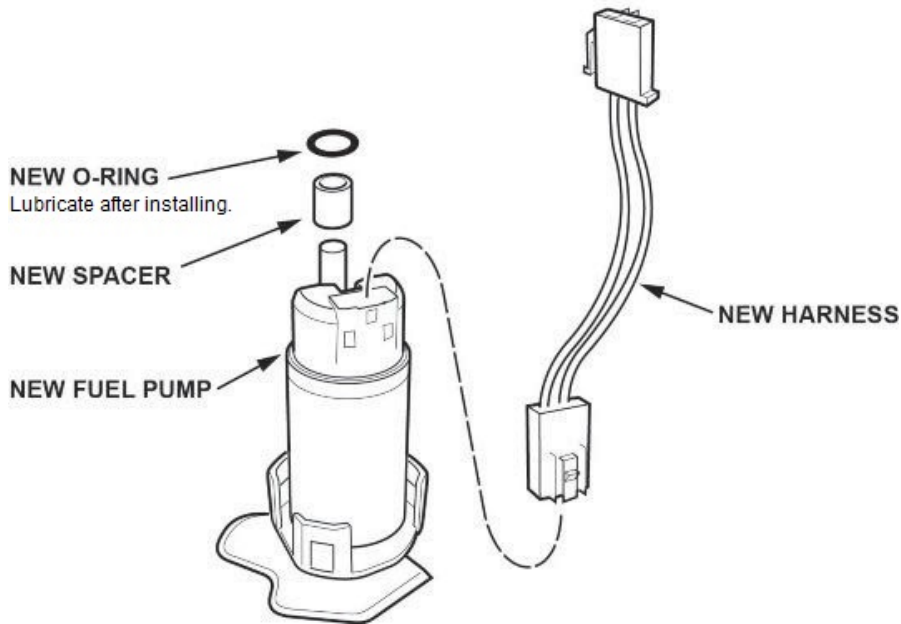

31. Place the fuel pump on a bench, then install the filter to the fuel pump.

NOTE: If the fuel pump does not engage into the fuel filter in one step, confirm that the O-ring is still set before repeating fuel pump installation.

32. Install the fuel filter assembly to the reservoir.

NOTE:

- Coat the O-ring with clean engine oil; do not use any other oil or fluid.
- Do not pinch the O-ring during installation.
- Insert the spring into the sliding shaft, and make sure it is lined up when installing the fuel filter.
- Make sure to route the fuel tube **exactly** as shown in the photo taken before disassembly.
- Make sure the three clips are fully engaged.

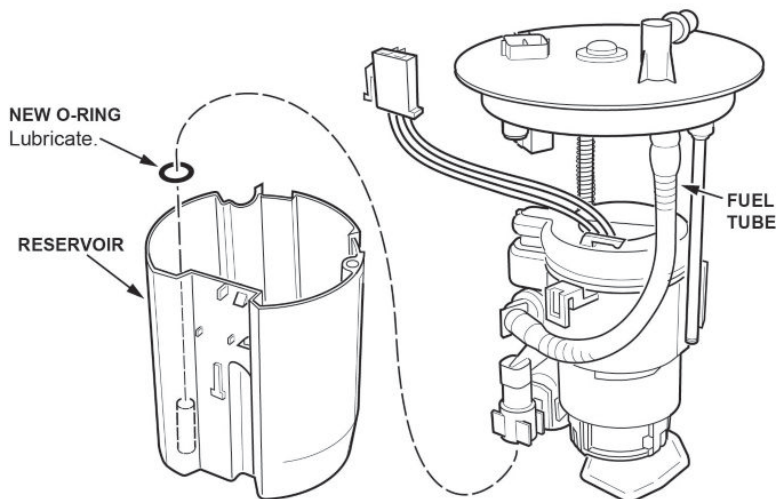

33. Install the new E-ring.

NOTE: After installation, make sure the E-ring can be rotated with your finger. If it cannot be rotated, the E-ring may not be fully seated or may be incorrectly installed.

34. Install the fuel level sensor to the reservoir. Make sure the lock is engaged and the connection is secure.

NOTICE

Do not to bend or twist the fuel level sensor arm excessively. This may damage the fuel level sensor or cause it to send inaccurate readings.

35. Install the wiring harness to the clamps.

NOTICE

Do not spread the clamps too wide. Spreading them too wide may damage them.

NOTE:

- Clip in the smaller harness wires followed by the larger wires.
- Make sure not to damage the wire harness.
- Make sure to route the wire harness **exactly** as shown in the photo taken before disassembly.

HARNES ROUTING:

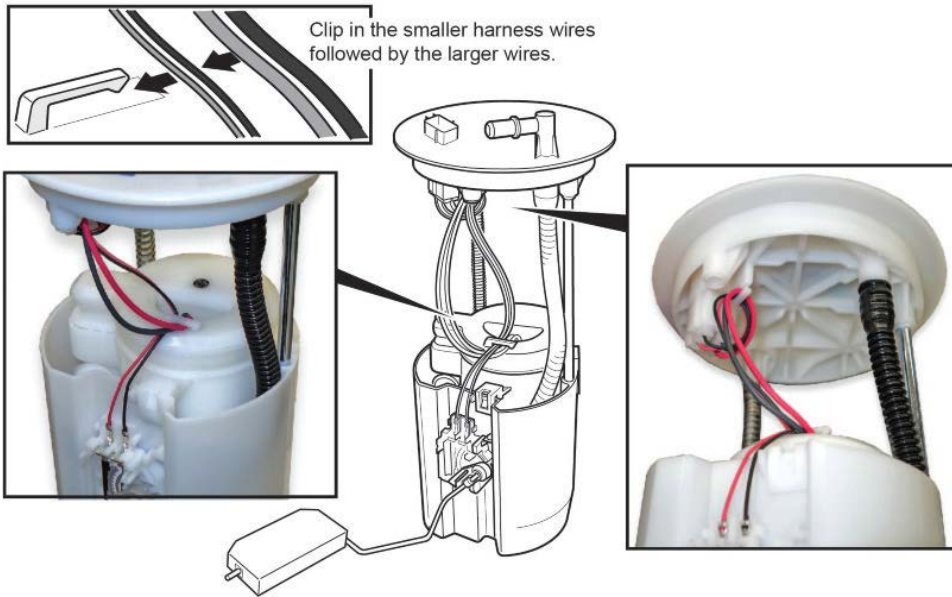

36. While compressing the fuel tank unit, make sure the movement is smooth and the fuel tube and wiring harness do not stretch, pinch, or bind.

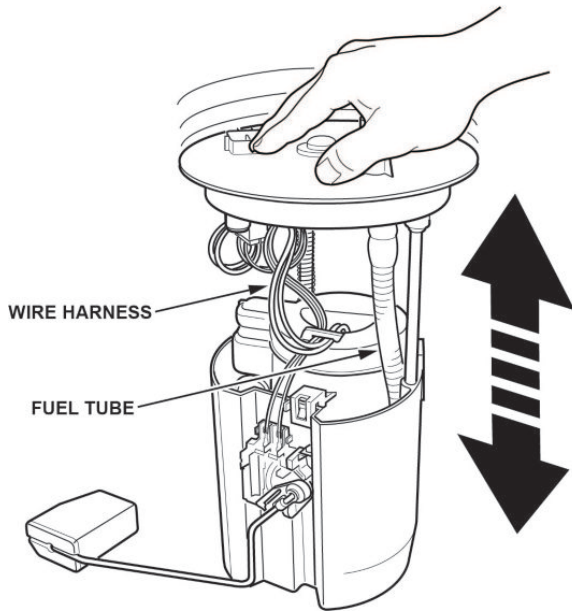

37. Install the fuel tank unit into the fuel tank with a new O-ring.

NOTICE

Do not to bend or twist the fuel level sensor arm excessively. This may damage the fuel level sensor or cause it to send inaccurate readings.

NOTE:

- Be careful not to damage the O-ring.
- Do not coat the O-ring with any oil.

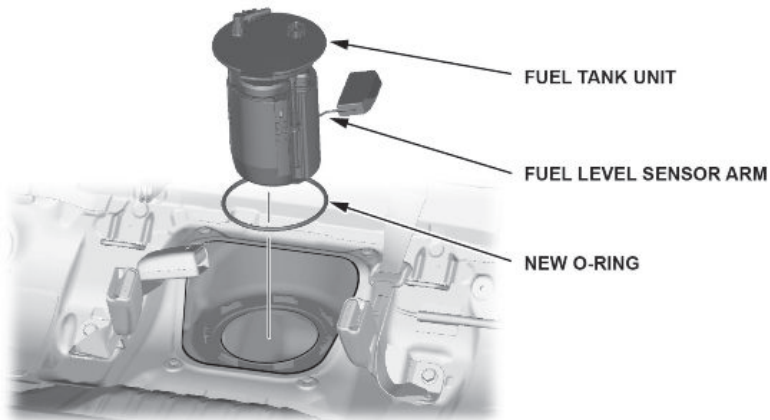

38. Line up the tab of the fuel tank unit as shown, and partially install the new fuel tank unit cam lock ring.

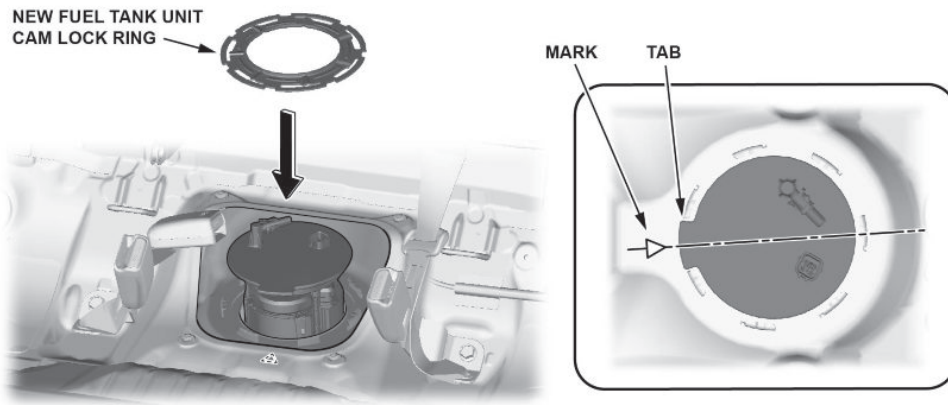

39. Tighten the fuel tank unit cam lock ring.

NOTICE

If the cam lock ring is not properly installed, the fuel tank can be damaged and will require replacement.

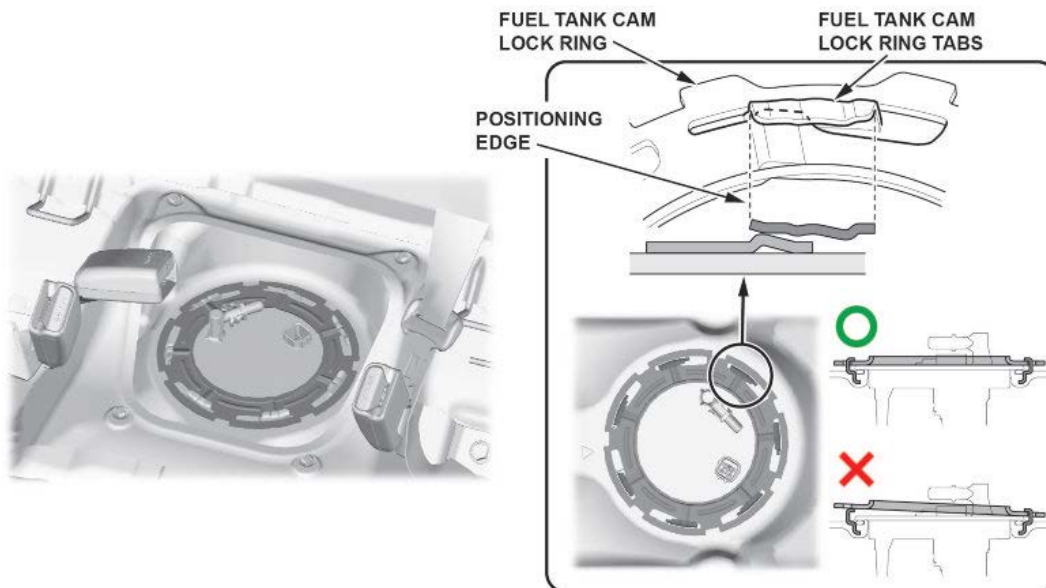

40. Turn the fuel tank unit cam lock ring by hand, and slide the fuel tank unit cam lock tabs to the positioning edge as shown.

NOTE: Make sure the fuel cam lock ring is not floating.

41. Turn the fuel tank unit cam lock ring clockwise using the fuel sender wrench.

NOTE:

- Keep the fuel sender wrench from floating.
- Securely set the positioning edge of the fuel tank to the tabs on the cam lock ring as shown.

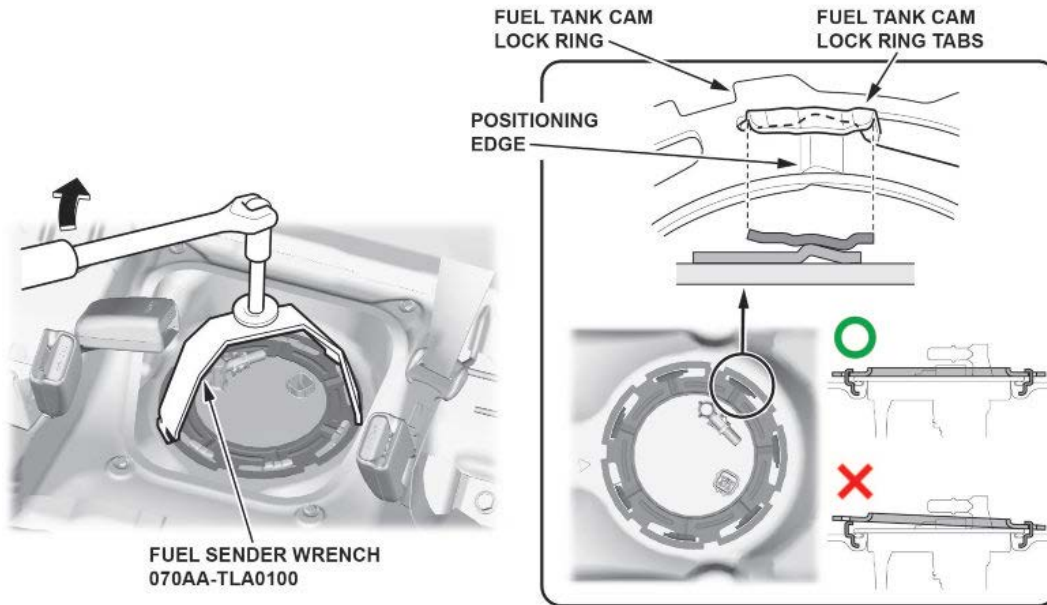

42. Remove the quick-connect fitting retainer from the fuel tank unit, then install a new retainer onto the quick-connect fitting.

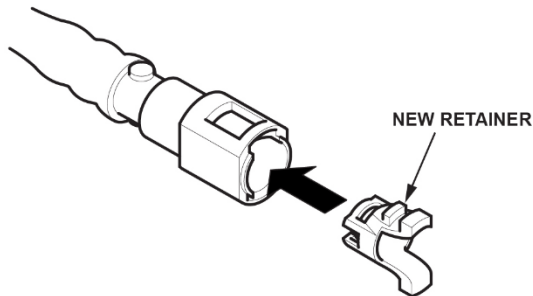

43. Connect the fuel line quick-connect fitting.

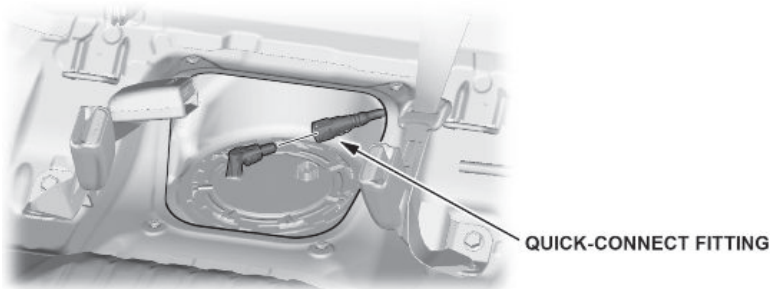

44. Connect the fuel tank unit connector.

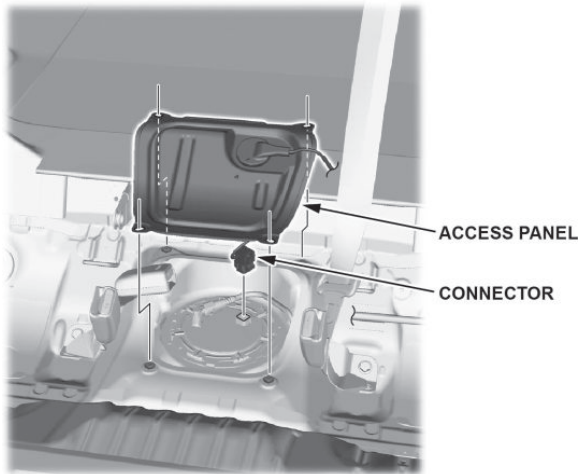

45. Connect the 12-volt negative battery terminal.

46. Turn the vehicle to ON, but do not turn the engine on. After the fuel pump runs for about **2 seconds**, the fuel line will be pressurized. Repeat this two or three times, then make sure there is no fuel leakage.

47. Install the fuel tank unit access panel.

48. Install the remaining parts in the reverse order of removal.

49. Clear all DTCs using an i-HDS.

50. Do the VSA Sensor Neutral Position Memorization procedure.

51. *California residents only:* Fill out a Vehicle Emissions Recall – Proof of Correction certificate, and use **YAH** as the recall number. Have the service advisor give the certificate to your customer, and advise him or her to keep it as proof that the recall was completed. Your customer will need to submit this certificate to the DMV only if the DMV requests it. If you need more certificates, use reorder number **Y0657**.

Vehicle Emission Recall - Proof of Correction				
License Number	Make	Year Model	Body Type	Vehicle Identification Number
Manufacturer _____			Recall Number YAH	
The above described vehicle has been repaired, modified and/or equipped with new emission control devices to meet applicable California Emission Control Laws.				
Dealer's Name		Address, City, State and Zip		
Date	Dealership's Authorized Signature			
	X			
Return this certificate to DMV only when required - otherwise retain for your records.				

Y0657 ACL 24832 (0212)

END