

## Safety Recall: 2019 Odyssey Fuel Pump Motor

### AFFECTED VEHICLES

Year	Model	Trim Level	VIN Range
2019	Odyssey	ALL	Check the iN VIN status for eligibility.

### BACKGROUND

Due to swelling of the fuel pump motor impeller, the fuel pump may seize and stop working. If this occurs, the check engine light may be displayed with DTC P0087 (Fuel Rail Pressure Too Low) stored, the engine may not start, or the engine could stall while driving, increasing the risk of a crash.

### CUSTOMER NOTIFICATION

Owners of affected vehicles will be sent a notification of this campaign.

Do an iN VIN status inquiry to make sure the vehicle is shown as eligible.

Some vehicles affected by this campaign may be in your new or used vehicle inventory.

Failure to repair a vehicle subject to a recall or campaign may subject your dealership to claims or lawsuits from the customer or anyone else harmed as a result of such failure. To see if a vehicle in inventory is affected by this safety recall, do a VIN status inquiry before selling it.

### CORRECTIVE ACTION

Replace the fuel pump motor.

NOTE: If the vehicle has any of the symptoms listed in BACKGROUND, you must apply this bulletin before attempting any other repairs. If the symptoms remain after the recall repair is complete, only attempt further repairs (such as replacing the high pressure fuel pump) after authorized troubleshooting.

### PARTS INFORMATION

NOTE: Due to limited supply, this is a controlled part and will require a valid VIN when ordering.

Part Name	Part Number	Quantity
Fuel Pump Motor Kit	06170-THR-306	1

**For dealers experiencing a strong fuel smell from storing a fuel pump motor replaced under this service bulletin,** the fuel pump motor may be disposed of immediately in accordance with local regulations. This only applies to the fuel pump motor replaced under this service bulletin. The published retention policy remains in effect for all other parts.

If you have any questions about this exception or other parts retention issues, contact the WPI Administrative Office at **937-642-2737**.

**CUSTOMER INFORMATION:** The information in this bulletin is intended for use only by skilled technicians who have the proper tools, equipment, and training to correctly and safely maintain your vehicle. These procedures should not be attempted by "do-it-yourselfers," and you should not assume this bulletin applies to your vehicle, or that your vehicle has the condition described. To determine whether this information applies, contact an authorized Honda automobile dealer.

## TOOL INFORMATION

Tool Name	Part Number	Quantity
Fuel Sender Wrench	070AA-TLA0100	1

## WARRANTY CLAIM INFORMATION

Operation Number	Description	Flat Rate Time	Defect Code	Symptom Code	Template ID	Failed Part Number
3101HK	Replace the fuel pump motor.	1.2 hr	6FE00	MAD00	A21026A	17045-THR-A03

Skill Level: Repair Technician

## REPAIR PROCEDURE

### ⚠ WARNING

Fuel pump motor removal exposes fuel, which can ignite, causing a fire or explosion.

This can cause serious injury or death.

Always work in a well-ventilated area and keep sparks or open flames away.

1. Remove the emergency fuel fill funnel.

NOTE: The emergency fuel fill funnel is located in the right rear side trim panel.

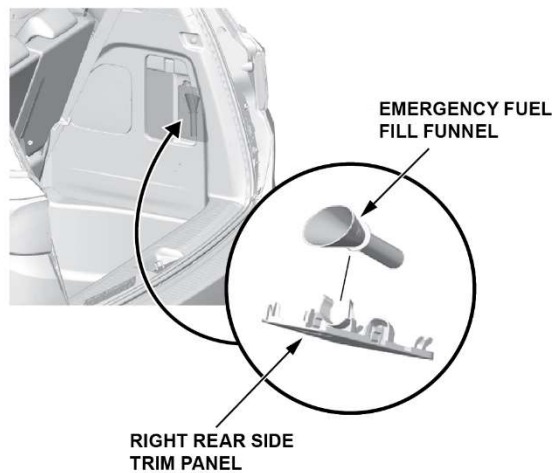

2. Insert the emergency fuel fill funnel into the fuel filler neck to relieve the pressure in the fuel tank.



3. Remove the left side second row seat head restraint.
4. Slide the seat to its rearmost position.
5. Pull the seat-back angle adjustment lever, then fold the seat-back down.

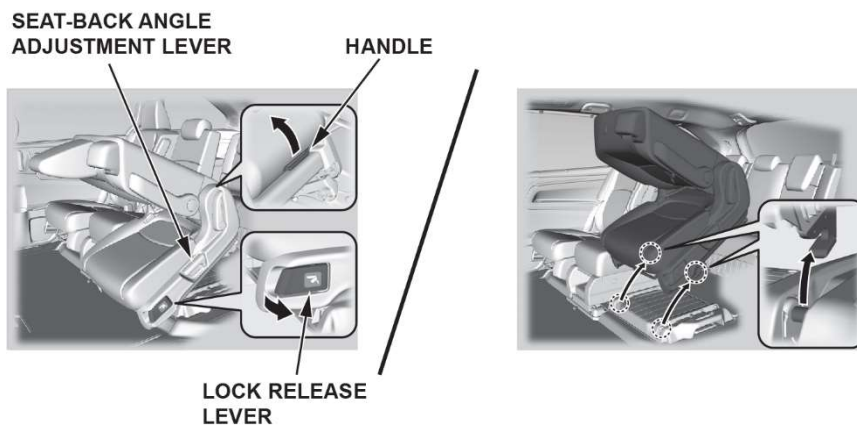

6. Pull the lock release lever, tilt the seat-back forward and the lift the rear of the seat.  
NOTE: To lift the seat, grab the handle under the rear of the seat.

7. *With second row center seat:* Remove the second row center seat.

- Insert a key into the slot on the side of the center buckle.

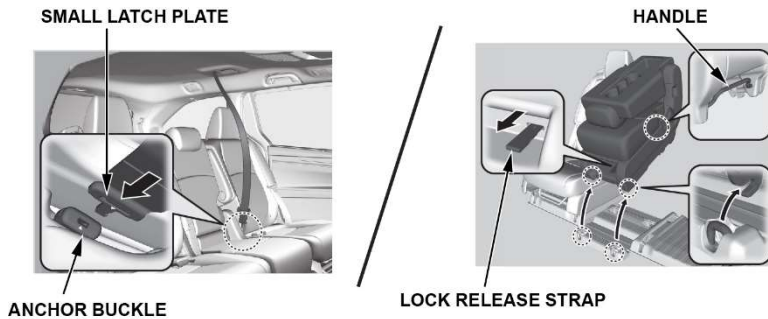

- Retract the center seat belt into the holder in the ceiling.
- Fold the seat-back down.
- Pull the lock release strap under the front of the seat cushion, and lift the rear of the seat using the handle under the rear of the seat cushion.
- Pivot the seat upward and forward to unhook the front of the seat from the floor.

8. Remove the left upper carrier cover.

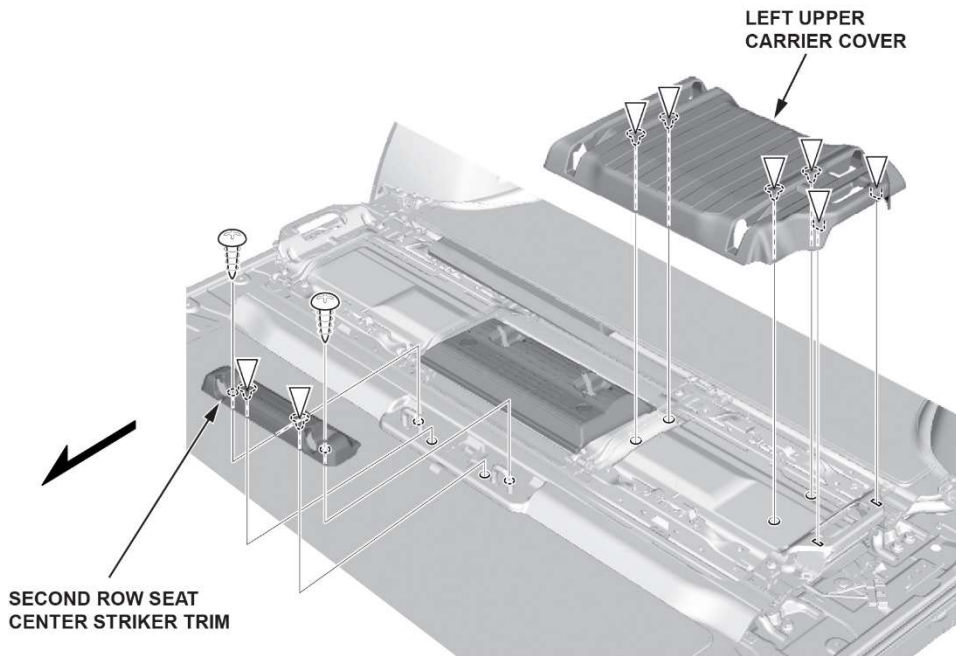

9. *With second row center seat:* Remove the second row seat striker trim.

10. Relieve the fuel pressure.

*With an i-HDS:*

- Connect an i-HDS to the DLC located under the driver's side of the dashboard.



- Turn the vehicle to ON.
- Select the **PGM-FI** system on the i-HDS.
- Select **FUEL PUMP OFF** from the **Function Test** menu.
- Start the engine, and let it idle until it stalls.
- Turn the ignition to OFF.

*Without an i-HDS:*

- Remove the fuel tank unit access panel.

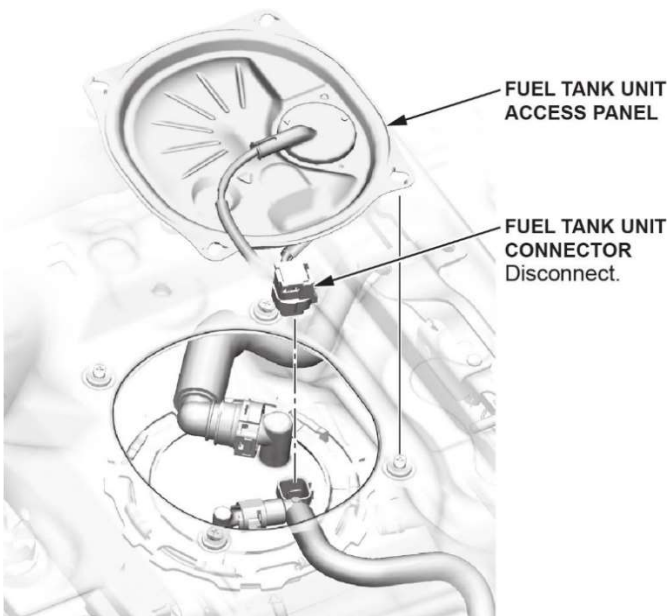

- Disconnect the fuel tank unit connector.
- Start the engine, and let it idle until it stalls.
- Turn the ignition to OFF.

**NOTE:**

- Do not allow the engine to idle above 1,000 rpm or the PCM will continue to operate the fuel pump.
- A pending or confirmed DTC may be set during this procedure. After the repair is complete, check for DTCs, and clear them as needed.

11. Remove the front bulkhead cover.

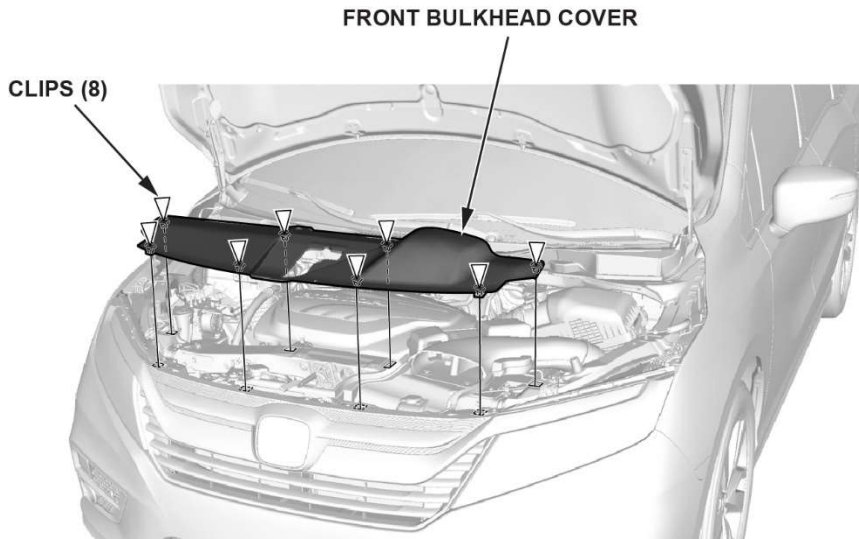

12. Remove the air intake duct.

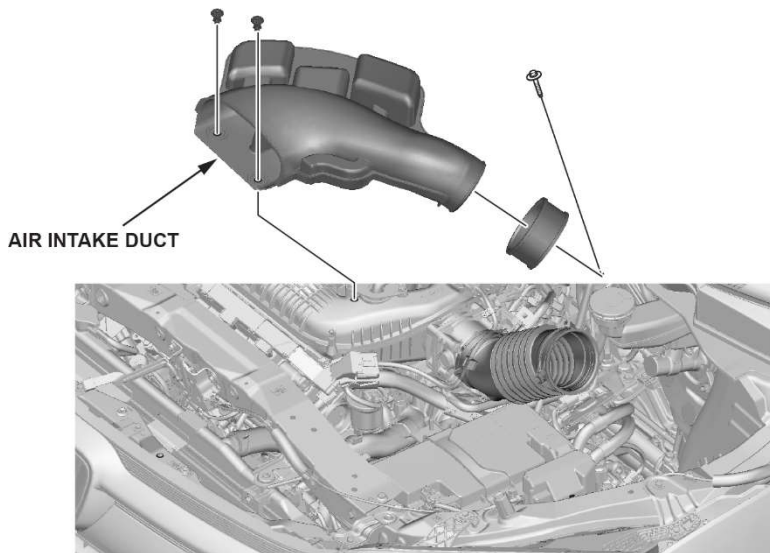

13. Open the battery terminal cover.

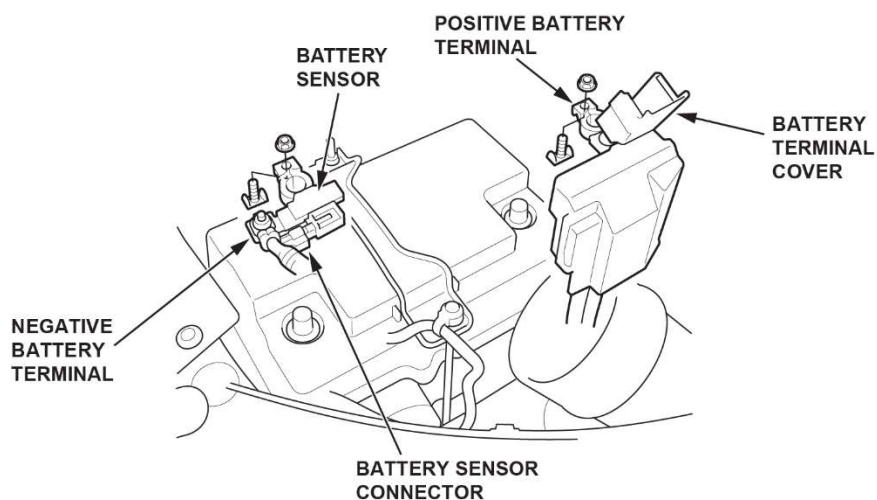

14. Disconnect both 12-volt battery terminals.

**NOTICE**

To protect the terminal connector from damage, do not hold it when removing the negative terminal.

**NOTE:**

- Always disconnect the negative terminal first.
- Do not disconnect the 12-volt battery sensor from the cable.

15. Place a rag or shop towel over the quick-connect fitting, and disconnect it.

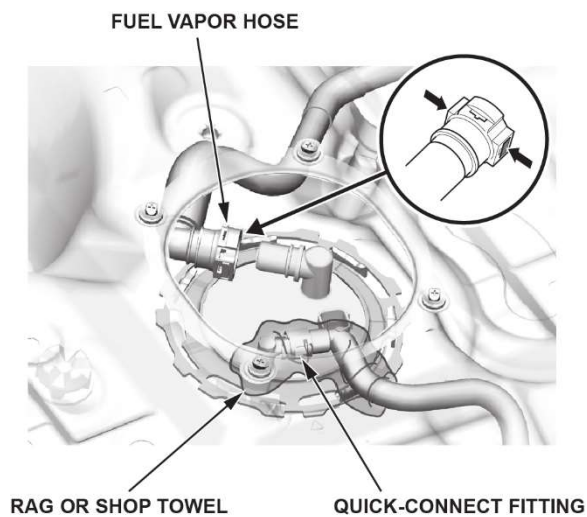

16. Disconnect the fuel vapor hose.



17. Set the fuel sender wrench (070AA-TLA0100) on the cam lock ring as shown.

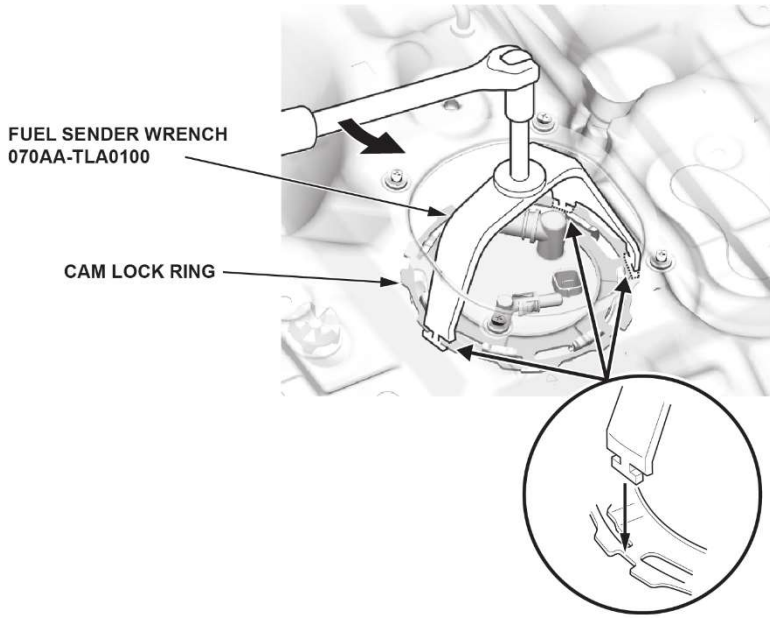

18. Turn the fuel tank unit cam lock ring counterclockwise to unlock it.

NOTE: Keep the fuel sender wrench from floating.

19. Remove the fuel tank unit.

**NOTICE**

Do not to bend or twist the fuel level sensor arm excessively. This may damage the fuel level sensor or cause it to send inaccurate readings.

20. Hook the lanyard of the ORVR service plug as shown. Set the ORVR service plug near the fuel tank unit opening.

NOTE: Avoid damaging any part of the ORVR service plug's surface. Damage to the ORVR service plug may cause fuel leaks into the inner fuel vent tube. Use the provided protective cap when the ORVR service plug is not in use. If there is damage, discard the ORVR service plug and order a new one.

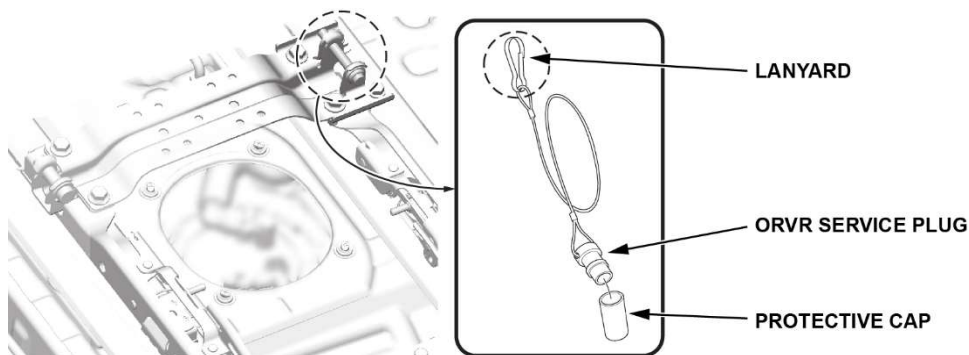



21. Disconnect the inner fuel vent tube from the fuel tank unit, and hold it.

**NOTICE**

Do not allow the inner fuel vent tube to fall inside the fuel tank before installing the ORVR service plug to it. If fuel enters the inner fuel vent tube, a DTC will set and the inner fuel vent tube will need to be replaced.

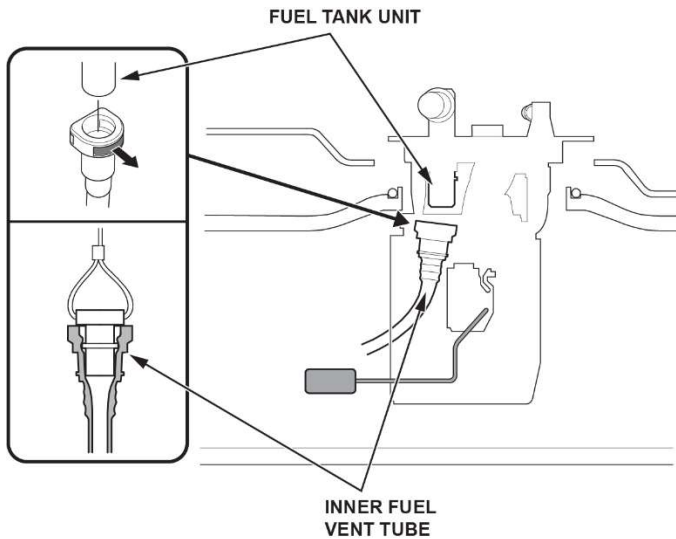

22. Install the ORVR service plug to the inner fuel vent tube. Make sure the ORVR service plug is fully seated by holding the inner fuel vent tube and gently pulling on the plug's lanyard.

NOTE: The ORVR service plug should not come off.

23. Carefully lower the inner fuel vent tube into the fuel tank, making sure the lanyard of the ORVR service plug is free and away from the fuel tank unit.

NOTE: It is OK for the plugged tube to be submerged in the fuel.

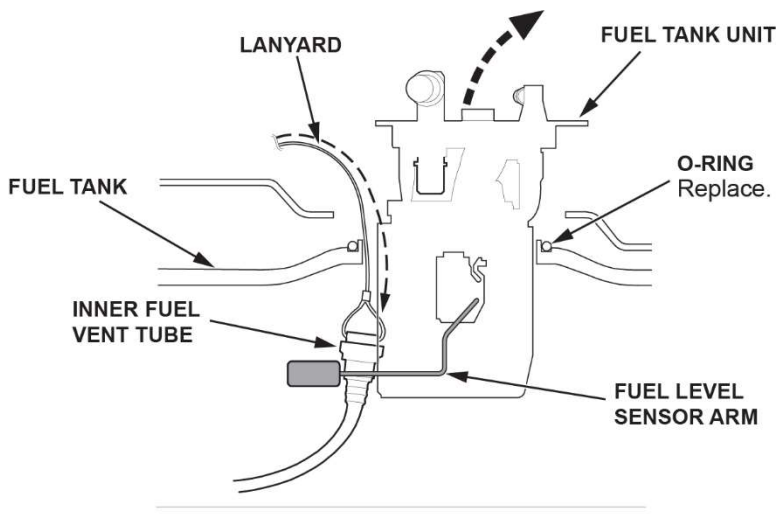

24. Remove the fuel tank unit with the O-ring.

**NOTICE**

Do not to bend or twist the fuel level sensor arm excessively. This may damage the fuel level sensor or cause it to send inaccurate readings.

25. Prepare the fuel tank unit and parts to be replaced.

NOTE: Take a photo of the fuel tube and wire harness, and note their routing for assembly. There are various types of routing.

26. Spread the wire harness clamps, and remove the wire harness. Make sure not to damage the wire harness.

**NOTICE**

Do not spread the clamps too wide. Spreading them too wide may damage them.

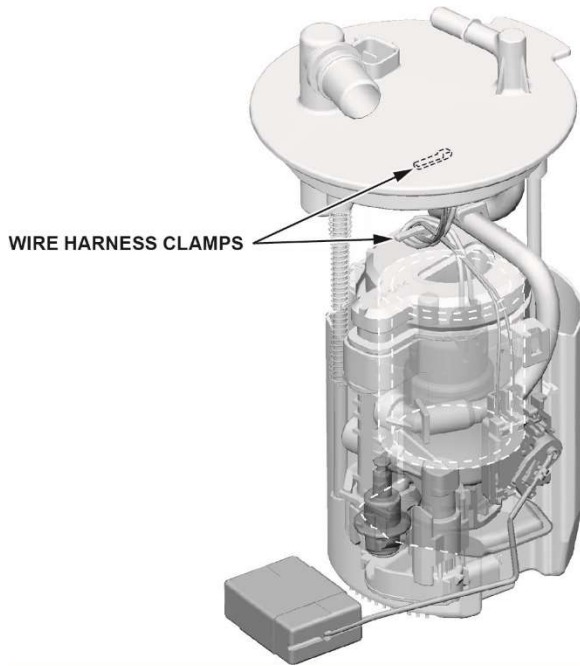

27. Press the tab on the fuel level sensor to release the lock. Then, push up on the fuel level sensor.

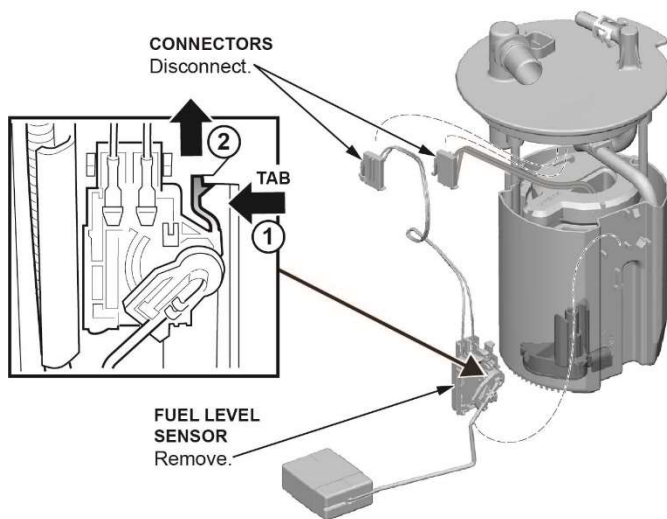

28. Disconnect the fuel level sensor harness, and remove the fuel level sensor from the fuel tank unit.

29. Remove the E-ring, and discard it.

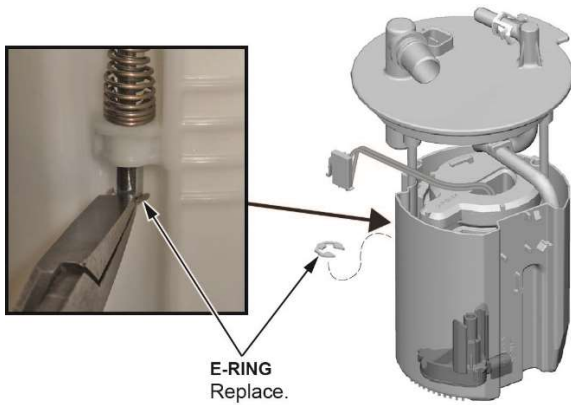

30. Remove the fuel filter assembly from the reservoir by releasing the three clips.

**NOTICE**

Do not spread the clips too wide. Spreading them too wide may damage them.

NOTE: The spring may slide off the sliding shaft. Retain this spring. It will be used during assembly.

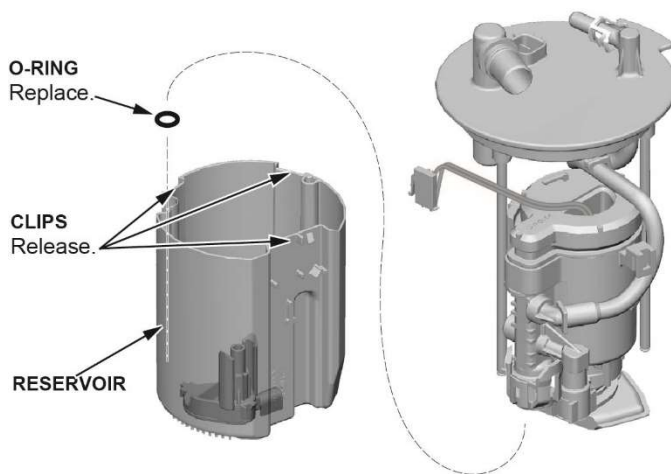

31. Release the three clips at the base of the fuel pump assembly and remove it from the fuel filter.

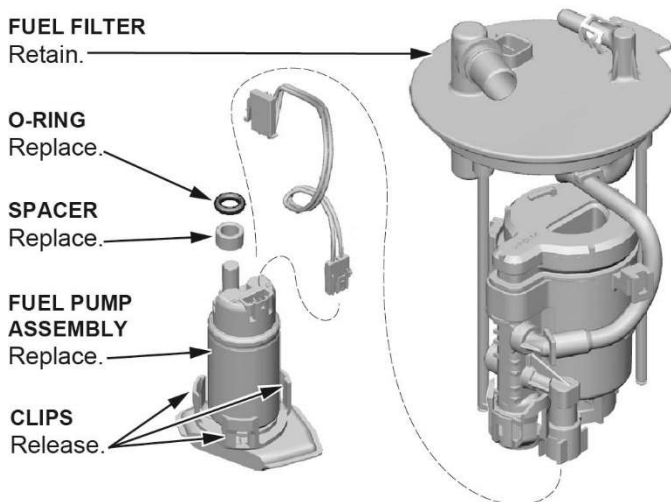

32. Pull the fuel pump assembly out of the fuel filter.

NOTE: If the O-ring remains on the fuel filter, use a flat-tip screwdriver wrapped in protective tape to remove it. Make sure not to damage the O-ring seat section.

33. Install the new spacer, O-ring, and wire harness to the new fuel pump.

NOTE:

- **The O-ring must be installed on the pump as shown, not on the fuel filter side.**
- Coat the O-ring with clean engine oil; do not use any other oil or fluid.
- Do not pinch the O-ring during installation.
- When connecting the wire harness, make sure the connection is secure and the connectors are firmly locked into place.
- Use all of the new parts supplied in the replacement kit.

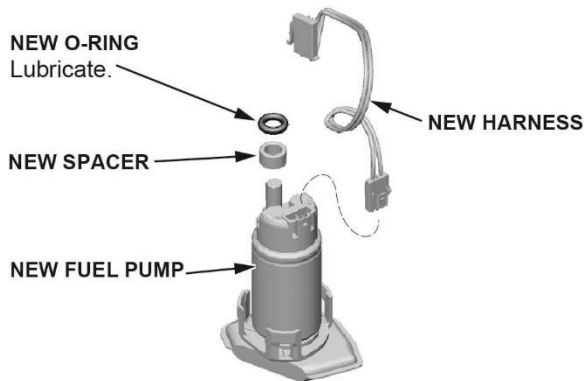

34. Place the fuel pump on a bench, then install the filter to the fuel pump.

35. Install the fuel filter assembly to the reservoir.

NOTE:

- Coat the O-ring with clean engine oil; do not use any other oil or fluid.
- Do not pinch the O-ring during installation.
- Insert the spring into the sliding shaft, and make sure it is lined up when installing the fuel filter.
- Make sure to route the fuel tube **exactly** as shown in the photo taken before disassembly.
- Make sure the three clips are fully engaged.

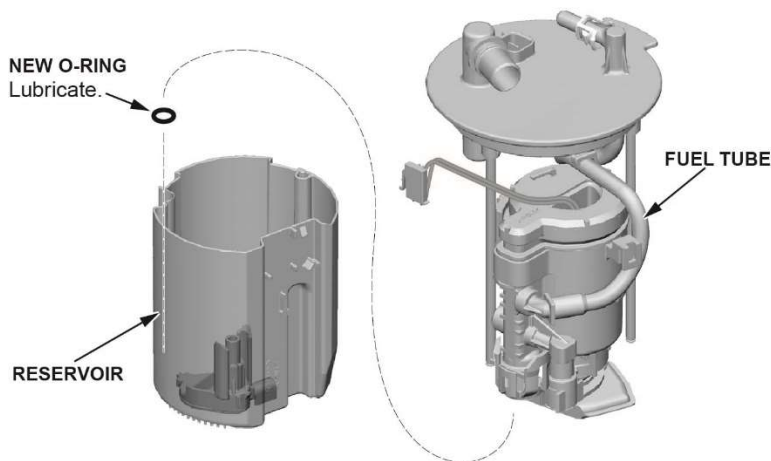

36. Install the new E-ring.

NOTE: After installation, make sure the E-ring can be rotated with your finger. If it cannot be rotated, the E-ring may not be fully seated or may be incorrectly installed.

37. Install the fuel level sensor to the reservoir. Make sure the lock is engaged and the connection is secure.

**NOTICE**

Do not to bend or twist the fuel level sensor arm excessively. This may damage the fuel level sensor or cause it to send inaccurate readings.

38. Install the wiring harness to the clamps.

**NOTICE**

Do not spread the clamps too wide. Spreading them too wide may damage them.

**NOTE:**

- Clip in the smaller harness wires followed by the larger wires.
- Make sure not to damage the wire harness.
- Make sure to route the wire harness **exactly** as shown in the photo taken before disassembly.

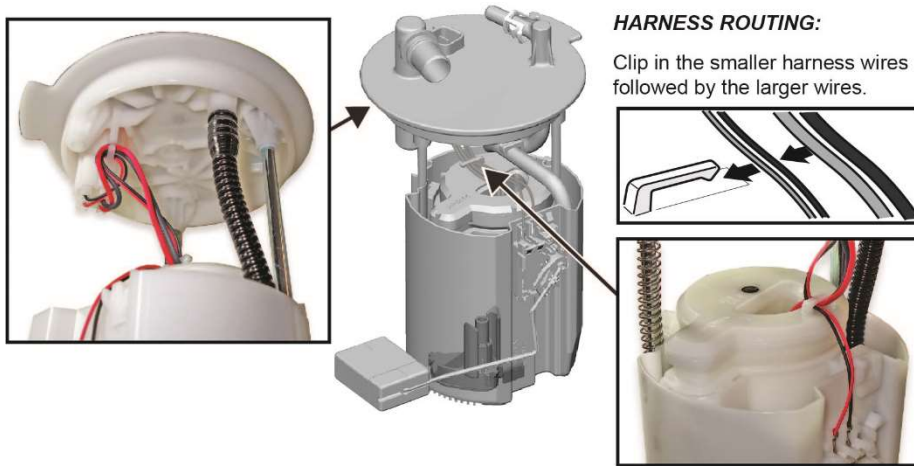

39. While compressing the fuel tank unit, make sure the movement is smooth and the fuel tube and wiring harness do not stretch, pinch, or bind.

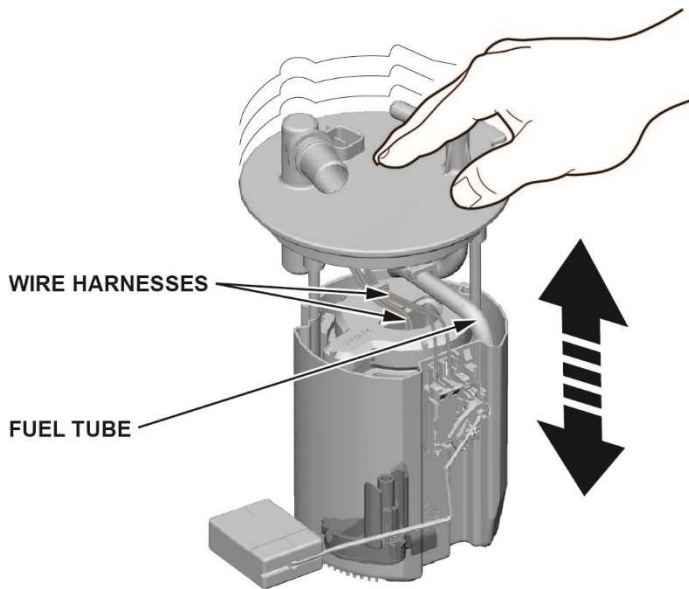

40. Install the fuel tank unit into the fuel tank with a new O-ring.

NOTE:

- Be careful not to damage the O-ring.
- Do not coat the O-ring with any oil.

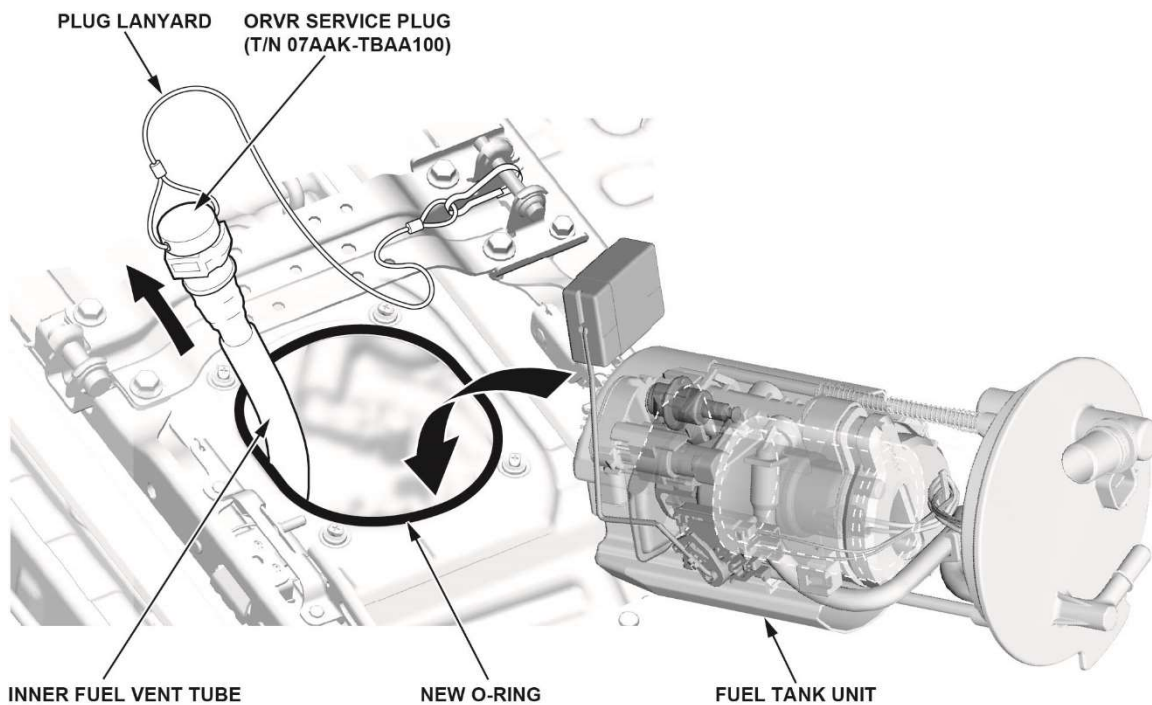

41. Grab the plug lanyard, and pull the inner fuel vent tube up until it is close to the fuel tank opening. Hold the tube while installing the fuel tank unit.

42. Move the fuel tank unit aside, and remove the ORVR service plug from the inner fuel vent tube.

**NOTICE**

Do not allow the inner fuel vent tube to fall inside the fuel tank before installing the ORVR service plug to it. If fuel enters the inner fuel vent tube, a DTC will set and the inner fuel vent tube will need to be replaced.

43. Move the ORVR service plug away from the tank opening, and connect the inner fuel vent tube to the fuel tank unit.

**NOTICE**

Do not to bend or twist the fuel level sensor arm excessively. This may damage the fuel level sensor or cause it to send inaccurate readings.

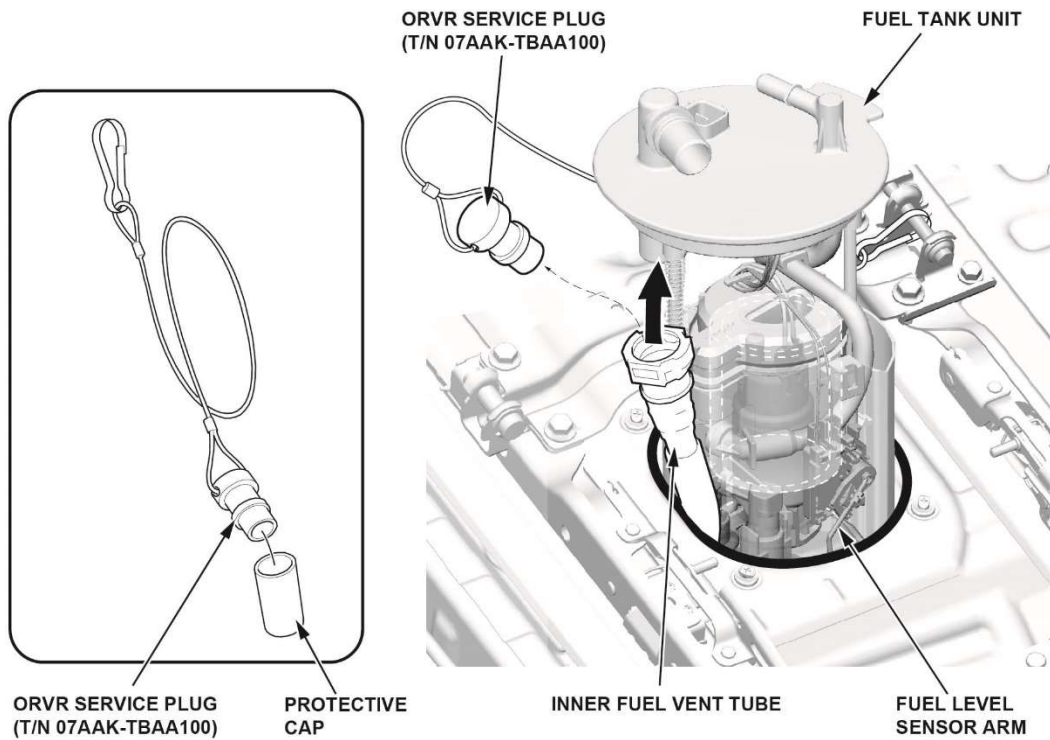

44. Remove the ORVR service plug from the child safety seat hook, and install the provided protective cap.



45. Line up the tab of the fuel tank unit as shown, and partially install the new fuel tank unit cam lock ring with a new O-ring.

**NOTICE**

Make sure the fuel cam lock ring is not floating. If the cam lock ring is not properly installed, the fuel tank can be damaged and will require replacement.

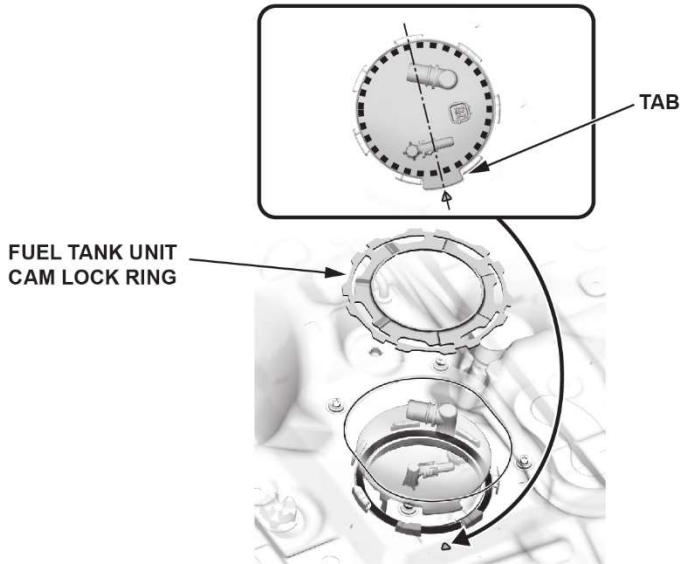

46. Rotate the fuel tank unit cam lock ring (A) and slide the fuel tank unit cam lock tabs (B) into the positioning edge (C) slightly as shown by hand.

NOTE: Confirm the fuel cam lock ring is not floating.

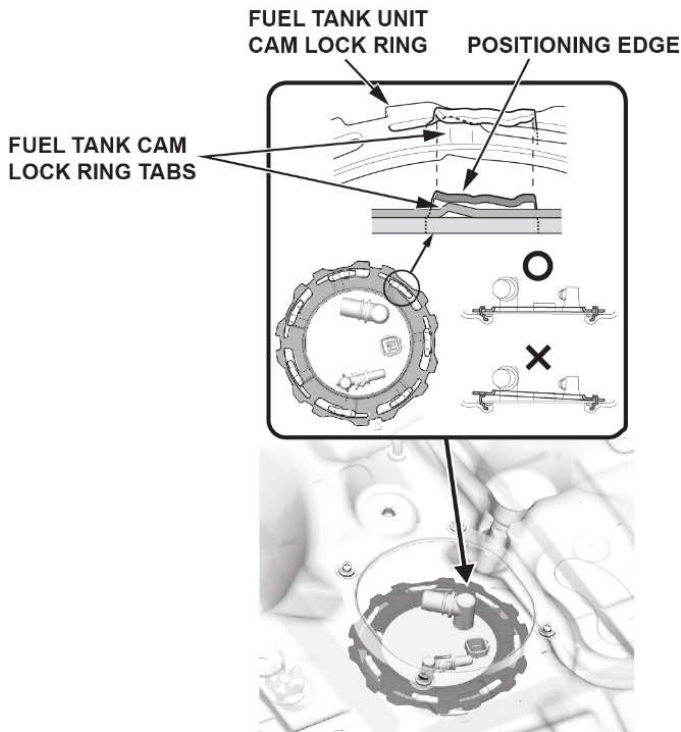

47. Tighten the fuel tank unit cam lock ring by turning clockwise using the fuel sender wrench.

NOTE:

- Keep the fuel sender wrench from floating.
- Securely set the positioning edge of the fuel tank to the tabs on the cam lock ring as shown.

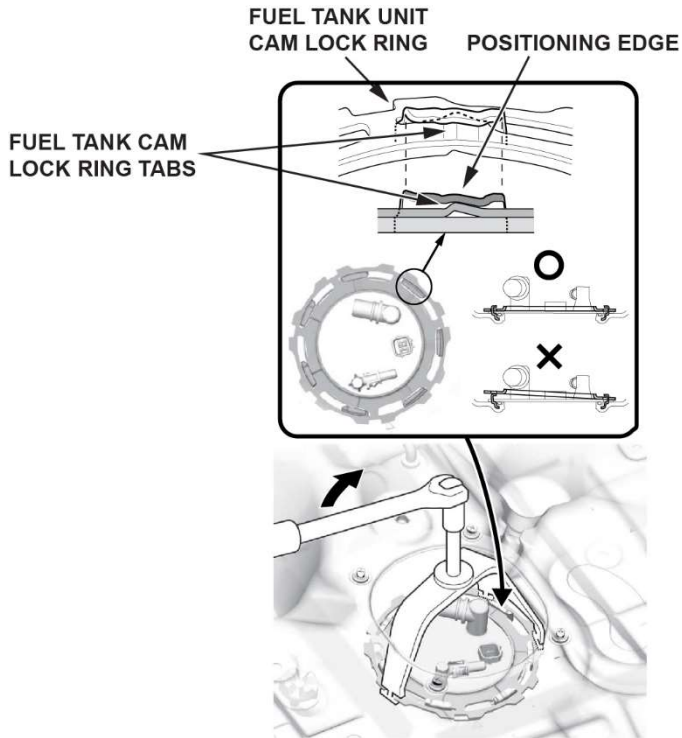

48. Remove the quick-connect fitting retainer from the fuel tank unit, then install a new retainer onto the quick-connect fitting.

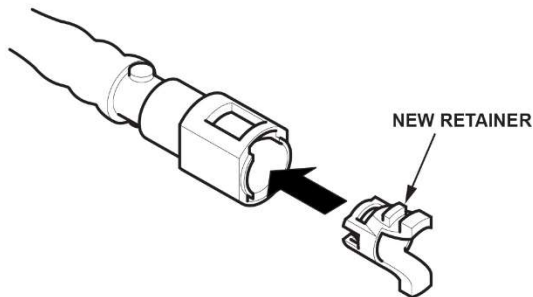

49. Connect the fuel vapor hose, the fuel line quick-connect fitting, and fuel tank unit connector.

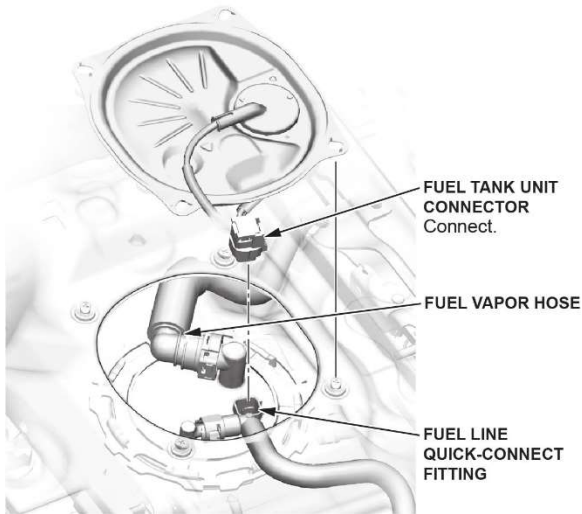

50. Connect the 12-volt battery terminals.

51. Turn the ignition to ON, but do not turn the engine on. After the fuel pump runs for about **2 seconds**, the fuel line will be pressurized. Repeat this two or three times, then make sure there is no fuel leakage.

52. Install the fuel tank unit access panel.

53. Install the remaining parts in the reverse order of removal.

54. Clear all DTCs using an i-HDS.

55. *California residents only:* Fill out a Vehicle Emissions Recall – Proof of Correction certificate, and use **MAD** as the recall number. Have the service advisor give the certificate to your customer, and advise him or her to keep it as proof that the recall was completed. Your customer will need to submit this certificate to the DMV only if the DMV requests it. If you need more certificates, use reorder number **Y0657**.

Vehicle Emission Recall - Proof of Correction				
License Number	Make	Year Model	Body Type	Vehicle Identification Number
Manufacturer _____			Recall Number <b>MAD</b>	
The above described vehicle has been repaired, modified and/or equipped with emission control devices to meet applicable California Emission Control Laws.				
Dealer's Name _____		Address, City, State and Zip _____		
Date _____	Dealership's Authorized Signature _____			
X				
Return this certificate to DMV only when required - otherwise retain for your records.				

Y0657 ACL 24832 (0212)

END