

Safety Recall

Code: 69BY



Subject
Release Date
Affected Vehicles

Passenger Occupant Detection System (PODS)

December 17, 2021

Country	Beginning Model Year	Ending Model Year	Vehicle	Vehicle Count
USA	2015	2019	A3 CABRIOLET	11,736
USA	2016	2018	A3 ETRON	9,573
USA	2015	2020	A3 SEDAN	113,164
USA	2017	2020	RS3 SEDAN	4,147
USA	2015	2020	S3 SEDAN	14,532
CAN	2016	2020	A3 CABRIOLET	1,742
CAN	2016	2018	A3 ETRON	1,384
CAN	2016	2020	A3 SEDAN	10,664
CAN	2018	2020	RS3 SEDAN	1,610
CAN	2016	2020	S3 SEDAN	2,804

Check Campaigns/Actions screen in Elsa on the day of repair to verify that a VIN qualifies for repair under this action. Elsa is the only valid campaign inquiry & verification source.

- ✓ Campaign status must show "open."
- ✓ If Elsa shows other open action(s), inform your customer so that the work can also be completed at the same time the vehicle is in the workshop for this campaign.

Problem Description

The passenger occupant detection system (PODS) may detect a malfunction and switch off the passenger airbag even though the seat may be occupied.

However, the airbag system and the warning strategy operate as designed. If the PODS malfunctions, a warning light in the instrument panel comes on together with an acoustic warning sound and an error message is displayed in the instrument cluster. The airbag indicator light shows "passenger airbag off". This error often occurs sporadically and for a limited amount of time. When the error (and consequently) the warnings disappear, the passenger airbag works again as intended without any action/interaction necessary by the customer. In the event of a crash necessitating passenger airbag activation, there would be an increased risk of injury to the occupant seated in the front passenger seat if the passenger airbag is switched off/not working.

Corrective Action

Replace passenger occupant detection system (PODS) sensor mat and update the PODS control module.

Precautions

Audi has advised that customers can continue driving these vehicles. Please ensure that everyone who uses your vehicle has read the owner's manual and is familiar with how the PODS works for the front passenger seat.

As designed, in case of a malfunction within the PODS, a warning light in the instrument panel will come on together with a warning sound and an error message will be displayed in the instrument cluster (the airbag indicator light shows "passenger airbag off"). If these warnings appear, Audi recommends that you stop using the front passenger seat and make arrangements to have the vehicle inspected/repared at an Audi dealership as soon as possible.

Code Visibility

On or about December 17, 2021, the campaign code will be applied to affected vehicles.

Owner Notification

Owner notification will take place in December 2021. Owner letter examples are included in this bulletin for your reference.

Additional Information

Please alert everyone in your dealership about this action, including Sales, Service, Parts and Accounting personnel. Contact Warranty if you have any questions.

IMPORTANT REMINDER ON VEHICLES AFFECTED BY SAFETY & COMPLIANCE RECALLS

New Vehicles in Dealer Inventory: It is a violation of federal law for a dealer to deliver a new motor vehicle or any new or used item of motor vehicle equipment (including a tire) covered by this notification under a sale or lease until the defect or noncompliance is remedied. By law, dealers must correct, prior to delivery for sale or lease, any vehicle that fails to comply with an applicable Federal Motor Vehicle Safety Standard or that contains a defect relating to motor vehicle safety.

Pre-Owned Vehicles in Dealer Inventory: Dealers should not deliver any pre-owned vehicles in their inventory which are involved in a safety or compliance recall until the defect has been remedied.

Dealers must ensure that every affected inventory vehicle has this campaign completed before delivery to consumers.

Parts Information

Part Number	Parts Control Type	Ordering Method Description
8V0-963-553-K	Upper Order Limit	Parts will be managed with a weekly Upper Order Limit. Please see Parts On Command (POC) for your Upper Order Limit quantity. Currently, parts are very limited and requests for additional supply above your dealerships weekly Upper Order Limit will not be approved.
N -015-261-2		

Part Number	Parts Control Type	Ordering Method Description
8V0-963-553-J	Automatic Allocation	Parts will be managed by Automatic Allocations. Please see the Repair Projection Tool for your allocation dates and quantity. Currently, parts are very limited and requests for additional supply above your dealerships weekly Automatic Allocation quantity will not be approved.

Initial Allocation: YES	Dealers will be sent an initial allocation prior to customer notification. If no initial allocation was received, please reference the Repair Projection Tool (below) to view your potential VIN population.
--	--

Repair Projection Tool:	See the latest version posted on ServiceNet.
--------------------------------	---

Criteria	Quantity	Part Number	P.O.C. Part Description	Ordering Method
01	1	8V0-963-553-K	SENSOR MAT (sport/supersport seat)	UOL
02	1	8V0-963-553-J	SENSOR MAT (standard seat)	Automatic Allocation
ALL	Up to 24	N -015-261-2	CLAMP	UOL

NOTE

The specified part numbers reflect the status at the start of this action. Interim updates made in ETKA can cause a listed part number to become unavailable. In this case, the new part number specified in ETKA should be used.

Claim Entry Instructions

The labor times listed here may differ from the labor operations and labor times listed in ELSA.

After campaign has been completed, enter claim as soon as possible to help prevent work from being duplicated elsewhere. Attach the Elsa screen print showing action open on the day of repair to the repair order.

If customer refused campaign work:

- ✓ U.S. dealers: Submit the request through Audi Warranty Online under the Campaigns/Update option.
- ✓ Canada dealers: Upload the repair order [signed by customer] to Audi WIN/Operations/Campaign Closure.

Service Number	69BY		
Damage Code	0099		
Parts Vendor Code	002		
Claim Type	Sold vehicle: 7 10 Unsold vehicle: 7 90		
Causal Indicator	Mark SENSOR MAT* as causal part		
Vehicle Wash/Loaner	Do not claim wash/loaner under this action		
Criteria I.D.	01		
	Remove front passenger seat. Replace PODS sensor mat. Program existing PODS ECU. Perform basic settings.		
	LABOR		
	Labor Op	Time Units	Description
	6956 55 99	200	Replace PODS sensor mat and program PODS ECU
	2706 89 50	10	Connect battery charger
	6956 25 99	Time stated on diagnostic protocol	Perform PODS basic settings
	PARTS		
	Quantity	Part Number	Description
	1.00	8V0963553K	SENSOR MAT*
	Up to 24	N 0152612	CLAMP

Continued on next page

Criteria I.D.	02		
	Remove front passenger seat. Replace PODS sensor mat. Program existing PODS ECU. Perform basic settings.		
	LABOR		
	Labor Op	Time Units	Description
	6956 55 99	200	Replace PODS sensor mat and program PODS ECU
	2706 89 50	10	Connect battery charger
	6956 25 99	Time stated on diagnostic protocol	Perform PODS basic settings
	PARTS		
	Quantity	Part Number	Description
	1.00	8V0963553J	SENSOR MAT*
	Up to 24	N 0152612	CLAMP

-AND-	Outside Material (CLAIM ONE TIME PER DEALER ONLY)		
	Additional tool claims will be cancelled		
	Quantity	Part number	Description
	1.00	VWAAUDI69BY	PODS Programmer
			\$35.00 USD \$43.75 CAD
<i>This reimbursement is for the VWAAUDI69BY – PODS Programmer included in the MRT Auto-Shipment AT-453 originally communicated in ATE-21-24.</i>			

Customer Letter Example (USA)

This notice applies to your vehicle: <MODEL YEAR> <BRAND> <CARLINE>, <VIN>

NHTSA: 21V198

Subject: Safety Recall 69BY – Passenger Occupant Detection System (PODS)

Dear Audi Owner,

This notice is sent to you in accordance with the National Traffic and Motor Vehicle Safety Act. Audi has decided that a defect, which relates to motor vehicle safety, exists in certain 2015-2020 model year Audi vehicles. Our records show that you are the owner of a vehicle affected by this action.

What is the issue? The passenger occupant detection system (PODS) may detect a malfunction and switch off the passenger airbag even though the seat may be occupied.

However, the airbag system and the warning strategy operate as designed. If the PODS malfunctions, a warning light in the instrument panel comes on together with an acoustic warning sound and an error message is displayed in the instrument cluster. The airbag indicator light shows "passenger airbag off". This error often occurs sporadic and for a limited amount of time. When the error and consequently the warnings disappear, the passenger airbag works again as intended without any action/interaction necessary by the customer. In the event of a crash necessitating passenger airbag activation there would be an increased risk of injury to the occupant seated in the front passenger seat if the passenger airbag is switched off/not working.

What will we do? To correct this defect, your authorized Audi dealer will replace the passenger occupant detection system (PODS) sensor mat and update the PODS control module. This work will take about four hours to complete and will be performed for you free of charge. Please keep in mind that your dealer will need to schedule your repair based on part availability. They may also need additional time for the preparation of the repair, as well as to accommodate their daily workshop schedule.

What should you do? Please contact your authorized Audi dealer without delay to schedule this recall repair. For your convenience, you can also visit www.audiusa.com and click on the "Find a Dealer" link to locate a dealer near you and schedule this service.

Precautions you should take Audi has advised that customers can continue driving these vehicles. Please ensure that everyone who uses your vehicle has read the owner's manual and is familiar with how the PODS works for the front passenger seat.

As designed, in case of a malfunction within the PODS, a warning light in the instrument panel will come on together with a warning sound and an error message will be displayed in the instrument cluster (the airbag indicator light shows "passenger airbag off"). If these warnings appear, Audi recommends that you stop using the front passenger seat and make arrangements to have the vehicle inspected/repared at an Audi dealership as soon as possible.

Lease vehicles and address changes If you are the lessor and registered owner of the vehicle identified in this action, the law requires you to forward this letter immediately via first-class mail to the lessee within ten (10) days of receipt. If you have changed your address or sold the vehicle, please fill out the enclosed prepaid Owner Reply card and mail it to us so we can update our records.

Can we assist you further? If your authorized Audi dealer fails or is unable to complete this work free of charge within a reasonable time, please contact Audi Customer Experience at 1-800-253-2834 or via our "Contact Us" page at www.audiusa.com.

Checking your vehicle for open Recalls and Service Campaigns To check your vehicle's eligibility for repair under this or any other recall/service campaign, please visit the **Recall/Service Campaign Lookup** tool at www.audiusa.com and enter your Vehicle Identification Number (VIN).

If you still cannot obtain satisfaction, you may file a complaint with: The Administrator, National Highway Traffic Safety Administration, 1200 New Jersey Avenue, SE., Washington, DC 20590; or call the toll-free Vehicle Safety Hotline at 1-888-327-4236 (TTY: 1-800-424-9153); or go to <http://www.safercar.gov>.

We apologize for any inconvenience this matter may cause; however we are taking this action to help ensure your safety and continued satisfaction with your vehicle.

Sincerely,

Audi Customer Protection

The repair information in this document is intended for use only by skilled technicians who have the proper tools, equipment and training to correctly and safely maintain your vehicle. These procedures are not intended to be attempted by "do-it-yourselfers," and you should not assume this document applies to your vehicle, or that your vehicle has the condition described. To determine whether this information applies, contact an authorized Audi dealer. ©2021 Audi of America, Inc. and Audi Canada. All Rights Reserved.

Customer Letter Example (Canada)

<MONTH YEAR>

<CUSTOMER NAME>

<CUSTOMER ADDRESS>

<CUSTOMER CITY STATE ZIPCODE>

This notice applies to your vehicle: <MODEL YEAR> <BRAND> <CARLINE>, <VIN>

Transport Canada Recall: 2021-169

Subject: Safety Recall 69BY – Passenger Occupant Detection System (PODS)

Dear Audi Owner,

This notice is sent to you in accordance with the requirements of the *Motor Vehicle Safety Act*. This is to inform you that your vehicle may contain a defect that could affect the safety of a person. Our records show that you are the owner of a vehicle affected by this action.

What is the issue? The passenger occupant detection system (PODS) may detect a malfunction and switch off the passenger airbag even though the seat may be occupied.

However, the airbag system and the warning strategy operate as designed. If the PODS malfunctions, a warning light in the instrument panel comes on together with an acoustic warning sound and an error message is displayed in the instrument cluster. The airbag indicator light shows "passenger airbag off". This error often occurs sporadic and for a limited amount of time. When the error and consequently the warnings disappear, the passenger airbag works again as intended without any action/interaction necessary by the customer. In the event of a crash necessitating passenger airbag activation there would be an increased risk of injury to the occupant seated in the front passenger seat if the passenger airbag is switched off/not working.

What will we do? To correct this defect, your authorized Audi dealer will replace the passenger occupant detection system (PODS) sensor mat and update the PODS control module. This work will take about four hours to complete and will be performed for you free of charge. Please keep in mind that your dealer will need to schedule your repair based on part availability. They may also need additional time for the preparation of the repair, as well as to accommodate their daily workshop schedule.

What should you do? Please contact your authorized Audi dealer without delay to schedule this recall repair.

Precautions you should take Audi has advised that customers can continue driving these vehicles. Please ensure that everyone who uses your vehicle has read the owner's manual and is familiar with how the PODS works for the front passenger seat.

As designed, in case of a malfunction within the PODS, a warning light in the instrument panel will come on together with a warning sound and an error message will be displayed in the instrument cluster (the airbag indicator light shows "passenger airbag off"). If these warnings appear, Audi recommends that you stop using the front passenger seat and make arrangements to have the vehicle inspected/repared at an Audi dealership as soon as possible.

Lease vehicles and address changes If you are the lessor and registered owner of the vehicle identified in this letter, you shall forward this letter (and any subsequent notice, if applicable) to the lessee within ten (10) days of receipt. If you have changed your address or sold the vehicle identified in this letter, please fill out the enclosed prepaid Owner Reply Card and mail it to us so we can update our records.

Can we assist you further? If your authorized Audi dealer fails or is unable to complete this work free of charge within a reasonable time, please contact Audi Customer Relations Monday through Friday from 8AM to 8PM EST at 1-800-822-2834 or via our "Contact Audi Canada" page at www.audi.ca.

We apologize for any inconvenience this matter may cause; however we are taking this action to help ensure your safety and continued satisfaction with your vehicle.

Sincerely,

Audi Customer Protection

Repair Overview

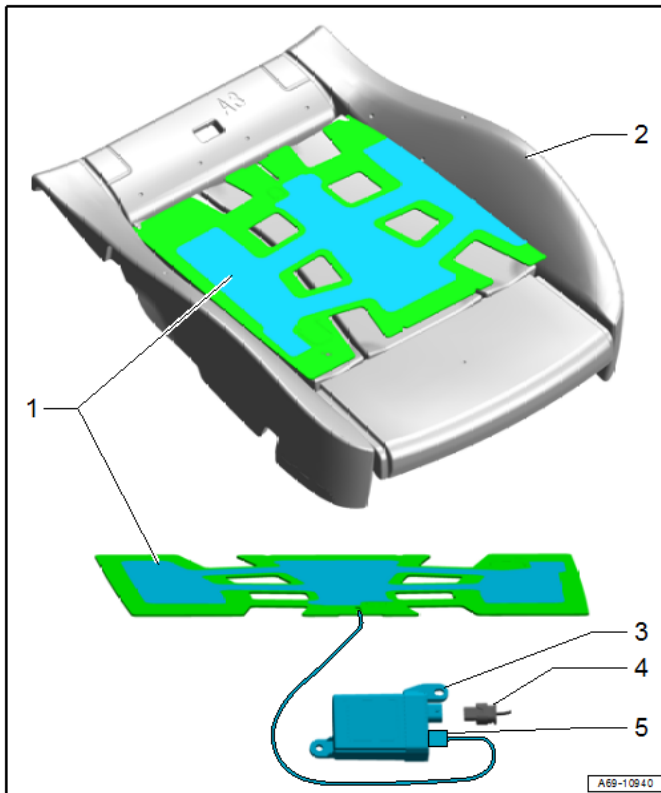

- Replace PODS sensor mat.
- Program existing PODS ECU.
- Perform PODS Basic Settings.

NOTE

This repair addresses the following faults that could be potentially stored in the airbag control module:

- B12251B: Passive occupant detection system mat, Resistance too high
- B102229: Passenger occupant detection system control module, Range/Performance
- B102202: Passenger occupant detection system control module, Signal malfunction

NOTE

- These repair instructions may differ from the labor operations and labor times listed in ELSA.
- Damages resulting from improper repair or failure to follow these work instructions are the dealer's responsibility and are not eligible for reimbursement under this action.
- This procedure must be read in its entirety prior to performing the repair.
- Due to variations in vehicle equipment and options, the steps/illustrations in this work procedure may not identically match all affected vehicles.
- Diagnosis and repair of pre-existing conditions in the vehicle are not covered under this action.
- When working during extreme temperatures, it is recommended that the vehicle be allowed to acclimate inside the shop to avoid temperature-related component damage/breakage.

Required Tools

 <p>Battery Tester/Charger - GRX3000VAS- (or equivalent)</p>	 <p>Diagnostic Tester -VAS6150X- (or equivalent)</p>	
 <p>Trim Removal Wedge -3409- (or equivalent)</p>	 <p>Universal Vehicle Protector -VAS871001- (or equivalent)</p>	
 <p>Engine and Transmission Holder -VAS6095A-</p>	 <p>Engine/Transmission Holder - Seat Repair Fixture -VAS6136-</p>	
 <p>Airbag Lockout Adapter -VAS6282-</p>	 <p>Backrest Panel Tool -3370-</p>	

Continued on next page



Assembly Tool
-3399-
(Manual Seats Only)



T-Handle Hook
-3438-
(Manual Seats Only)



Upholstery Clip Pliers
-VAG1634B-
(or equivalent)



PODS Programmer
-VWAAUDI69BY-

Repair Instruction

Section A - Check for Previous Repair

Applicable criteria ID(s)	Campaign/Action Status
01 ← 2	Open ← 1

EXAMPLE

Campaign/Action	Start	Designation
→ 3	2015-11-10	W-SERV_ACT -
	2018-12-13	RECALL -
	2017-05-16	A-RECALL -

EXAMPLE

- Enter the VIN in Elsa and proceed to the “Campaign/Action” screen.

TIP

On the date of repair, print this screen and keep a copy with the repair order.

- Confirm the Campaign/Action is open <arrow 1>. If the status is closed, no further work is required.
- Note the Applicable Criteria ID <arrow 2> for use in determining the correct work to be done and corresponding parts associated.

CRITICAL REPAIR STEP

 **STOP!** 

If multiple software update Campaign/Actions are open, they must be performed in order of the Start date <arrow 3>. The oldest should be performed first.

- **All Safety Recalls must be completed prior to completing this campaign.**
- **Proceed to Section B.**

Section B – Repair Procedure

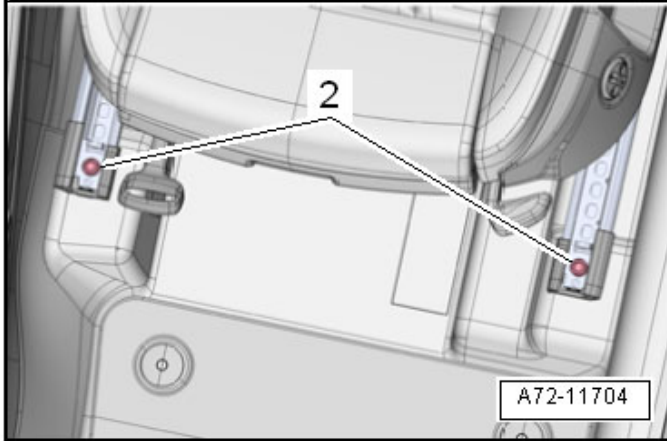
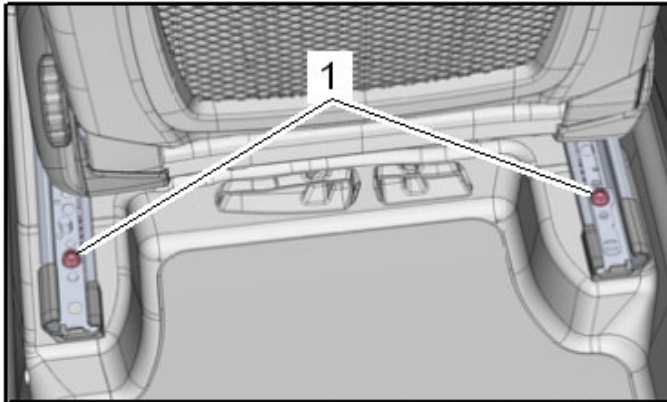

Unbolt seat:

- Push the headrest into the lowest position.
- Move the front seat all the way to the rear and then into its lowest position.
- Remove seat bolt covers.
- Remove front bolts <2> from the seat rail.
- Move the front seat all the way forward and up.
- Remove the rear bolts <1> from the seat rail.

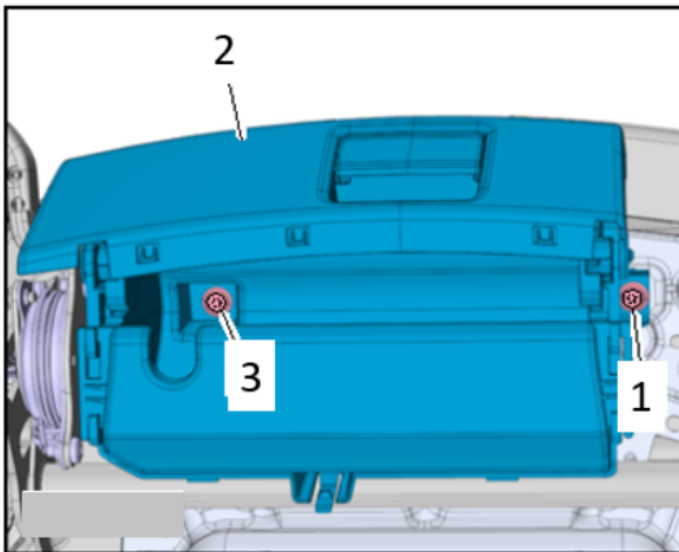

Remove storage compartment (if equipped):

- Handle the customer's property with care.
- Remove the bolts <1 and 3>.



- Press down on the seat bottom tilt adjustment.

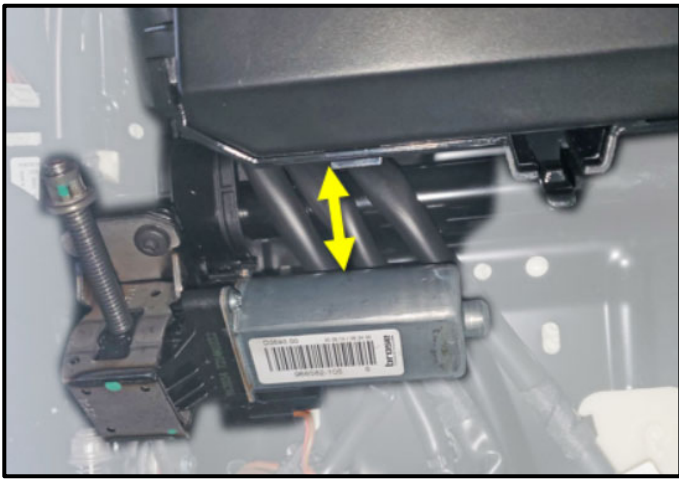

! NOTE

Moving the front tilt adjustment position to its lowest position will provide the necessary clearance to allow removal of the storage compartment.

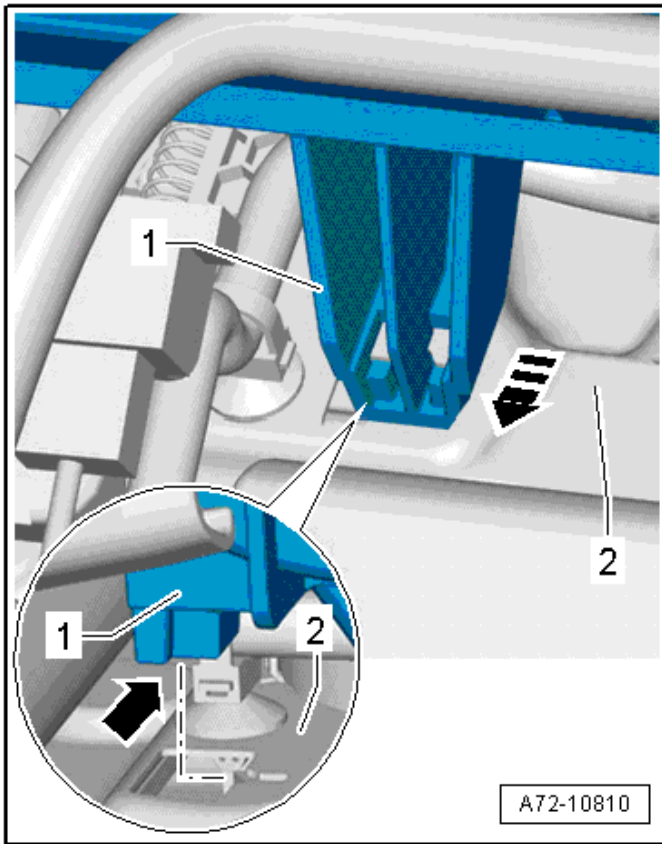

- Push the storage compartment rearward <1> in the direction of the <arrow> and disengage the retainer <lower arrow> from the upper seat frame <2>.
- Remove the storage compartment from the seat pan upper frame.
- Unclip the Passenger Occupant Detection System Control Module -J706-.

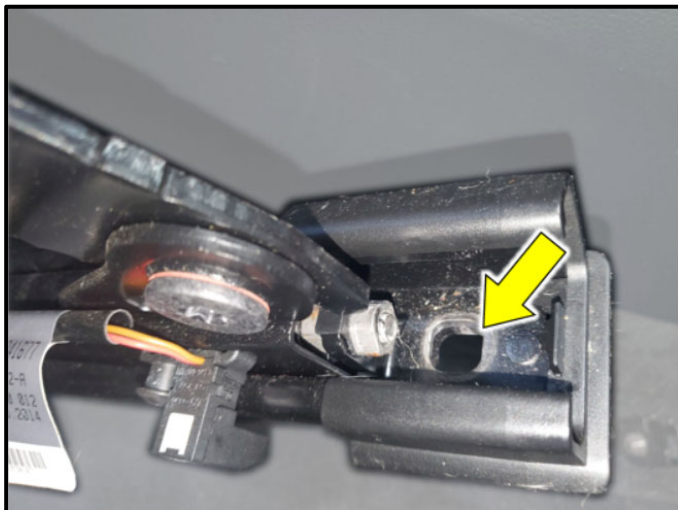

Position seat for removal:

- Move seat to its highest position.
- Move seat toward the rear so the front hole <arrow> for the seat frame bolt can be accessed (as shown).
- Ensure the rear holes for the seat frame bolts can also be accessed.

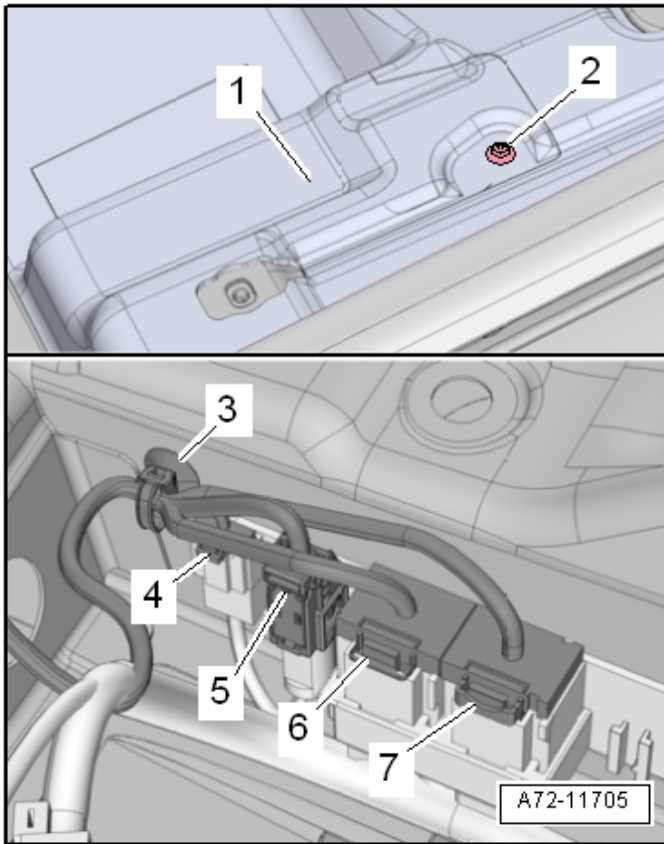

Disconnect connectors:

- Remove the expanding clip <2> and fold up the section of the carpet <1>.
- Unclip the cable holder <3>.

⚠ WARNING

Before handling pyrotechnic components (for example, disconnecting the connector), the person handling it must “discharge static electricity”. This can be done by touching the door striker, for example.

⚠ CAUTION

The ignition must be switched off before disconnecting airbag connector <5>.

- Disconnect the connectors in the specified order from the connector station.
 - 7 - Power Supply
 - 6 - If equipped with seat heater
 - 5 - Thorax Airbag
 - 4 - Seat Belt Latch
- Connect the -VAS6282- to the thorax airbag harness connector.

! NOTE

The number of connectors present in the connector station will vary based on vehicle equipment.



Install -VAS871001-:

- To protect the sill panel before removing the front seat, install the Universal Vehicle Protector -VAS871001- <as shown>.
- Carefully remove the front seat from the vehicle.

! NOTE

Due to the weight and size of the front passenger seat, assistance from a second technician may be helpful in removing the seat.



Attach seat to -VAS6136-:

- Attach the Seat Repair Fixture -VAS6136- to the Engine and Transmission Holder -VAS6095-.
- Fasten the front seat onto the Seat Repair Fixture -VAS6136-.

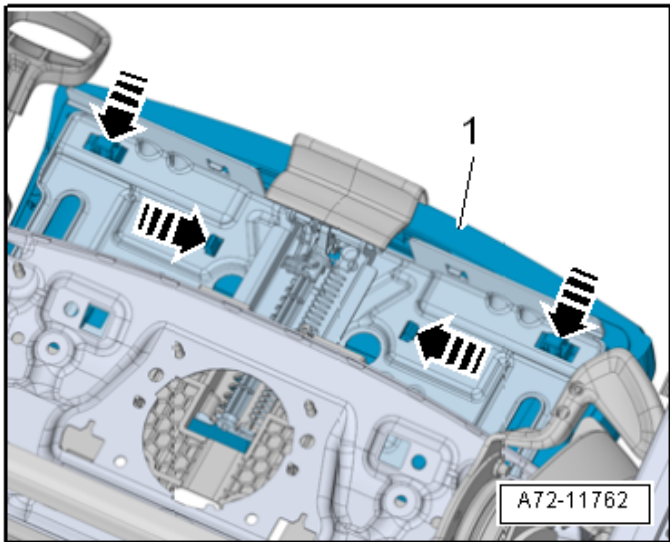

Disengage seat depth adjuster cushion (if equipped):

- Release the retaining tabs <arrow> on the support using the -3409- from the seat depth adjuster.
- Remove the support <1> with seat depth adjustment cushion and cover upward.

! NOTE

Seat depth adjuster trim does not require removal.

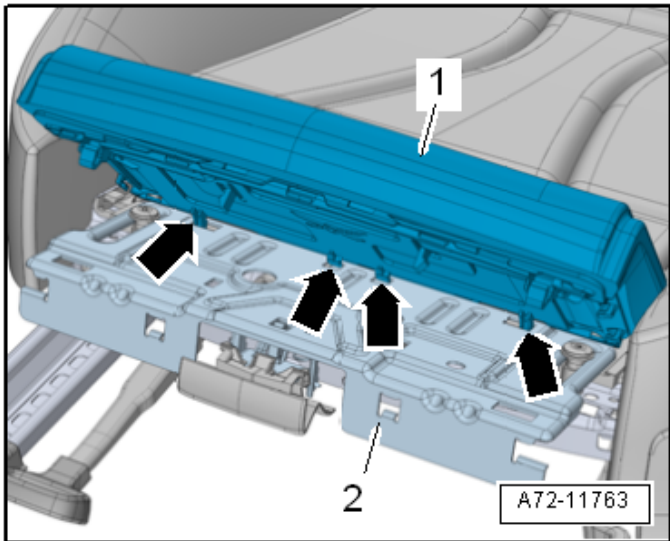

- Disengage the tabs <arrows> from the seat depth adjuster <2> and move the support with cushion and cover upward.
- Remove the support <1> with cushion and cover for the seat depth adjuster upward and forward at the same time.

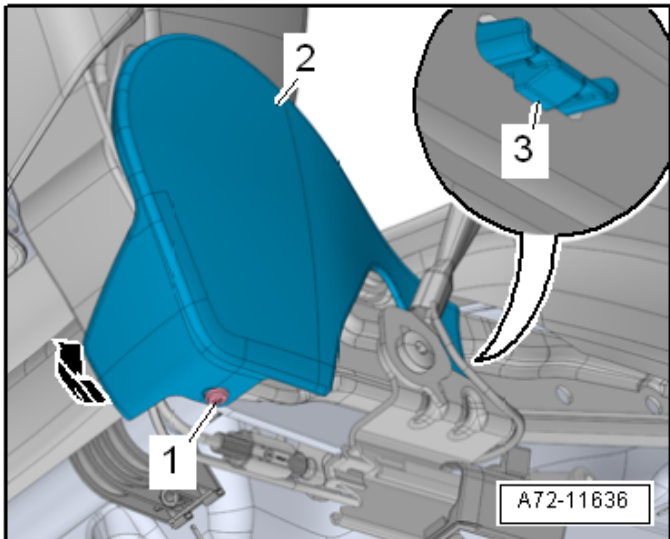

Remove tunnel side seat trim:

- Remove the expanding rivet <1> from the seat side trim on the tunnel side.
- Disengage the front seat side trim <2> from the seat pan, to do this release the retaining tab <3> and pull the seat side trim outward.
- Disengage the seat side trim on the tunnel side from the backrest hinge in direction of <arrow> and remove.

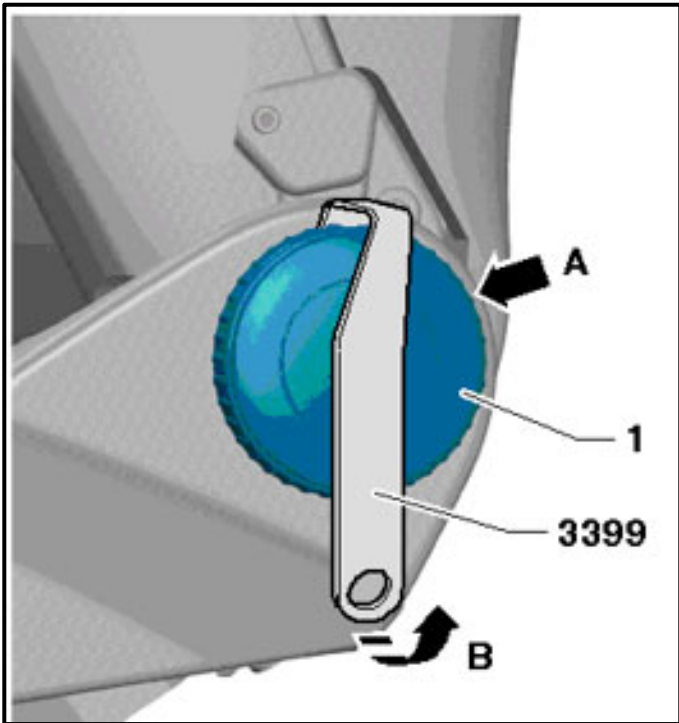

Remove backrest adjustment hand wheel (MANUAL seats):

- Turn the seat back adjustment wheel <1> until one catch is visible from behind <arrow A>. Use a flashlight if necessary.
- Using the Assembly Tool -3399-, carefully pry the adjustment wheel off the seat <direction of arrow B>.
- Turn the seat back adjustment wheel 120° further and repeat the process.
- Remove the seat back adjustment wheel.

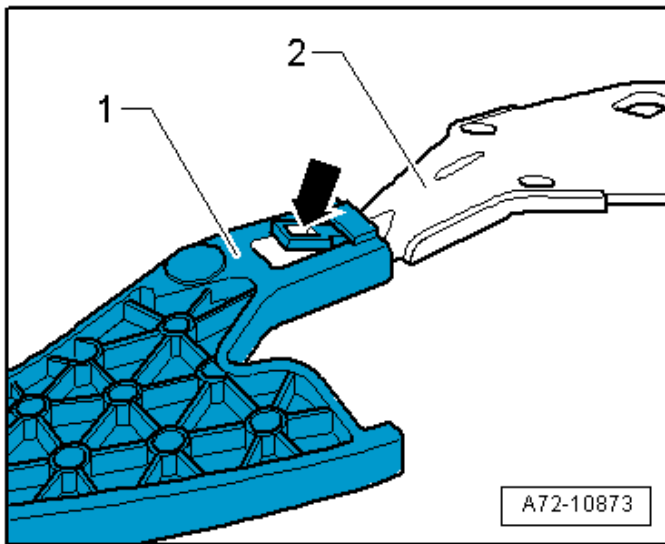

Remove seat height adjuster handle (MANUAL seats):

⚠ CAUTION

There is a risk of destroying the seat height adjuster handle if removed improperly.

Remove the seat height adjustment handle <1> as described, do not drive it off the lever <2>.

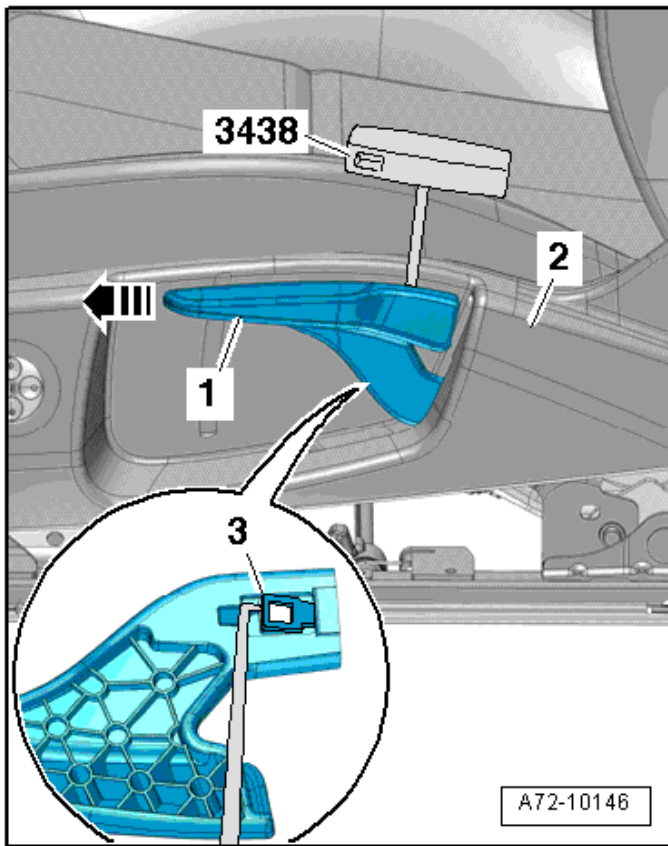

- Pull the seat height adjustment handle <1> slightly upward and hold in this position.
- Remove the seat height adjustment handle as far as possible from the front seat.
- Guide the -3438- between the seat height adjustment handle and seat side trim <2>.
- Release the tab <3> with the -3438- and at the same time remove the seat height adjustment handle in the direction of the <arrow> from the lever.

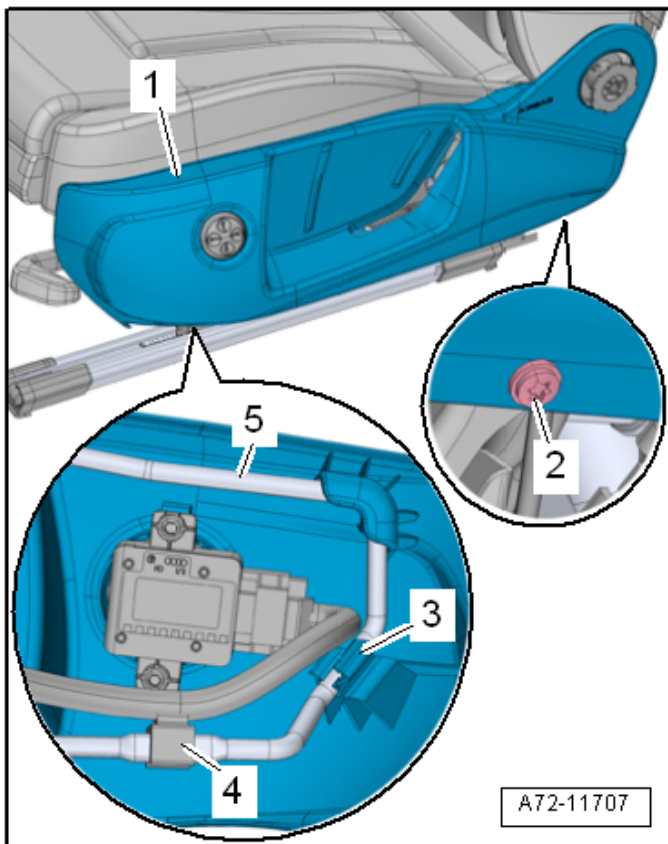

Remove side trim and bracket on sill side (MANUAL seat):

- Remove the expanding rivet <2> from the seat side trim.
- Open the clip <3> with a screwdriver.
- Disengage the rear seat trim on side sill side <1> from the backrest hinge and the seat pan.
- Slightly lift the front seat side sill trim, unclip from the bracket <5> and remove forward.
- Equipment versions with lumbar support: unclip the cable holder <4> and disconnect the connector from the lumbar support adjustment switch.

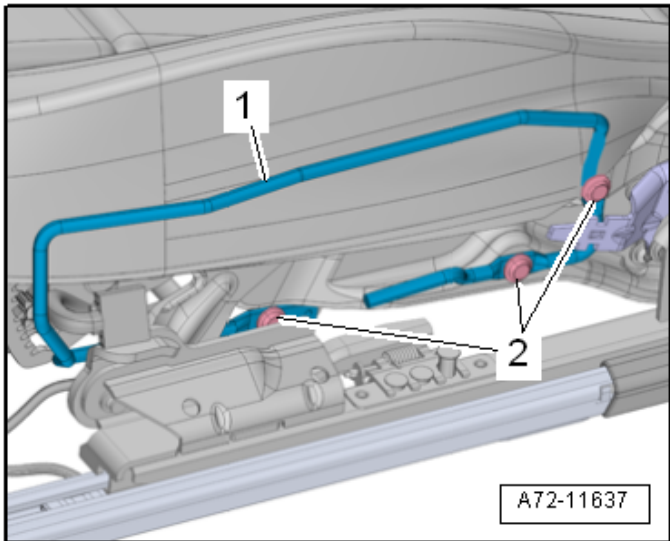

- Remove the bolts <2> and remove the bracket <1>.

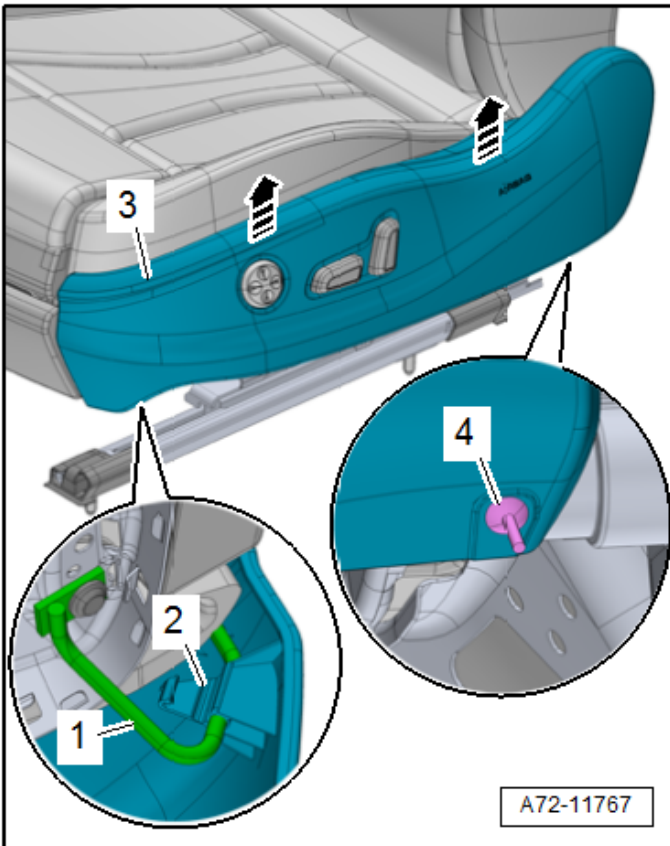

Remove side trim and bracket on sill side (POWER seat):

- Remove the expanding rivet <4> from the seat side trim.
- Open the clip <2> with a screwdriver.
- Disengage the seat side sill trim <3> from the backrest hinge and seat frame.
- Slightly lift the front seat side trim, and unclip from the bracket <1>.
- Slightly lift the rear seat side trim, disengage from the bracket <arrows> and remove forward.

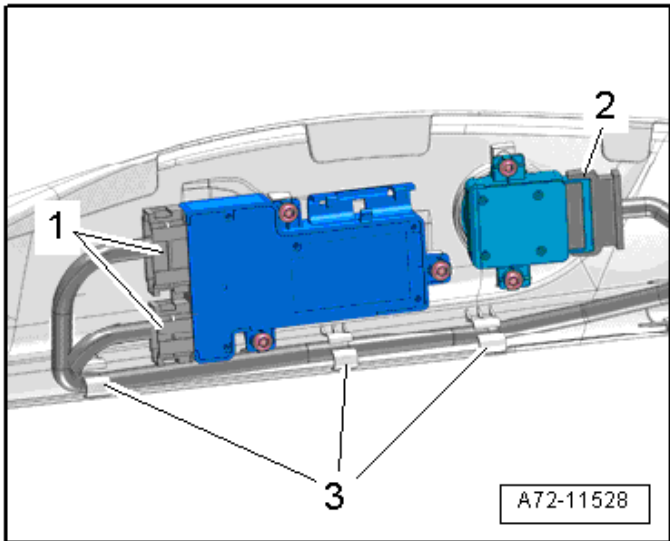

- Disconnect the connectors:
 - 1 - Driver Seat Adjustment Control Head -E470-/ Front Passenger Seat Adjustment Control Head -E471-.
 - 2 - Driver Seat Lumbar Support Adjustment Switch -E176-/ Front Passenger Seat Lumbar Support Adjustment Switch -E177-.
- Free up electrical wire on the bracket <3>.
- Remove the seat side trim.

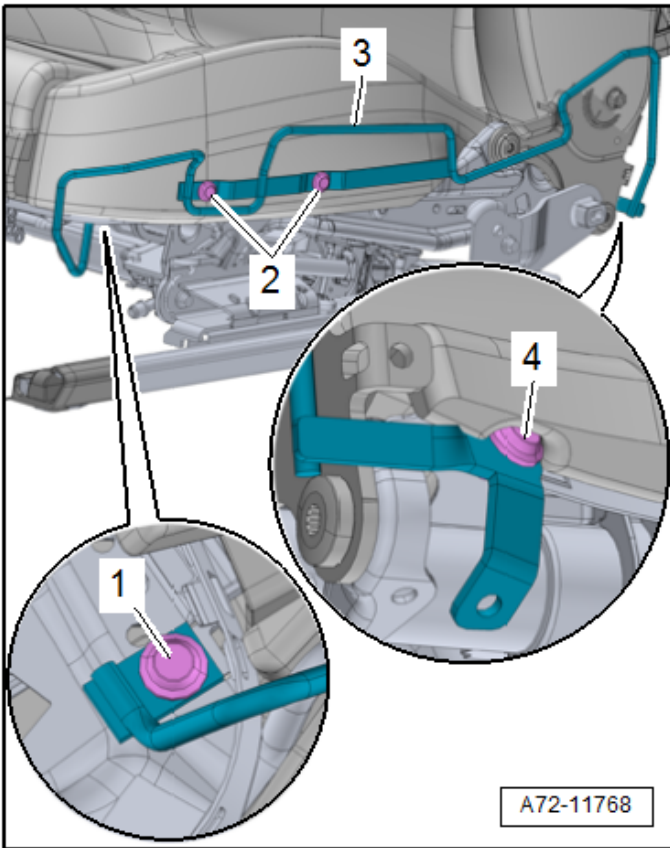

- Remove the bolts <1, 2, and 4> and remove the bracket <3>.

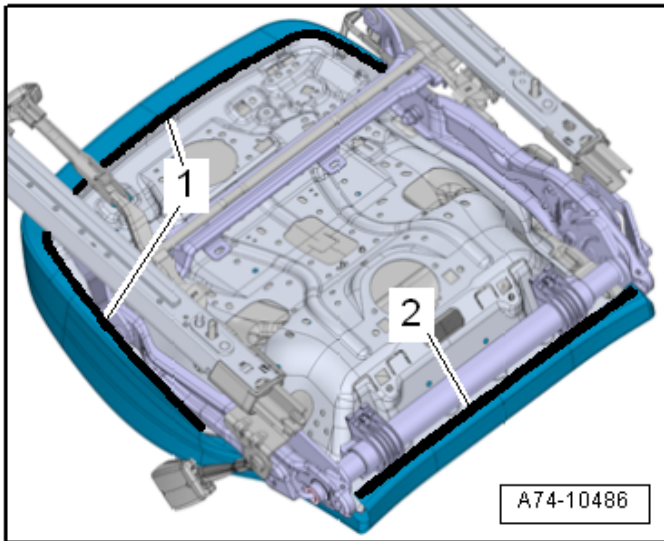

Detach seat cushion from seat pan (STANDARD seats):

- Detach the molding <1> from the seat cover in the front and side areas using the -3370-.
- Detach the molding <2> of the cover in the rear area using the -3370-.

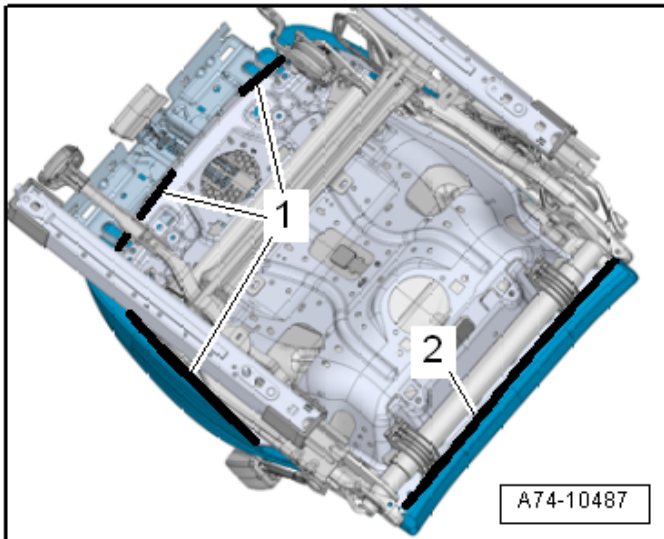

Detach seat cushion from seat pan (SPORT/SUPER-SPORT seats):

- Disengage the molding <1> on the side, and the molding <2> in the area of the rear cover using the -3370-.

NOTE

The seat depth adjuster support (plastic) remains on the padding.

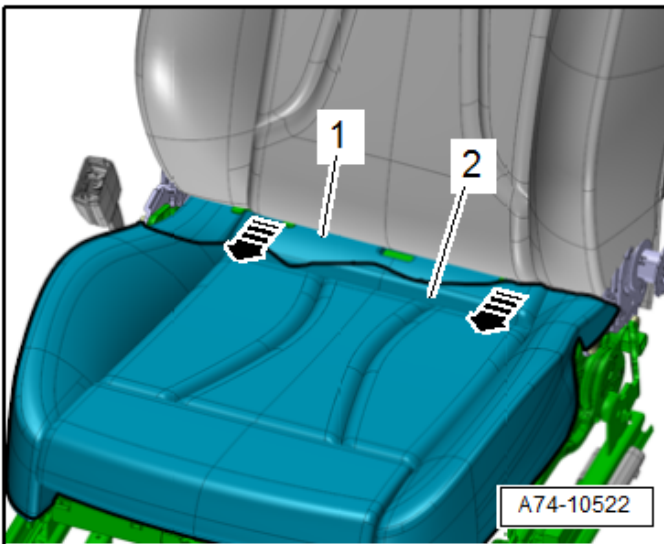

- Carefully disengage the cushion <1> with cover <2> at the rear of the seat pan <arrows>.
- Remove the cover and cushion from the seat pan, while doing so if necessary free up the seat heating wiring harness.

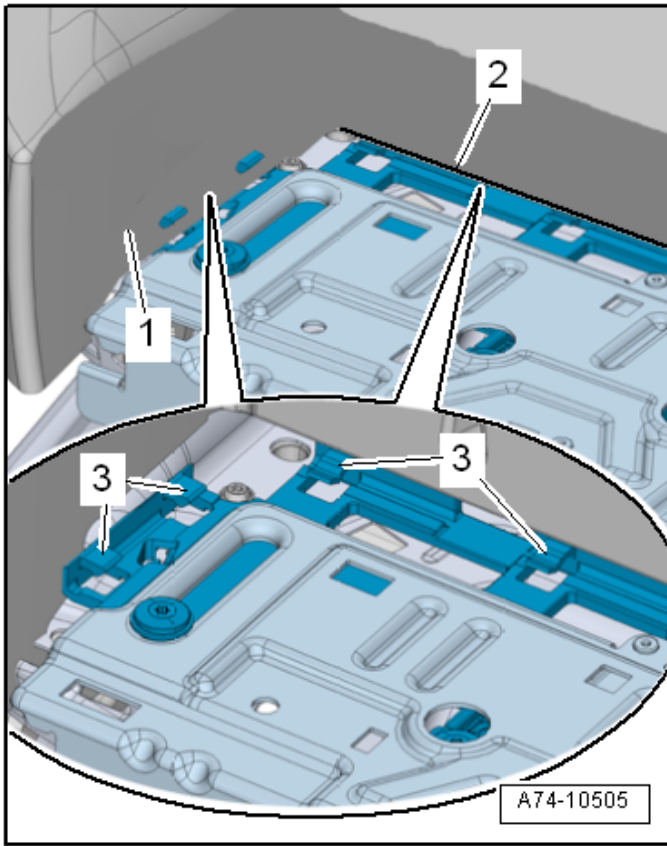

Disengage seat covering from seat depth adjuster:

- Disengage the cushion <1> at the sides from the tabs <3>.

⚠ CAUTION

There is a risk of damaging the tabs.

- Proceed very carefully when clipping and unclipping.
- Using pliers to carefully grasp the plastic edge of the seat cover molding (circle) and gently pulling the molding out of the tabs <3> in the direction of <arrow>, will prevent damage to the tabs <3>.





Prepare seat:

- To prevent damage to the seat backrest, place clean towels on the backrest.

Free up wiring harnesses:

NOTE

- Take photos of wiring harness location prior to removal.
- There may be slight variations of harness routing depending on vehicle equipment.

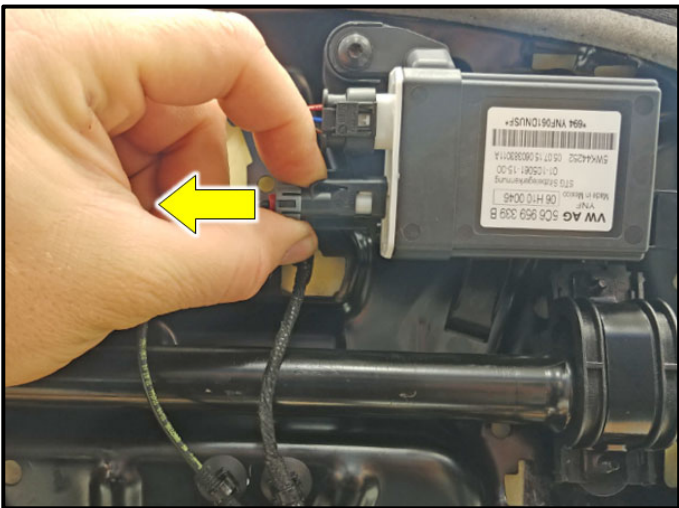

CAUTION



The connector must be removed exactly parallel with the PODS ECU. The center pin in the PODS ECU is fragile and must not be bent during removal. A damaged center pin will cause PODS faults. Damage to PODS ECU is not covered under this action.

- Press down on locking tab and remove PODS sensor connector <1> from PODS ECU <2> in <direction of arrow>.

NOTE

Version without storage compartment shown.

NOTE

- During the 69BY recall repair it is ok to disconnect the sensor mat from the PODS ECU.
- The replacement PODS mats do not come with a new PODS ECU.
- The existing PODS ECU will be updated with new parameters during this recall repair.

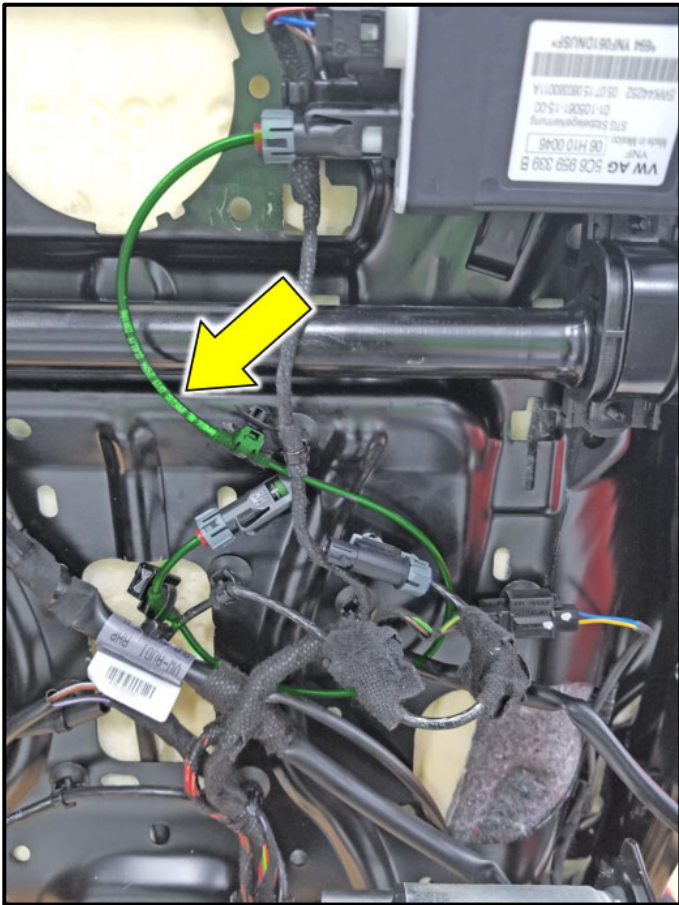

- If present, disconnect and discard 69Z4 PODS repair wiring harness <arrow>.

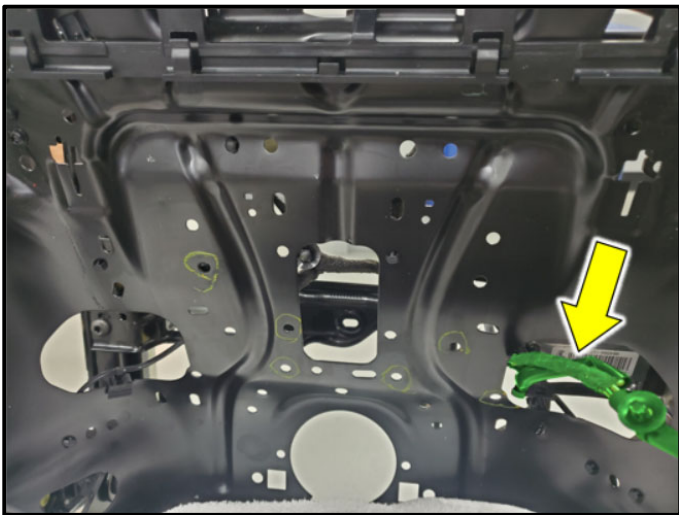

- Unclip the seat wiring harness and disconnect connectors as needed to gain enough slack in the wiring harness.
- Mark the location of each wiring harness clip that is removed.
- When reinstalling the wiring harness, the harness must be routed in the same location.
- There should be enough slack in the seat wiring harness <arrow> so the work on the seat bottom can be performed without putting any strain on the seat wiring harness.

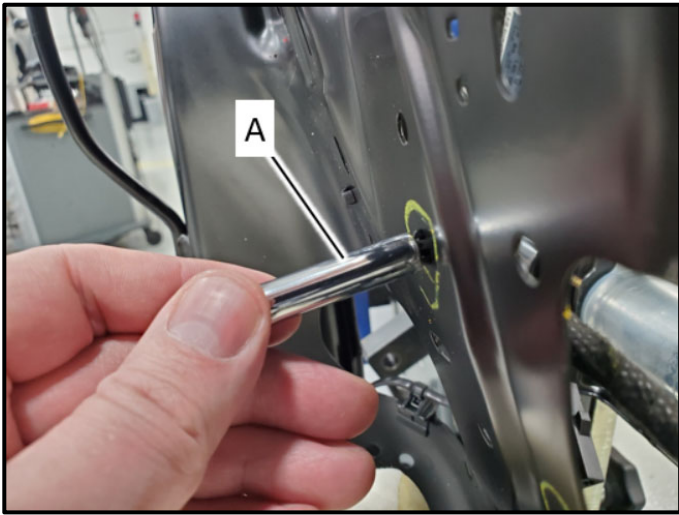

- To prevent damage to the clips, use a 6 mm, 6-point socket <A> and press it over the locking tabs from the seat cushion side of the seat pan.
- If access is not available, use needle nose pliers to compress the locking tabs.

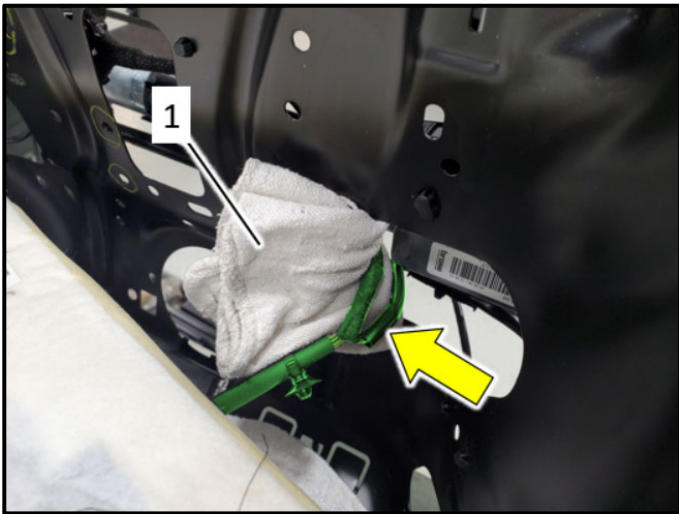

- Place a protective cloth <1> between the seat pan openings and wiring harness <arrow> to prevent damage to the seat wiring harness.

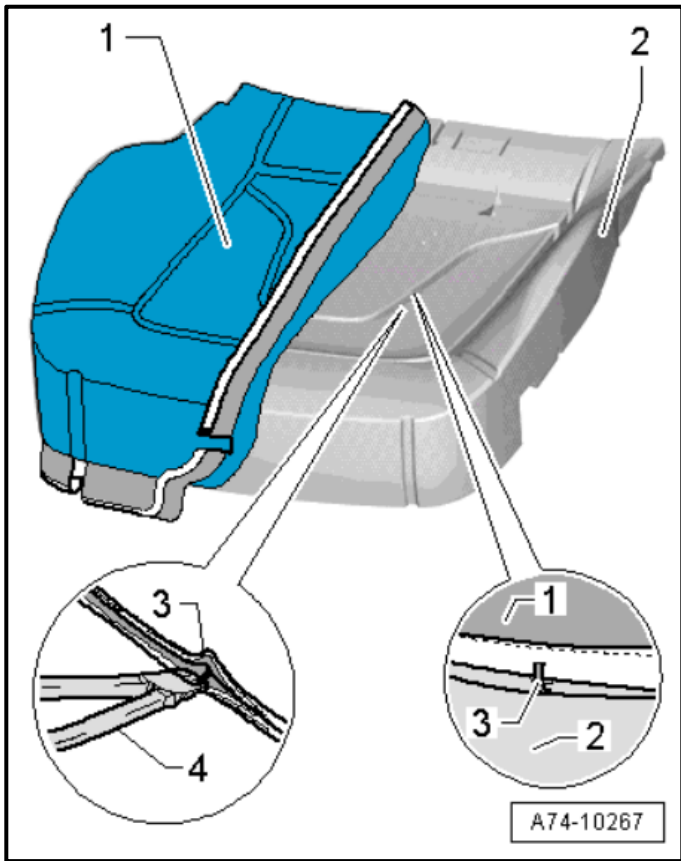

Separating seat cover and cushion (STANDARD seats):

- Remove seat cover <1> in the rear and side from the seat cushion <2> and cut upholstery clips <3> using pliers <4>.

NOTE

The seat cover will have approximately 24 upholstery clips installed. While cutting these clips, some fragments may remain attached to the seat cover and cushion. **ALL** fragments of the old clips **MUST** be removed from the seat cover and cushion prior to reassembling the seat.

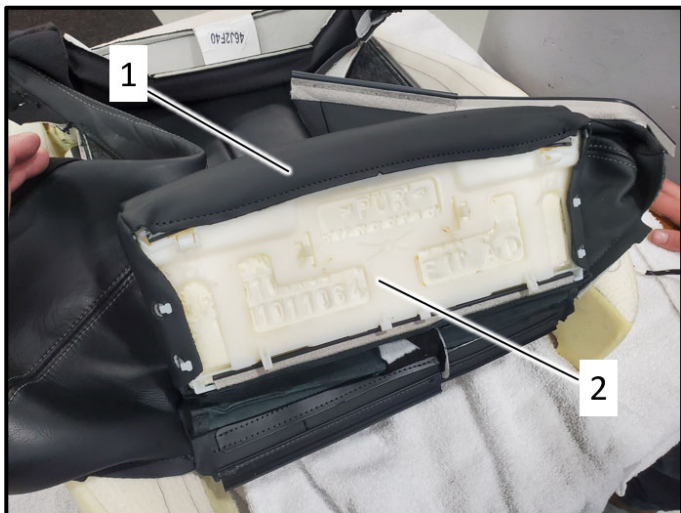

Separating seat cover and cushion (SPORT/SUPER-SPORT seats):

NOTE

The seat covering <1> does not require removal from the seat depth adjuster cushion <2>.

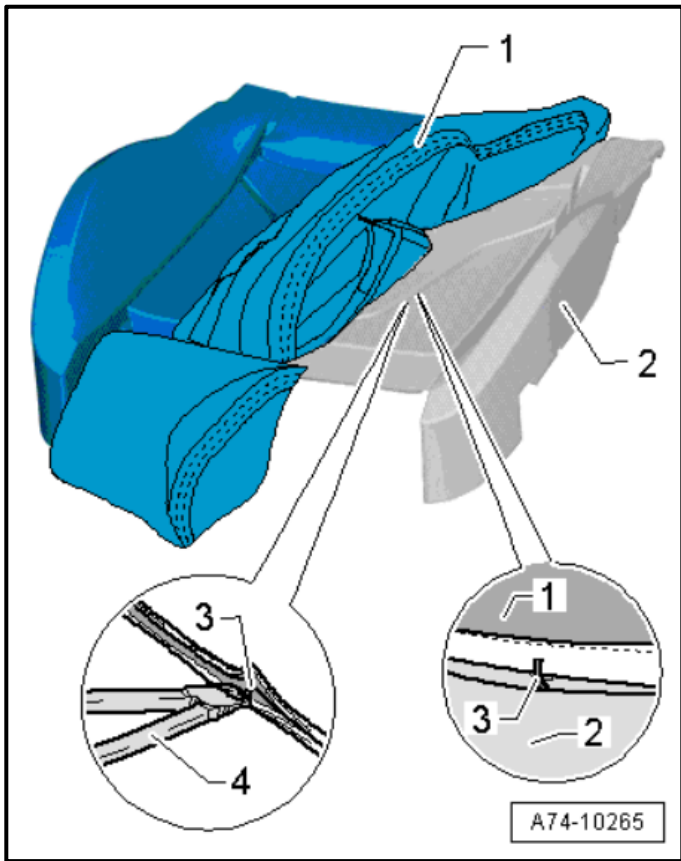

- Remove cover <1> from the cushion <2> and cut upholstery clips <3> using pliers <4>.

NOTE

The seat cover will have approximately 24 upholstery clips installed. While cutting these clips, some fragments may remain attached to the seat cover and cushion. **ALL** fragments of the old clips **MUST** be removed from the seat cover and cushion prior to reassembling the seat.

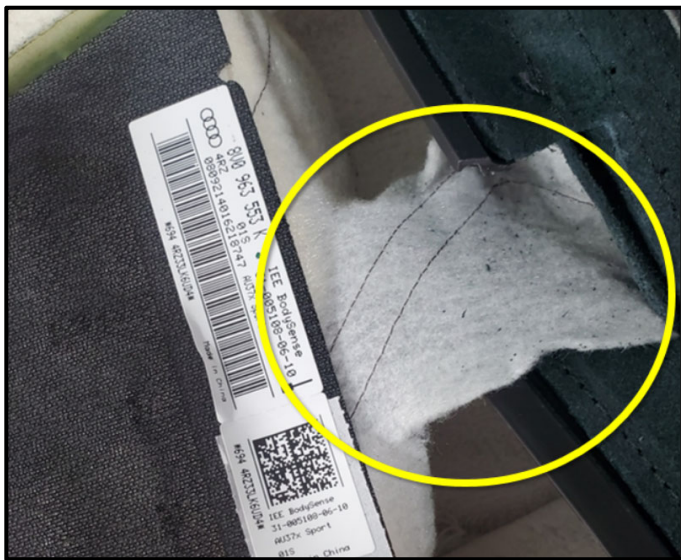

CAUTION

Sport/Supersport seats:
Ensure the seat heating element bridge <circle> is not twisted or damaged.



Before removing the sensor mat from the seat cushion, verify the resistance of the seat heater element (if equipped):

- Check and record the resistance between pins 3 and 4 of the T6j connector.
- Checking the resistance prior to removing the PODS sensor mat confirms the integrity of the seat heater element.
- If the seat heating element is found damaged (open circuit or high resistance) prior to replacing the PODS sensor mat, the customer must be informed.



Removing PODS Sensor Mat:

⚠ CAUTION

Risk of Injury

Surface of PODS sensor mat will be hot. Wear protective gloves.

⚠ CAUTION

Risk of Consequential damage

Seat heating element fabric and seat foam can be damaged.

Do not use a high heat setting.

Keep the heat gun moving. Do not hold the heat on one location

- Use a heat gun set to Low/Medium heat.
- Alternately heat the PODS sensor mat surface still adhered to the seat cushion and behind the PODS sensor mat (as shown), while carefully and slowly pulling the PODS sensor mat away from the seat cushion.
- Pull in the direction of <arrow>.
- Only pull upward at a very slight angle.
- DO NOT pull up perpendicular to the seat cushion surface.
- Remove each section equally.
- Carefully pull wiring harness through the seat cushion.

⚠ NOTE

Sport/Supersport seat shown. Procedure for standard seat is similar.

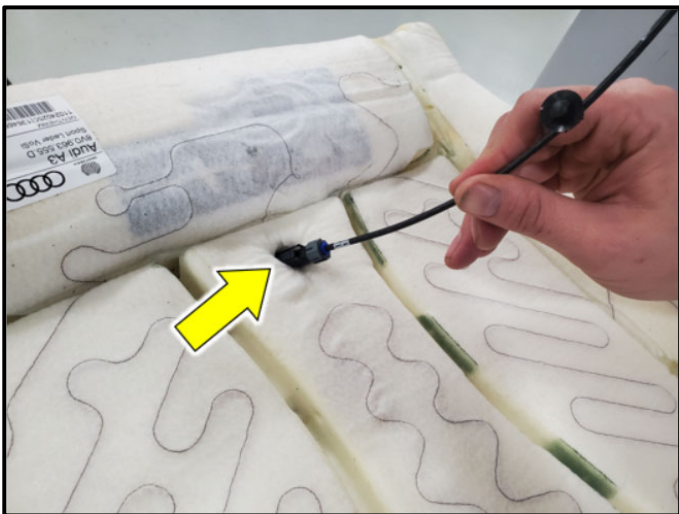

Installing PODS Sensor Mat:

- Carefully insert wiring harness through hole <arrow> in the seat cushion.

⚠ NOTE

Sport/Supersport seat shown. Procedure for standard seat is similar.

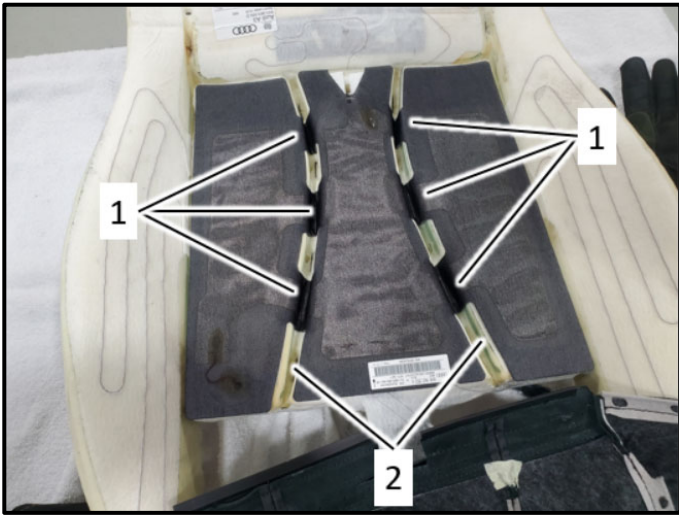

- Remove the protective backing from only one section of the PODS mat at a time.
- Adhere only one section of the PODS mat to the seat cushion at a time.
- Ensure there are no wrinkles or large air pockets between the PODS sensor mat and the seat cushion.
- Sport/Supersport seats - adhere the center section first before adhering each side section.
- Ensure each “bridge section” <1> is pressed evenly into the valleys <2> of the seat cushion.

NOTE

- Sport/Supersport seat shown.
- Standard seats only have two PODS sensor mat sections and only one valley.
- Procedure for standard seat is similar. Fully adhere one section before adhering the second section.

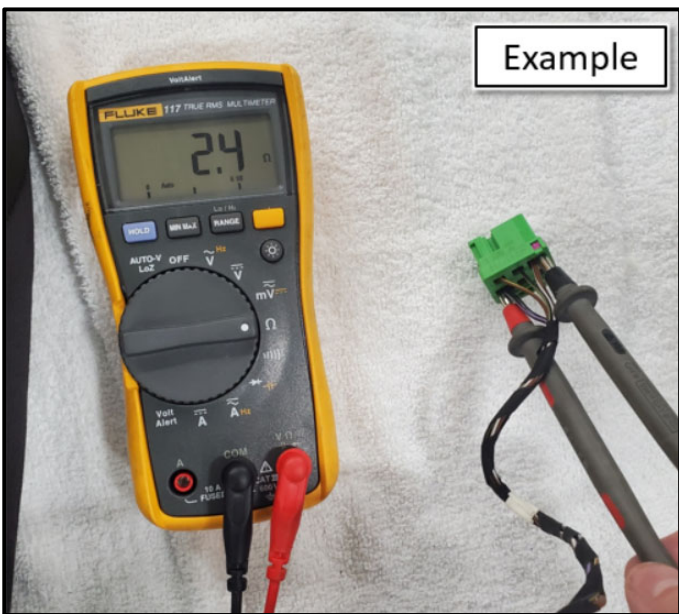

Verify seat heater resistance:

- Check and record the resistance between pins 3 and 4 of the T6j connector.
- Checking the resistance after installing the PODS sensor mat confirms the integrity of the seat heater element.



Transfer identification label:

- Locate the QR code sticker <circle> on the new PODS mat and tear off at the perforation.



- Apply the QR code sticker over the existing sticker on the seat frame.

! NOTE
The location of the existing sticker on the seat frame may vary.



Reinstall seat cover:

- Installation is the reverse order of removal.
- Start at the center rows and work outward using Upholstery Clip Pliers -VAG1634B-.

Part Number	Part Description
N -015-261-2	Upholstery Clamps

⚠ CAUTION
Ensure the sensor mat and seat heater are not damaged/pinched when installing clamps,

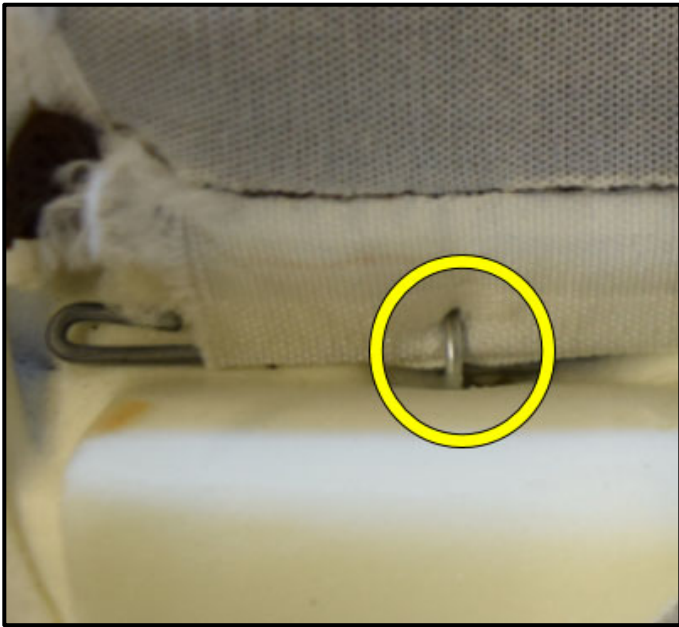

- Prior to fully clamping the upholstery clips closed, be sure each upholstery clip engages BOTH the webbing on the bottom side of the seat cover AND the fastening wire molded into the seat cushion as shown <circle>.

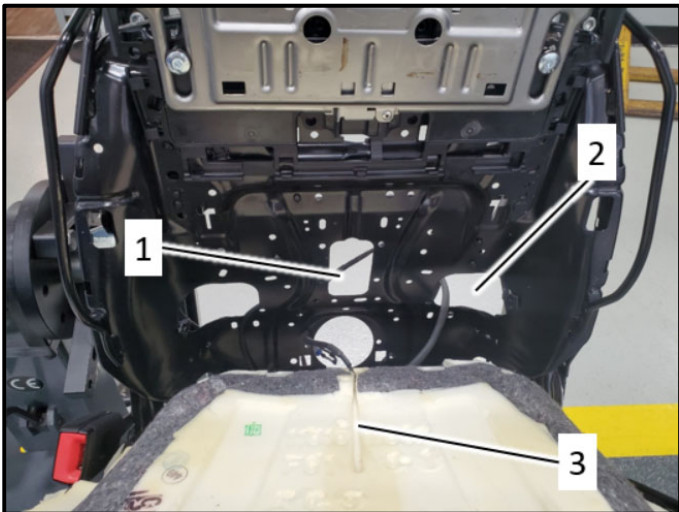

Reinstall seat cushion:

- PODS sensor mat harness is routed through hole <1>.
- Seat heater wiring harness (if equipped) is routed through hole <2>.
- Ensure the PODS sensor mat harness is engaged into channel <3>.

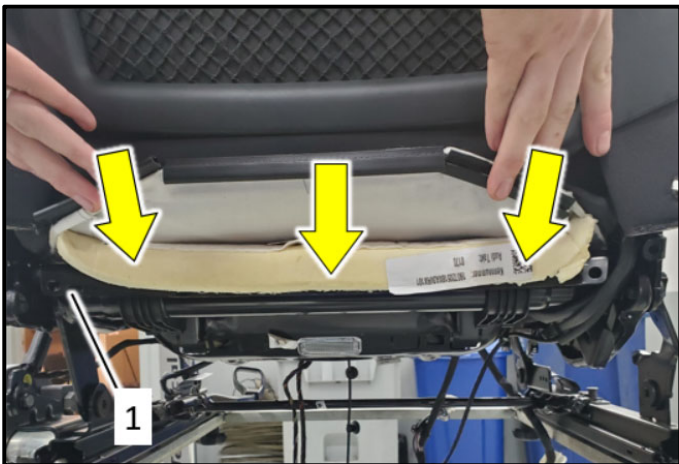

- Ensure seat foam <arrows> is fully engaged over the rear of the seat pan <1>.

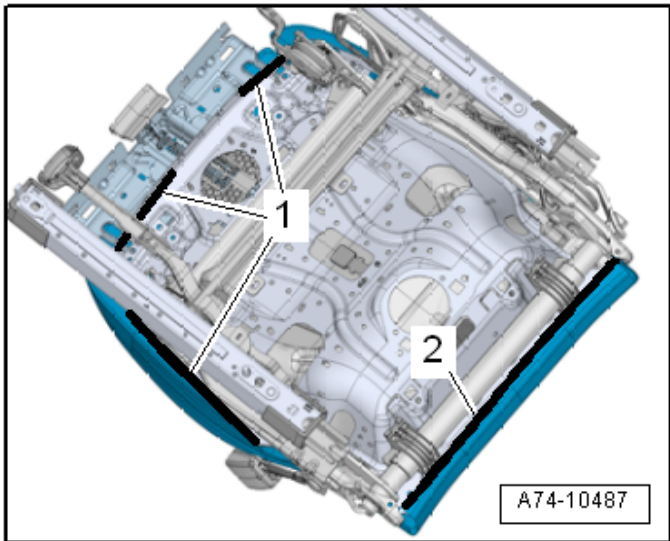

- Engage the molding <1> and <2> onto the seat pan.

Connect PODS sensor mat:

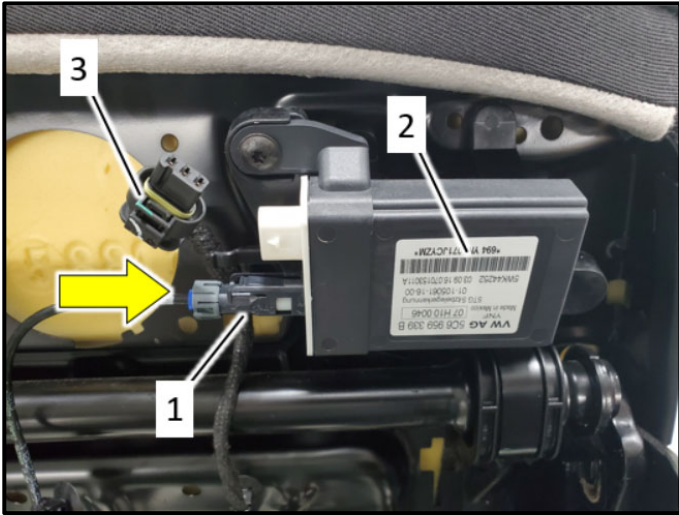

CAUTION



The connector must be installed exactly parallel with the PODS ECU. The center pin in the PODS ECU and connector is fragile and must not be bent during installation. A damaged center pin will cause PODS faults. Damage to the PODS ECU is not covered under this action.

- Connect PODS sensor wiring connector <1> to PODS ECU <2> in <direction of arrow>.
- Disconnect connector <3>.

NOTE

The PODS ECU will be updated using the PODS Programmer at PODS ECU connection <3>.

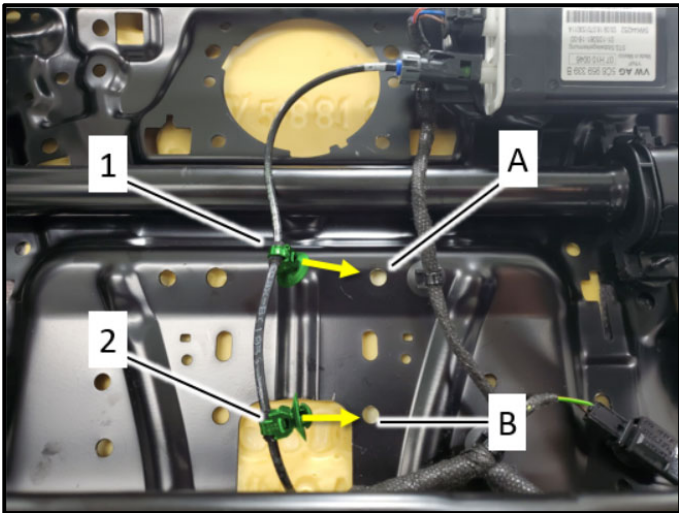

Secure PODS sensor mat harness (versions without storage compartment):

- Install clip <1> into hole <A>.
- Install clip <2> into hole .

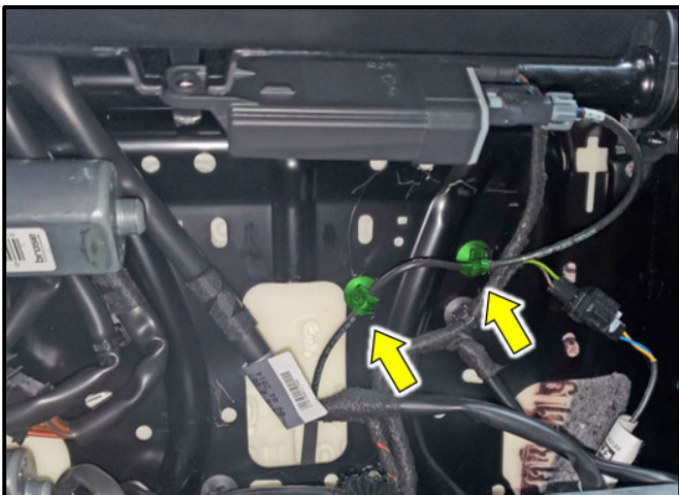

Secure PODS sensor mat harness (versions with storage compartment):

- Install wiring harness clips into seat pan as shown <arrows>.

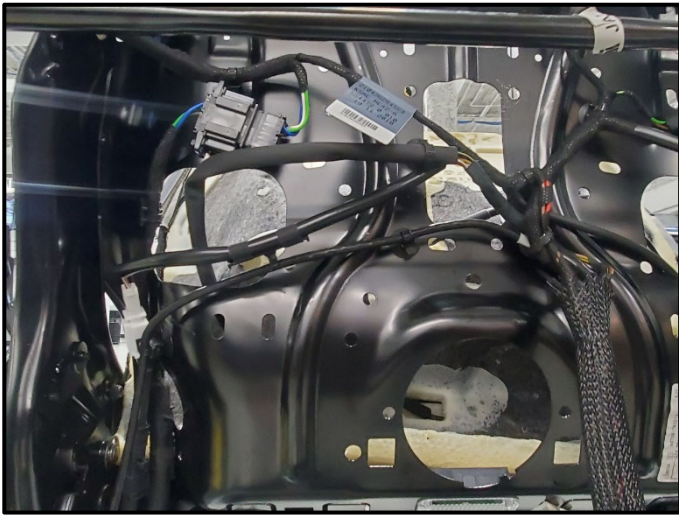

Resecure seat wiring harness:

- Connect and secure seat wiring harness in reverse order of removal.

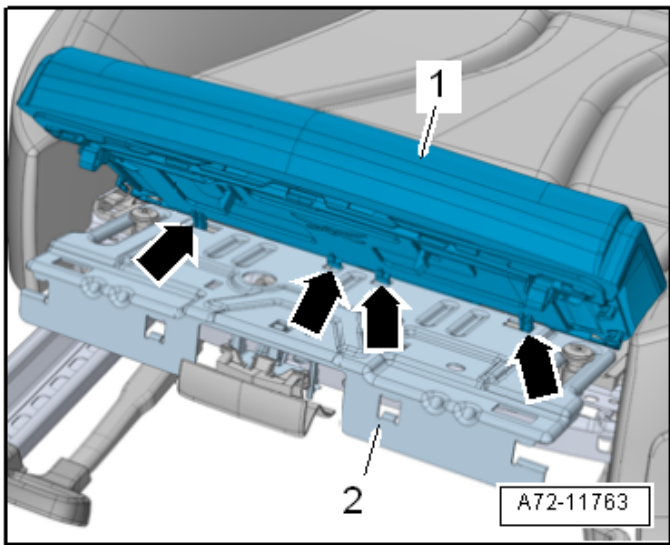

Reinstall seat depth adjuster (if equipped):

- Installation is the reverse order of removal.

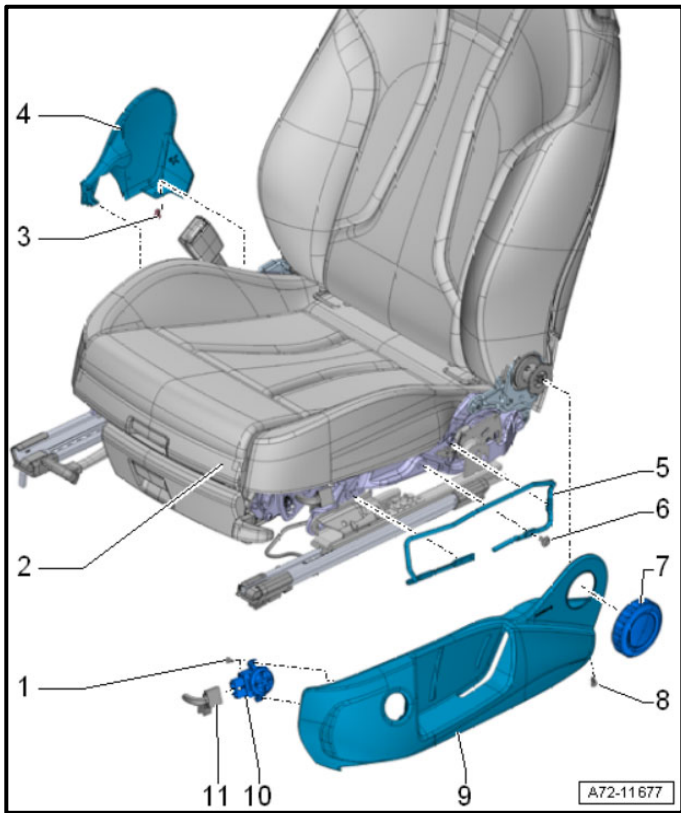

Reassemble seat trim and adjustment components:

- Installation is the reverse order of removal.
- Connect and secure seat adjustment electrical connectors.
- Torque fasteners for seat trim bracket to 7.5 Nm.

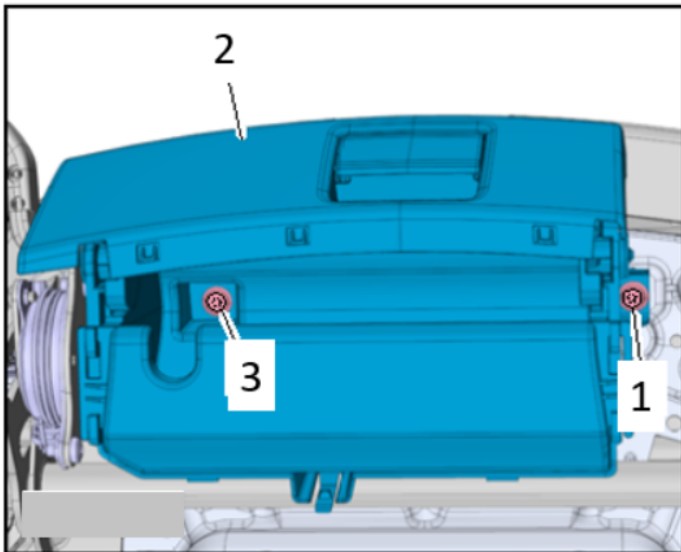

Reinstall storage compartment (if equipped):

- Installation is the reverse order of removal.
- Torque bolts <1 and 3> to 7.5 Nm.
- Clip PODS ECU onto compartment in the reverse order of removal.

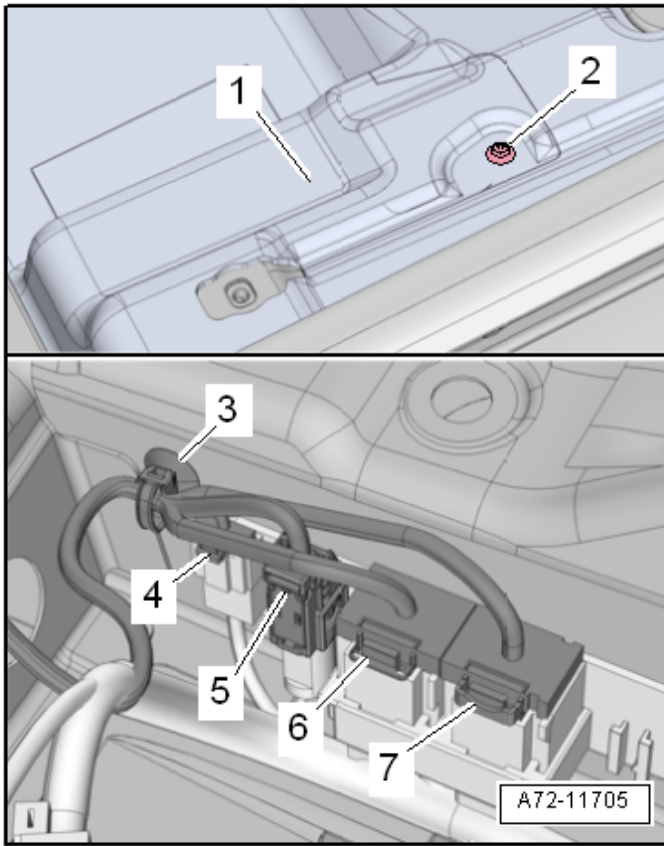

Reinstall seat:

- Place seat inside vehicle.

⚠ WARNING

Before handling pyrotechnic components (for example, connecting the connector), the person handling it must “discharge static electricity”. This can be done by touching the door striker, for example.

⚠ CAUTION

The ignition must be switched off before connecting airbag connector <5>.

- Disconnect the -VAS6282- from the thorax airbag harness connector.
- Reconnect the connectors in the specified order:
 - 4 - Seat Belt Latch
 - 5 - Thorax Airbag
 - 6 - If equipped with seat heater
 - 7 - Power Supply
- Reinstall expanding rivet <3>.

! NOTE

The number of connectors present in the connector station will vary based on vehicle equipment.

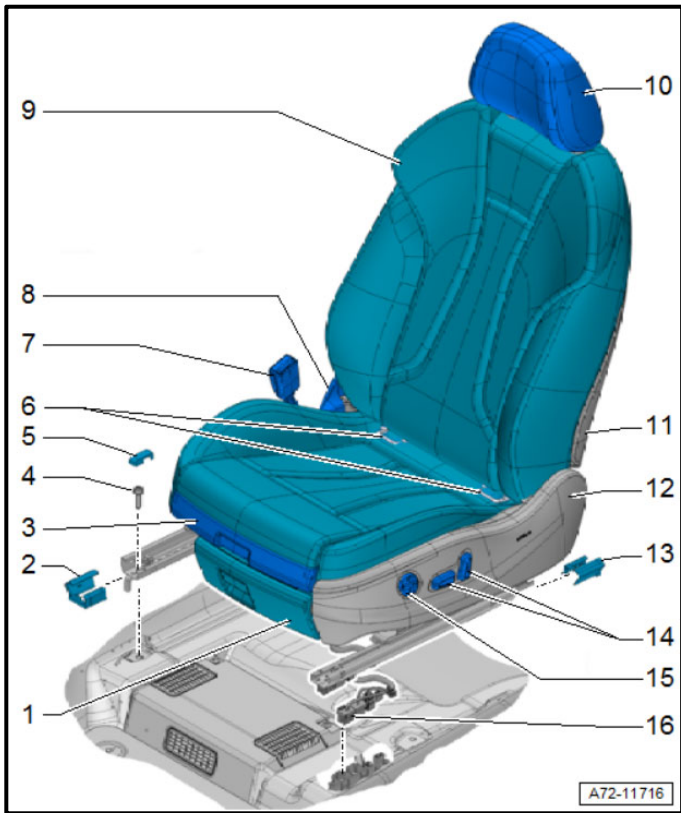

- Reinstall seat rail end covers in the reverse order of removal.
- Torque seat bolts to 40 Nm.

Proceed to Section C

Section C – PODS Control Module Calibration



⚠ CAUTION

- Never reprogram a PODS ECU before the PODS repair kit has been replaced.
 - Never swap a PODS ECU to or from another car for any reason.
- The PODS ECU will be updated using the PODS Programmer.
 - The Programmer stores data and its return to Audi may be required after it is no longer required to perform the repair in the 69BY Safety Recall.
 - A future communication will occur if the tool is expected to be returned.
 - See Appendix A for Programmer troubleshooting.
 - Install battery maintainer.

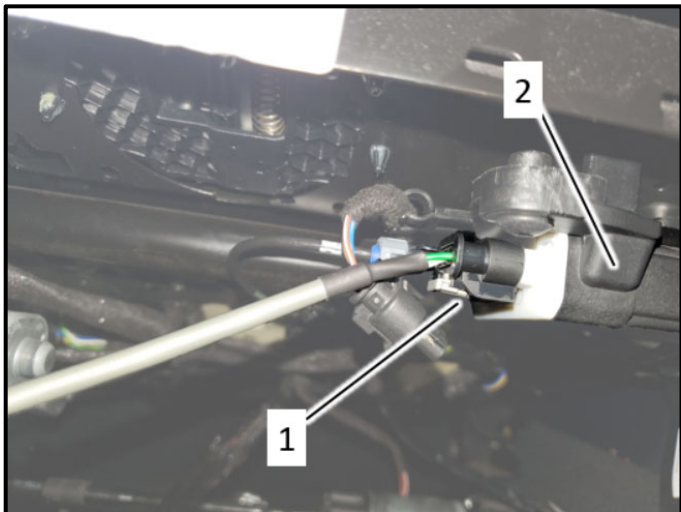

⚠ CAUTION

Battery voltage must be above 12.5 volts to ensure successful programming.

- Connect Programmer connector <1> to PODS ECU <2>.
- Plug in 12V outlet <1>.

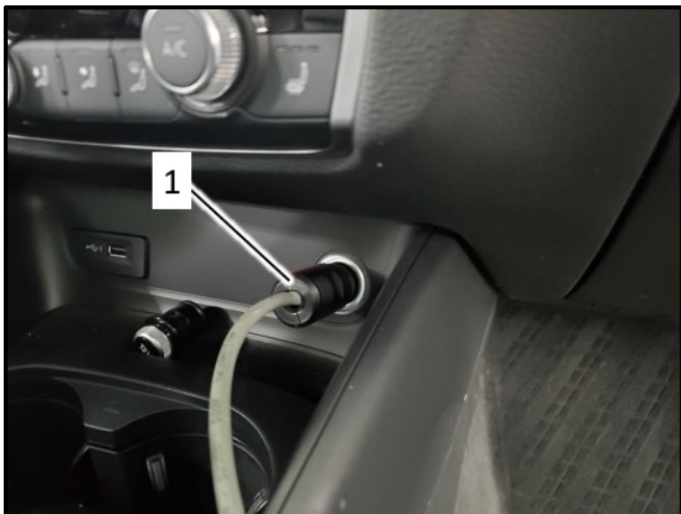



- Route the 12V power cable so that it does not rest on the passenger seat.

⚠ CAUTION

The Programmer cables must not rest on the seat.

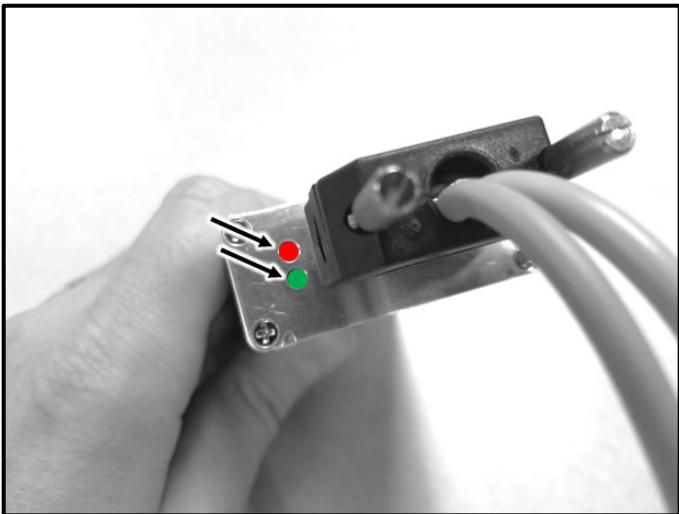

- Turn ignition on.
- Both lights <arrows> will illuminate simultaneously.
- If the lights are flashing simultaneously, see Appendix A for Programmer troubleshooting.

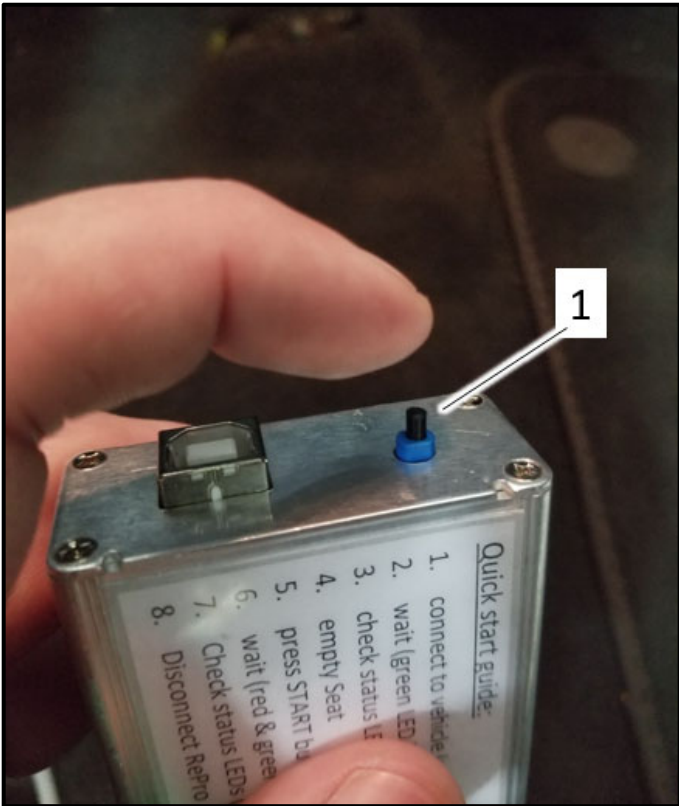

- Press button <1>.

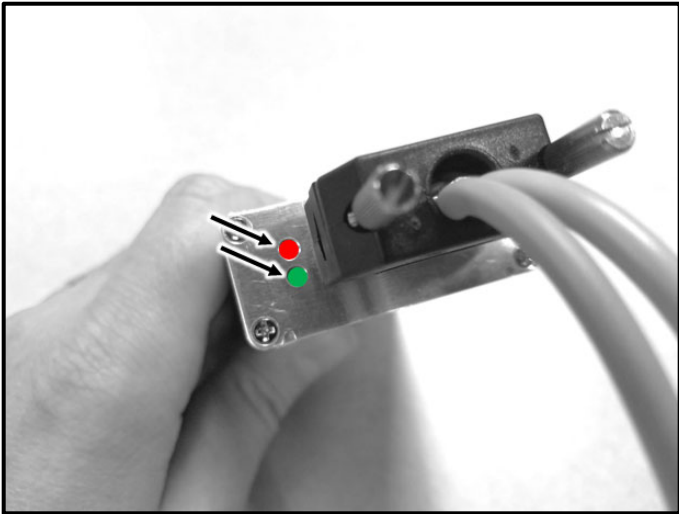

- Lights <arrows> will flash alternately.

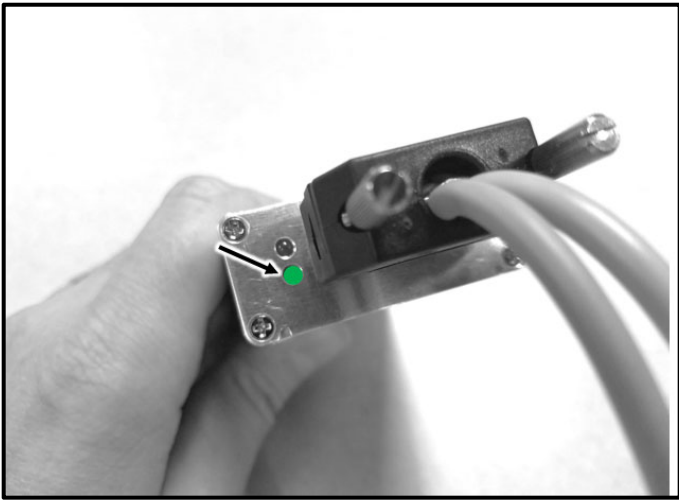

- A green flashing light <arrow> indicates successful programming. This will take about three minutes.
- Turn ignition off.
- Disconnect 12V outlet connection.
- Disconnect Programmer from PODS connector.
- Connect PODS wiring harness connector to PODS ECU.

⚠ CAUTION

If the programming fails, the issue must be resolved before returning the car to the customer.

Proceed to Section D

Section D – PODS Basic Settings

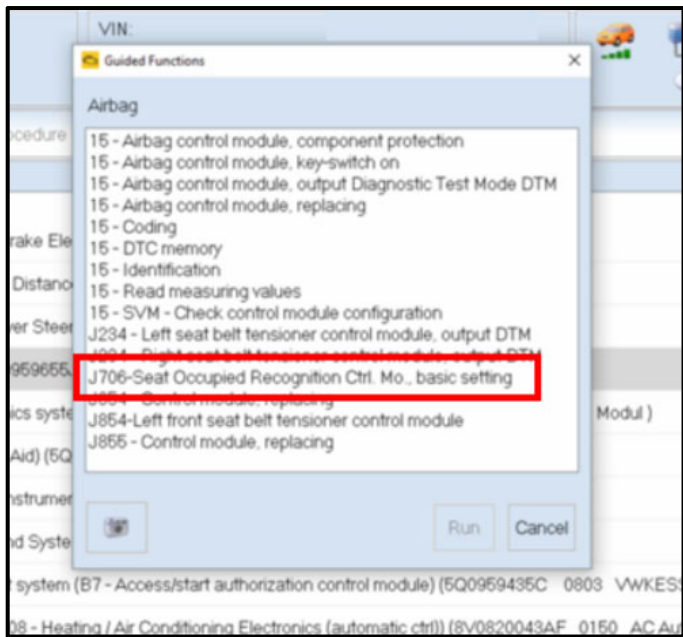

- Switch the ignition ON.
- Connect the VAS tester to the vehicle.
- Using ODIS, perform a complete GFF scan of the vehicle.
- Select the Guided Functions menu for 0015 - Airbag Control Module.
- Perform the test plan “*J706 – Seat Occupied Recognition Ctrl. Mo., basic setting*”.
- Follow the on screen prompts.
- Exit GFF.

Proceed to Section E

Section E – Campaign Completion Stamp

I certify that this campaign
has been performed in strict
accordance with the applicable
Audi repair procedure.

SAGA Code: _____
Technician: _____
Date: _____

Item#: AUD4927ENG

-OR-

Je certifie que cette
campagne de rappel a été
exécutée suivant les strictes
directives de réparation
d'Audi

Code de SAGA: _____
Technicien: _____
Date: _____

Item # AUD4927FRE

- Once the campaign has been completed, the technician should stamp the repair order.
- Stamps are available for ordering through the Compliance Label Ordering Portal.
- **Proceed to Section F**

Section F - Parts Return/Disposal

Properly store (retain), destroy or dispose of removed parts in accordance with all state/province and local requirements, unless otherwise indicated and/or requested through the Warranty Parts Portal (WPP) for U.S. and the Part Destruction and Core Disposition Report for Canada.

Appendix A – PODS Programmer Troubleshooting

CAUTION

- If the programming fails, the issue must be resolved before returning the car to the customer.
- Never swap a PODS ECU to or from another car for any reason.

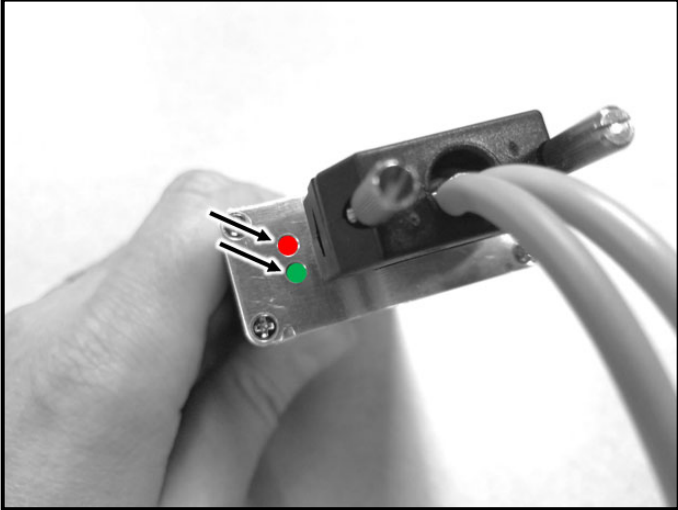

- If the start-up procedure fails, the red and green lights will flash simultaneously.
- This means the maximum number of stored records has been reached.
- If this situation is encountered, contact Audi Technical Assistance for further direction.

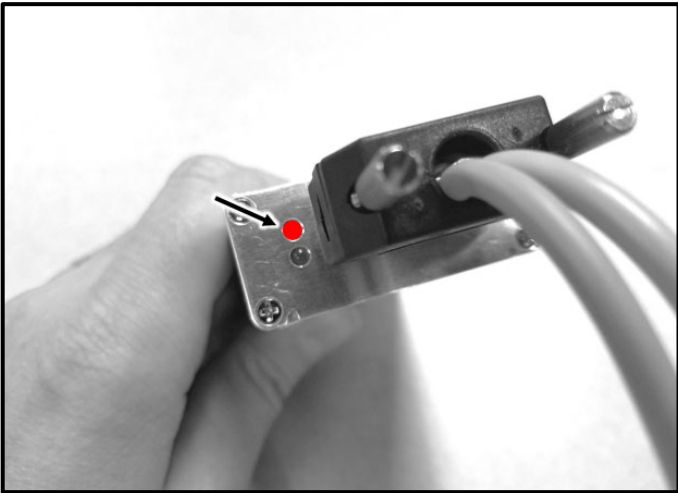

- If the programming has failed the red light will flash and one of the following may have occurred:
 - Red light flashes 2 times:
 - Battery voltage is too low.
 - Programmer not connected to PODS seat harness.
 - Red light flashes 3 times:
 - Wrong PODS kit was installed.
 - Red light flashes 4 times:
 - Seat was not empty.
 - Sensor not connected to the ECU.
- Once a problem is corrected, repeat the programming.
- If the above issues are all addressed and the programming still fails, contact Audi Technical Assistance for further direction and attach the following to the ATA case:
 - Photo of the Programmer lights.
 - Photo showing the battery voltage is above 12.5 volts.
 - Photo showing an EMPTY seat fully installed.

- Photo showing the PODS sensor wiring fully connected to the PODS ECU.
- Photo showing the Programmer fully connected to the seat harness.
- Photo of the part number of the PODS kit (from the package the part came in).