

RECALL: THIS MODIFICATION HAS TOP PRIORITY AND MUST BE PERFORMED IMMEDIATELY TO ENSURE CUSTOMER SAFETY

INSPECTION AND REPAIR OF THE MAIN WIRING HARNESS AND MODIFICATION OF THE TAIL END LOWER PART

**AFFECTED MODEL:
2020 1290 SUPER DUKE R**

**RESTRICTIONS: AFFECTED MODELS ARE LINKED BY VIN IN KTM
DEALER.NET**

INITIAL INFORMATION:

KTM North America, Inc. has determined that a defect which relates to motor vehicle safety exists with certain 2020 1290 SUPER DUKE R motorcycles pertaining to a possibility of damage to the wiring harness in the area of the tail end lower part on the lower subframe due to differences in the assembly process and an incorrect routing of the wiring harness. The main wiring harness must therefore be checked in three places for possible damage. Also the tail end lower part must be removed and modified to do this repair. On affected motorcycles there is a possibility of a short circuit if the wiring is damaged. If damage to the wiring harness exists, during operation it is possible that the engine can stop running if the wiring is damaged. If a short circuit happens there is a possibility it could lead to injury and/or damage to property.

To ensure the highest level of safety, performance, reliability and customer satisfaction, it is necessary to have the wiring harness located in the rear part of the motorcycle inspected for damage and repaired as necessary. A piece of the body work called the "tail end lower part" must also be modified by cutting out a section of it to improve the wiring routing. During the repair it will also be necessary to add two new additional pieces of wiring protection and cable ties to prevent damage to the wiring.

It is necessary to inspect and rework the wiring harness and perform one of the three following possible wiring repairs in addition to the tail end lower part modification which must be performed on every affected motorcycle.

1. **Wiring repair possibility #1:** If there is no damage or mild damage (Fig. 4) to the wiring insulation tape as explained on page 9 then you must perform the steps shown on page 9. Use the Action code ending in 00 when submitting the claim.
2. **Wiring repair possibility #2:** If there is damage to the wiring for the voltage regulator (Fig. 5.) which is located in **Area A** (Fig. 2) then the wire can be replaced. If the voltage regulator wire is damaged and needs replaced you will need to follow the instructions on page 10 and Annex 2 from the repair manual which is attached to the Dealer.net notification. Use the Action code ending in 01 when submitting the claim.
3. **Wiring repair possibility #3:** If the wiring insulation on the main wiring harness is damaged in **Area B and/or Area C** (Fig. 2, 3 & 6) then you must replace the main wiring harness and perform the steps shown on page 11. Use the Action code ending in 02 when submitting the claim.

COPYRIGHT NOTICE: The user acknowledges that all components of this technical information are KTM's and/or third parties' copyright protected property. Alteration, assignment, distribution and reproduction are forbidden.

LIMITATION OF LIABILITY: The information included in or available through this technical information may include inaccuracies or errors. In no event shall KTM and/or its suppliers be liable for any damages whatsoever, arising out of or in connection with the use of this technical information. Please always refer to the KTM owners and repair manuals for proper instructions or contact the KTM Dealer Services Department.

KTM NORTH AMERICA, INC.

38429 Innovation Court // Murrieta, CA 92563
1119 Milan Avenue // Amherst, OH 44001
8701 Rue Samuel-Hatt // Chambly, QC J3L-6V4
www.ktm.com



KTM is notifying all registered owners of affected motorcycles by mail. A copy of the customer letter is included in this bulletin. The customer should take the letter along with the affected motorcycle to an authorized KTM Dealer to have their wiring harness inspected and tail end lower part modified.

This recall must only be performed by trained technicians with proper equipment. Dealers are not to send out parts to customers and should take every reasonable action to make sure the customer does not try to repair or perform the recall on their vehicle. Doing so is a violation of Federal law. Dealers are to properly record the repair of the recall, report and return parts to KTM.

Dealers must inspect and repair the wiring harness and modify the tail end lower part on all affected motorcycles in their inventory prior to any customer delivery. Any affected 2020 1290 SUPER DUKE R models received directly from KTM North America, Inc. require the repair to be performed prior to customer delivery. Affected units acquired through dealer transfers or trades must be remedied and checked in KTM Dealer.net to ensure and document that the repair has been performed.

Motorcycles that are affected must not be sold or operated until the repair has been performed as described in this bulletin. It is a violation of KTM North America, Inc. policy for an authorized KTM Dealer to deliver any affected units to customers before the procedure in this bulletin has been performed.

KTM must report to the federal government on a regular basis how many units have been inspected and repaired during this campaign. Be sure to submit your warranty request for reimbursement on every unit repaired to ensure accurate compliance numbers.

COPYRIGHT NOTICE: The user acknowledges that all components of this technical information are KTM's and/or third parties' copyright protected property. Alteration, assignment, distribution and reproduction are forbidden.

LIMITATION OF LIABILITY: The information included in or available through this technical information may include inaccuracies or errors. In no event shall KTM and/or its suppliers be liable for any damages whatsoever, arising out of or in connection with the use of this technical information. Please always refer to the KTM owners and repair manuals for proper instructions or contact the KTM Dealer Services Department.

KTM NORTH AMERICA, INC.

38429 Innovation Court // Murrieta, CA 92563
1119 Milan Avenue // Amherst, OH 44001
8701 Rue Samuel-Hatt // Chambly, QC J3L-6V4
www.ktm.com



PROCEDURE FOR REPAIR:

On the following pages you will find the repair instructions for the three wiring repair possibilities.

Be aware that all three repair possibilities will require you to inspect the wiring of the motorcycle at the zoomed in locations shown below in Figure 1, 2 and 3.

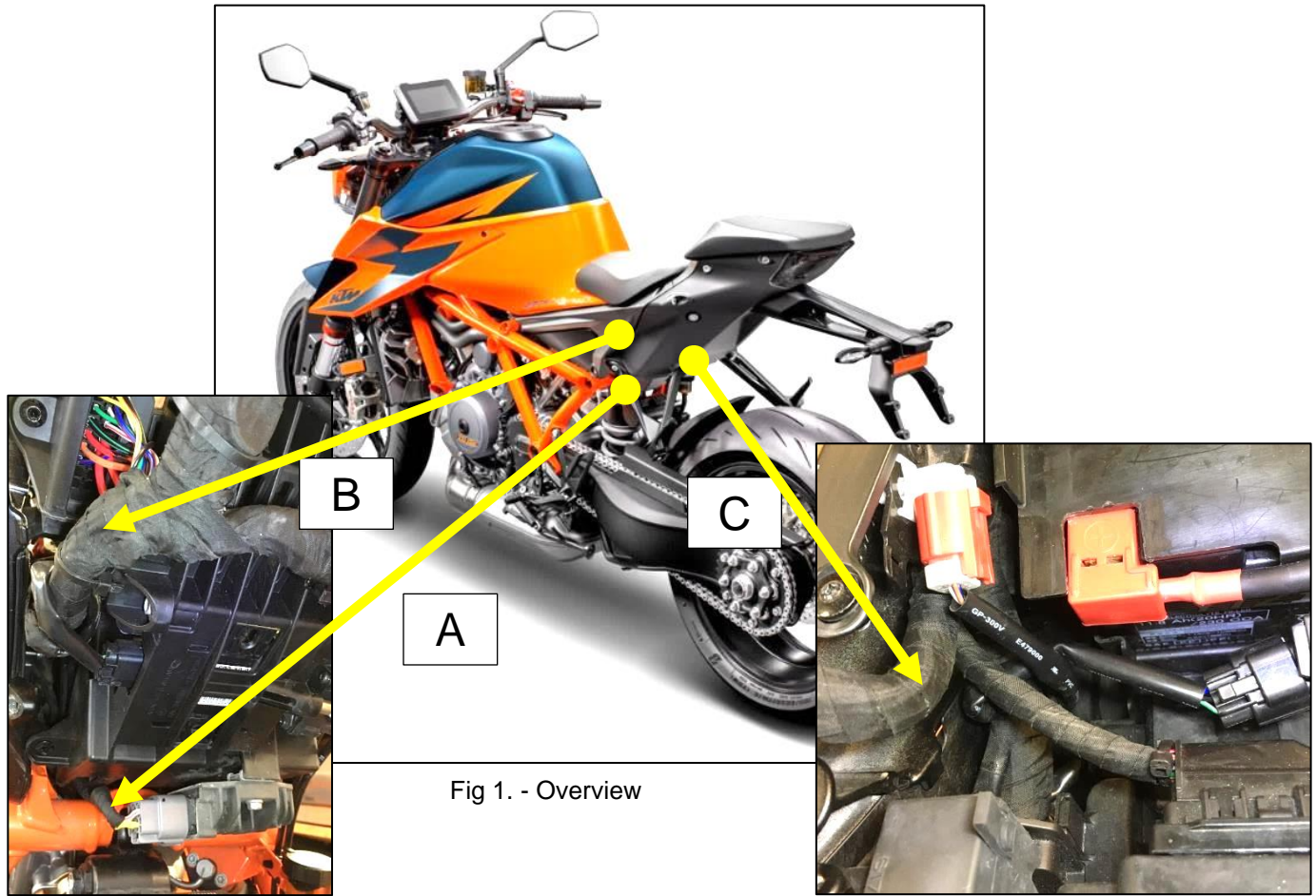

Fig 1. - Overview

Fig 2. - Zoom of Area A and B

Fig 3. - Zoom of Area C

Table 1 - Wiring locations to inspect and repair. Decide what action to take depending on the wires condition.

Area	Description	Possible action codes	
		Wire OK	Wire Not OK
A	Wiring harness from main wiring harness to voltage regulator	00	01/02
B	Main wiring harness in the diagnostics connector area	00	02
C	Main wiring harness in the seat lock area	00	02

COPYRIGHT NOTICE: The user acknowledges that all components of this technical information are KTM's and/or third parties' copyright protected property. Alteration, assignment, distribution and reproduction are forbidden.

LIMITATION OF LIABILITY: The information included in or available through this technical information may include inaccuracies or errors. In no event shall KTM and/or its suppliers be liable for any damages whatsoever, arising out of or in connection with the use of this technical information. Please always refer to the KTM owners and repair manuals for proper instructions or contact the KTM Dealer Services Department.

KTM NORTH AMERICA, INC.

38429 Innovation Court // Murrieta, CA 92563
 1119 Milan Avenue // Amherst, OH 44001
 8701 Rue Samuel-Hatt // Chambly, QC J3L-6V4
 www.ktm.com



Table 2 - Types of possible wiring damage. Perform the repair that relates to the condition of the wiring.

Action code	Damage pattern
00	<ul style="list-style-type: none"> - No wear or Mild wear to the black electrical insulation tape (Fig. 4). - No damage to the wire.
01	<ul style="list-style-type: none"> - Wire insulation from the voltage regulator ground down → copper visible (Fig. 5). - Damage less than 1 cm.
02	<ul style="list-style-type: none"> - Wire insulation melted, destroyed or cracked by more than 1 cm in any one area (Fig. 6). - Damage extends into the main wiring harness. - More than three wires damaged. <p style="text-align: center;">Repairs at level action code 02 must be approved by Dealer Services</p>



Fig. 4 - Mild or no Damage (follow code 00)



Fig. 5 - Copper visible (follow code 01)



Fig. 6 - Severe Damage (follow code 02)

COPYRIGHT NOTICE: The user acknowledges that all components of this technical information are KTM's and/or third parties' copyright protected property. Alteration, assignment, distribution and reproduction are forbidden.

LIMITATION OF LIABILITY: The information included in or available through this technical information may include inaccuracies or errors. In no event shall KTM and/or its suppliers be liable for any damages whatsoever, arising out of or in connection with the use of this technical information. Please always refer to the KTM owners and repair manuals for proper instructions or contact the KTM Dealer Services Department.

KTM NORTH AMERICA, INC.

38429 Innovation Court // Murrieta, CA 92563
 1119 Milan Avenue // Amherst, OH 44001
 8701 Rue Samuel-Hatt // Chambly, QC J3L-6V4
 www.ktm.com



Rear bodywork modification (tail end lower part)

(Please reference the repair manual for more detailed instructions on the removal and installation of parts)

All three wiring repair possibilities require the rear bodywork to be modified in conjunction with the wiring inspection and repair. Also all affected motorcycles must have the new cable protection and edge protection installed. It will also be necessary to secure the wiring harness in certain locations with additional cable ties (see Fig. 11 for cable tie securing and positioning).

Follow steps 1 through 9 below and Figures 7 through 9 for instructions on how to modify the rear bodywork.

Photos must be taken for documenting in the warranty claim.

1. Remove the tail end lower part as per the repair manual Annex 1.
Note: Annex 1 is an additional attachment that is available for download in the Dealer.net notification.
2. Check the main wiring harness for signs of rubbing, damaged or melted wires. See Figures 1 to 6 and Table 1 and Table 2 for further details.
3. Place the tail end lower part on a suitable underlay.
4. Mark bores and cut lines as shown in Fig. 7 → B = 15 mm C = 45 mm.
5. To avoid scratches, cover the surrounding area with adhesive tape.
6. Drill a hole at the marked point using a 10 mm drill bit. → A = 10 mm (Fig. 7).
7. Use a hand saw to saw laterally into the indicated section until it is completely cut out (Fig. 7 & 8).
8. Deburr and round off the edges of the cut section and remove the adhesive tape.
9. Place the plastic part (61708019025) on the rib of the inner side of the tail end lower part and mount the edge protection (76003095074) as shown (Fig. 9).

Table 3 – Torque specifications

Component	Screw	Torque	Remark
Screws, passenger foot peg bracket	M8	25 Nm	Medium strength thread lock (e.g. Loctite® 243™)
Screws, subframe metal flange	M8	25 Nm	Medium strength thread lock (e.g. Loctite® 243™)
Screws, subframe	M8	28 Nm	Medium strength thread lock (e.g. Loctite® 243™)
Screws, license plate holder	M6	10 Nm	
Screw, battery terminal	M6	4.5 Nm	

COPYRIGHT NOTICE: The user acknowledges that all components of this technical information are KTM's and/or third parties' copyright protected property. Alteration, assignment, distribution and reproduction are forbidden.

LIMITATION OF LIABILITY: The information included in or available through this technical information may include inaccuracies or errors. In no event shall KTM and/or its suppliers be liable for any damages whatsoever, arising out of or in connection with the use of this technical information. Please always refer to the KTM owners and repair manuals for proper instructions or contact the KTM Dealer Services Department.

KTM NORTH AMERICA, INC.

38429 Innovation Court // Murrieta, CA 92563
 1119 Milan Avenue // Amherst, OH 44001
 8701 Rue Samuel-Hatt // Chambly, QC J3L-6V4
 www.ktm.com



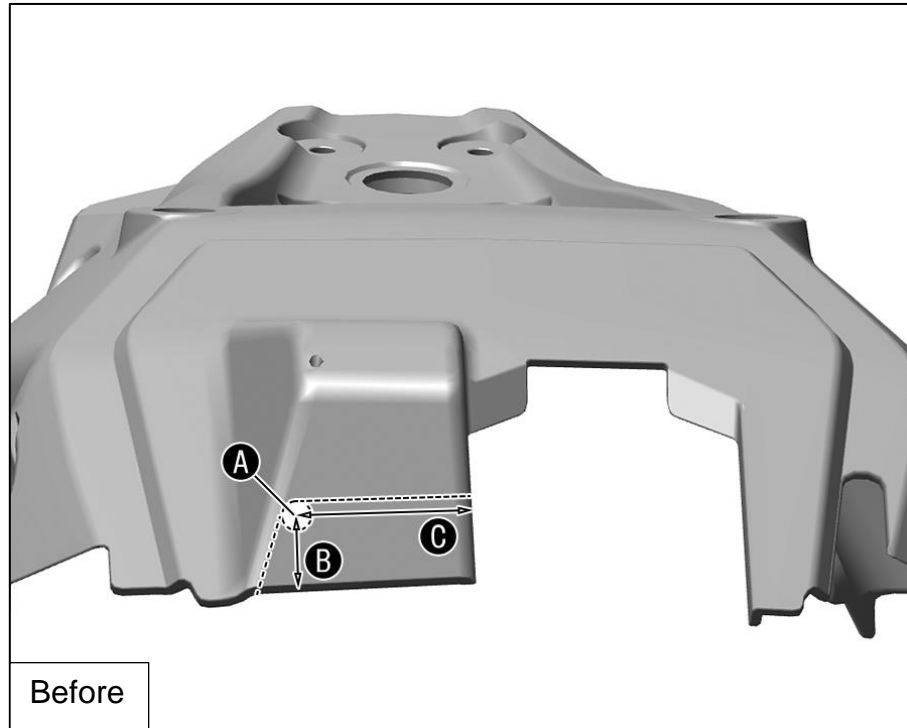

Fig. 7

As described in steps 4 through 8 on page 5 - Cut out the area shown in A, B and C
Bore position on the tail end lower part B = 15 mm C = 45 mm

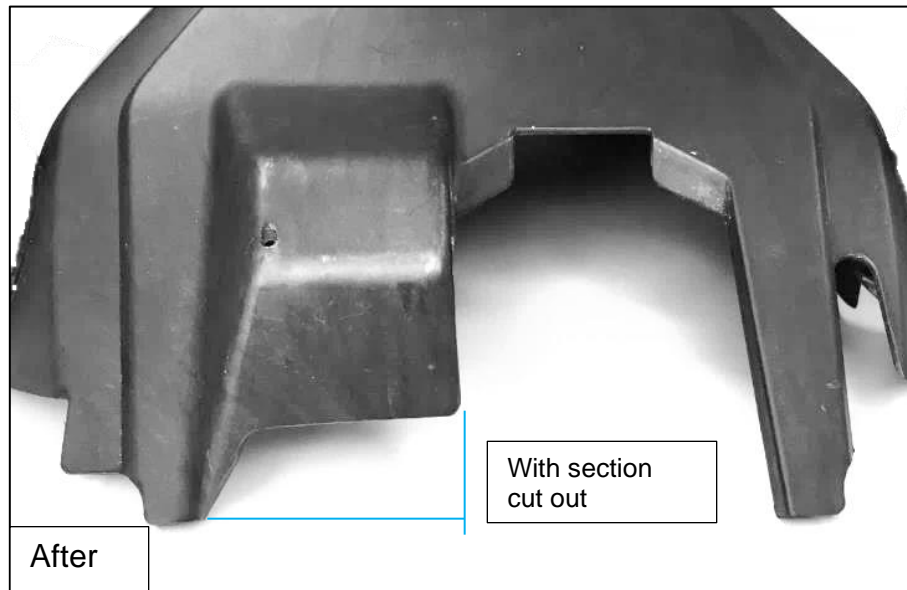

Fig. 8 - Piece of tail end lower part completely cut out

COPYRIGHT NOTICE: The user acknowledges that all components of this technical information are KTM's and/or third parties' copyright protected property. Alteration, assignment, distribution and reproduction are forbidden.

LIMITATION OF LIABILITY: The information included in or available through this technical information may include inaccuracies or errors. In no event shall KTM and/or its suppliers be liable for any damages whatsoever, arising out of or in connection with the use of this technical information. Please always refer to the KTM owners and repair manuals for proper instructions or contact the KTM Dealer Services Department.

KTM NORTH AMERICA, INC.

38429 Innovation Court // Murrieta, CA 92563
1119 Milan Avenue // Amherst, OH 44001
8701 Rue Samuel-Hatt // Chambly, QC J3L-6V4
www.ktm.com



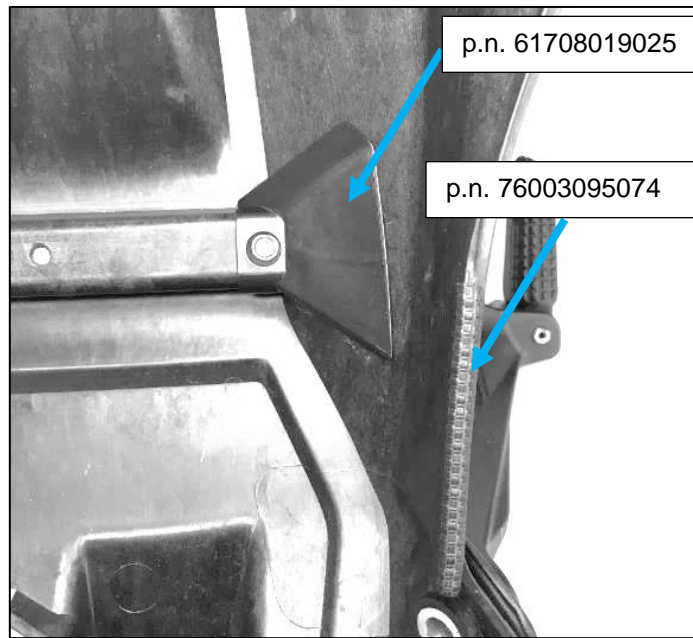

Fig. 9 - Mounting the inner wires and edge protection



Fig. 10 - Main wiring harness area to be checked

COPYRIGHT NOTICE: The user acknowledges that all components of this technical information are KTM's and/or third parties' copyright protected property. Alteration, assignment, distribution and reproduction are forbidden.

LIMITATION OF LIABILITY: The information included in or available through this technical information may include inaccuracies or errors. In no event shall KTM and/or its suppliers be liable for any damages whatsoever, arising out of or in connection with the use of this technical information. Please always refer to the KTM owners and repair manuals for proper instructions or contact the KTM Dealer Services Department.

KTM NORTH AMERICA, INC.

38429 Innovation Court // Murrieta, CA 92563
 1119 Milan Avenue // Amherst, OH 44001
 8701 Rue Samuel-Hatt // Chambly, QC J3L-6V4
 www.ktm.com





Fig. 11 - Securing the wiring harness with two cable ties

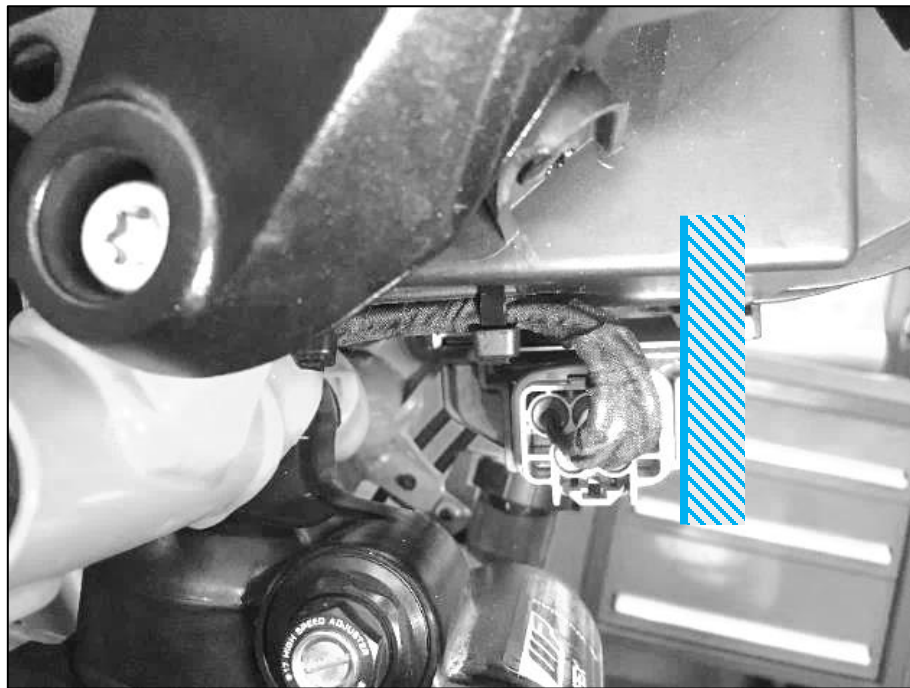

Fig. 12 - Wiring harness aligned correctly

COPYRIGHT NOTICE: The user acknowledges that all components of this technical information are KTM's and/or third parties' copyright protected property. Alteration, assignment, distribution and reproduction are forbidden.

LIMITATION OF LIABILITY: The information included in or available through this technical information may include inaccuracies or errors. In no event shall KTM and/or its suppliers be liable for any damages whatsoever, arising out of or in connection with the use of this technical information. Please always refer to the KTM owners and repair manuals for proper instructions or contact the KTM Dealer Services Department.

KTM NORTH AMERICA, INC.

38429 Innovation Court // Murrieta, CA 92563
1119 Milan Avenue // Amherst, OH 44001
8701 Rue Samuel-Hatt // Chambly, QC J3L-6V4
www.ktm.com



Wiring repair possibility #1 (No damage or mild damage – Action code 00)

(Please reference the repair manual for more detailed instructions on the removal and installation of parts)

Photos must be taken for documenting in the warranty claim.

1. Check the main wiring harness for signs of rubbing, damaged or melted wires in the locations Area A, B and C. See Figures 1 to 6 and Table 1 and Table 2 for further details.
2. If the wiring has no damage or mild damage as shown in Figure 4 repair the mildly worn insulation on the main wiring harness using black wiring harness insulation tape.
3. Also check the main wiring harness behind the side panel (Fig. 10 - page 7) for contact points and secure with cable ties if necessary.
4. As shown in Fig. 11 (Page 8), secure the wiring harness of the voltage regulator on the battery carrier, using two cable ties.

Note: The wiring harness of the voltage regulator must not protrude over the connector housing and the course to the main frame must be checked for contact points (Fig. 12 - Page 8).

5. Install the tail end lower part as per repair manual/Annex 1 and tighten screws as per Table 3.
6. Perform a visual check to ensure it is fitted correctly and perform a test ride.

Note:

It is assumed that only a small number of vehicles have damaged wires and only a small number of main wiring harnesses need to be replaced. Stockpiling parts for action codes 01 and 02 is therefore to be avoided as this can lead to bottlenecks in supplying parts.

COPYRIGHT NOTICE: The user acknowledges that all components of this technical information are KTM's and/or third parties' copyright protected property. Alteration, assignment, distribution and reproduction are forbidden.

LIMITATION OF LIABILITY: The information included in or available through this technical information may include inaccuracies or errors. In no event shall KTM and/or its suppliers be liable for any damages whatsoever, arising out of or in connection with the use of this technical information. Please always refer to the KTM owners and repair manuals for proper instructions or contact the KTM Dealer Services Department.

KTM NORTH AMERICA, INC.

38429 Innovation Court // Murrieta, CA 92563
 1119 Milan Avenue // Amherst, OH 44001
 8701 Rue Samuel-Hatt // Chambly, QC J3L-6V4
 www.ktm.com



Wiring repair possibility #2 (Damage to the voltage regulator wiring / visible copper – Action code 01)
(Please reference the repair manual for more detailed instructions on the removal and installation of parts)
 Photos must be taken for documenting in the warranty claim.

1. Check the main wiring harness for signs of rubbing, damaged or melted wires. See Figures 1 to 6 and Table 1 and Table 2 for further details.
2. **If the wiring has damage to the wire and has copper visible as shown in Figure 5 repair the wire as explained in the following steps.**
3. Disconnect the 12-V battery and remove the left cover on the rear frame.
4. Remove the connector housing as per Annex 2. Laterally guide the wiring harness out of the rear frame to ensure sufficient space for the subsequent wire repairs.
Note: Annex 2 is an additional attachment that is available for download in the Dealer.net notification.
5. Perform wire repairs as per Annex 2.
6. Guide the wiring harness to the voltage regulator again and mount the connector housing as per Annex 2.
7. As in Fig. 11 - Page 8, secure the wiring harness of the voltage regulator on the battery carrier, using two cable ties.
Note: The wiring harness must not protrude over the connector housing and the course to the main frame must be checked for contact points (Fig. 12 - Page 8).
8. Also check the main wiring harness behind the side panel (Fig. 10 - Page 7) for contact points and secure with cable ties if necessary.
9. Install the tail end lower part as per repair manual/Annex 1 and tighten screws as per Table 3.
10. Connect the 12-V battery and set the time and date in the dash.
11. Check the cable assignment on the voltage regulator again as per Table 4.
Note: If positive and negative connection points are mixed up, the battery will discharge.
12. Start the engine and check the charging voltage.
13. Read the fault memory using XC_2 and delete if necessary.
14. Perform a visual check to ensure it is fitted correctly and perform a test ride.

Table 4

Pin	Cable color	Cross section	Remark
1	Generator (yellow)	2.5 mm ²	Any Yellow wire
2	Generator (yellow)	2.5 mm ²	Any Yellow wire
3	Permanent positive (red-white)	2.5 mm ²	
4	Generator (yellow)	2.5 mm ²	Any Yellow wire
5	Ground (black)	2.5 mm ²	

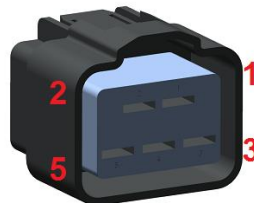

COPYRIGHT NOTICE: The user acknowledges that all components of this technical information are KTM's and/or third parties' copyright protected property. Alteration, assignment, distribution and reproduction are forbidden.

LIMITATION OF LIABILITY: The information included in or available through this technical information may include inaccuracies or errors. In no event shall KTM and/or its suppliers be liable for any damages whatsoever, arising out of or in connection with the use of this technical information. Please always refer to the KTM owners and repair manuals for proper instructions or contact the KTM Dealer Services Department.

KTM NORTH AMERICA, INC.

38429 Innovation Court // Murrieta, CA 92563
 1119 Milan Avenue // Amherst, OH 44001
 8701 Rue Samuel-Hatt // Chambly, QC J3L-6V4
 www.ktm.com



Wiring repair possibility #3 (Severe wire damage / main wiring harness replacement – Action code 02)
(Please reference the repair manual for more detailed instructions on the removal and installation of parts)

Photos must be taken for documenting in the warranty claim.

1. Check the main wiring harness for signs of rubbing, damaged or melted wires. See Figures 1 to 6 and Table 1 and Table 2 for further details.
2. **If the damage to the wiring is severe as shown in Figure 6 then the main wiring harness must be replaced.**
3. Disconnect the 12-V battery.
4. Replace the main wiring harness.
5. As in Fig. 11 - Page 8, secure the wiring harness of the voltage regulator on the battery carrier, using two cable ties.
Note: The wiring harness must not protrude over the connector housing and the course to the main frame must be checked for contact points (Fig. 12 - Page 8).
6. Install the tail end lower part as per repair manual.
7. Connect the 12-V battery, set the time and date.
8. Install the tail end lower part as per repair manual/Annex 1 and tighten screws as per Table 3.
9. Connect the battery and correct the time and date in the dash.
10. Read the fault memory using XC_2 and delete if necessary.
11. Perform a visual check to ensure it is fitted correctly and perform a test ride.

PARTS ORDERING:

The parts required to perform the repair depend on level of damage and the Action code that needs to be done. Refer to the Warranty Input form on page 12 for part numbers and quantity information for placing your parts order.

Note: It is assumed that only a small number of vehicles have damaged wires and only a small number of main wiring harnesses need to be replaced. Stockpiling parts for action codes 01 and 02 is therefore to be avoided as this can lead to bottlenecks in supplying parts.

VEHICLE LOCK INFORMATION:

Unsold motorcycles that are linked to this recall are locked in the vehicle history. The vehicle lock prevents the motorcycle from being retailed to a customer before the recall is performed. In order to unlock the vehicle you must perform the recall and then submit a TI claim. After the TI claim is submitted it will be possible to unlock and retail the motorcycle.

WARRANTY INPUT INFORMATION:

This Technical Bulletin only affects certain VIN numbers! Please check the VIN by performing a Motorcycle History search in KTM Dealer.net to determine if it's affected. If the motorcycle is affected, you will see a link to the bulletin and its repair status in the history results. KTM North America will not warranty units whose VIN numbers are not linked as this bulletin does not apply to them. It is the responsibility of the dealer to determine if the unit requires this update by checking the vehicle history and understanding the instructions provided by this bulletin.

Please note that when entering a warranty claim on an affected model, you must perform a vehicle history search, expand the **Technical information** window and click the orange arrow on the right side of the corresponding bulletin message.

You can now choose the TI Number from the list. The TI number for this procedure is according to the repairs performed and listed in the warranty claim input information; click **Continue with selected action code**.

The Warranty Claim is automatically entered for you, including parts & labor. You must enter additional information in the required fields marked with an asterisk "*" before submitting the claim to KTM. The flat rate time for this repair is based on the action performed and provided in minutes.

COPYRIGHT NOTICE: The user acknowledges that all components of this technical information are KTM's and/or third parties' copyright protected property. Alteration, assignment, distribution and reproduction are forbidden.

LIMITATION OF LIABILITY: The information included in or available through this technical information may include inaccuracies or errors. In no event shall KTM and/or its suppliers be liable for any damages whatsoever, arising out of or in connection with the use of this technical information. Please always refer to the KTM owners and repair manuals for proper instructions or contact the KTM Dealer Services Department.

KTM NORTH AMERICA, INC.

38429 Innovation Court // Murrieta, CA 92563
1119 Milan Avenue // Amherst, OH 44001
8701 Rue Samuel-Hatt // Chambly, QC J3L-6V4
www.ktm.com



Warranty type:
TI warranty
Component group:
08 - Mask, fender
Failure code:
900 – Failure identification by manufacturer
Failure causing component:
61708019000 – tail end lower part
Action code, parts, labor time:
<p>Rework of tail end lower part (wire OK)</p> <p>Action code: 08_1806661_00</p> <p>Labor time: 75 minutes</p> <p>Parts: 2 QTY. #44011076200 – cable tie 200/4.8 mm black 1 QTY. #61708019025 – cable protection, tail end lower part 1 QTY. #76003095074 – edge protection 9.5x6.5x74</p> <p>Tail end lower part rework + wire repairs</p> <p>Action code: 08_1806661_01</p> <p>Labor time: 95 minutes</p> <p>Parts: 2 QTY. # 44011076200 – cable tie 200/4.8 mm black 1 QTY. #61708019025 – cable protection, tail end lower part 1 QTY. #76003095074 – edge protection 9.5x6.5x74 1 QTY. #61711075010 – main wiring harness repair kit</p> <p>Rework of tail end lower part + replacement of main wiring harness</p> <p>Action code: 08_1806661_02</p> <p>Labor time: 240 minutes</p> <p>Parts: 1 QTY. #61711075133 – main wiring harness, complete. 1 QTY. #61708019025 – cable protection, tail end lower part 1 QTY. #76003095074 – edge protection 9.5x6.5x74 15 QTY. # 44011076140 – cable tie 140/2.5 mm black 15 QTY. # 44011076200 – cable tie 200/4.8 mm black</p>
Are stock items affected:
Yes

COPYRIGHT NOTICE: The user acknowledges that all components of this technical information are KTM's and/or third parties' copyright protected property. Alteration, assignment, distribution and reproduction are forbidden.

LIMITATION OF LIABILITY: The information included in or available through this technical information may include inaccuracies or errors. In no event shall KTM and/or its suppliers be liable for any damages whatsoever, arising out of or in connection with the use of this technical information. Please always refer to the KTM owners and repair manuals for proper instructions or contact the KTM Dealer Services Department.

KTM NORTH AMERICA, INC.

38429 Innovation Court // Murrieta, CA 92563
 1119 Milan Avenue // Amherst, OH 44001
 8701 Rue Samuel-Hatt // Chambly, QC J3L-6V4
 www.ktm.com



IMPORTANT SAFETY RECALL NOTICE
NHTSA Recall No. xxxxxx

Affected VIN: «Vin»
«PdiFirstName» «PdiLastName»
«PdiAddress1»
«PdiCity», «PdiProvince» «PdiPostalCode»

2/xx/2021

RE: Affected model: 2020 1290 Super Duke R

Dear KTM Customer,

This notice is sent to you in accordance with the requirements of the National Traffic and Motor Vehicle Safety Act. KTM North America, Inc. has determined that a defect which relates to motor vehicle safety exists in certain model year 2020 1290 Super Duke R motorcycles. To ensure the highest level of safety, performance, reliability and customer satisfaction, it is necessary to have the wiring harness located in the rear part of the motorcycle inspected for damage and repaired if necessary. The dealer must also modify a piece of the body work called the "tail end lower part" to correct the routing of the wiring harness and will also add wiring protection and cable ties to prevent damage to the wiring. This work must be performed by an authorized KTM Dealer and will be free of charge.

On affected motorcycles, there is a possibility of a short circuit if the wiring is damaged and during operation it is possible that the engine can stop running if the wiring is damaged. If a short circuit happens there is a possibility it could lead to injury and/or damage to property.

The cause of the defect is due to an incorrect routing of the wiring harness. To remedy this defect, the wiring harness located in the rear part of the motorcycle around the lower subframe must be inspected for damage and the "tail end lower part" must be modified by cutting out a section of it to improve the routing. Then two additional new pieces of wiring protection need to be added to the "tail end lower part" along with additional cable ties to further protect the wiring from damage.

Please contact your authorized KTM Dealer (log onto www.ktm.com for a complete dealer listing) as soon as possible to arrange having your wiring harness inspected and the "tail end lower part" modified with the new wiring protection added. It is suggested that you call your local authorized KTM Dealer to make an appointment to have the recall repair performed. The repair procedure will take between approximately 1.5 hours and 4 hours depending on how in depth the repair procedure is. It also may be necessary to leave your motorcycle with the dealer for a longer period of time depending on their work schedule and if they need to order additional replacement parts. Please present a copy of this letter along with your motorcycle to your local authorized KTM dealer. There will be no charge for this service.

If you have any questions related to the content of this letter, please contact KTM North America, Inc. Customer Relations at (888) 985-6090 for assistance. Furthermore, you may write the Administrator, National Highway Traffic Safety Administration, 1200 New Jersey Avenue, S.E., Washington, DC 20590 or call 1-888-327-4236 (TTY: 1-800-424-9153); or go to <http://www.safercar.gov>

If you have sold, traded or no longer own this motorcycle, it is important for the safety of the current owner that you inform KTM North America, Inc., of current ownership or unknown ownership status by returning the second page of this letter in the enclosed self-addressed prepaid postage envelope.

We apologize for any inconvenience and want to assure you that our commitment together with all KTM Dealers is to provide you with the highest level of service, support and customer satisfaction.

Best Regards,
Dealer Services Department
KTM North America, Inc.

COPYRIGHT NOTICE: The user acknowledges that all components of this technical information are KTM's and/or third parties' copyright protected property. Alteration, assignment, distribution and reproduction are forbidden.

LIMITATION OF LIABILITY: The information included in or available through this technical information may include inaccuracies or errors. In no event shall KTM and/or its suppliers be liable for any damages whatsoever, arising out of or in connection with the use of this technical information. Please always refer to the KTM owners and repair manuals for proper instructions or contact the KTM Dealer Services Department.

KTM NORTH AMERICA, INC.

38429 Innovation Court // Murrieta, CA 92563
1119 Milan Avenue // Amherst, OH 44001
8701 Rue Samuel-Hatt // Chambly, QC J3L-6V4
www.ktm.com

